

## Proposed 2012 North Carolina Amendments to the 2009 International Residential Code

(Changes only listed-all other 2009 IRC base code to remain)

### Residential Ad Hoc Committee Acknowledgements

David W. Conner, Sr, PE  
NC Department of Insurance  
1202 Mail Service Center  
Raleigh, NC 27699-1202

Leon Skinner  
City of Raleigh Inspections Department  
P.O. Box 590  
Raleigh, NC 27602

Jeff Griffin  
Mecklenburg County Government  
700 North Tryon Street  
Charlotte, NC 28202

David Smith, Committee Chair  
D. Smith, Builder  
905 Saltwood Lane  
Wilmington, NC 28411

Steve L. Knight, PE  
Structural Engineer  
1507 Mt. Vernon Ave  
Statesville, NC 28677

Dan Tingen, President  
Tingen Construction Company, Inc.  
8411-101 Garvey Drive  
Raleigh, NC 27616

Jim Lane  
City of Raleigh Inspections Department  
P.O. Box 590  
Raleigh, NC 27602

Hawley Truax  
Z. Smith Reynolds Foundation  
147 South Cherry St., #200  
Winston-Salem, NC 27101-5287

Mike Page  
NC Department of Insurance  
1202 Mail Service Center  
Raleigh, NC 27699-1202

Thomas P. Turner, FAIA Architect  
ADEP, PA  
3225 Wickersham Road  
Charlotte, NC 28211

Robert Privott  
NC Home Builders Association  
P.O. Box 99090  
Raleigh, NC 27624

Hiram Williams  
Action Construction Company  
P.O. Box 4270, 51 J.H. Batts Road  
Surf City, NC 28445

Add on page ix-Chapter 45 High Wind Zones. This chapter applies to buildings constructed in NC high wind zones. These provisions shall be in addition to or in lieu of the requirements of Chapters 1-8.

Add on page ix- Chapter 46 Coastal and Flood Plains Standards. The requirements of this Chapter apply to all construction located within areas identified by governmental agency (state and federal) as coastal high hazard area, ocean hazard areas, the regulatory flood plain areas, and all areas designated as 130mph (57 m/s) wind zone.

Add on page xx- Chapter 45 High Wind Zones.

Add on page xx- Chapter 46 Coastal and Flood Plains Standards.

Delete Xiii Sample ordinance page

# Chapter 1 Administration

Section	Change
<b>R101.1 Title</b>	These provisions shall be known as the <u>North Carolina Residential Code for One- and Two-Family Dwellings of [NAME OF JURISDICTION]</u> ; and shall be cited as such and will be referred to herein as is this code.
<b>R101.2 Scope</b>	<p>The provisions of the <u>International North Carolina Residential Code for One- and Two-Family Dwellings</u> shall apply to the construction, alteration, movement, enlargement, replacement, repair, equipment, use and occupancy, location, removal and demolition of detached one- and two-family dwellings and multiple single-family dwellings (townhouses) not more than three stories above grade in height with a separate means of egress and their accessory <u>buildings and</u> structures.</p> <p style="padding-left: 40px;"><b>Exception:</b> Live/work units complying with the requirements of Section 419 of the <u>NC Building Code</u> shall be permitted to be built as one- and two-family <i>dwellings</i> or Townhouses. Fire suppression required by Section 419.5 of the <u>NC Building Code</u> when constructed under the <u>NC Residential Code for One- and Two-family Dwellings</u> shall conform to Section 903.3.1.3 of the International Building Code.</p> <p><u>Accessory buildings with any dimension greater than 12 feet must meet the provisions of this code. Accessory buildings may be constructed without a masonry or concrete foundation, except in coastal high hazard or ocean hazard areas, provided all of the following conditions are met:</u></p> <ol style="list-style-type: none"> <li><u>1. The building shall not exceed 400 sq. ft. or one story in height:</u></li> <li><u>2. The building is supported on a wood foundation of a minimum 2x6 or 3x4 mud sill of approved wood in accordance with Section 323: and</u></li> <li><u>3. The building is anchored to resist overturning and sliding by installing a minimum of one ground anchor at each corner of the building. The total resisting force of the anchors shall be equal to 20 psf times the plan area of the building.</u></li> </ol> <p><u>Accessory structures are not required to meet the provisions of this code, except decks; gazebos; and retaining walls as required by Section R404.1.3. For swimming pools and spas, see Appendix G.</u></p>
<b>R101.3 Purpose</b>	The purpose of this code is to establish minimum requirements to safeguard the public safety, health and general welfare through affordability, structural strength, means of egress facilities, stability, sanitation, light and ventilation, energy conservation and safety to life and property from fire and other hazards attributed to the built environment.
<b>R102.5 Appendices</b>	Provisions in the appendices shall not apply unless specifically referenced in the <del>adopting ordinance</del> -Code text.
<b>R102.7 Existing Structures</b>	<del>For requirements of existing structures, refer to the North Carolina Administration and Enforcement Requirements Code. The legal occupancy of any structure existing on the date of adoption of this code shall be permitted to continue without change, except as is specifically covered in this code, the International Property Maintenance Code or the International Fire Code, or as is deemed necessary by the building official for the general safety and welfare of the occupants and the public.</del>
<b>R103.1-R103.3</b>	Delete and replace with: <u>Information concerning the creation and operation of inspections departments may be found in the North Carolina Administrative Code and Policies.</u>
<b>R104.1-R104.11.1</b>	Delete and replace with: <u>Information concerning the duties and powers of the building official may be found in the North Carolina Administrative Code and Policies.</u>

R105.1-R105.9	<p><b>Delete and replace with:</b>  <i>Information concerning permits may be found in the North Carolina Administrative Code and Policies.</i></p>
R106.1-R106.5	<p>Delete and replace with:  <i>Information concerning construction documents may be found in the North Carolina Administrative Code and Policies.</i></p>
<p>Section R107  Section R108  Section R109  Section R110  Section R111  Section R112  Section R113  Section R114</p>	<p><b>Delete all sections noted with no replacement language</b></p>
<h2>Chapter 2 Definitions</h2>	
R201.3 Terms defined in other codes	<p>Where terms are not defined in this code such terms shall have meanings ascribed to them as in other code publications of the <u>North Carolina</u> Code Council.</p>
Definitions	<p><b><u>ACCESSORY BUILDINGS.</u></b> <i>In one and two family dwellings not more than three stories high with separate means of egress, a building, the use of which is incidental to that of the main building and which is detached and located on the same lot.</i></p> <p><b><u>ACCESSORY STRUCTURE.</u></b> <i>Accessory structure is any structure not roofed over and enclosed that is not considered an accessory building located on one and two family dwelling sites which is incidental to that of the main building. Examples of accessory structures are but not limited to: fencing, decks, gazebos, arbors, retaining walls, barbecue pits, detached chimneys, tree houses, playground equipment, yard art, etc. Accessory structures are not required to meet the provisions of this code, except decks; gazebos; and retaining walls as required by Section R404.1.3.</i></p> <p>In one- and two-family dwellings not more than three stories high with separate means of egress, a building, the use of which is incidental to that of the main building and which is located on the same lot.</p> <p><b><u>ACCESSIBLE.</u></b> Signifies access that requires the removal of an access panel or similar removable obstruction. For energy purposes, ACCESSIBLE means admitting close approach as a result of not being guarded by locked doors, elevation or other effective means (see "Readily accessible").</p> <p><b><u>ACH50.</u></b> Air Changes per Hour of measured air flow in relation to the building volume while the building is maintained at a pressure difference of 50 Pascals.</p> <p><b><u>ADDITION.</u></b> An extension or increase in floor area or height of a building or structure. For energy purposes, an extension or increase in the <i>conditioned space</i> floor area or height of a building or structure.</p> <p><b><u>AIR BARRIER MATERIAL.</u></b> Material(s) that have an air permeability not to exceed 0.004 cfm/ft<sup>2</sup> under a pressure differential of 0.3 in. water (1.57psf) (0.02 L/s.m<sup>2</sup> @ 75 Pa) when tested in accordance with ASTM E 2178.</p> <p><b><u>AIR BARRIER SYSTEM.</u></b> Material(s) assembled and joined together to provide a barrier to air leakage through the building envelope. An air barrier is a combination of <i>air barrier materials</i> and sealants.</p> <p><b><u>APPROVED.</u></b> Acceptable to the building official.</p> <p><b><u>ATTIC, HABITABLE.</u></b> A finished <del>or unfinished</del> attic area meeting the definition of Habitable Space and <del>not considered a story</del>, complying with all of the following</p>

requirements:

1. The occupiable floor area is at least 70 square feet (17m<sup>2</sup>), in accordance with Section R304,
2. The occupiable floor area has a ceiling height in accordance with Section R305, and
3. The occupiable space is enclosed by the roof assembly above, knee walls (if applicable) on the sides and the floor-ceiling assembly below.

**BALCONY, EXTERIOR.** An exterior floor projecting from and supported by a structure without additional independent supports.

**BASEMENT WALL.** The opaque portion of a wall that encloses one side of a basement and has an average below grade wall area that is 50% or more of the total opaque and non-opaque area of that enclosing side. For energy purposes, a wall 50 percent or more below grade and enclosing conditioned space.

**BEDROOM.** Sleeping room.

**BPI ENVELOPE PROFESSIONAL.** An individual that has successfully passed the Building Performance Institute written and field examination requirements for the Building Envelope certification.

**BUILDING THERMAL ENVELOPE.** The basement walls, exterior walls, floor, roof, and any other building element that enclose conditioned space. This boundary also includes the boundary between conditioned space and any exempt or unconditioned space.

**CFM25.** Cubic Feet per Minute of measured air flow while the building is maintained at a pressure difference of 25 Pascal's (0.1 inches w.p.)

**CFM50.** Cubic Feet per Minute of measured air flow while the building is maintained at a pressure difference of 50 Pascal's (0.2 inches w.p.)

**CLOSED CRAWL SPACE.** A foundation without wall vents that uses air sealed walls, ground and foundation moisture control, and mechanical drying potential to control crawl space moisture. Insulation may be located at the floor level or at the exterior walls.

**CODE OFFICIAL.** The officer or other designated authority charged with the administration and enforcement of this code, or a duly authorized representative.

**CONDITIONED CRAWL SPACE.** A conditioned crawl space is a foundation without wall vents that encloses an intentionally heated and/or cooled space. Insulation is located at the exterior walls.

**CONDITIONED SPACE.** An area or room within a building being heated or cooled, containing uninsulated ducts, or with a fixed opening directly into an adjacent conditioned space.

**DAMP PROOFING.** A coating or the application of coatings applied to retard the penetration of water vapor and moisture through or into walls or into interior spaces.

**DECK.** An exterior floor system supported on at least two opposing sides by an adjoining structure and/or posts, piers, or other independent supports.

**EMERGENCY ESCAPE AND RESCUE OPENING.** An operable exterior window, door or similar device that provides for a means of escape and access for rescue in the event of an emergency.

**EXTERIOR WALL.** An above-grade wall that defines the exterior boundaries of a building. Includes between-floor spandrels, peripheral edges of floors, roof and basement knee walls, dormer walls, gable end walls, walls enclosing a mansard roof and basement walls with an average below-grade wall area that is less than 50 percent of the total opaque and nonopaque area of that enclosing side.

**F-FACTOR.** The perimeter heat loss factor for slab-on-grade floors (Btu/h x ft x °F) [W/(m x K)].

**FAMILY.** Family is an individual, two or more persons related by blood, marriage or law, or a group of not more than any five persons living together in a dwelling unit. Servants having common housekeeping facilities with a family consisting of an individual, or more persons related by blood, marriage or law, are a part of the family for this code.

**[B] FIREPLACE.** An assembly consisting of a hearth and fire chamber and smoke chamber, beginning at the hearth and ending at the top of the smoke chamber, of noncombustible material and provided with a chimney, for use with solid fuels.

**Factory-built fireplace.** A listed and labeled fireplace and chimney system composed of factory-made components, and assembled in the field in accordance with manufacturer's instructions and the conditions of the listing.

**Masonry chimney.** A field-constructed chimney composed of solid masonry units, bricks, stones or concrete, beginning at the top of the smoke chamber and the flue termination.

**Masonry fireplace.** A field-constructed fireplace composed of solid masonry units, bricks, stones or concrete, beginning at the hearth and ending at the top of the smoke chamber.

**Smoke chamber.** That part of a masonry fireplace which extends from the top of the firebox to the start of the chimney flue lining. A smoke chamber shall have a damper and a smoke shelf.

**FIRE SEPARATION DISTANCE.** The distance measured from the building face to one of the following:

1. To the closest interior lot line; or
2. To the centerline of a street, an alley or public way; or
3. To an imaginary line between two buildings on the lot.

The distance shall be measured at a right angle from the face of the wall.

**FOAM BACKER BOARD.** Foam plastic used in siding applications where the foam plastic is a component of the siding.

**FOAM PLASTIC INSULATION.** A plastic that is intentionally expanded by the use of a foaming agent to produce a reduced-density plastic containing voids consisting of open or closed cells distributed throughout the plastic for thermal insulating or acoustic purposes and that has a density less than 20 pounds per cubic foot (320 kg/m<sup>3</sup>) unless it is used as interior trim.

**FOAM PLASTIC INTERIOR TRIM.** Exposed foam plastic used as picture molds, chair rails, crown moldings, baseboards, handrails, ceiling beams, door trim and window trim and similar decorative or protective materials used in fixed applications.

**FULLY ENCLOSED ATTIC FLOOR SYSTEM**– The ceiling insulation is enclosed on all six sides by an air barrier system, such as taped drywall below, solid framing joists on the sides, solid blocking on the ends, and solid sheathing on top which totally enclose the insulation. This system provides for full depth insulation over the exterior walls.

**HAZARDOUS LOCATION, GLAZING.** See Section R308.4.

**HEAT TRAP.** An arrangement of piping and fittings, such as elbows, or a commercially available heat trap that prevents thermosyphoning of hot water during standby periods.

**HEATED SLAB.** Slab-on-grade construction in which the heating elements, hydronic tubing, or hot air distribution system is in contact with, or placed within or under, the slab.

**HEAT TRAP.** An arrangement of piping and fittings, such as elbows, or a commercially available heat trap that prevents thermosyphoning of hot water during standby periods.

**HEATED SLAB.** Slab-on-grade construction in which the heating elements, hydronic tubing, or hot air distribution system is in contact with, or placed within or under, the slab.

**HERS RATER.** An individual that has completed training and been certified by RESNET (Residential Energy Services Network) Accredited Rating Provider.

**HUMIDISTAT.** A regulatory device, actuated by changes in humidity, used for automatic control of relative humidity.

**HURRICANE-PRONE REGIONS.** Areas vulnerable to hurricanes, defined as the U.S. Atlantic Ocean and Gulf of Mexico coasts where the basic wind speed is greater than 90 or equal to 110 miles per hour (145 km/h), and Hawaii, Puerto Rico, Guam, Virgin Islands, and America Samoa.

**INFILTRATION.** The uncontrolled inward air leakage into a building caused by the pressure effects of wind or the effect of differences in the indoor and outdoor air density or both.

**LABELED.** Appliances, Equipment, materials or products to which have been affixed a *label*, seal, symbol or other identifying *mark* of a nationally recognized testing laboratory, inspection agency, or other organization as approved by the NC Building Code Council concerned with product evaluation that maintains periodic inspection of the production of the above-labeled items and whose labeling indicates either that the appliance, equipment, material or product meets identified standards or has been tested and found suitable for a specified purpose.

**MASONRY CHIMNEY.** Deleted.

**[B] MASONRY UNIT.** Brick, tile, stone, glass block or concrete block conforming to the requirements specified in Section 2103 of the North Carolina Building Code.

**Clay.** A building unit larger in size than a brick, composed of burned clay, shale, fire clay or mixtures thereof.

**Concrete.** A building unit or block larger in size than 12 inches by 4 inches by 4 inches (305 mm by 102 mm by 102 mm) made of cement and suitable aggregates.

**Glass.** Nonload-bearing masonry composed of glass units bonded by mortar.

**Hollow.** A masonry unit whose net cross-sectional area in any plane parallel to the loadbearing surface is less than 75 percent of its gross cross-sectional area measured in the same plane.

**Solid.** A masonry unit whose net cross-sectional area in every plane parallel to the loadbearing surface is 75 percent or more of its cross-sectional area measured in the same plane.

**PLANS.** Construction documents.

**[B] POSITIVE ROOF DRAINAGE.** Deleted.

**R-VALUE (THERMAL RESISTANCE).** The inverse of the time rate of heat flow through a body from one of its bounding surfaces to the other surface for a unit temperature difference between the two surfaces, under steady state conditions, per unit area ( $h \times \text{ft}^2 \times \text{°F/Btu}$ ) [ $\text{m}^2 \times \text{K/W}$ ].

**[B] REGISTERED DESIGN PROFESSIONAL.** See the NC Administration and Enforcement Requirements Code for definition.

**SCREW LAMP HOLDERS.** A lamp base that requires a screw-in-type lamp, such as a compact-fluorescent, incandescent, or tungsten-halogen bulb.

**SEMI-CONDITIONED SPACE** A space indirectly conditioned within the thermal envelope that is not directly heated or cooled. For energy purposes, semi-conditioned spaces are treated as conditioned spaces

**SERVICE WATER HEATING.** Supply of hot water for purposes other than comfort heating.

**SLEEPING ROOM.** A room designated as sleeping or bedroom on the plans.

**SOLAR HEAT GAIN COEFFICIENT (SHGC).** The ratio of the solar heat gain entering the space through the fenestration assembly to the incident solar radiation. Solar heat gain includes directly transmitted solar heat and absorbed solar radiation which is then reradiated, conducted or convected into the space. This value is related to the Shading Coefficient (SC) by the formula  $\text{SHGC} = 0.87 * \text{SC}$ .

**[B] STORY.** That portion of a building included between the upper surface of a floor and the upper surface of the floor or roof next above. A flood resistant enclosure, designed to break away so as not to cause collapse, shall not be considered as a story when determining height.

**STORY, ATTIC.** Any story situated wholly or partly in the roof, so designated, arranged or built as to be used for storage or habitation. If an attic which is accessible by a fixed stairway has a 7 ft. clear height for greater than 50% of the floor area of the story below, then the space shall be considered as a story.

**STRUCTURE.** Deleted.

**SUNROOM ADDITION.** A one-story structure attached added to an existing dwelling with a glazing area in excess of 40 percent of the gross area of the structure's exterior walls and roof.

**TOWNHOUSE.** A single-family dwelling unit constructed in a row of attached units separated by property lines and with open space on at least two sides.

**WALL, ABOVE-GRADE** A wall more than 50 percent above grade and enclosing *conditioned space*. This includes between-floor spandrels, peripheral edges of floors, roof and basement knee walls, dormer walls, gable end walls, walls enclosing a mansard roof and skylight shafts.

**WALL, CRAWLSPACE**. The opaque portion of a wall that encloses a crawl space and is partially or totally below grade.

**WALL VENTED CRAWL SPACE**. A foundation that uses foundation wall vents as a primary means to control space moisture. Insulation is located at the floor level.

**WATERPROOFING**. A coating or the application of coatings applied to prevent the penetration of water through or into walls or into interior spaces.

**WINDOW**. See Fenestration

**WIND BORNE DEBRIS REGION**. Areas within hurricane prone regions defined as that area east of the Intracoastal waterway from the NC/SC state line north to Beaufort Inlet and from that point to include the barrier islands to the NC/VA state line.

**ZONE**. A space or group of spaces within a building with heating or cooling requirements that are sufficiently similar so that desired conditions can be maintained throughout using a single controlling device.

## Chapter 3 Building Planning

### R301.2.1 Wind limitations

Buildings and portions thereof shall be limited by wind speed, as defined in Table R301.2(1) and construction methods in accordance with this code. Basic wind speeds shall be determined from Figure R301.2(4). Where different construction methods and structural materials are used for various portions of a building, the applicable requirements of this section for each portion shall apply. Where loads for ~~wall coverings~~, curtain walls, ~~roof coverings~~, exterior windows, skylights, garage doors and exterior doors are not otherwise specified, the loads listed in Table R301.2(2) adjusted for height and exposure using Table R301.2(3) shall be used to determine design load performance requirements for ~~wall coverings~~, curtain walls, ~~roof coverings~~, exterior windows, skylights, garage doors and exterior doors. ~~Asphalt shingles shall be designed for wind speeds in accordance with Section R905.2.6.~~

### R301.2.1.1 Design criteria

Construction in regions where the basic wind speeds from Figure R301.2(4) equal or exceed 110 miles per hour (49 m/s) shall be designed in accordance with one of the following:

1. American Forest and Paper Association (AF&PA) *Wood Frame Construction Manual for One- and Two-Family Dwellings (WFCM)*.
2. International Code Council (ICC) Standard for residential Construction in High Wind Regions (ICC-600).
3. Minimum Design Loads for Buildings and Other Structures (ASCE-7).
4. American Iron and Steel Institute (AISI), Standard for Cold-Formed Steel Framing Prescriptive Method for One- and Two-family Dwellings (*COFS/PM*) with *Supplement to Standard for Cold Formed Steel Framing—Prescriptive Method For One- and Two-Family Dwellings* (AISI S230).
5. Concrete construction shall be designed in accordance with the provisions of this code.
6. Structural insulated panel (SIP) walls shall be designed in accordance with the provisions of this code.
7. High wind chapters 45 and 46

**Table R301.2 (1)**

**Climatic and Geographic Design Criteria**

Roof Load	Wind Speed (mph)	Seismic Design Category	Subject to Damage From				Winter Design Temp	Ice Barrier Under-Layment Required	Flood Hazard <sup>b</sup>	Air Freezing Index	Mean Annual Temp
			Weathering <sup>a</sup>	Frost Line Depth	Termite <sup>c</sup>	Decay					
20	Figure 301.2(4)	301.2(2)	Moderate	12"	Moderate - Heavy	Moderate	Local	Local	Local	Local	Local

For SI: 1 pound per square foot = 0.0479 kN/m.<sup>2</sup>, 1 mile per hour = 1.609 km/h.

- a. Weathering may require a higher strength concrete or grade of masonry than necessary to satisfy the structural requirements of this code. The grade of masonry units shall be determined from ASTM C 34, C 55, C 62, C 73, C 90, C 129, C 145, C 216 or C 652.
- b. The Jurisdiction shall fill in this part of the table with (a) the date of the jurisdiction's entry into the National Flood Insurance Program (date of adoptions of the first code or ordinance for management of flood hazard areas), (b) the date(s) of the currently effective FIRM and FBFM, or other flood hazard map adopted by the community, as may be amended.
- c. Protection is required in all of NC per section R318.

**Figure R301.2(2)**

**Delete Figure R301.2 (2) on pages 27, 28, 29, 30, 31 and add NC Figure R301.2 (2) – remove word “continued” from NC Figure.**



SEISMIC DESIGN  
CATEGORY A

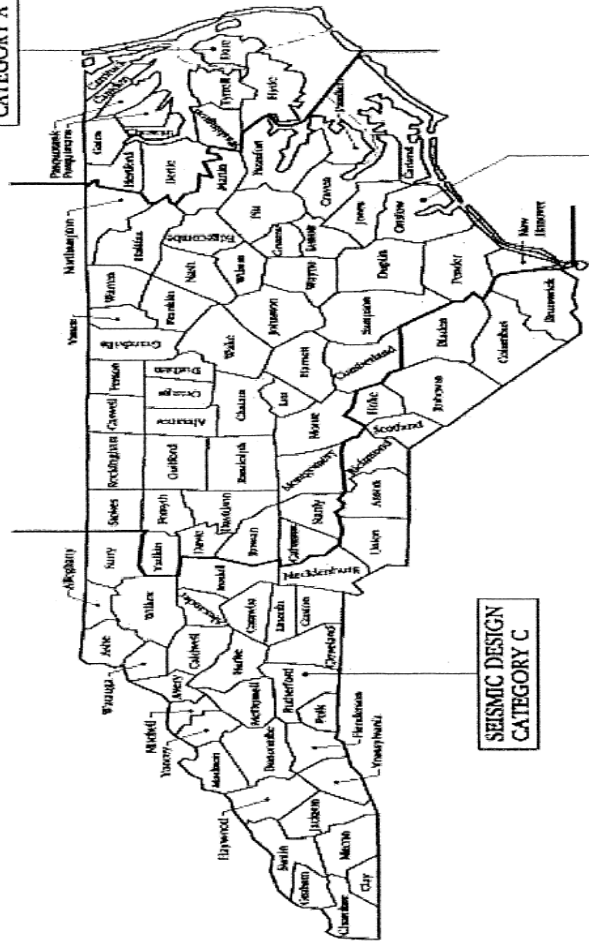

SEISMIC DESIGN  
CATEGORY B

SEISMIC DESIGN  
CATEGORY C

For SI: 1 foot = 304.8 mm.

- a. Seismic data is based upon FIGURE R301.2(2) - continued in the International Residential Code, as adjusted for North Carolina.
- b. The seismic provisions of this code shall apply to buildings constructed in Seismic Design Categories C in accordance with Section R301.2.2.

Exception: detached one- and two-family dwellings located in Seismic Design Category C are exempt from the seismic requirements of this code.

FIGURE R301.2(2) - continued  
 INTERNATIONAL RESIDENTIAL CODE - NORTH CAROLINA AMENDMENTS  
 SEISMIC DESIGN CATEGORIES - SITE CLASS D

(Need to make division lines darker)

COUNTIES IN SEISMIC DESIGN CATEGORY C

Alleghany  
Alexander  
Anson  
Ashe  
Avery  
Bladen  
Brunswick  
Buncombe  
Brunswick  
Burke  
Caldwell  
Catawba  
Cherokee  
Cleveland  
Columbus  
Gaston  
Graham  
Haywood  
Henderson  
Hoke  
Iredell  
Jackson  
Lincoln  
Macon  
Madison  
McDowell  
Mecklenburg  
Mitchell  
Polk  
Richmond  
Robeson  
Rutherford  
Scotland  
Surry  
Swain  
Transylvania  
Union  
Watauga  
Wilkes  
Yancey

FIGURE R301.2(2)-continued

Figure R301.2  
(3)  
  
Figure R301.2  
(4)

**Delete Figure R301.2 (3)**

Delete figure (pages 33,34,35,36,37)

<b>Table 301.2 (4)</b>	<b>Design Pressures For Doors and Windows a,b,c,d</b>			
	<b>Positive and Negative In PSF</b>			
	<b>Velocity (mph)</b>	<b>Mean Roof Height (ft)</b>		
		<b>15</b>	<b>25</b>	<b>35</b>
90	15	17	19	
100	20	23	25	
	<p>For SI: 1 foot = 304.8, 1 mile per hour = 0.44 m/s.</p> <p>a. Alternate design pressures may be determined by using North Carolina State Building Code – General Construction, ASCE-7, or the <u>2009</u> International Building Code.</p> <p>b. If window or door is more than 4 ft. from a corner, the pressure from this table shall be permitted to be multiplied by 0.87. This adjustment does not apply to garage doors.</p> <p>c. For windows and doors in structures with a roof slope of 10 degrees or less (2:12) from the table may be multiplied by 0.90.</p> <p>d. Design pressure ratings based on standards listed in Section 613 are adequate documentation of capacity to resist pressures from the table.</p>			
<b>Figure R301.2 (5)</b>	<b>Delete Figure R301.2(5) pg 38, 39</b>			
<b>R301.2.1.5 R301.2.1.5.1</b>	<b>Delete</b>			
<b>Table R301.2.1.5.1</b>	<b>Delete</b>			
<b>Figure R301.2.1.5(1)</b>	<b>Delete</b>			
<b>R301.2.1.5</b>	<b>Delete</b>			
<b>R301.2.1.5.1</b>	<b>Delete</b>			
<b>Table R301.2.1.5.1</b>	<b>Delete</b>			
<b>Figure R301.2.1.5.1 (1)</b>	<b>Delete</b>			
<b>Figure R301.2.1.5.1 (2)</b>	<b>Delete</b>			
<b>R301.2.1.5.1 (3)</b>	<b>Delete</b>			
<b>R301.2.2.1.1</b>	<b>Delete</b>			
<b>Table R301.2.2.1.1</b>	<b>Delete</b>			
<b>R301.2.1.1.2</b>	<b>Delete</b>			

<b>R301.2.2.2 Seismic Design Category C</b>	<b>R301.2.2.2 Seismic Design Category C.</b> <u>Townhouse</u> structures assigned to Seismic Design Category C shall conform to the requirements of this section.
<b>R301.2.2.2.4 Concrete Construction</b>	<b>R301.2.2.2.4 Concrete construction.</b> <del>Detached one and two family dwellings with exterior above grade concrete walls shall comply with the requirements of Section R611, PCA100 or shall be designed in accordance with ACI 318.</del> Townhouses with above grade exterior concrete walls shall comply with the requirements of PCA 100 or shall be designed in accordance with ACI 318.
<b>R301.2.2.3 R301.2.2.3.1 R301.2.2.3.2 R301.2.2.3.3 R301.2.2.3.4 R301.2.2.3.5 R301.2.2.3.6 R301.2.2.3.7 R301.2.2.4</b>	<b>Delete</b>
<b>R301.2.4 Floodplain construction</b>	Buildings and structures constructed in flood hazard areas (including A or V Zones) as established in Table R301.2(1) shall be designed and constructed in accordance with Section R323. <b>Exception:</b> <u>Buildings in floodways that are designated on the Flood Insurance Rate Maps (FIRM) or the Flood Boundary and Floodway Maps (FBFM) that are provided by the National Flood Insurance Program shall not be approved under this section; the provisions of the ASCE 24 shall apply.</u>
<b>Figure R301.2 (4)</b>	<b>Delete Figure R301.2 (4) pages 33,34,35,36,37 and replace with following NC Figure R301.2 (4) –remove word “continued” from NC figure. Change spelling on NC County “Harnet” to “Harnett” on County listing, also remove from footnote #4 the word Island behind Topsail.</b>

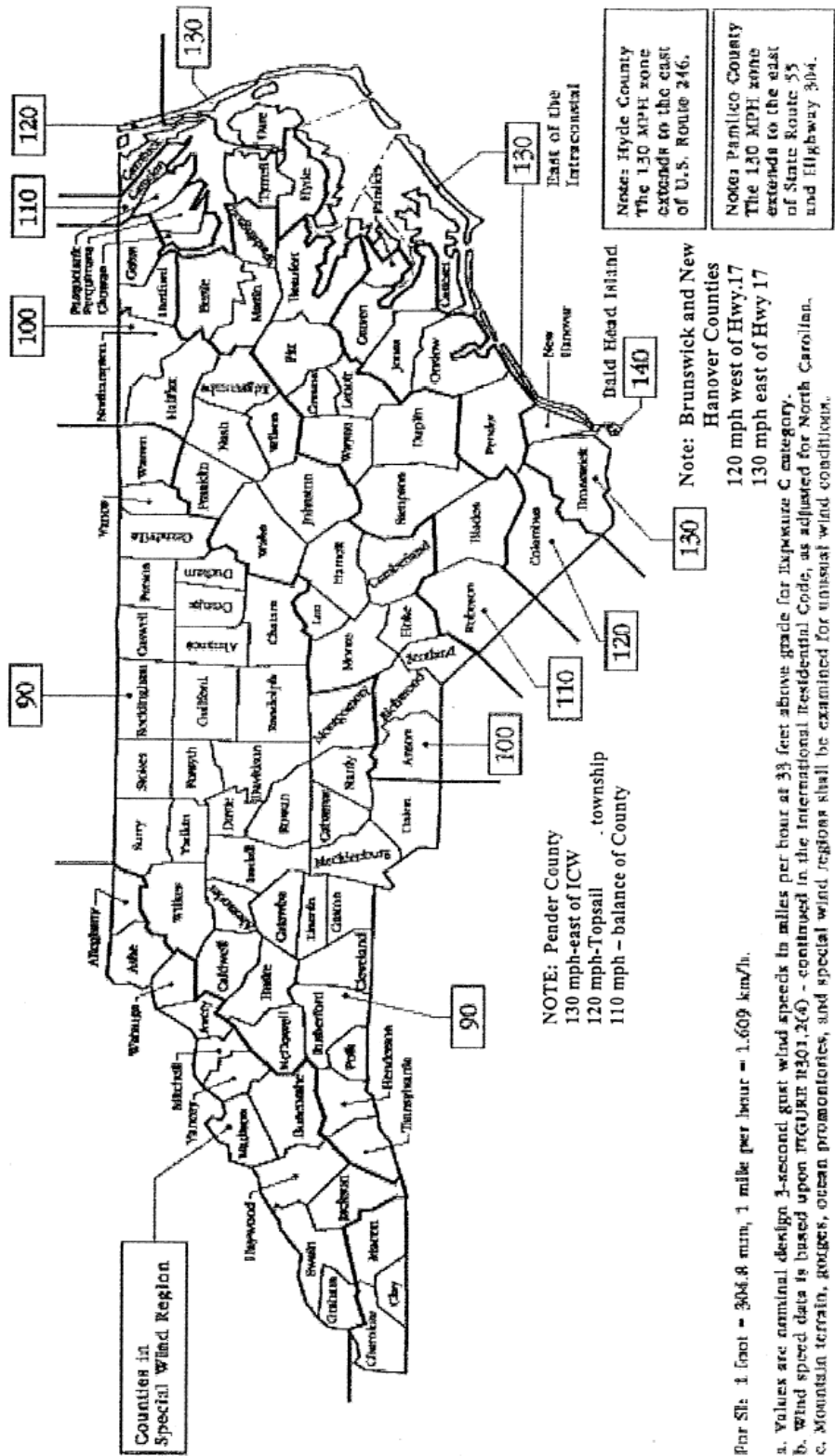

FIGURE R301.2(4) - continued  
INTERNATIONAL RESIDENTIAL CODE - NORTH CAROLINA AMENDMENTS  
BASIC WIND SPEEDS FOR 50-YEAR MEAN RECURRENCE INTERVAL

### BASIC DESIGN WIND SPEEDS

Counties not listed	90		
Anson	100	Lee	100
Alleghany	special mountain region	Lenior	110
Ashe	special moutain region	Madison	special mountain region
Avery	special mountain region	Martin	110
Beaufort	110	Mitchell	special mountain region
Bertie	110	Moore	100
Bladen	110	Nash	100
Brunswick <sup>1</sup>	120/130	New Hanover <sup>3</sup>	120/130
Buncombe	special mountain region	Northampton	100
Camden	110	Onslow	120/130 east of ICW
Carteret	130	Pamlico <sup>5</sup>	120/130
Chowan	110	Pasquotank	110
Columbus	120	Pender <sup>4</sup>	110/120/130
Craven	120	Perquimans	110
Cumberland	100	Pitt	110
Currituck	120	Richmond	100
Dare	130	Robeson	110
Duplin	110	Sampson	110
Edgecombe	100	Scotland	100
Franklin	100	Swain	special mountain region
Gates	100	Tyrell	120
Graham	special mountain region	Wake	100
Greene	110	Washington	110
Halifax	100	Watauga	special mountain region
Harnet	100	Wayne	110
Haywood	special mountain region	Wilson	100
Hertford	100	Yancey	special mountain region
Hoke	100		
Hyde <sup>2</sup>	120/130		
Jackson	special mountain region		
Johnston	100		
Jones	120		

**FIGURE R301.2(4)-continued**

1. Brunswick County - 120 mph zone west of Hwy 17, 130 mph zone east of Hwy 17, *140 mph on Bald Head Island.*
2. Hyde County - 120 mph zone west of US Route 246, 130 mph zone east of US Route 246.
3. New Hanover County - 120 mph zone west of Hwy 17, 130 mph zone east of Hwy 17.
4. Pender County - 130 mph zone east of the Intercoastal Waterway, 120 mph zone in the Township of Topsail Island, and the remainder of the County is the 110 mph zone.
5. Pamlico County - 130 mph zone east of SR 55 and Hwy 304, 120 mph zone west of SR 55 and Hwy 304.

**Figure R301.2  
(4)**

**FIGURE R301.2(4)—continued  
BASIC DESIGN WIND SPEEDS FOR 50-YEAR MEAN RECURRENCE INTERVAL**

Counties not listed	90		
Anson	100	Lee	100
Alleghany	special mountain region	Lenior	110
Ashe	special mountain region	Madison	special mountain region
Avery	special mountain region	Martin	110
Beaufort	110	Mitchell	special mountain region
Bertie	110	Moore	100
Bladen	110	Nash	100
Brunswick <sup>1</sup>	120/130	New Hanover <sup>3</sup>	120/130
Buncombe	special mountain region	Northampton	100
Camden	110	Onslow	120/130 east of ICW
Carteret	130	Pamlico <sup>5</sup>	120/130
Chowan	110	Pasquotank	110
Columbus	120	Pender <sup>4</sup>	110/120/130
Craven	120	Perquimans	110
Cumberland	100	Pitt	110
Currituck	120	Richmond	100
Dare	130	Robeson	110
Duplin	110	Sampson	110
Edgecombe	100	Scotland	100
Franklin	100	Swain	special mountain region
Gates	100	Tyrell	120
Graham	special mountain region	Wake	100
Greene	110	Washington	110
Halifax	100	Watauga	special mountain region
Harnett	100	Wayne	110
Haywood	special mountain region	Wilson	100
Hertford	100	Yancey	special mountain region
Hoke	100		
Hyde <sup>2</sup>	120/130		
Jackson	special mountain region		
Johnston	100		
Jones	120		

1. Brunswick County - 120 mph zone west of Hwy 17, 130 mph zone east of Hwy 17, 140 mph on Bald Head Island.

2. Hyde County - 120 mph zone west of U.S. Route 264, 130 mph zone east of U.S. Route 264.

3. New Hanover County - 120 mph zone west of Hwy 17, 130 mph zone east of Hwy 17.

4. Pender County - 130 mph zone east of the Intercoastal Waterway, 120 mph zone in the Township of Topsail, and the remainder of the County is the 110 mph zone.

5. Pamlico County - 130 mph zone east of SR 55 and Hwy 306, 120 mph zone west of SR 55 and Hwy 306.

Table 301.7	<p style="text-align: center;"><b>Table 301.7</b> <b>Allowable Deflection of Structural Members</b> a,b,c,d,e</p> <p>Change note under table to read: <b>Note:</b> L= span length in inches, H= span height in inches. f. <u>When floor spans exceed 20 feet, joists, built-up beams and trusses shall not be spaced greater than 24 inches and deflection shall not exceed L/480.</u></p>
<b>R302.1</b> <b>Exterior walls</b>	<p>Construction, projections, openings and penetrations of <i>exterior walls</i> of <i>dwellings</i> and accessory buildings shall comply with Table R302.1.</p> <p><b>Exceptions:</b></p> <ol style="list-style-type: none"> <li>1. Walls, projections, openings or penetrations in walls perpendicular to the line used to determine the <i>fire separation distance</i>. <u>Townhouse projections shall comply with R302.2.5.</u></li> <li>2. Walls of <i>dwellings</i> and <i>accessory buildings</i> located on the same <i>lot</i>.</li> <li>3. Detached tool sheds and storage sheds, playhouses and similar structures exempted from permits are not required to provide wall protection based on location on the <i>lot</i>. Projections beyond the <i>exterior wall</i> shall not extend over the <i>lot line</i>.</li> <li>4. Detached garages accessory to a <i>dwelling</i> located within 2 feet (610 mm) of a <i>lot line</i> are permitted to have roof eave projections not exceeding 4 inches (102 mm).</li> <li>5. Foundation vents installed in compliance with this code are permitted.</li> </ol>
<b>R302.2.2</b> <b>Parapets</b>	<p>Parapets constructed in accordance with Section R302.2.3 shall be constructed for townhouses as an extension of exterior walls or common walls in accordance with the following:</p> <ol style="list-style-type: none"> <li>1. Where roof surfaces adjacent to the wall or walls are at the same elevation, the parapet shall extend not less than 30 inches (762 mm) above the roof surfaces.</li> <li>2. Where roof surfaces adjacent to the wall or walls are at different elevations and the higher roof is not more than 30 inches (762 mm) above the lower roof, the parapet shall extend not less than 30 inches (762 mm) above the lower roof surface.</li> </ol> <p><b>Exception:</b> A parapet is not required in the two cases above when the roof is covered with a minimum class C roof covering, and the roof decking or sheathing is of noncombustible materials or approved fire-retardant-treated wood for a distance of 4 feet (1219 mm) on each side of the wall or walls, or one layer of 5/8-inch (15.9 mm) Type X gypsum board is installed directly beneath the roof decking or sheathing, supported by a minimum of nominal 2-inch (51 mm) ledgers attached to the sides of the roof framing members, for a minimum distance of 4 feet (1220 mm) on each side of the wall or walls. <u>No openings or penetrations including dormers allowed within this 4' protected area.</u></p>
<b>R302.2.5</b> <b>Townhouse eave protection</b>	<p><u>In townhouse construction (with three or more attached dwellings) Projections extending into the fire separation distance shall have not less than 1 hour fire resistive construction on the underside. Soffit material beyond the fire separation distance shall be securely attached to framing members and shall be constructed using either noncombustible soffit material; fire-retardant-treated soffit material; vinyl soffit installed over 3/4-inch (19 mm) wood sheathing or 5/8-inch (16 mm) gypsum board; or aluminum soffit installed over 3/4-inch (19 mm) wood sheathing or 5/8-inch (16 mm) gypsum board. Venting requirements shall be provided in both soffit and underlayments. Vents shall be either nominal 12-inch (51 mm) continuous or equivalent intermittent and shall not exceed the minimum net free air requirements established in Section R806.2 by more than 50 percent.</u></p> <p>Vents in soffit are not allowed within 4 feet (1219 mm) of fire walls or property lines.</p>
<b>R302.2.6</b> <b>Townhouse eave</b>	<p><u>Overhang projections not exceeding 12 inches shall be allowed to extend beyond the property line in townhouse buildings provided all the following conditions are met:</u></p> <ol style="list-style-type: none"> <li>1. <u>Required fire resistant rated wall assembly is tight to roof deck; and</u></li> </ol>



projections	<p>2. <u>Eaves shall be protected with roof decking and fascia of non-combustible materials or approved fire-retardant-treated wood; and</u></p> <p>3. <u>Eaves shall have not less than 1 hour fire-resistive construction on the underside.</u></p>
R302.2.7 Flame Spread	<p><u>Vinyl Siding and vinyl soffit materials when used in townhouse construction shall have a Flame Spread Index of 25 or less as tested in accordance with ASTM E-84.</u></p>
R302.2.8 Sound Transmission	<p><u>See Appendix K.</u></p>
R305.1 Ceiling Height	<p><b>Add exception under section R305.1 Ceiling Height</b></p> <p>3. Beams and girders spaced not less than 4 feet (1219mm) on center may project not more than 6 inches (152 mm) below the required ceiling height.</p>
R308.1 Identification	<p><b>R308.1 Identification.</b> Except as indicated in Section R308. 1.1 each pane of glazing installed in hazardous locations as defined in Section R308.4 shall be provided with a manufacturer’s designation specifying who applied the designation, designating the type of glass and the safety glazing standard with which it complies, which is visible in the final installation. The designation shall be acid etched, sandblasted, ceramic-fired, laser etched, embossed, or be of a type which once applied cannot be removed without being destroyed.</p> <p><b>Exceptions:</b></p> <ol style="list-style-type: none"> <li>1. For other than tempered glass, manufacturer’s designations are not required provided the building official approves the use of a certificate, affidavit or other evidence confirming compliance with this code.</li> <li>2. Tempered spandrel glass is permitted to be identified by the manufacturer with a removable paper designation.</li> </ol>
R308.4 Hazardous locations	<p><b>R308.4 Hazardous locations.</b></p> <p><b>Remove “arc” from item #2</b></p>
R310.1.1 Minimum opening area	<p>All emergency escape and rescue openings shall have a <u>minimum net clear openable area of 4 square feet (0.372 m<sup>2</sup>)</u> The minimum net clear opening height shall be 22 inches (558 mm). The minimum net clear opening width shall be 20 inches (508 mm). Emergency escape and rescue openings must have a <u>mini-mum total glazing area of not less than 5 square feet (0.465m<sup>2</sup>) in the case of a ground floor level window and not less than 5.7 square feet (0.530 m<sup>2</sup>) in the case of an upper story window.</u></p>
R311.1 Means of egress	<p>All <i>dwelling</i>s shall be provided with a means of egress as provided in this section. The means of egress shall provide a continuous and unobstructed path of vertical and horizontal egress travel from all portions of the <i>dwelling</i> to the exterior of the <i>dwelling</i> at the required <b>exterior</b> egress door without requiring travel through a garage.</p> <p><b><u>Exception: Equipment service platforms may be served by ladders constructed per R310.2.1.</u></b></p>
R311.2 Egress door	<p>At least one <b>exterior</b> egress door shall be provided for each <i>dwelling</i> unit. The egress door shall be side-hinged, and shall provide a minimum clear width of 32 inches (813mm) when measured between the face of the door and the stop, with the door open 90 degrees (1.57 rad). The minimum clear height of the door opening shall not be less than 78 inches (1981 mm) in height measured from the top of the threshold to the bottom of the stop. Other <b>exterior</b> doors shall not be required to comply with these minimum dimensions. <b><u>All interior and exterior egress doors shall be readily openable from the side from which egress is to be made</u></b> without the use of a key or special knowledge or effort.</p>
R311.3.1 Floor elevations at	<p>Landings or floors at the required egress door shall not be more than 1 1/2 inches (38 mm) lower than the top of the threshold.</p> <p><b>Exception:</b> The exterior landing or floor shall not be more than <b><u>8 1/4 (210 mm)</u></b> below the top of the</p>

the required egress doors	threshold provided the door does not swing over the landing or floor. When exterior landings or floors serving the required egress door are not at <i>grade</i> , they shall be provided with access to <i>grade</i> by means of a ramp in accordance with Section R311.8 or a stairway in accordance with Section R311.7.
R311.3.2 Floor elevations for other exterior doors	<b>R311.3.2 Floor elevations for other exterior doors.</b> Doors other than the required egress door shall be provided with landings or floors not more than <b>8 1/4 (210 mm)</b> below the top of the threshold. <b>Exception:</b> A landing is not required where a stairway <b>of two or fewer risers</b> is located on the exterior side of the door, provided the door does not swing over the stairway.
R311.5 Construction	<u>Delete</u>
R311.5.1 Attachment	Delete
R311.6.1 Hallways	The minimum width of a hallway shall be not less than 3 feet (914 mm) <u>measured from the finish surface of the walls.</u>
R311.6.2 Interior doors	<u>All doors providing egress from habitable rooms shall have nominal minimum dimensions of 2 feet 6 inches (762 mm) width by 6 feet 8 inches (2032 mm) height.</u>
R311.7.3	Delete
R311.7.4.1 Riser height	<u>The maximum riser height shall be 8 1/4 inches (210 mm). The riser shall be measured vertically between leading edges of the adjacent treads. The greatest riser height within any flight of stairs shall not exceed the smallest by more than 3/8 inch (9.5mm). The top and bottom riser of interior stairs shall not exceed the smallest riser within that stair run by more than 3/4 inch (19 mm). The height of the top and bottom riser of the interior stairs shall be measured from the permanent finished surface (carpet excluded). Where the bottom riser of an exterior stair adjoins an exterior walk, porch, driveway, patio, garage floor, or finish grade, the height of the riser may be less than the height of the adjacent risers.</u>
R311.7.4.2 Tread depth	<u>The minimum tread depth shall be 9 inches (229 mm). The tread depth shall be measured horizontally between the vertical planes of the foremost projection of adjacent treads and at a right angle to the tread's leading edge. The greatest tread depth within any flight of stairs shall not exceed the smallest by more than 3/8 inch (9.5 mm). Winder treads shall have a minimum tread depth of 9 inches (229 mm) measured as above at a point 12 inches (305) mm from the side where the treads are narrower. Winder treads shall have a minimum tread depth of 4 inches (102 mm) at any point. Within any flight of stairs, the greatest winder tread depth at the 12 inch (305 mm) walk line shall not exceed the smallest by more than 3/8 inch (9.5 mm).</u>
R311.7.6 Stairway walking surface	The walking surface of treads and landings of stairways shall be sloped no steeper than one <del>unit</del> <u>inch</u> vertical in 48 inches horizontal (2-percent slope).
R311.7.7.2 Continuity	Handrails for stairways shall be continuous for the full length of the flight, from a point directly above the top riser of the flight to a point directly above lowest riser of the flight. Handrail ends shall be returned or shall terminate in newel posts or safety terminals. Handrails adjacent to a wall shall have a space of not less than 1 1/2 inch (38 mm) between the wall and the handrails. <b>Exceptions:</b> <ol style="list-style-type: none"> <li>1. Handrails shall be permitted to be interrupted by a newel post. <del>at the turn.</del></li> <li>2. The use of a volute, turnout, starting easing or starting newel shall be allowed over the lowest tread.</li> <li>3. <u>Two or more separate rails shall be considered continuous if the termination of the rails occurs within 6 inches (152 mm) of each other. If transitioning between a wall-</u></li> </ol>

	<u>mounted handrail and a guardrail/handrail, the wall-mounted rail must return into the wall.</u>
<b>R311.7.7.3 Grip-size</b>	<p>All required handrails shall be of one of the following types or provide equivalent graspability:</p> <ol style="list-style-type: none"> <li>1. Type I. Handrails with a circular cross section shall have an outside diameter of at least 1 1/4 inches (32 mm) and not greater than 2 inches (51 mm). If the handrail is not circular, it shall have a perimeter dimension of at least 4 inches (102 mm) and not greater than 6 1/4 inches (160 mm) with a maximum cross section of dimension of 2 1/4 inches (57 mm). Edges shall have a minimum radius of 0.01 inch (0.25 mm).</li> <li>2. Type II. Handrails with a perimeter greater than 6 1/4 inches (160 mm) shall have a graspable finger recess area on both sides of the profile. The finger recess shall begin within a distance of 3/4 inch (19mm) measured vertically from the tallest portion of the profile and achieve a depth of <ul style="list-style-type: none"> <li>at least 5/16 inch (8 mm) within 7/8 inch (22 mm) below the widest portion of the profile. This required depth shall continue for at least 3/8 inch (10 mm) to a level that is not less than 13/4 inches (45 mm) below the tallest portion of the profile. The minimum width of the handrail above</li> <li>the recess shall be 1 1/4 inches (32 mm) to a maximum of 2 3/4 inches (70 mm). Edges shall have a minimum radius of 0.01 inch (0.25 mm).</li> </ul> </li> </ol> <p><b><u>Exception:</u></b> Exterior handrails (garages and areas exposed to the weather) shall not be more than <u>3 1/2 inches (89 mm) in cross-section dimension.</u></p>
<b>R311.7.9 Special stairways</b>	Spiral stairways, <del>and</del> bulkhead enclosure stairways <u>and bowed tread stairways</u> shall comply with all requirements of section R311.7 except as specified below.
<b>R311.7.9.3 Bowed tread stairways</b>	<u>Bowed tread stairways are permitted provided they are uniform in bowed tread depth along entire width of tread with not more than 3/8" variance from greatest to smallest tread in the stairway flight. At no point shall the tread be less than a minimum of 9 inches with a nosing as listed in section R311.7.4.2 and R311.7.4.3 respectfully.</u>
<b>R311.7.9.3.1 Standard stairway application</b>	<u>The bottom 3 treads in a standard straight run stairway application as listed under section R311.7.4.2 are permitted to bow provided at no point along the width of the tread they are less than 9" as measured under section R311.7.4.2 and each bowed tread is uniformed with other bowed treads with no more than 3/8" variance from greatest to least. Nosing is required as listed in section R311.7.4.</u>
<b>R311.7.9.3.2 Bowed tread circular stairways</b>	<b><u>R311.7.9.3.2 Bowed tread circular stairways.</u></b> <u>Bowed treads in a circular stairway are permitted provided they are uniformed as per winder treads as listed in section R311.7.4.2 measured at a point 12" from the side where the treads are narrower. At this walk line bowed treads must be uniformed with other circular stairway treads with the greatest tread not to exceed the smallest by more than 3/8". Nosing is required as listed in section R311.7.4.</u>
<b>R313.1 Townhouse Automatic fire sprinkler systems</b>	<p>An automatic residential fire sprinkler system shall be installed in <u>townhouse buildings with 3 or more attached dwellings.</u></p> <p>Exception: An automatic residential fire sprinkler system shall not be required when additions or alterations are made to existing townhouses that do not have an automatic residential fire sprinkler system installed.</p>
<b>R313.2 One and two family dwellings automatic fire</b>	<b>Delete</b>

<b>systems</b>	
<b>R313.2.1 Design and installation</b>	<b>Delete</b>
<b>R314.3.1 Alterations, repairs and additions</b>	When alterations, repairs and additions requiring a <u>building</u> permit occur, or when one or more sleeping rooms are added or created in existing dwellings, the individual dwelling unit shall be equipped with smoke alarms located as required for new dwellings; the smoke alarms shall be interconnected and hard wired.
<b>R314.4 Power source</b>	<b>R314.4 Power source</b> (same as IRC2009)  <b>Exceptions:</b> 1. (no change) 2. Interconnection and hard-wiring of smoke alarms in existing areas shall not be required where the alterations or repairs do not result in the removal of interior wall or ceiling finishes exposing the structure, <del>unless there is an attic, crawl space or basement available which could provide access for hard wiring and interconnection without the removal of interior finishes.</del> Smoke alarm locations are required per Section R314.2, but may be battery powered and shall be designed to emit a recurring signal when batteries are low and need to be replaced.
<b>R315.1 Carbon monoxide alarms</b>	In new construction, dwelling units shall be provided with an approved carbon monoxide alarm installed outside of each separate sleeping area in the immediate vicinity of the bedroom(s).
<b>R315.2 Where required in existing dwellings</b>	In existing dwellings, where interior alterations, repairs, fuel-fired appliance replacements or additions work requiring a permit occurs, or where one or more sleeping rooms are added or created, carbon monoxide alarms shall be provided in accordance with Section 315.1.
<b>R315.3 Alarm requirements</b>	The required carbon monoxide alarms shall be clearly audible in all bedrooms over background noise levels with all intervening doors closed. Single station carbon monoxide alarms shall be listed as complying with UL 2034 and shall be installed in accordance with this code and the manufacturer's installation instructions.
<b>R316.7 Termite damage</b>	The use of foam plastics in areas of " <u>Moderate-Heavy</u> " termite infestation probability shall be in accordance with Section R318.4.
<b>R317.1 Location required</b>	Protection of wood and wood based products from decay shall be provided in the following locations by the use of naturally durable wood or wood that is preservative-treated in accordance with AWPA U1 for the species, product, preservative and end use. Preservatives shall be listed in Section 4 of AWPA U1 <ol style="list-style-type: none"> <li>1. Wood joists or the bottom of a wood structural floor when closer than 18 inches (457 mm) or wood girders when closer than 12 inches (305 mm) to the exposed ground in crawl spaces or unexcavated area located within the periphery of the building foundation.</li> <li>2. All <del>wood framing members</del> <u>exterior sills and plates</u> that rest on concrete or masonry exterior foundation walls and are less than 8 inches (203 mm) from the exposed ground.</li> <li>3. Sills and sleepers on a concrete or masonry slab, <u>unless the slab</u> that is in direct contact with the ground <u>is separated from the ground</u> <del>unless separated from such slab</del> by an <u>approved</u> impervious moisture barrier.</li> <li>4. The ends of wood girders entering exterior masonry or concrete walls having clearances of less than 0.5 inch (12.7 mm) on tops, sides and ends.</li> <li>5. Wood siding <u>and</u> sheathing <del>and wall framing</del> on the exterior of a building having a clearance of</li> </ol>

	<p>less than 6 inches (152 mm) from the ground.</p> <p>6. Wood structural members supporting moisture-permeable floors or roofs that are exposed to the weather, such as concrete or masonry slabs, unless separated from such floors or roofs by an impervious moisture barrier.</p> <p>7. Wood furring strips or other wood framing members attached directly to the interior of exterior masonry walls or concrete walls below grade except where an approved vapor retarder is applied between the wall and the furring strips or framing members.</p> <p>8. <u>All portions of a porch, screen porch or deck from the bottom of the header down, including posts, guardrails, pickets, steps, and floor structure. Coverings that would prevent moisture or water accumulation on the surface or at joints between members are allowed.</u></p> <p>Exception: <u>Columns complying with R317.1.1, Exception #2</u></p>
<b>R317.1.1 Field treatment</b>	<del>Field cut ends, notches and drilled holes of preservative treated wood shall be treated in the field in accordance with AWPA M4. Deleted.</del>
<b>R317.1.3 Geographical areas</b>	<b>Delete</b>
<b>R317.1.4 Wood Columns</b>	<p><b>Wood columns.</b> Wood columns shall be <i>approved</i> wood of natural decay resistance or <i>approved</i> pressure-preservative-treated wood.</p> <p><b>Exceptions:</b></p> <p>1. Columns <del>exposed to the weather or in basements</del> when supported by concrete piers or metal pedestals projecting 1 inch (25.4 mm) above a concrete floor <del>or 6 inches (152 mm) above exposed earth and the earth is covered by</del> <u>with an approved impervious moisture barrier installed between the slab and earth.</u></p> <p>2. <u>Columns exposed to the weather when all of the following conditions are met:</u></p> <p><u>a. The column is supported by piers or metal pedestals projecting 1 inch (25.4 mm) above a concrete floor or 6 inches (152mm) above exposed earth and the earth is covered by an approved impervious moisture barrier;</u> <u>and</u></p> <p><u>b. There is no joints in or between structural members (from the header to the base of the column); and</u></p> <p><u>c. The column is protected from exposure to surface moisture at the top by a roof, eave, or overhang; and</u></p> <p><u>d. The exterior surface of the column is fully sealed (paint, sealer, etc..) against moisture intrusion.</u></p> <p>3. Columns in enclosed crawl spaces or unexcavated areas located within the periphery of the building when supported by a concrete pier or metal pedestal at a height more than 8 inches (203mm) from exposed earth and the earth is covered by an impervious moisture barrier.</p>
<b>R318.1 Protection against subterranean termites</b>	<b>Delete item #5 only</b>
<b>R318.1.2 Field Treatment</b>	<b>Delete</b>
<b>R318.2 Chemical soil treatment</b>	The concentration, rate of application and treatment method of the termiticide shall be consistent with and never less than the termiticide label <u>and applied according to the standards of the North Carolina Department of Agriculture.</u>
<b>R318.3 Barriers</b>	<b>Delete</b>
<b>R318.4 Foam plastic protection</b>	<u>This section shall apply to both treated and untreated foam plastic</u>
<b>R318.4.1</b>	<u>All foam plastic shall be a minimum of 8 inches (203 mm) above grade See Appendix 0</u>

<b>Foundation walls</b>	<u>Exception: Foam plastic less than 8 inches (203 mm) above or in contact with grade shall be installed in accordance with Section 318.5.5 and Appendix 0</u>
<b>R318.4.2 Termite control</b>	<u>When foam plastic is in contact with the ground subterranean termite control shall be in accordance with Section 318.1</u>
<b>R318.4.3 Slab on grade (non-structural)</b>	<u>Foam plastic shall be installed along the vertical edge and underneath the slab as specified in Section R318.5.5</u>
<b>R318.4.4 slab on grade (structural)</b>	<u>All slabs which distribute the wall loads to the foundation shall be insulated as specified in this section. Foam plastic shall be installed along the vertical edge and underneath grade as specified in Appendix 0 Figure 0-3</u>
<b>R318.4.5</b>	<u>Foam plastic in contact with ground.</u>
<b>R318.4.5.1 Inspection and treatment gaps</b>	<u>Foam plastic in contact with the ground shall not be continuous to the bottom of the weather-resistant siding. A clear and unobstructed 2-inch (51 mm) minimum inspection gap shall be maintained from the bottom of the weather-resistant siding to the top of any foam plastic. A minimum 4-inch (102 mm) treatment gap shall be provided beginning not more than 6 inches (152 mm) below grade. The top and bottom edges of the foam plastic installed between the inspection gap and the treatment gap shall be cut at a 45-degree (0.79 rad) angle. See Appendix 0</u> <u>Exception: For ICF foundations see Section R404.4.7.2</u>
<b>R318.4.5.2 Protection of exposed foam plastic</b>	<u>Exposed foam plastic shall be protected from physical damage. The required inspection gap foam plastic and treatment gap shall be on the exterior with a cementitious coating that extends at least 2 inches (51 mm) below the foam plastic onto the surface of the foundation wall. See Appendix 0.</u>
<b>R318.4.5.3 Waterproofing foam plastic between inspection gap and treatment gap</b>	<u>Waterproofing shall be installed over the required cementitious coating from 6 inches (152 mm) above grade to the treatment gap per manufacturer's installation instructions.</u>
<b>R318.4.5.4 Dampproofing of below grade walls</b>	<u>Any foam plastic applied below the treatment gap shall be installed after required foundation wall dampproofing is in place. See section R406 and Appendix O.</u>
<b>R321.1 Elevators</b>	Where provided elevators shall comply with ASME A17.1.
<b>R321.2 Platform lifts</b>	Where provided, platform lifts shall comply with ASME A18.1.
<b>R321.3 Accessibility</b>	Deleted
<b>R321.4</b>	The installer shall certify that the following conditions have been met.

<b>Certification</b>	<p>1. The elevator or platform lift has been installed in accordance with the manufacturer's installation instructions.</p> <p>2. The elevator meets the requirements of ASME A17.1, Part 5, Section 5.3 and other applicable parts.</p> <p>3. <u>The elevator or platform lift meets the requirements of the <i>North Carolina Electrical Code</i>. Before a Certificate of Occupancy is issued, the permit holder shall provide the code enforcement official a letter of certification from the installer, evidencing compliance with the above conditions. Any maintenance requirements required by the manufacturer shall be stated and affixed to the component. When an elevator or platform lift or its components has been serviced, the service provider shall certify to the owner that the elevator continues to meet the above conditions.</u></p>
----------------------	---

<b>R322.1 General</b>	Buildings and structures constructed in whole or in part in flood hazard areas (including A or V Zones) as established in Table R301.2(1) shall be designed and constructed in accordance with the provisions contained in this section. <u>See additional provisions of Chapter 46.</u>
-----------------------	--

<b>R322.2.1 Elevation requirements</b>	<p><b>Elevation requirements.</b></p> <p>1. Buildings and structures shall have the lowest floors elevated to or above the <u>base flood elevation plus one foot (305mm)</u>, or the design flood elevation, <u>whichever is higher</u>.</p> <p>2. In areas of shallow flooding (AO Zones), buildings and structures shall have the lowest floor (including basement) elevated at least as high above the highest adjacent grade as the depth number specified in feet (mm) on the FIRM <u>plus one foot (305mm)</u>, or at least <u>3 feet (915 mm)</u> if a depth number is not specified.</p> <p>3. Basement floors that are below grade on all sides shall be elevated to or above the <u>base flood elevation plus one foot (305mm)</u>, or the design flood elevation, <u>whichever is higher</u>.</p> <p><b>Exception:</b> Enclosed areas below the design flood elevation' including basements whose floors are not below grade on all sides, shall meet the requirements of Section R322.2.2.</p>
--	--

<b>R322.3.1</b>	<b>Delete</b>
-----------------	---------------

## Chapter 4 Foundations

<b>R401.4.1 Geotechnical evaluation</b>	<b>In lieu of a complete geotechnical evaluation, the load-bearing values in Table R401.4.1 shall be assumed.—<u>The load bearing values greater than 2000 psf in Table R401.4.1 require an engineering evaluation.</u></b>
---	---

<b>Table R401</b>	<b>TABLE R401.4.1 PRESUMPTIVE LOAD-BEARING VALUES OF FOUNDATIONS MATERIALS<sup>a</sup></b>												
	<table border="1" style="width: 100%;"> <thead> <tr> <th style="text-align: center;">Class of Material</th> <th style="text-align: center;">Load-Bearing Pressure (pounds per square foot)</th> </tr> </thead> <tbody> <tr> <td>Crystalline bedrock</td> <td style="text-align: center;">12,000</td> </tr> <tr> <td>Sedimentary and foliated rock</td> <td style="text-align: center;"><u>6,000</u></td> </tr> <tr> <td>Sandy gravel and/or gravel (GW and GP)</td> <td style="text-align: center;"><u>5,000</u></td> </tr> <tr> <td>Sand, silty sand, clayey sand, silty gravel and clayey gravel (SW, SP, SM, SC, GM and GC)</td> <td style="text-align: center;"><u>3,000</u></td> </tr> <tr> <td>Clay, sandy clay, silty clay, clayey silt, silt and sandy silt (CL, ML, MH and CH)</td> <td style="text-align: center;"><u>2,000<sup>b</sup></u></td> </tr> </tbody> </table>	Class of Material	Load-Bearing Pressure (pounds per square foot)	Crystalline bedrock	12,000	Sedimentary and foliated rock	<u>6,000</u>	Sandy gravel and/or gravel (GW and GP)	<u>5,000</u>	Sand, silty sand, clayey sand, silty gravel and clayey gravel (SW, SP, SM, SC, GM and GC)	<u>3,000</u>	Clay, sandy clay, silty clay, clayey silt, silt and sandy silt (CL, ML, MH and CH)	<u>2,000<sup>b</sup></u>
Class of Material	Load-Bearing Pressure (pounds per square foot)												
Crystalline bedrock	12,000												
Sedimentary and foliated rock	<u>6,000</u>												
Sandy gravel and/or gravel (GW and GP)	<u>5,000</u>												
Sand, silty sand, clayey sand, silty gravel and clayey gravel (SW, SP, SM, SC, GM and GC)	<u>3,000</u>												
Clay, sandy clay, silty clay, clayey silt, silt and sandy silt (CL, ML, MH and CH)	<u>2,000<sup>b</sup></u>												
<p>For SI: 1 pound per square foot = 0.0479 kN/m<sup>2</sup>.</p> <p>a. When soil tests are required by Section R401.4, the allowable bearing capacities of the soil shall be part of the recommendations.</p> <p>b. Where the building official determines that in—place soils with an allowable bearing capacity of less than <del>4,500</del> <b>2000</b> psf are likely to be present at the site, the allowable bearing capacity shall be determined by a soils investigation.</p>													

**Table R403.1**

**TABLE R403.1  
MINIMUM WIDTH OF CONCRETE OR  
MASONRY FOOTINGS  
(inches)<sup>a</sup>**

	LOAD-BEARING VALUE OF SOIL (psf)			
	1,500	2,000	3,000	4,000
<b>Conventional light-frame construction</b>				
1-story	<b>16<sup>b</sup></b>	<b>16<sup>b</sup></b>	12	12
2-story	<b>16<sup>b</sup></b>	<b>16<sup>b</sup></b>	12	12
3-story	23	17	12	12
<b>4-inch brick veneer over light frame or 8-inch hollow concrete masonry</b>				
1-story	<b>16<sup>b</sup></b>	<b>16<sup>b</sup></b>	12	12
2-story	21	16	12	12
3-story	32	24	16	12
<b>8-inch solid or fully grouted masonry</b>				
1-story	16	<b>16<sup>b</sup></b>	12	12
2-story	29	21	14	12
3-story	42	32	21	16

For SI: 1 inch = 25.4 mm, 1 pound per square foot = 0.0479 kPa.  
 a. Where minimum footing width is 12 inches, use of a single wythe of solid or fully grouted 12-inch nominal concrete masonry units is permitted.  
 b. A minimum footing width of 12" is acceptable for monolithic slab foundations.

**Table 403.1a  
Pier and  
footing sizes  
for support  
girders**

**Insert table from NC 2009 code**

**TABLE R403.1a  
PIER<sup>1</sup> AND FOOTING<sup>2</sup> SIZES FOR SUPPORT OF GIRDERS**

Area <sup>5</sup>	1 (One) STORY		2 (Two) STORY		2-1/2 (Two & One Half) STORY	
	Pier <sup>3,4</sup>	Footing	Pier <sup>3,4</sup>	Footing	Pier <sup>3,4</sup>	Footing
50	8" x 16"	1'-4" x 2'-0" x 8"	8" x 16"	1'-4" x 2'-6" x 8"	8" x 16"	1'-4" x 2'-6" x 8"
100	8" x 16"	1'-4" x 2'-0" x 8"	8" x 16"	2'-0" x 2'-0" x 10"	16" x 16"	2'-6" x 2'-6" x 10"
150	8" x 16"	2'-0" x 2'-0" x 8"	16" x 16"	2'-8" x 2'-8" x 10"	16" x 16"	3'-0" x 3'-0" x 10"
200	8" x 16"	2'-4" x 2'-4" x 10"	16" x 16"	3'-0" x 3'-0" x 10"	16" x 16"	3'-11" x 3'-8" x 1'-0"
250	—	—	16" x 16"	3'-4" x 3'-4" x 1'-0"	16" x 24"	4'-0" x 4'-0" x 1'-0"
300	—	—	16" x 16"	3'-8" x 3'-8" x 1'-0"	16" x 24"	4'-6" x 4'-6" x 1'-0"

For SI: 1 inch = 25.4 mm, 1 foot = 304.8 mm, 1 pound per square inch = 6.895 kPa, 1 pound per square foot = 0.0479 kPa.  
 1. Pier sizes are based on hollow CMU capped with 4 inches of solid masonry or concrete for 1 (one) story and 8 inches of solid masonry or concrete for 2 (two) and 2-1/2 (two and one half) story houses or shall have cavities of the top course filled with concrete or grout or other approved methods. Mortar shall be Type S.  
 2. Footing sizes are based on 2000 psf allowable soil bearing and 2500 psi concrete. This table is based upon the limitations of a tributary area using dimensional framing lumber only.  
 3. Centers of piers shall bear in the middle one-third of the footings. Girders must have full bearing on piers. Footings shall be full thickness over the entire area of the footing.  
 4. Pier sizes given are minimum. For height/thickness limitations see Section R606.6.  
 5. Area at first level supported by pier and footing (sq. ft.).

- R403.1.2**
- R403.1.3**
- R403.1.3.1**
- R403.1.3.2**
- R403.1.4.2**

**Delete**



Figure R403.1  
(1)

**FIGURE R403.1(1)  
CONCRETE AND MASONRY FOUNDATION DETAILS**

*Replace with the 2009 NCRC, remove word "finished" in Note 1.*

FIGURE R403.1(1)

FOUNDATIONS

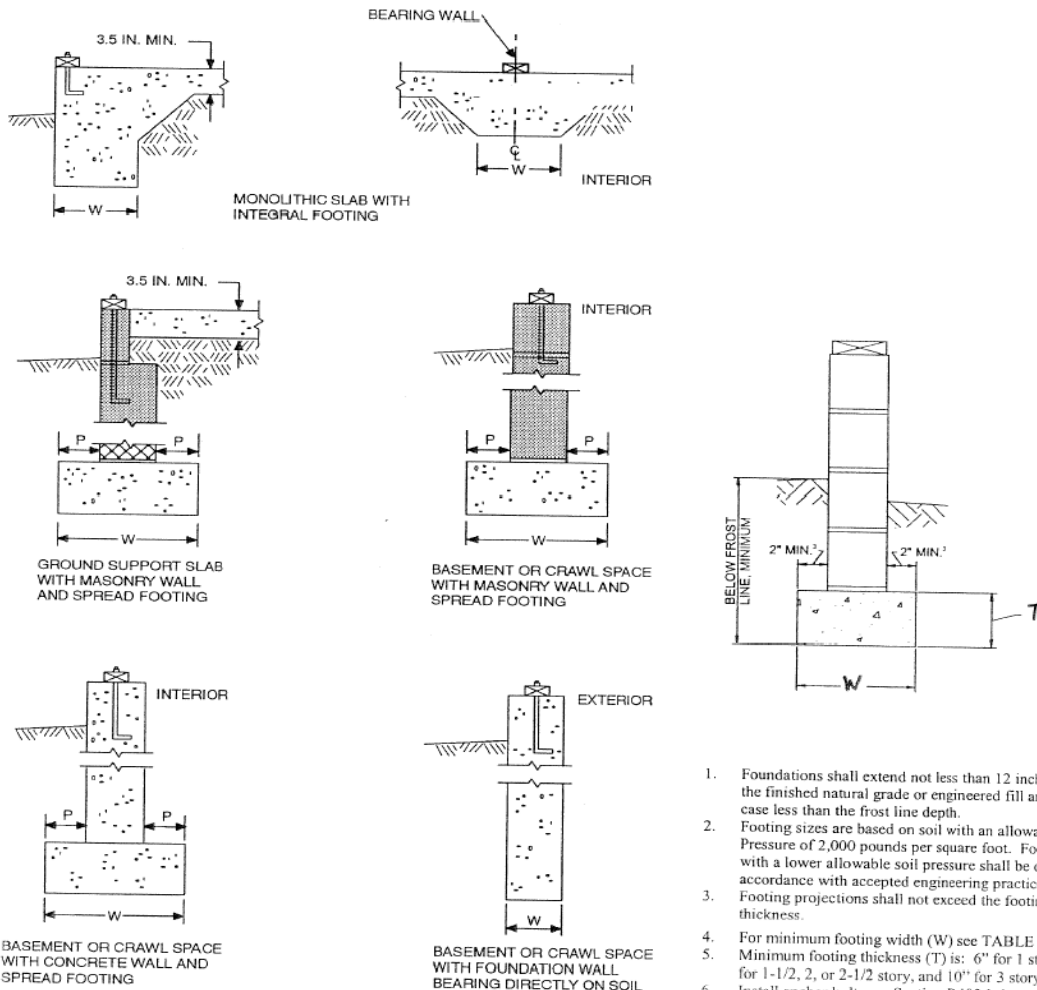

1. Foundations shall extend not less than 12 inches below the finished natural grade or engineered fill and in no case less than the frost line depth.
2. Footing sizes are based on soil with an allowable soil Pressure of 2,000 pounds per square foot. Footings on soil with a lower allowable soil pressure shall be designed in accordance with accepted engineering practice.
3. Footing projections shall not exceed the footing thickness.
4. For minimum footing width (W) see TABLE R403.1
5. Minimum footing thickness (T) is: 6" for 1 story, 8" for 1-1/2, 2, or 2-1/2 story, and 10" for 3 story.
6. Install anchor bolts per Section R403.1.6.

or SI: 1 inch = 25.4 mm.

FIGURE R403.1(1)  
CONCRETE AND MASONRY FOUNDATION DETAILS

Figure  
R403.1.3.2

Delete

R403.1.4  
Minimum  
depth

All exterior footings and foundation systems shall extend below the frost line specified in Table R301.2(1). In no case shall the bottom of the exterior footings be less than 12 inches below the undisturbed ground surface or engineered fill. be placed at least 12 inches (305 mm) below the undisturbed ground. Where applicable, the depth of footings shall also conform to Sections R403.1.4.1 through R403.1.4.2.

	<u><b>Exception:</b> Frost protected footings constructed in accordance with Section R403.3 and footings and foundations erected on solid rock shall not be required to extend below the frost line.</u>
<b>R403.1.4.1 Frost protection</b>	<u><b>Deleted</b></u>
<b>R403.1.5 Slope</b>	The top surface of footings shall be level ( <u>1/2 inch in 10 feet</u> ) <del>or shall be brought level, under the width of the wall, with masonry units with full mortar joints.</del> The bottom surface of footings <u>may</u> <del>shall not</del> have a slope <u>not</u> exceeding one unit vertical in 10 units horizontal (10-percent slope). Footings shall be stepped where it is necessary to change the elevation of the top surface of the footings or where the slope of the bottom surface of the footings will exceed one unit vertical in ten units horizontal (10-percent slope).
<b>R403.1.6 Foundation anchorage</b>	When braced wall panels are supported directly on continuous foundations, the wall wood sill plate or cold-formed steel bottom track shall be anchored to the foundation in accordance with this section. The wood sole plate at exterior walls on monolithic slabs and wood sill plate shall be anchored to the foundation with anchor bolts spaced a maximum of 6 feet (1829 mm) on center <u>and not more than 12 inches from the corner.</u> <b>There shall be a minimum of two bolts per plate section.</b> <del>with one bolt located not more than 12 inches (305 mm) or less than seven bolt diameters from each end of the plate section.</del> In Seismic Design Categories D1 and D2, anchor bolts shall also be spaced at 6 feet (1829 mm) on center and located within 12 inches (305 mm) from the ends of each plate section at interior braced wall lines when required by Section R602.10.9 to be supported on a continuous foundation. Bolts shall be at least 1/2 inch (12.7 mm) in diameter and shall extend a minimum of 7 inches (178 mm) into masonry or concrete. Interior bearing wall sole plates on monolithic slab foundations shall be positively anchored with approved fasteners. A nut and washer shall be tightened on each bolt to the plate. Sills and sole plates shall be protected against decay and termites where required by Sections R318 and R319. Cold-formed steel framing systems shall be fastened to the wood sill plates or anchored directly to the foundation as required in Section R505.3.1 or R603.1.1.  <b>Exceptions as listed in IRC2009-ok</b>
<b>R403.1.6.1 Foundation anchorage in Seismic Design Categories C,D1 and D2</b>	In addition to the requirements of Section R403.1.6, the following requirements shall apply to wood light-frame structures in Seismic Design Categories D1 and D2 and wood light-frame townhouses in Seismic Design Category C. <ol style="list-style-type: none"> <li>1. Plate washers conforming to Section R602.11.1 shall be used on each bolt.</li> <li>2. Interior braced wall plates shall have anchor bolts spaced at not more than 6 feet (1829 mm) on center and <del>located within</del> <u>not more than 12 inches (305 mm) from the corner.</u> <del>ends of each plate section when supported on a continuous foundation.</del></li> <li>3. Interior bearing wall sole plates shall have anchor bolts spaced at not more than 6 feet (1829 mm) on center and <del>located within</del> <u>not more than 12 inches (305 mm) from the corner.</u> <del>ends of each plate section when supported on a continuous foundation.</del></li> <li>4. The maximum anchor bolt spacing shall be 4 feet (1219 mm) for buildings over two stories in height.</li> <li>5. Stepped cripple walls shall conform to Section R602.11.3.</li> <li>6. Where continuous wood foundations in accordance with Section R404.2 are used, the force transfer shall have a capacity equal to or greater than the connections required by Section R602.11.1 or the braced wall panel shall be connected to the wood foundations in accordance with the braced wall panel-to-floor fastening requirements of Table 602.3(1).</li> </ol>
<b>Figure R403.1.7.1</b>	Delete

R403.1.7	Deleted
R403.1.7.1	Deleted
R403.1.7.2	Deleted
R403.1.7.3	Deleted
R403.1.7.4	Deleted
R403.1.8	Deleted
R403.1.8.1	Deleted
R403.3	Deleted
Table R403.3	<del>DELETED TABLE R403.3 MINIMUM INSULATION REQUIREMENTS FOR FROST-PROTECTED FOOTINGS IN HEATED BUILDINGS<sup>a</sup></del>
Figure R403.3 (1)	<del>DELETED FIGURE R403.3(1) INSULATION PLACEMENT FOR FROST-PROTECTED FOOTINGS IN HEATED BUILDINGS</del>
Figure R403.3 (3)	<del>Delete FIGURE R403.3(3) INSULATION PLACEMENT FOR FROST-PROTECTED FOOTINGS ADJACENT TO UNHEATED SLAB-ON-GROUND STRUCTURE</del>
Figure R403.3 (4)	<del>Delete FIGURE R403.3(4) INSULATION PLACEMENT FOR FROST-PROTECTED FOOTINGS ADJACENT TO HEATED STRUCTURE</del>
R403.3.1	Delete
R403.3.1.1	Delete
R403.3.4	Delete
Figures and tables	Delete all page 80 IRC 2009 Delete all page 81 IRC 2009 Delete all page 82 IRC 2009 Delete all page 83 IRC 2009 Delete all page 84 IRC 2009
R404.1.4	Delete

Seismic Design category D0, D1,D2	
R404.1.4.1 Masonry foundation walls	<b>Delete</b>
R404.1.4.2 Concrete foundation walls	<b>Delete</b>
Figure R404.1.5 (1)	<del><b>FIGURE R404.1.5(1) FOUNDATION WALL CLAY MASONRY CURTAIN WALL WITH CONCRETE MASONRY PIPES</b></del>
R404.1.5.3 Pier and curtain walls	<p><u>Curtain walls 4 inch (nominal) minimum thickness between piers and bonded into piers supported on concrete footings poured integrally with pier footings may be used for frame construction and for masonry veneer frame construction not more than 2 stories in height subject to the following limitations:</u></p> <p><del>Pier and curtain wall foundations shall be permitted to be used to support light-frame construction not more than two stories in height, provided the following requirements are met:</del></p> <ol style="list-style-type: none"> <li>1. All load-bearing walls shall be placed on continuous concrete footings placed integrally with the exterior wall footings.</li> <li>2. The minimum actual thickness of a load-bearing masonry wall shall be not less than 4 inches (102 mm) nominal or 3 3/8 inches (92 mm) actual thickness, and shall be bonded integrally with piers spaced in accordance with Section R606.8.</li> <li>3. Piers shall be constructed in accordance with Section R606.5 and Section R606.5.1, and shall be bonded into the load-bearing masonry wall in accordance with Section R608.1.1 or Section R608.1.1.2.</li> <li>4. The maximum height of a 4-inch (102 mm) load-bearing masonry foundation wall supporting wood framed walls and floors shall not be more than <u>6 feet (1829 mm)</u> <del>4 feet (1219 mm)</del> in height.</li> <li>5. Anchorage shall be in accordance with R403.1.6, Figure R404.1.5(1), or as specified by engineered design accepted by the building official.</li> <li>6. The unbalanced fill for 4-inch (102 mm) foundation walls shall not exceed 24 inches (610 mm) for solid masonry or <u>16 inches (406 mm)</u> <del>12 inches (305 mm)</del> for hollow masonry.</li> <li>7. <u>Pier size shall be based on Table 403.1(a).</u> <del>In Seismic Design Categories D1 and D2 prescriptive reinforcement shall be provided in the horizontal and vertical directions. Provide minimum horizontal joint reinforcement of two No. 9 gage wires spaced not less than 6 inches (152 mm) or one 1/4 inch (6.4 mm) diameter wire at 10 inches (254 mm) on center vertically. Provide minimum vertical reinforcement of one #4 bar at 48 inches (1220 mm) on center horizontally grouted in place.</del></li> <li>8. <u>See Chapter 45 for special anchorage and reinforcement in high wind zones.</u></li> </ol>
R404.1.5.4 Piers	<p><u>The unsupported height of masonry piers shall not exceed 10 times their least dimension. When structural clay tile or hollow concrete masonry units are used for isolated piers to support beams and girders, the cellular spaces shall be filled solidly with concrete or Type M or S mortar, except that unfilled hollow piers may be used if their unsupported height is not more than four times their least dimension. When hollow masonry units are solidly filled with concrete or Type M or S mortar, the allowable compressive stress may be increased as provided in Table 606.5.</u></p>

<b>R404.4 Retaining walls</b>	<p>Retaining walls that are not laterally supported at the top and that retain in excess of <u>48"</u> of unbalanced fill shall be designed to ensure stability against overturning, sliding, excessive foundation pressure and water uplift. In addition any retaining wall which meets the following:</p> <ol style="list-style-type: none"> <li>1. <u>Any retaining wall systems on a residential site that cross over adjacent property lines regardless of vertical height, and</u></li> <li>2. <u>Retaining walls that support buildings and their accessory structures.</u></li> </ol> <p>Retaining walls shall be designed for a safety factor of 1.5 against lateral sliding and overturning.</p>
<b>R405.1.1 Precast concrete foundation</b>	<p>Copy from 2009IRC and removed "into a approved sewer system"</p>
<b>R405.2.3 Drainage system</b>	<p>Copy from 2009IRC and removed "into a approved sewer system"</p>
<b>R406.1 Concrete and masonry foundation damp proofing</b>	<p><u>406.1 Concrete and masonry foundation dampproofing. Foundation walls where the outside grade is higher than the inside grade shall be dampproofed from the top of the footing to the finished grade. Masonry walls shall have not less than 3/8 inch (9.5 mm) portland cement parging applied to the exterior of the wall. The foundation walls shall be darnproofed with a bituminous coating 3 pounds per square yard (1 63 kg/m <i>z.l.cl</i> acrylic modified cement 1/8-inch (3.2 mm) coat of surface bonding mortar complying with ASTM C 887 or any material permitted for waterproofing in Section R406.2. Concrete walls shall be dampproofed by applying anyone of the above listed darnproofing materials or anyone of the waterproofing materials listed in Section R406. 2 to the exterior of the wall</u></p>
<b>R407.3 Structural requirements</b>	<p>The columns shall be restrained to prevent lateral displacement at the <u>top</u> and <u>bottom</u> ends. Wood columns shall not be less in nominal size than 4 inches by 4 inches (102 mm by 102 mm) and steel columns shall not be less than 3-inch-diameter (76 mm) standard pipe or approved equivalent.</p> <p>Exception: In Seismic Design Categories A, Band C columns no more than 48 inches (1219 mm) in height on a pier or footing are exempt from the bottom end lateral displacement requirement within underfloor areas enclosed by a continuous foundation.</p>
<b>Section R408</b>	<p><b>Remove all of IRC section R408 and add NC</b></p>
<b>R408.1 Space moisture vapor control</b>	<p><u>Vented crawl space foundations shall be provided with foundation vent openings through the exterior foundation walls.</u></p>
<b>R408.1.1 Foundation vent sizing</b>	<p><u>The minimum net area of ventilation openings shall be not less than 1 square foot (0.0929 m<sup>2</sup>) for each 150 square feet (13.9 m<sup>2</sup>) of crawl space ground area.</u></p> <p><u><b>Exception:</b> The total area of ventilation openings may be reduced to 1/1,500 of the crawl space ground area where the required openings are placed so as provide cross-ventilation of the crawl space. The installation of operable louvers shall not be prohibited.</u></p>
<b>R408.1.2 Foundation vent location</b>	<p><u>One foundation vent shall be within 3 feet (914mm) of each corner of the building. To prevent rainwater entry when the crawlspace is built on a sloped site, the uphill foundation walls may be constructed without wall vent openings. Vent dams shall be provided when the bottom of the foundation vent opening is less than 4 inches above the finished exterior grade.</u></p>

<b>R408.1.3 Covering material</b>	<p><u>To prevent rodent entry, foundation vents shall be covered with any of the following materials provided that the ventilation holes through the covering material shall not exceed ¼ inch (6.4 mm) in any direction:</u></p> <ol style="list-style-type: none"> <li>1. <u>Perforated sheet metal plates not less than 0.070 inch (1.8 mm) thick.</u></li> <li>2. <u>Expanded sheet metal plates no less than 0.047 inch (1.2 mm) thick.</u></li> <li>3. <u>Cast iron grills or grating.</u></li> <li>4. <u>Extruded load-bearing brick vents.</u></li> <li>5. <u>Hardware cloth of 0.035 inch (0.89 mm) wire or heavier.</u></li> <li>6. <u>Corrosion-resistant mesh, with the least dimension being 1/8 inch (3.2 mm).</u></li> </ol>
<b>R408.1.4 Drains and vent terminations</b>	<p><u>Drains (including but not limited to pressure relief and drain pans) shall terminate outdoors, to crawl space floor drains or interior pumps, and shall not intentionally discharge water into the crawl space. Crawl space drains shall be separate from roof gutter drain systems and foundation perimeter drains. Dryer vents shall terminate outdoors.</u></p>
<b>R408.1.5 Space separation</b>	<p><u>Wall vented crawl spaces shall be separated from adjoining basements, porches and garages by permanent solid wall surfaces with all utility penetrations thru the separating wall sealed. Latched, weather-stripped doors or access panels shall provide access between the crawl space and such adjoining spaces.</u></p>
<b>R408.2 Ground vapor retarder</b>	<p><u>Requires full coverage ground vapor retarders for all wall vented ground spaces. Wall vented crawl spaces shall be protected from water entry by the evaporation of water from the ground surface. A minimum 6-mil (0.15 mm) polyethylene vapor retarder or equivalent shall be installed to nominally cover all exposed earth in the crawl space, with joints lapped not less than 12 inches. Where there is no evidence that the groundwater table can rise to within 6 inches (152 mm) of the floor of the crawl space, it is acceptable to puncture the ground vapor retarder at low spots to prevent water puddles from forming on top of the vapor retarder due to condensation. The floor of the crawl space shall be graded so that it drains to one or more low spots. Install a drain to daylight or sump pump at each low spot. Crawl space drains shall be kept separate from roof gutter drain systems and foundation perimeter drains.</u></p>
<b>R408.3 Wall damp proofing</b>	<p><u>Where the outside grade is higher than the inside grade the exterior walls shall be dampproofed from the top of the footing to the finished grade as required by R406.1.</u></p>
<b>R408.4 Site grading</b>	<p><u>Building site shall be graded to drain water away from the crawl space foundation per the requirements of R401.3.</u></p>
<b>R408.5 Insulation</b>	<p><u>The thermal insulation in a wall vented crawl space shall be placed in the floor system. Wall insulation is not allowed as the only insulation system in a wall vented crawl space. The required insulation value can be determined from Table N1102.1.</u></p>

<b>R408.6 Floor air leakage control</b>	<u>All plumbing, electrical, duct, plenum, phone, cable, computer wiring and other penetrations through the subfloor shall be sealed with non-porous materials, caulks, or sealants. The use of Rockwool or fiberglass insulation is prohibited as an air sealant.</u>
<b>R408.7 Duct air leakage control</b>	<u>All heating and cooling ductwork located in the crawl space shall be sealed with mastic or other industry approved duct closure systems.</u>
<b>R408.8 Access</b>	<u>A minimum access opening measuring 18 inches by 24 inches (457 mm by 610 mm) shall be provided to the crawl space. See the North Carolina Mechanical Code for access requirements where mechanical equipment is located under floors.</u>
<b>R408.9 Removal of debris</b>	<u>The crawl space floor shall be cleaned of all vegetation and organic material. All wood forms used for placing shall be removed before the building is occupied or used for any purpose. All construction materials shall be removed before the building is occupied or used for any purpose.</u>
<b>R408.10 Finished grade</b>	<u>The finished grade of the crawl space may be located at the bottom of the footings; however, where there is evidence that the groundwater table can rise to within 6 inches (152 mm) of the finished grade of the crawl space at the perimeter or where there is evidence that the surface water does not readily drain from the building site, the grade in the crawl space shall be as high as the outside finished grade, unless an approved drainage system is provided.</u>
<b>R408.11 Flood resistance</b>	<u>For buildings located in areas prone to flooding as established in Table R301.2 (1), the walls enclosing the crawl space shall be provided with flood openings in accordance with Section R323.2.2.</u>
<b>R409</b>	<u>Closed crawl spaces</u>
<b>R409.1 Air sealed walls</b>	<u>Closed crawl spaces shall be built to minimize the entry of outdoor air into the crawl space. Specifically prohibited are foundation wall vents and wall openings to ventilated porch foundations. When outdoor packaged heating and cooling equipment is used, solid blocking and sealants shall be used to seal gaps between the exterior wall opening and the smaller supply and return ducts that pass through the opening.</u>
<b>R409.1.1 Caulking and sealants</b>	<u>Air sealing caulk, gaskets or sealants shall be applied to the foundation wall and floor assemblies that separate the crawl space from outside and other ventilated areas such as joints around access door and frame, between foundation and sill plate, at penetrations for plumbing, mechanical, electrical and gas lines and at duct penetrations.</u>
<b>R409.1.2 Access panel/door</b>	<u>A minimum access opening measuring 18 inches by 24 inches (457 mm by 610 mm) shall be provided to the crawl space. See the North Carolina Mechanical Code for access requirements where mechanical equipment is located under floors. To minimize air entry, provide a tight fitting access panel/door with a latch mechanism. Access panels or doors shall be insulated to a minimum of R-2.</u>
<b>R409.2 Groundwater vapor retarder</b>	<u>Closed crawl spaces shall be protected from water entry by the evaporation of water from the ground</u>

	<u>surface.</u>
<b>R409.2.1 Ground vapor retarder</b>	<u>A minimum 6-mil (0.15 mm) polyethylene vapor retarder or equivalent shall be installed to nominally cover all exposed earth in the crawl space, with joints lapped not less than 12 inches. Minor pockets or wrinkles that prevent total drainage across the surface of the vapor retarder are allowed. The floor of the crawl space shall be graded so that it drains to one or more low spots. Install a drain to daylight or sump pump at each low spot. Crawl space drains shall be kept separate from roof gutter drain systems and foundation perimeter drains.</u>
<b>R409.2.2 Liner</b>	<u>The ground vapor retarder may be installed as a full interior liner by sealing the edges to the walls and beam columns and sealing the seams. Single piece liner systems are approved. The top edge of the wall liner shall terminate 3 inches below the top edge of the masonry foundation wall. The top edge of the liner shall be brought up the interior columns a minimum of 4 inches above the crawl space floor. The floor of the crawl space shall be graded so that it drains to one or more low spots. Install a drain to daylight or sump pump at each low spot. Crawl space drains shall be separate from roof gutter drain systems and foundation perimeter drains.</u>
<b>R409.2.2.1 Wall liner termite inspection gap</b>	<u>Provide a clear and unobstructed 3" minimum inspection gap between the top of the wall liner and the bottom of the wood sill. This inspection gap may be ignored with regards to energy performance and is not intended to create an energy penalty.</u>
<b>R409.2.3 Concrete floor surfacing</b>	<u>The ground vapor retarder may be protected against ripping and displacement by pouring an unreinforced, minimum 2-inch thick, concrete surface directly over the vapor barrier. A base course of gravel or other drainage material under the ground moisture barrier is not required. The floor of the crawl space shall be graded so that the concrete surface drains to one or more low spots. Install a drain to daylight or sump pump at each low spot. Crawl space drains shall be separate from roof gutter drain systems and foundation perimeter drains.</u>
<b>R409.2.4 Drains and vent terminations</b>	<u>Drains (including but not limited to pressure relief and drain pans) shall terminate outdoors, to crawl space floor drains or interior pumps, and shall not intentionally discharge water into the crawl space. Crawl space drains shall be separate from roof gutter drain systems and foundation perimeter drains. Dryer vents shall terminate outdoors.</u>
<b>R409.3 Wall damp proofing</b>	<u>Where the outside grade is higher than the inside grade the exterior walls shall be dampproofed from the top of the footing to the finished grade as required by R406.1.</u>
<b>R409.4 Site grading</b>	<u>Building site shall be graded to drain water away from the crawl space foundation per the requirements of R401.3.</u>
<b>R409.5 Space moisture vapor control</b>	<u>Closed crawl spaces shall be provided with a mechanical drying capability to control space moisture levels. The allowed methods are listed below in R409.5.1 – R409.5.5. At least one method shall be provided; however, combination systems shall be allowed.</u>
<b>R409.5.1 Dehumidifier</b>	<u>A permanently installed dehumidifier shall be provided in the crawl space. The minimum rated capacity per day is 15 pints (7.1 Liters). Condensate discharge shall be drained to daylight or interior</u>





	<u>condensate pump. Permanently installed dehumidifier shall be provided with an electrical outlet.</u>
<b>R409.5.2 Supply air</b>	<u>Supply air from the dwelling air conditioning system shall be ducted into the crawl space at the rate of 1 cubic foot per minute (0.5 L/s) per 30 square feet (4.6 m<sup>2</sup>) of crawl space floor area. No return air duct from the crawl space to the dwelling air conditioning system is allowed. The crawl space supply air duct shall be fitted with a backflow damper to prevent the entry of crawl space air into the supply duct system when the system fan is not operating. An air relief vent to the outdoors may be installed. Crawl spaces with moisture vapor control installed in accordance with this section are not considered plenums.</u>
<b>R409.5.3 House air</b>	<u>House air shall be blown into the crawl space with a fan at the rate of 1 cubic foot per minute (0.5 L/s) per 50 square feet (4.6 m<sup>2</sup>) of crawl space floor area. The fan motor shall be rated for continuous duty. No return air duct from the crawl space to the dwelling air conditioning system is allowed. An air relief vent to the outdoors may be installed. Crawl spaces with moisture vapor control installed in accordance with this section are not considered plenums.</u>
<b>R409.5.4 Exhaust fan</b>	<u>Crawl space air shall be exhausted to outside with a fan at the rate of 1 cubic foot per minute (0.5 L/s) per 50 square feet (4.6 m<sup>2</sup>) of crawl space floor area. The fan motor shall be rated for continuous duty. There is no requirement for make-up air.</u>
<b>R409.6 Plenums</b>	<u>Closed crawl spaces used as supply or return plenums for distribution of heated or cooled air shall comply with the requirements of the NC Mechanical Code. Crawl space plenums shall not contain plumbing cleanouts, gas lines or other prohibited components. Foam plastic insulation located in a crawl space plenum shall be protected against ignition by an approved thermal barrier.</u>
<b>R409.7 Combustion air</b>	<u>The air sealing requirements of a closed crawl space may result in a foundation which can not provide adequate combustion air for fuel-burning appliances; therefore, fuel-burning appliances located in the crawl space such as furnaces and water heaters shall obtain combustion air from outdoors as per the NC Mechanical Code.</u>
<b>R409.8 Insulation</b>	<u>The thermal insulation in a crawl space may be located in the floor system or at the exterior walls. The required insulation value can be determined from Table N1102.1.</u>  <b><u>Exception:</u></b> <u>Insulation shall be placed at the walls when the following condition exists:</u>  <ol style="list-style-type: none"><li><u>The closed crawl space is designed to be intentionally heated or cooled, conditioned space.</u></li></ol>
<b>R409.8.1 Wall insulation</b>	<u>Where the floor above a crawl space is not insulated, the walls shall be insulated. Wall insulation can be located on any combination of the exterior and interior surfaces and within the structural cavities or materials of the exterior crawl space walls. Wall insulation systems require that the band joist area of the floor frame be insulated. Wall insulation shall begin 3 inches below the top of the masonry foundation wall and shall extend down to 3 inches above the top of the footing or concrete floor, 3 inches above the interior ground surface or 24-inches below the outside finished ground level, whichever is less. No insulation shall be required on masonry walls of 9 inches height or less.</u>
<b>R409.8.1.1 Foam plastic termite inspection gap</b>	<u>For outside wall Section R324 governs applications. When expanded polystyrene, polyisocyanurate, or other foam plastic insulation is installed on the inside surface of the exterior foundation walls, provisions R409.8.1.1.1 – 2 below apply.</u>

<b>R409.8.1.1.1 Earth floored crawl spaces</b>	<p><u>Provide a clear and unobstructed 3-inch minimum termite inspection gap between the top of the foam plastic wall insulation and the bottom of the wood sill. Because insulation ground contact is not allowed, provide a continuous 3-inch minimum clearance gap between the bottom edge of the foam plastic wall insulation and the earth floor surface. Refer to N1102.1.7 to determine maximum allowances for insulation gaps.</u></p>
<b>R409.8.1.1.2 Concrete floor surfaced crawl spaces</b>	<p><u>Provide a clear and unobstructed 3-inch minimum termite inspection gap between the top of the foam plastic wall insulation and the bottom of the wood sill. Provide a continuous 3-inch minimum clearance gap between the bottom edge of the foam plastic wall insulation and the earth floor surface. Refer to N1102.1.7 to determine maximum allowances for insulation gaps.</u></p>
<b>R409.8.1.2 Porous insulation material</b>	<p><u>When fiberglass, rockwool, cellulose or other porous insulation materials are installed on the inside wall surface of a closed crawl space, provide a clear and unobstructed 3-inch minimum termite inspection gap between the top of the porous wall insulation and the bottom of the wood sill.</u></p> <p><u>To reduce wicking potential, porous insulation ground contact is not allowed in earth floored or concrete surfaces crawl spaces. Provide a continuous 3-inch minimum wicking gap between the bottom edge of the porous wall insulation and the earth or concrete floor surface. Refer to N1102.1.7 to determine maximum allowances for insulation gaps.</u></p>
<b>R409.8.2 Foam plastic fire safety</b>	<p><u>Foam plastic insulation may be intalled inside crawl spaces without a thermal cover when the insulation product has been tested in accordance with ASTM E 84 to have a flame-spread rating of not more than 25 and a smoke developed rating of not more than 450. Foam plastics that have not been tested to meet these ratings shall be protected against ignition by covering them with a thermal barrier. Acceptable thermal barriers include but are not limited to 1/2 inch cement board, metal foil sheets, metal foil tape, steel or aluminum metal sheets or other approved materials installed in such a manner that the foam is not exposed.</u></p> <p><u><b>Exception:</b> Foam plastic insulation located in closed crawl spaces used as conditioned spaces or plenums shall be protected against ignition by an approved thermal barrier.</u></p>
<b>R409.9 Floor air leakage control</b>	<p><u>All plumbing, electrical, duct, plenum, phone, cable, computer wiring and other penetrations through the subfloor shall be sealed with non-porous materials, caulks, or sealants. The use of Rockwool or fiberglass insulation is prohibited as an air sealant.</u></p>
<b>R409.10 Duct air leakage control</b>	<p><u>All heating and cooling ductwork located in the crawl space shall be sealed with mastic or other industry approved duct closure systems.</u></p>
<b>R409.11 Access</b>	<p><u>A minimum access opening measuring 18 inches by 24 inches (457 mm by 610 mm) shall be provided to the crawl space. See the North Carolina Mechanical Code for access requirements where mechanical equipment is located under floors.</u></p>
<b>R409.12 Removal of debris</b>	<p><u>The crawl space floor shall be cleaned of all vegetation and organic material. All wood forms used for placing shall be removed before the building is occupied or used for any purpose. All construction materials shall be removed before the building is occupied or used for any purpose.</u></p>

<b>R409.13 Finished grade</b>	<p><u>The finished grade of the crawl space may be located at the bottom of the footings; however, where there is evidence that the groundwater table can rise to within 6 inches (152 mm) of the finished grade of the crawl space at the perimeter or where there is evidence that the surface water does not readily drain from the building site, the grade in the crawl space shall be as high as the outside finished grade, unless an approved drainage system is provided.</u></p>
<h2>Chapter 5 Floors</h2>	
<b>R502.2.1 Decks</b>	<p>Where supported by attachment to an exterior wall, decks shall be positively anchored to the primary structure and designed for both vertical and lateral loads as applicable. Such attachment shall not be accomplished by the use of toenails or nails subject to withdrawal. Where positive connection to the primary building structure cannot be verified during inspection, decks shall be self-supporting. For decks with cantilevered framing members, connections to exterior walls or other framing members, shall be designed and constructed to resist uplift resulting from the full live load specified in Table <u>R301.5</u> acting on the cantilevered portion of the deck. <u>Exterior decks shall be permitted to be constructed in accordance with Appendix M.</u></p>
<b>R502.2.2.1</b>	<p><b>Delete</b></p>
<b>R502.2.2.1.1</b>	<p><b>Delete</b></p>
<b>R502.2.2.2</b>	<p><b>Delete</b></p>
<b>R502.2.2.3</b>	<p><b>Delete</b></p>
<b>R502.2.2.4</b>	<p><b>Delete</b></p>
<b>Table R502.2.1</b>	<p><b>Delete</b></p>
<b>Figure 502.2.2.3</b>	<p><b>Delete</b></p>
<b>Table R502.3.3 (1)</b>	<p>Use IRC table but keep NC footnote g:</p> <p style="text-align: center;"><b>g. A full-depth rim joist shall be provided at the cantilevered end of the joists. Solid blocking shall be provided at the cantilever support.</b></p>
<b>Tables R502.5 (1) &amp; R502.5 (2)</b>	<p>Use IRC tables R502.5 (1) &amp; (2) but add New illustrations</p>

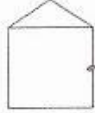
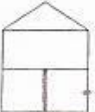
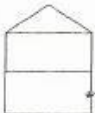
**GIRDER SPANS\* AND HEADER SPANS\* FOR EXTERIOR BEARING WALLS**  
 (Maximum spans for Douglas fir-larch, hem-fir, southern pine and spruce-pine-fir<sup>b</sup> and required number of jack studs)

GIRDERS AND HEADERS SUPPORTING	SIZE	GROUND SNOW LOAD (psf) <sup>c</sup>																	
		30						50						70					
		Building width <sup>e</sup> (feet)																	
		20		28		36		20		28		36		20		28		36	
Span	NJ <sup>d</sup>	Span	NJ <sup>d</sup>	Span	NJ <sup>d</sup>	Span	NJ <sup>d</sup>	Span	NJ <sup>d</sup>	Span	NJ <sup>d</sup>	Span	NJ <sup>d</sup>	Span	NJ <sup>d</sup>	Span	NJ <sup>d</sup>		
Roof and ceiling 	2-2x4	3-6	1	3-2	1	2-10	1	3-2	1	2-9	1	2-6	1	2-10	1	2-6	1	2-3	1
	2-2x6	5-5	1	4-8	1	4-2	1	4-8	1	4-1	1	3-8	2	4-2	1	3-8	2	3-3	2
	2-2x8	6-10	1	5-11	2	5-4	2	5-11	2	5-2	2	4-7	2	5-4	2	4-7	2	4-1	2
	2-2x10	8-5	2	7-3	2	6-6	2	7-3	2	6-3	2	5-7	2	6-6	2	5-7	2	5-0	2
	2-2x12	9-9	2	8-5	2	7-6	2	8-5	2	7-3	2	6-6	2	7-6	2	6-6	2	5-10	3
	3-2x8	8-4	1	7-5	1	6-8	1	7-5	1	6-5	2	5-9	2	6-8	1	5-9	2	5-2	2
	3-2x10	10-6	1	9-1	2	8-2	2	9-1	2	7-10	2	7-0	2	8-2	2	7-0	2	6-4	2
	3-2x12	12-2	2	10-7	2	9-5	2	10-7	2	9-2	2	8-2	2	9-5	2	8-2	2	7-4	2
	4-2x8	9-2	1	8-4	1	7-8	1	8-4	1	7-5	1	6-8	1	7-8	1	6-8	1	5-11	2
	4-2x10	11-8	1	10-6	1	9-5	2	10-6	1	9-1	2	8-2	2	9-5	2	8-2	2	7-3	2
	4-2x12	14-1	1	12-2	2	10-11	2	12-2	2	10-7	2	9-5	2	10-11	2	9-5	2	8-5	2
	Roof, ceiling and one center-bearing floor 	2-2x4	3-1	1	2-9	1	2-5	1	2-9	1	2-5	1	2-2	1	2-7	1	2-3	1	2-0
2-2x6		4-6	1	4-0	1	3-7	2	4-1	1	3-7	2	3-3	2	3-9	2	3-3	2	2-11	2
2-2x8		5-9	2	5-0	2	4-6	2	5-2	2	4-6	2	4-1	2	4-9	2	4-2	2	3-9	2
2-2x10		7-0	2	6-2	2	5-6	2	6-4	2	5-6	2	5-0	2	5-9	2	5-1	2	4-7	3
2-2x12		8-1	2	7-1	2	6-5	2	7-4	2	6-5	2	5-9	3	6-8	2	5-10	3	5-3	3
3-2x8		7-2	1	6-3	2	5-8	2	6-5	2	5-8	2	5-1	2	5-11	2	5-2	2	4-8	2
3-2x10		8-9	2	7-8	2	6-11	2	7-11	2	6-11	2	6-3	2	7-3	2	6-4	2	5-8	2
3-2x12		10-2	2	8-11	2	8-0	2	9-2	2	8-0	2	7-3	2	8-5	2	7-4	2	6-7	2
4-2x8		8-1	1	7-3	1	6-7	1	7-5	1	6-6	1	5-11	2	6-10	1	6-0	2	5-5	2
4-2x10		10-1	1	8-10	2	8-0	2	9-1	2	8-0	2	7-2	2	8-4	2	7-4	2	6-7	2
4-2x12		11-9	2	10-3	2	9-3	2	10-7	2	9-3	2	8-4	2	9-8	2	8-6	2	7-7	2
Roof, ceiling and one clear span floor 		2-2x4	2-8	1	2-4	1	2-1	1	2-7	1	2-3	1	2-0	1	2-5	1	2-1	1	1-10
	2-2x6	3-11	1	3-5	2	3-0	2	3-10	2	3-4	2	3-0	2	3-6	2	3-1	2	2-9	2
	2-2x8	5-0	2	4-4	2	3-10	2	4-10	2	4-2	2	3-9	2	4-6	2	3-11	2	3-6	2
	2-2x10	6-1	2	5-3	2	4-8	2	5-11	2	5-1	2	4-7	3	5-6	2	4-9	2	4-3	3
	2-2x12	7-1	2	6-1	3	5-5	3	6-10	2	5-11	3	5-4	3	6-4	2	5-6	3	5-0	3
	3-2x8	6-3	2	5-5	2	4-10	2	6-1	2	5-3	2	4-8	2	5-7	2	4-11	2	4-5	2
	3-2x10	7-7	2	6-7	2	5-11	2	7-5	2	6-5	2	5-9	2	6-10	2	6-0	2	5-4	2
	3-2x12	8-10	2	7-8	2	6-10	2	8-7	2	7-5	2	6-8	2	7-11	2	6-11	2	6-3	2
	4-2x8	7-2	1	6-3	2	5-7	2	7-0	1	6-1	2	5-5	2	6-6	1	5-8	2	5-1	2
	4-2x10	8-9	2	7-7	2	6-10	2	8-7	2	7-5	2	6-7	2	7-11	2	6-11	2	6-2	2
	4-2x12	10-2	2	8-10	2	7-11	2	9-11	2	8-7	2	7-8	2	9-2	2	8-0	2	7-2	2
	Roof, ceiling and two center-bearing floors 	2-2x4	2-7	1	2-3	1	2-0	1	2-6	1	2-2	1	1-11	1	2-4	1	2-0	1	1-9
2-2x6		3-9	2	3-3	2	2-11	2	3-8	2	3-2	2	2-10	2	3-5	2	3-0	2	2-8	2
2-2x8		4-9	2	4-2	2	3-9	2	4-7	2	4-0	2	3-8	2	4-4	2	3-9	2	3-5	2
2-2x10		5-9	2	5-1	2	4-7	3	5-8	2	4-11	2	4-5	3	5-3	2	4-7	3	4-2	3
2-2x12		6-8	2	5-10	3	5-3	3	6-6	2	5-9	3	5-2	3	6-1	3	5-4	3	4-10	3
3-2x8		5-11	2	5-2	2	4-8	2	5-9	2	5-1	2	4-7	2	5-5	2	4-9	2	4-3	2
3-2x10		7-3	2	6-4	2	5-8	2	7-1	2	6-2	2	5-7	2	6-7	2	5-9	2	5-3	2
3-2x12		8-5	2	7-4	2	6-7	2	8-2	2	7-2	2	6-5	3	7-8	2	6-9	2	6-1	3
4-2x8		6-10	1	6-0	2	5-5	2	6-8	1	5-10	2	5-3	2	6-3	2	5-6	2	4-11	2
4-2x10		8-4	2	7-4	2	6-7	2	8-2	2	7-2	2	6-5	2	7-7	2	6-8	2	6-0	2
4-2x12		9-8	2	8-6	2	7-8	2	9-5	2	8-3	2	7-5	2	8-10	2	7-9	2	7-0	2

(continued)

**TABLE R502.5(1)—continued**  
**GIRDER SPANS\* AND HEADER SPANS\* FOR EXTERIOR BEARING WALLS**  
 (Maximum spans for Douglas fir-larch, hem-fir, southern pine and spruce-pine-fir<sup>b</sup> and required number of jack studs)

GIRDERS AND HEADERS SUPPORTING	SIZE	GROUND SNOW LOAD (psf) <sup>a</sup>																	
		30						50						70					
		Building width <sup>c</sup> (feet)																	
		20		28		36		20		28		36		20		28		36	
Span	NJ <sup>d</sup>	Span	NJ <sup>d</sup>	Span	NJ <sup>d</sup>	Span	NJ <sup>d</sup>	Span	NJ <sup>d</sup>	Span	NJ <sup>d</sup>	Span	NJ <sup>d</sup>	Span	NJ <sup>d</sup>	Span	NJ <sup>d</sup>		
Roof, ceiling and two clear span floor 	2-2x4	2-1	1	1-8	1	1-6	2	2-0	1	1-8	1	1-5	2	2-0	1	1-8	1	1-5	2
	2-2x6	3-1	2	2-8	2	2-4	2	3-0	2	2-7	2	2-3	2	2-11	2	2-7	2	2-3	2
	2-2x8	3-10	2	3-4	2	3-0	3	3-10	2	3-4	2	2-11	3	3-9	2	3-3	2	2-11	3
	2-2x10	4-9	2	4-1	3	3-8	3	4-8	2	4-0	3	3-7	3	4-7	3	4-0	3	3-6	3
	2-2x12	5-6	3	4-9	3	4-3	3	5-5	3	4-8	3	4-2	3	5-4	3	4-7	3	4-1	4
	3-2x8	4-10	2	4-2	2	3-9	2	4-9	2	4-1	2	3-8	2	4-8	2	4-1	2	3-8	2
	3-2x10	5-11	2	5-1	2	4-7	3	5-10	2	5-0	2	4-6	3	5-9	2	4-11	2	4-5	3
	3-2x12	6-10	2	5-11	3	5-4	3	6-9	2	5-10	3	5-3	3	6-8	2	5-9	3	5-2	3
	4-2x8	5-7	2	4-10	2	4-4	2	5-6	2	4-9	2	4-3	2	5-5	2	4-8	2	4-2	2
	4-2x10	6-10	2	5-11	2	5-3	2	6-9	2	5-10	2	5-2	2	6-7	2	5-9	2	5-1	2
	4-2x12	7-11	2	6-10	2	6-2	3	7-9	2	6-9	2	6-0	3	7-8	2	6-8	2	5-11	3

For SI: 1 inch = 25.4 mm, 1 pound per square foot = 0.0479 kPa.

a. Spans are given in feet and inches.



b. Tabulated values assume #2 grade lumber.

c. Building width is measured perpendicular to the ridge. For widths between those shown, spans are permitted to be interpolated.

d. NJ - Number of jack studs required to support each end. Where the number of required jack studs equals one, the header is permitted to be supported by an approved framing anchor attached to the full-height wall stud and to the header.

e. Use 30 psf ground snow load for cases in which ground snow load is less than 30 psf and the roof live load is equal to or less than 20 psf.

**GIRDER SPANS\* AND HEADER SPANS\* FOR INTERIOR BEARING WALLS**  
 (Maximum spans for Douglas fir-larch, hem-fir, southern pine and spruce-pine-fir<sup>b</sup> and required number of jack studs)

HEADERS AND GIRDERS SUPPORTING	SIZE	BUILDING WIDTH <sup>c</sup> (feet)					
		20		28		36	
		Span	NJ <sup>d</sup>	Span	NJ <sup>d</sup>	Span	NJ <sup>d</sup>
One floor only 	2-2x4	3-1	1	2-8	1	2-5	1
	2-2x6	4-6	1	3-11	1	3-6	1
	2-2x8	5-9	1	5-0	2	4-5	2
	2-2x10	7-0	2	6-1	2	5-5	2
	2-2x12	8-1	2	7-0	2	6-3	2
	3-2x8	7-2	1	6-3	1	5-7	2
	3-2x10	8-9	1	7-7	2	6-9	2
	3-2x12	10-2	2	8-10	2	7-10	2
	4-2x8	9-0	1	7-8	1	6-9	1
	4-2x10	10-1	1	8-9	1	7-10	2
4-2x12	11-9	1	10-2	2	9-1	2	
Two floors 	2-2x4	2-2	1	1-10	1	1-7	1
	2-2x6	3-2	2	2-9	2	2-5	2
	2-2x8	4-1	2	3-6	2	3-2	2
	2-2x10	4-11	2	4-3	2	3-10	3
	2-2x12	5-9	2	5-0	3	4-5	3
	3-2x8	5-1	2	4-5	2	3-11	2
	3-2x10	6-2	2	5-4	2	4-10	2
	3-2x12	7-2	2	6-3	2	5-7	3
	4-2x8	6-1	1	5-3	2	4-8	2
	4-2x10	7-2	2	6-2	2	5-6	2
4-2x12	8-4	2	7-2	2	6-5	2	

For SI: 1 inch = 25.4 mm, 1 foot = 304.8 mm.

a. Spans are given in feet and inches.

b. Tabulated values assume #2 grade lumber.

c. Building width is measured perpendicular to the ridge. For widths between those shown, spans are permitted to be interpolated.

d. NJ - Number of jack studs required to support each end. Where the number of required jack studs equals one, the header is permitted to be supported by an approved framing anchor attached to the full-height wall stud and to the header.

**Figure 502.8  
& 502.8a**

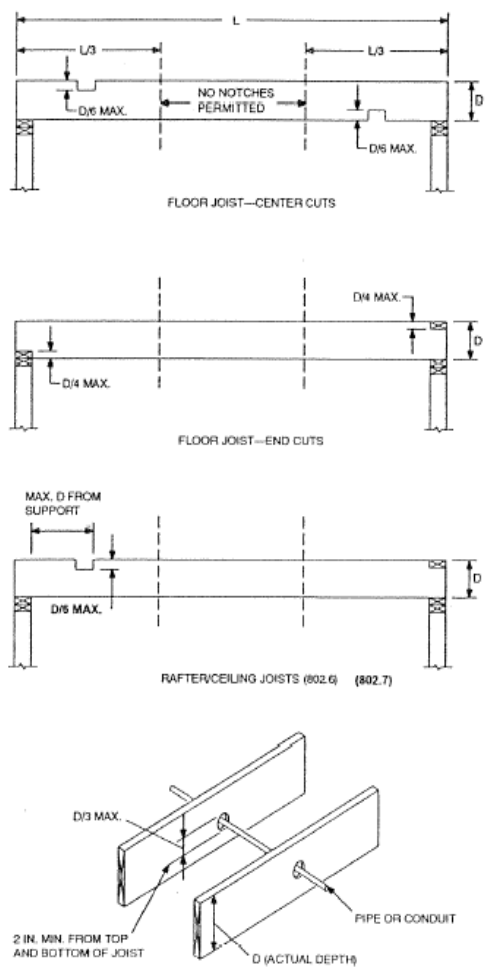

**FIGURE R 502.8  
CUTTING, NOTCHING AND DRILLING**

1. Do not drill in center 2/10's of joist span.
2. Do not drill directly under load bearing walls at ends.
3. Do not drill closer than 2" to top or bottom edge.
4. Apply 4'-0" joist width x 1/2" CDX plywood with face grain running with joist to both sides using 6d nails or 1-1/2" screws 1" from top and bottom 4" o.c.

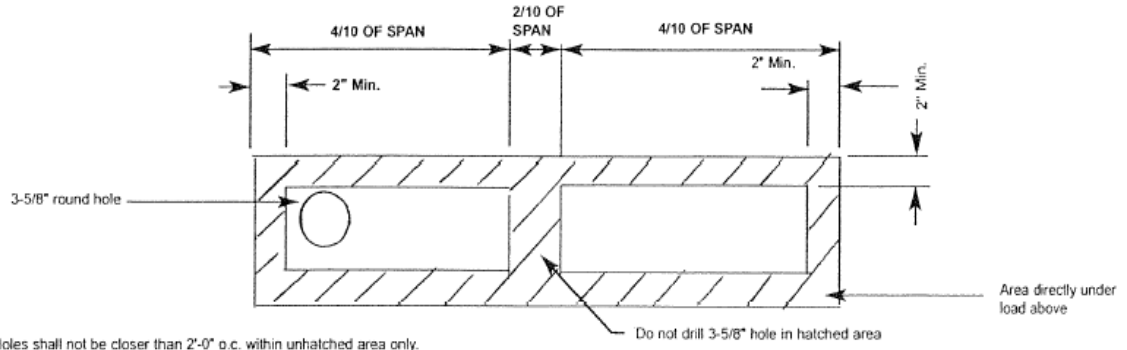

5. Holes shall not be closer than 2'-0" o.c. within unhatched area only.
6. Plywood shall be attached such that 2" minimum of plywood is on each side of the hole location, except when the hole is located within 2 feet of end of joist.

**FIGURE R502.8a  
ACCEPTABLE LOCATION OF 3 5/8" DIAMETER HOLE IN 2 X 10 JOIST**

**Table  
R503.2.1.1 (1)**

**Accept table R503.2.1 (1) but include in first column span rating with (Roof/Floor) underneath. Also change printing error next to 48/24 span rating should show 3/4" instead of 3/48.**

# Chapter 6 Wall Construction

Add new section  
R602.3.5

**R602.3.5 Fasteners.** Nails and staples shall conform to the requirements of ASTM F1667.

## **R602.3.5.1 Staples.**

**R602.3.5.1.1 General.** Staples shall be manufactured from No. 18 [0.0475 inch (1.21 mm)], No. 16 [0.0625 inch (1.59 mm)], No. 15 [0.072 inch (1.83 mm)] and No. 14 [0.080 inch (2.03 mm)] gage, round, semi-flattened or flattened, plain or zinc-coated steel wire, and driven with power tools. The staples shall be available with outside crown widths varying from 3/16 inch to 1 inch (4.8 mm to 25 mm). Leg lengths vary from 5/8 inch to 3 1/2 inches (15.9 mm to 89 mm). Staples shall be collated into strips and coated with polymer coatings. Staples manufactured from aluminum and copper wire are permitted in nonstructural applications only. Staple crown widths and leg lengths specified in Table R602.3(1) are overall dimensions.

**R602.3.5.1.2 Staple bending moments (M).** For engineered and structural construction, steel staples with the minimum bending moment are required. No. 16 gage staples shall have a minimum average bending moment of 3.6 in.-lbs. (0.41 N-m); No. 15 gage staples shall have a minimum average bending moment 4.0 in.-lbs. (0.45 N-m); and No. 14 gage staples shall have a minimum average bending moment 4.3 in.-lbs. (0.49 N-m).

## **R602.3.5.2 Nails.**

**R602.3.5.2.1 General.** Nails shall be manufactured from plain steel wire, galvanized steel wire, aluminum wire, copper wire or stainless steel wire. Aluminum and copper nails are permitted in nonstructural applications only. Nail heads include full round heads or modified round heads such as clipped heads, "D" heads, notched heads, oval heads or T-shaped heads. Nails are supplied with smooth or deformed (threaded) shanks. Deformed shanks may be annularly threaded (ring shank) or helically threaded (screw shank). Nails power driven shall be collated and coated into strips, clips or coils for loading into a power driving tool. Nails with T-shaped heads are permitted in nonstructural connections only. Table R602.3(1a) lists shank lengths and diameters for nails.

**R602.3.5.2.2 Nail bending yield strength ( $F_{yb}$ ).** For engineered and structural construction, steel nails meeting the minimum bending yield strength are required. Nails formed from steel wire having a nominal diameter of 0.135 inch (3.4 mm) or less shall have a minimum average bending yield strength of 100 ksi (689 MPa), and nails with diameters greater than 0.135 inch (3.4 mm) shall have a minimum average bending yield strength of 90 ksi (620 MPa). The 20d common nails described in Table R602.3(1a) shall have a minimum average bending yield strength of 80 ksi (55 MPa).

**Table R602.3  
(1) delete IRC  
and  
substitute  
new table-add  
footnote 5 at  
table header**

**TABLE R602.3  
WALL FRAMING**

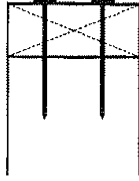
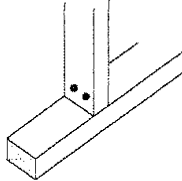
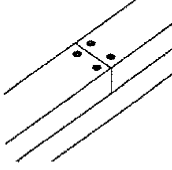
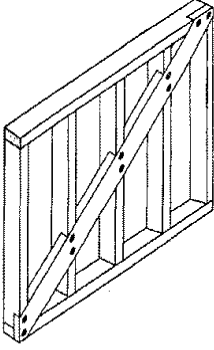
Connection <sup>2</sup> (Nail size and position exaggerated for illustrative purposes.)	Fastener Minimum nominal length in inches x Minimum nominal nail diameter in inches	Quantity per connection, Or Spacing between fasteners (inches on- center) <sup>4</sup>
Top or sole plate to stud (face nail)  	3½" x 0.162" nail (16d common) <sup>3</sup>	2
	3" x 0.148" nail (10d common)	3
	¾" x 0.131" nail	
	3" x 0.131" nail	
	¾" x 0.120" nail	
	3" x 0.120" nail	4
Stud to top or sole plate (toe nail)  	2½" x 0.131" nail (8d common) <sup>3</sup>	4
	¾" x 0.162" nail (16d common)	3
	3" x 0.148" nail (10d common)	4
	¾" x 0.131" nail	
	3" x 0.131" nail	
	¾" x 0.120" nail	
	3" x 0.120" nail	5
	2¾" x 0.113" nail	
	2" x 0.113" nail	
	2¼" x 0.105" nail	
2¼" x 0.099" nail	5	
Cap/top plate laps and intersections  	¾" x 0.162" nail (16d common) <sup>3</sup>	2 each side of lap
	3" x 0.148" nail	3 each side of lap
	¾" x 0.131" nail	
	3" x 0.131" nail	
	¾" x 0.120" nail	
	3" x 0.120" nail	
Diagonal bracing  	2½" x 0.131" nail (8d common) <sup>3</sup>	2
	¾" x 0.162" nail (16d common)	
	3" x 0.148" nail (10d common)	
	¾" x 0.131" nail	
	3" x 0.131" nail	3
	¾" x 0.120" nail	
	3" x 0.120" nail	
	2¾" x 0.113" nail	4
	2" x 0.113" nail	
	2¼" x 0.105" nail	
2¼" x 0.099" nail		

<sup>3</sup>Common 20 for fasteners



(102:30)  
**TABLE 23, continued**  
**WALL FRAMING<sup>1,5</sup>**



Connection <sup>2</sup> (Nail size and position exaggerated for illustrative purposes.)	Fastener Minimum nominal length in inches x Minimum nominal nail diameter in inches	Quantity per connection, Or Spacing between fasteners (inches on-center) <sup>4</sup>
Sole plate to joist or blocking @ braced panels 	3½" x 0.135" nail (16d box) <sup>3</sup>	3 per 16" space
	3½" x 0.162" nail (16d common)	2 per 16" space
	3" x 0.148" nail (10d common)	3 per 16" space
	¾" x 0.131" nail	
	3" x 0.131" nail	4 per 16" space
	¾" x 0.120" nail	
	3" x 0.120" nail	
Sole plate to joist or blocking 	3½" x 0.162" nail (16d common) <sup>3</sup>	16" o.c.
	3" x 0.148" nail (10d common)	8" o.c.
	¾" x 0.131" nail	
	3" x 0.131" nail	
	¾" x 0.120" nail	
	3" x 0.120" nail	
Double top plate 	3" x 0.148" nail (10d common) <sup>3</sup>	16" o.c.
	3½" x 0.162" nail (16d common)	12" o.c.
	¾" x 0.131" nail	
	3" x 0.131" nail	
	¾" x 0.120" nail	
	3" x 0.120" nail	
Double studs 	3" x 0.148" nail (10d common) <sup>3</sup>	12" o.c.
	3½" x 0.162" nail (16d common)	8" o.c.
	¾" x 0.131" nail	
	3" x 0.131" nail	
	¾" x 0.120" nail	
	3 x 0.120" nail	
Corner studs 	3½" x 0.162" nail (16d common) <sup>3</sup>	24" o.c.
	3" x 0.148" nail (10d common)	16" o.c.
	¾" x 0.131" nail	
	3" x 0.131" nail	
	¾" x 0.120" nail	12" o.c.
	3" x 0.120" nail	

TABLE *R602.30 continued*  
 CEILING AND ROOF FRAMING *15*

Connection <sup>4</sup> (Nail size and position exaggerated for illustrative purposes.)	Fastener Minimum nominal length in inches x Minimum nominal nail diameter in inches	Quantity per connection <sup>4</sup>	
Ceiling joist to plate  	3½" x 0.162" nail (16d common) <sup>3</sup>	3	
	3" x 0.148" nail (10d common)	4	
	¾" x 0.131" nail	5	
	3" x 0.131" nail		
	¾" x 0.120" nail		
	3" x 0.120" nail		
	2¾" x 0.113" nail	6	
Ceiling joists, laps over partitions  	Ceiling joist to parallel rafter  	3½" x 0.162" nail (16d common) <sup>3</sup>	3
		3" x 0.148" nail (10d common)	4
		¾" x 0.131" nail	
		3" x 0.131" nail	
		¾" x 0.120" nail	
		3" x 0.120" nail	
Collar tie to rafter  	3" x 0.148" nail (10d common) <sup>3</sup>	3	
	¾" x 0.162" nail (16d common)	4	
	¾" x 0.131" nail		
	3" x 0.131" nail		
	¾" x 0.120" nail		
	3" x 0.120" nail		
Jack rafter to hip, toe-nailed  	3" x 0.148" nail (10d common) <sup>3</sup>	3	
	¾" x 0.162" nail (16d common)	4	
	¾" x 0.131" nail		
	3" x 0.131" nail		
	¾" x 0.120" nail		
	3" x 0.120" nail		

R602,300

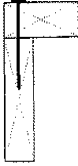
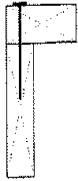
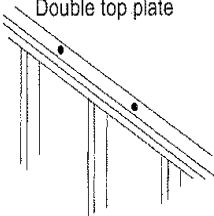
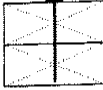
TABLE 2, continued  
CEILING AND ROOF FRAMING 1/5

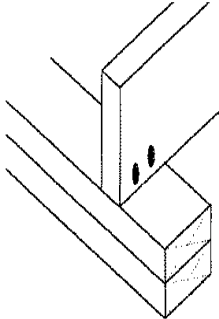
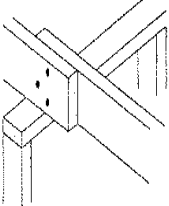
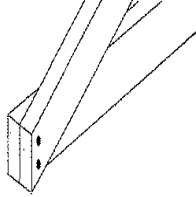
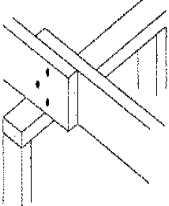
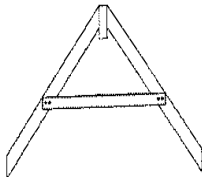
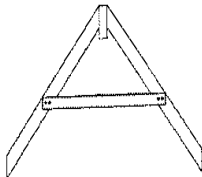
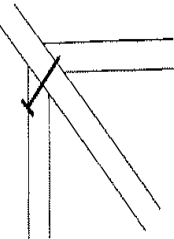
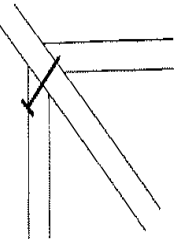
Connection <sup>2</sup> (Nail size and position exaggerated for illustrative purposes.)	Fastener Minimum nominal length in inches x Minimum nominal nail diameter in inches	Quantity per connection <sup>4</sup>
<p>Jack rafter to hip, face nailed</p> 	3½" x 0.162" nail (16d common) <sup>3</sup>	2
	3" x 0.148" nail (10d common)	3
	¾" x 0.131" nail	
	3" x 0.131" nail	
	¾" x 0.120" nail	4
	3" x 0.120" nail	
<p>Roof rafter to plate (toe-nailed)</p> 	2½" x 0.131" nail (8d common) <sup>3</sup>	3
	3½" x 0.162" nail (16d common)	
	3" x 0.148" nail (10d common)	
	¾" x 0.131" nail	
	3" x 0.131" nail	4
	¾" x 0.120" nail	
	3" x 0.120" nail	5
	2¾" x 0.113" nail	
	2" x 0.113" nail	
	2½" x 0.105" nail	6
2¼" x 0.099" nail		
<p>Roof rafter to 2-by ridge beam, face nailed</p>  <p>(Only the attachment of the top rafter is illustrated.)</p>	3½" x 0.162" nail (16d common) <sup>3</sup>	2
	3" x 0.148" nail (10d common)	3
	¾" x 0.131" nail	
	3" x 0.131" nail	4
	¾" x 0.120" nail	
	3" x 0.120" nail	
<p>Roof rafter to 2-by ridge beam, toe-nailed</p> 	3½" x 0.162" nail (16d common) <sup>3</sup>	2
	3" x 0.148" nail (10d common)	3
	¾" x 0.131" nail	
	3" x 0.131" nail	
	¾" x 0.120" nail	4
	3" x 0.120" nail	

TABLE 2-1602.30 continued  
 FLOOR FRAMING 15

Connection <sup>2</sup> (Nail size and position exaggerated for illustrative purposes.)		Fastener Minimum nominal length in inches x Minimum nominal nail diameter in inches	Quantity per connection or maximum spacing <sup>4</sup>	
Joist to band joist  		3½" x 0.162" nail (16d common) <sup>3</sup>	3	
		3" x 0.148" nail (10d common)	5	
		¾" x 0.131" nail		
		3" x 0.131" nail		
		¾" x 0.120" nail	6	
		3" x 0.120" nail		
Ledger strip  		3½" x 0.162" nail (16d common) <sup>3</sup>	3	
		3" x 0.148" nail (10d common)	4	
		¾" x 0.131" nail		
		3" x 0.131" nail		
		¾" x 0.120" nail	4	
		3" x 0.120" nail		
Joist to sill or girder (toe-nailed)  	Blocking between joist or rafter to top plate (toe-nailed)  	2½" x 0.131" nail (8d common) <sup>3</sup>	3	
				3" x 0.148" nail (10d common)
				¾" x 0.131" nail
			3" x 0.131" nail	4
			¾" x 0.120" nail	
			3" x 0.120" nail	
Bridging to joist (listed number of fasteners at each end)  		2½" x 0.131" nail (8d common) <sup>3</sup>	2	
		¾" x 0.120"	3	
		3" x 0.120" nail		
		2⅞" x 0.113" nail		
		2" x 0.113" nail (6d common)	4	
		2¼" x 0.105" nail	3	
		2¼" x 0.099" nail	4	

R602.3(1)  
**TABLE 23, continued**  
**FLOOR FRAMING<sup>1,5</sup>**

Connection <sup>2</sup> (Nail size and position exaggerated for illustrative purposes.)	Fastener Minimum nominal length in inches x Minimum nominal nail diameter in inches		Quantity per connection or maximum spacing <sup>4</sup>
Rim joist to top plate (toe-nailed)  	2½" x 0.113" nail	(8d box) <sup>3</sup>	6" o.c.
	3½" x 0.162" nail	(16d common)	8" o.c.
	3" x 0.148" nail	(10d common)	6" o.c.
	¾" x 0.131" nail		
	3" x 0.131" nail		
	¾" x 0.120" nail		
	3" x 0.120" nail		4" o.c.
	⅝" x 0.113" nail		6" o.c.
	2" x 0.113" nail	(6d common)	3" o.c.
	¾" x 0.105" nail		
¾" x 0.099" nail			
Connection <sup>2</sup> (Nail size and position exaggerated for illustrative purposes.)	Fastener Minimum nominal length in inches x Minimum nominal nail diameter in inches	Spacing of fasteners along the top and bottom of beam, staggered on each side of each layer	Number of fasteners at each end and splice for each layer
Built-up Girders and Beams  	4" x 0.192" nail (20d common) <sup>3</sup>	32" o.c.	2
	3½" x 0.162" nail (16d common) 3" x 0.148" nail (10d common) ¾" x 0.131" nail 3" x 0.131" nail	24" o.c.	3
	¾" x 0.120" nail 3" x 0.120" nail	16" o.c.	3
	2½" x 0.131" nail (8d common)	16" o.c.	4

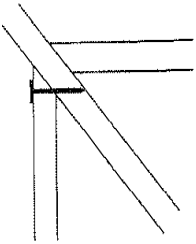
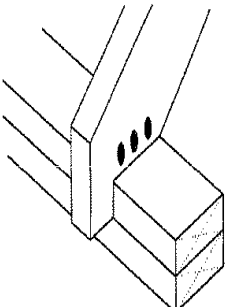
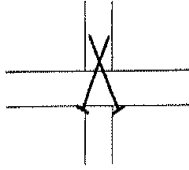
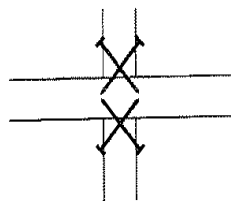
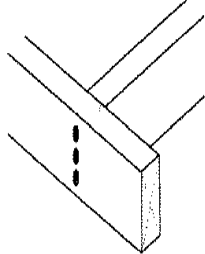
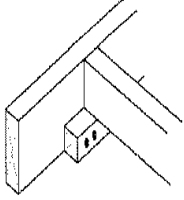
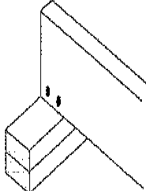
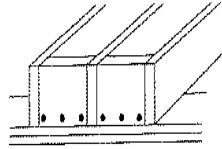
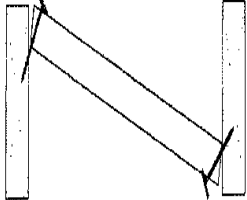
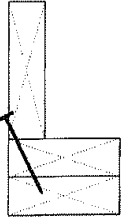
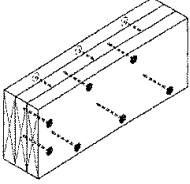
Change to 4"

Change to 4"

**Footnotes for Table R602.3(1)**

- <sup>1</sup> This fastening schedule applies to framing members having an actual thickness of 1 ½ " (nominal "2-by" lumber).
- <sup>2</sup> Fastenings listed above may also be used for other connections than are not listed but that have the same configuration and the same code requirement for fastener quantity/spacing and fastener size (pennyweight and style, e.g., 8d common, "8-penny common nail").
- <sup>3</sup> This fastener, in the quantity or spacing shown in the rightmost column, compromises the most stringent fastening of the connection listed in the International, National, International One and Two Family Dwelling, International Residential, Standard or Uniform Building Codes.
- <sup>4</sup> Fastening schedule only applies to buildings of conventional wood frame construction where wind and seismic analysis is not required by the applicable code. In areas where wind and seismic analysis is required, required fastening shall be determined by structural analysis. Following are conditions for which codes require structural analysis:  
  - For nominal dimensions of nails see Table R602.3(1a)
  - *North Carolina Residential Code* – buildings located in areas where the design wind speed equals or exceeds 110 mph (177.1 km/h) (3 second gust) or assigned to seismic design categories C, D1 and D2 (with detached one- and two-family dwellings in category C being exempt).
- <sup>5</sup> Reprinted from ESR-1539 with permission of ICC-ES.

**TABLE R602.3(1)—continued  
FASTENER SCHEDULE FOR STRUCTURAL MEMBERS**

DESCRIPTION OF BUILDING MATERIALS	DESCRIPTION OF FASTENER <sup>b, c, e</sup>	SPACING OF FASTENERS	
		Edges (inches) <sup>f</sup>	Intermediate supports <sup>c, e</sup> (inches)
<b>Wood structural panels, subfloor, roof and wall sheathing to framing, and particleboard wall sheathing to framing</b>			
$5/16$ "- $1/2$ "	6d common ( $2" \times 0.113"$ ) nail (subfloor, wall) 8d common ( $2\frac{1}{2}" \times 0.131"$ ) nail (roof) <sup>f</sup>	6	12 <sup>g</sup>
$19/32$ "- $1"$	8d common nail ( $2\frac{1}{2}" \times 0.131"$ )	6	12 <sup>g</sup>
$1\frac{1}{8}$ "- $1\frac{1}{4}$ "	10d common ( $3" \times 0.148"$ ) nail or 8d ( $2\frac{1}{2}" \times 0.131"$ ) deformed nail	6	12
<b>Other wall sheathing<sup>h</sup></b>			
$1/2$ " structural cellulosic fiberboard sheathing	$1\frac{1}{2}$ " galvanized roofing nail 8d common ( $2\frac{1}{2}" \times 0.131"$ ) nail; staple 16 ga., $1\frac{1}{2}$ " long	3	6
$25/32$ " structural cellulosic fiberboard sheathing	$1\frac{3}{4}$ " galvanized roofing nail 8d common ( $2\frac{1}{2}" \times 0.131"$ ) nail; staple 16 ga., $1\frac{3}{4}$ " long <sup>g</sup>	3	6
$1/2$ " gypsum sheathing <sup>d</sup>	$1\frac{1}{2}$ " galvanized roofing nail; 6d common ( $2" \times 0.131"$ ) nail; staple galvanized $1\frac{1}{2}$ " long; $1\frac{1}{4}$ " screws, Type W or S	4	8
$5/8$ " gypsum sheathing <sup>d</sup>	$1\frac{3}{4}$ " galvanized roofing nail; 8d common ( $2\frac{1}{2}" \times 0.131"$ ) nail; staple galvanized $1\frac{5}{8}$ " long; $1\frac{5}{8}$ " screws, Type W or S	4	8
<b>Wood structural panels, combination subfloor underlayment to framing</b>			
$3/4$ " and less	6d deformed ( $2" \times 0.120"$ ) nail or 8d common ( $2\frac{1}{2}" \times 0.131"$ ) nail	6	12
$7/8$ "- $1"$	8d common ( $2\frac{1}{2}" \times 0.131"$ ) nail or 8d deformed ( $2\frac{1}{2}" \times 0.120"$ ) nail	6	12
$1\frac{1}{8}$ "- $1\frac{1}{4}$ "	10d common ( $3" \times 0.148"$ ) nail or 8d deformed ( $2\frac{1}{2}" \times 0.120"$ ) nail	6	12

**TABLE R602.3(1), continued  
FASTENER SCHEDULE FOR STRUCTURAL MEMBERS<sup>j</sup>**

For SI: 1 inch = 25.4 mm, 1 foot = 304.8 mm, 1 mile per hour = 0.447 m/s; 1ksi = 6.895 MPa.

- a. Not used.
- b. Staples are 16 gage wire and have a minimum 7/16-inch on diameter crown width.
- c. Nails shall be spaced at not more than 6 inches on center at all supports where spans are 48 inches or greater.
- d. Four-foot-by-8-foot or 4-foot-by-9-foot panels shall be applied vertically.
- e. Spacing of fasteners not included in this table shall be based on Table R602.3(2).
- f. For regions having basic wind speed of 110 mph or greater, 8d deformed ( $2\frac{1}{2}" \times 0.120$ ) nails shall be used for attaching plywood and wood structural panel roof sheathing to framing within minimum 48-inch distance from gable end walls, if mean roof height is more than 25 feet, up to 35 feet maximum.
- g. For regions having basic wind speed of 100 mph or less, nails for attaching wood structural panel roof sheathing to gable end wall framing shall be spaced 6 inches on center. When basic wind speed is greater than 100 mph, nails for attaching panel roof sheathing to intermediate supports shall be spaced 6 inches on center for minimum 48-inch distance from ridges, eaves and gable end walls; and 4 inches on center to gable end wall framing.
- h. Gypsum sheathing shall conform to ASTM C 79 and shall be installed in accordance with GA 253. Fiberboard sheathing shall conform to ASTM C 208.
- i. Spacing of fasteners on floor sheathing panel edges applies to panel edges supported by framing members and required blocking and at all floor perimeters only. Spacing of fasteners on roof sheathing panel edges applies to panel edges supported by framing members and required blocking. Blocking of roof or floor sheathing panel edges perpendicular to the framing members need not be provided except as required by other provisions of this code. Floor perimeter shall be supported by framing members or solid blocking. Roof sheathing 7/16-inch or greater in thickness does not require perimeter blocking.
- i. For nominal dimensions of nails see Table R602.3(1a).

Insert new table R602.3 (1a)

**TABLE R602.3(1a)**  
**NOMINAL DIMENSIONS OF NAILS LISTED IN**  
**TABLE R602.3(1)**

Nails Described by Pennyweight System		
Pennyweight	Length, in inches	Shank Diameter, in inches
Box		
6d	2	0.099
8d	2½	0.113
10d	3	0.128
Casing		
6d	2¼	0.099
8d	2½	0.113
10d	3	0.128
Common		
6d	2	0.113
8d	2½	0.131
10d	3	0.148
16d	3½	0.162
20d	4	0.192
Cooler		
5d	1⅝	0.086
6d	1⅞	0.092
8d	2⅝	0.113
Deformed <sup>1</sup>		
3d	1¼	0.099
4d	1½	0.099
6d	2	0.120
8d	2½	0.120
Finish		
8d	2½	0.099
10d	3	0.113
Siding		
6d	1⅞	0.106
8d	2⅝	0.128
Additional Recognized Nails		
Smooth Shank Nails	2¼	0.092
	2¼	0.105
	3	0.120
	3¼	
	1½	0.131
	3	
	3¼	
	1½	0.148
2 ½	0.162	
Deformed Shank Nails <sup>1</sup>	2¼	0.099
	2	0.113
	2⅝	
	2½	0.131

<sup>1</sup>A deformed shank nail shall have either a helical (screw) shank or an annular (ring) shank.

**Figure 602.3  
(2)**

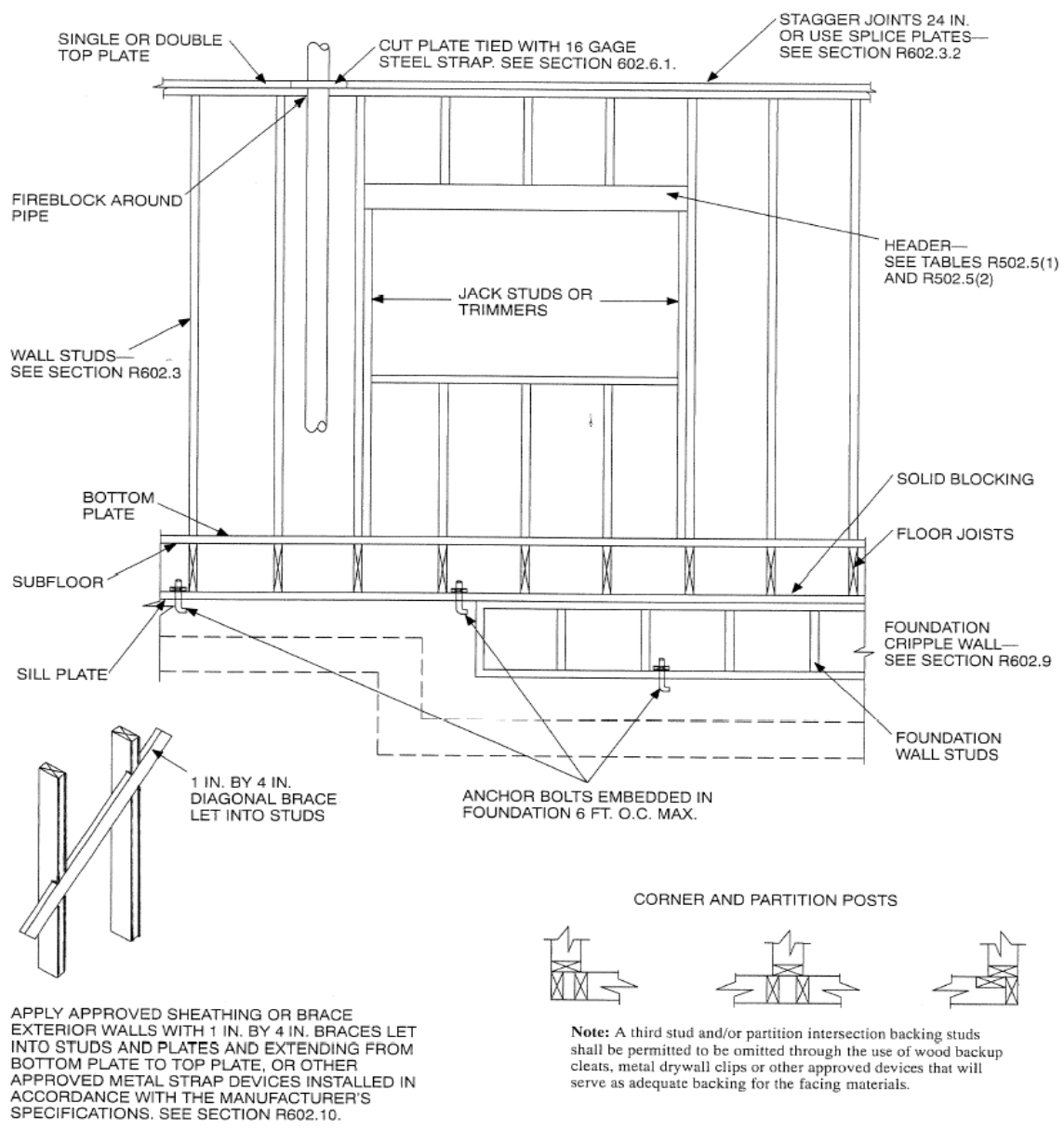

For SI: 1 inch = 25.4 mm, 1 foot = 304.8 mm.





**FIGURE R602.3(2)  
FRAMING DETAILS**

**Keep NC Figure showing let in braces**



**Table R602.3  
(5)**

**TABLE R602.3(5)  
SIZE, HEIGHT AND SPACING OF WOOD STUDS<sup>a</sup>**

STUD SIZE (inches)	BEARING WALLS					NONBEARING WALLS	
	Laterally unsupported stud height <sup>a</sup> (feet)	Maximum spacing when supporting a roof-ceiling assembly or a habitable attic assembly, only (inches)	Maximum spacing when supporting one floor, plus a roof-ceiling assembly or a habitable attic assembly (inches)	Maximum spacing when supporting two floors, plus a roof-ceiling assembly or a habitable attic assembly (inches)	Maximum spacing when supporting one floor height <sup>a</sup> (feet)	Laterally unsupported stud height <sup>a</sup> (feet)	Maximum spacing (inches)
							
2 x 3 <sup>b</sup>	—	—	—	—	—	10	16
2 x 4	10	24 <sup>c</sup>	16 <sup>c</sup>	—	24	14	24
3 x 4	10	24	24	16	24	14	24
2 x 5	10	24	24	—	24	16	24
2 x 6	10	24	24	16	24	20	24

For SI: 1 inch = 25.4 mm, 1 foot = 304.8 mm, 1 square foot = 0.093 m<sup>2</sup>.  
 a. Listed heights are distances between points of lateral support placed perpendicular to the plane of the wall. Increases in unsupported height are permitted where justified by analysts.  
 b. Shall not be used in exterior walls.  
 c. A habitable attic assembly supported by 2 x 4 studs is limited to a roof span of 32 feet. Where the roof span exceeds 32 feet, the wall studs shall be increased to 2 x 6 or the studs shall be designed in accordance with accepted engineering practice.

Add footnote d and include in header

**d. One half of the studs interrupted by a wall opening shall be placed immediately outside the jack studs on each side of the opening as king studs to resist wind loads. King studs shall extend full height from sole plate to top plate of the wall.**

**Table  
R602.3.1**

**TABLE R602.3.1  
MAXIMUM ALLOWABLE LENGTH OF WOOD WALL STUDS EXPOSED TO WIND SPEEDS OF 100 mph OR LESS  
IN SEISMIC DESIGN CATEGORIES A, B, C, D<sub>0</sub>, D<sub>1</sub> and D<sub>2</sub><sup>a, c</sup>**

HEIGHT (feet)	ON-CENTER SPACING (inches)			
	24	16	12	8
	Supporting a roof only			
>10	2 x 4	2 x 4	2 x 4	2 x 4
12	2 x 6	2 x 4	2 x 4	2 x 4
14	2 x 6	2 x 6	2 x 6	2 x 4
16	2 x 6	2 x 6	2 x 6	2 x 4
18	NA <sup>a</sup>	2 x 6	2 x 6	2 x 6
20	NA <sup>a</sup>	NA <sup>a</sup>	2 x 6	2 x 6
24	NA <sup>a</sup>	NA <sup>a</sup>	NA <sup>a</sup>	2 x 6
	Supporting one floor and a roof			
>10	2 x 6	2 x 4	2 x 4	2 x 4
12	2 x 6	2 x 6	2 x 6	2 x 4
14	2 x 6	2 x 6	2 x 6	2 x 6
16	NA <sup>a</sup>	2 x 6	2 x 6	2 x 6
18	NA <sup>a</sup>	2 x 6	2 x 6	2 x 6
20	NA <sup>a</sup>	NA <sup>a</sup>	2 x 6	2 x 6
24	NA <sup>a</sup>	NA <sup>a</sup>	NA <sup>a</sup>	2 x 6
	Supporting two floors and a roof			
>10	2 x 6	2 x 6	2 x 4	2 x 4
12	2 x 6	2 x 6	2 x 6	2 x 6
14	2 x 6	2 x 6	2 x 6	2 x 6
16	NA <sup>a</sup>	NA <sup>a</sup>	2 x 6	2 x 6
18	NA <sup>a</sup>	NA <sup>a</sup>	2 x 6	2 x 6
20	NA <sup>a</sup>	NA <sup>a</sup>	NA <sup>a</sup>	2 x 6
22	NA <sup>a</sup>	NA <sup>a</sup>	NA <sup>a</sup>	NA <sup>a</sup>
24	NA <sup>a</sup>	NA <sup>a</sup>	NA <sup>a</sup>	NA <sup>a</sup>

For SI: 1 inch = 25.4 mm, 1 foot = 304.8 mm, 1 pound per square foot = 0.0479 kPa, 1 pound per square inch = 6.895 kPa, 1 mile per hour = 0.447 m/s.  
 a. Design required.  
 b. Applicability of this table assumes the following: Snow load not exceeding 25 psf,  $f_b$  not less than 1310 psi determined by multiplying the AF&PA NDS tabular base design value by the repetitive use factor, and by the size factor for all species except southern pine, E not less than  $1.6 \times 10^6$  psi, tributary dimensions for floors and roofs not exceeding 6 feet, maximum span for floors and roof not exceeding 12 feet, eaves not over 2 feet in dimension and exterior sheathing. Where the conditions are not within these parameters, design is required.  
 c. Utility, standard, stud and No. 3 grade lumber of any species are not permitted.

Add footnote d and include in header

**d. One half of the studs interrupted by a wall opening shall be placed immediately outside the jack studs on each side of the opening as king studs to resist wind loads. King studs shall extend full height from sole plate to top plate of the wall.**

<b>R602.6</b>	<p><b>R602.6 Drilling and notching-studs.</b> Drilling and notching of studs shall be in accordance with the following:</p> <p>1. Notching. Any stud in an exterior wall or bearing partition may be cut or notched to a depth not exceeding 25 percent of its width. Studs in nonbearing partitions may be notched to a depth not to exceed 40 percent of a single stud width. <u>Notching of bearing studs shall be on one edge only and not to exceed one-fourth the height of the stud. Notching shall not occur in the bottom or top 6 inches (152 mm) of bearing studs.</u></p> <p>2. Drilling. Any stud may be bored or drilled, provided that the diameter of the resulting hole is no more than 60 percent of the stud width, the edge of the hole is no more than 5/8 inch (16 mm) to the edge of the stud, <u>and the hole shall not be closer than 6 inches (152 mm) from an adjacent hole or notch. Holes not exceeding 3/4 inch (19 mm) diameter can be as close as 1 1/2 inches (38 1 mm) on center spacing.</u> Studs located in exterior walls or bearing partitions drilled over 40 percent and up to 60 percent shall also be doubled with no more than two successive doubled studs bored. See Figures R602.6(1) and R602.6(2).</p> <p><b>Exception:</b> Use of approved stud shoes is permitted when they are installed in accordance with the manufacturer's recommendations.</p> <p><u>3. Cutting and notching of studs may be increased to 65% of the width of the stud in exterior and interior walls and bearing partitions, provided that one of the following conditions are met:</u></p> <p>(a) <u>The wall section is reinforced with 1/2 inch exterior grade plywood or equivalent reinforcement on the notched side of the wall. Plywood, if used, shall reach from the floor to ceiling and at least one stud further on each side of the section that has been notched or cut.</u></p> <p>(b) <u>The exterior walls of a kitchen may be reinforced by placing 1/2 inch plywood or equivalent reinforcement on the notched side of the wall. Plywood, if used, shall reach from the floor to counter-top height and at least one stud further on each side of the section that has been notched or cut.</u></p>
<b>Figure R602.6.1</b>	<b><u>Change figure R602.6.1 to reflect text 8-10d nails not 16d as indicated in text</u></b>
<b>R606.1.1</b>	<b>Professional registration not required.</b> When the empirical design provisions of ACI 530/ASCE 5/TMS 402 Chapter 5 or the provisions of this section are used to design masonry, project drawings, typical details and specifications are not required to bear the seal of the architect or engineer.
<b>R606.1.2</b>	<b>Used brick.</b> Used materials shall not be used unless such materials conform to these requirements and <u>have been cleaned.</u> <b>Exception:</b> Used materials may be used for interior nonbearing conditions
<b>R606.6.1</b>	<b>Pier cap.</b> Hollow piers shall be capped with 4 inches (102 mm) of solid masonry or concrete <u>for one story and 8 inches of solid masonry or concrete for two story and two and one-half story</u> or shall have cavities of the top course filled with concrete or grout or other approved methods.
<b>R607.2.1</b>	<b>Bed and head joints.</b> Unless otherwise required or indicated on the project drawings, head and bed joints shall be 3/8 inch (10 mm) thick, except that the thickness of the bed joint of the starting course placed over foundations shall not be less than 1/4 inch (7 mm) and not more than <u>1 1/2 inch (38 mm).</u>
<b>R602.10.1.4.1</b>	<b>Delete</b>
<b>R602.10.1.5</b>	<b>Delete</b>
<b>R602.10.6.1</b>	<b>Delete</b>
<b>R602.10.7.1</b>	<b>Delete</b>

<b>R602.10.9.1</b>	Delete
<b>R602.11.2</b>	Delete
<b>R602.12.1</b>	Delete (delete from .1 to .6)
<b>Table R602.12 (2)</b>	Delete

**Table R602.10.4.2**

TABLE R602.10.4.2 LENGTH REQUIREMENTS FOR BRACED WALL PANELS WITH CONTINUOUS SHEATHING <sup>a</sup> (inches)						
METHOD	ADJACENT CLEAR OPENING HEIGHT (inches)	WALL HEIGHT (feet)				
		8	9	10	11	12
CS-WSP	64	24	27	30	33	36
	68	26	27	30	—	—
	72	28	27	30	—	—
	76	29	30	30	—	—
	80	31	33	30	—	—
	84	35	36	33	—	—
	88	39	39	36	—	—
	92	44	42	39	—	—
	96	48	45	42	—	—
	100	—	48	45	—	—
	104	—	51	48	—	—
	108	—	54	51	—	—
	112	—	—	54	44	—
	116	—	—	57	—	—
	120	—	—	60	—	—
	122	—	—	—	—	48
132	—	—	—	66	—	
144	—	—	—	—	75	
CS-G	≤ 120	24	27	30	—	—
CS-PF	≤ 120	16	18	20	—	—

For SI: 1 inch = 25.4 mm, 1 foot = 304.8 mm.  
a. Interpolation shall be permitted.

**Add footnote b**

b. Braced wall panels using (WSP) wood structural panel sheathing on both sides may be used to reduce the panel lengths shown by 50 percent.

**R611.1**

**General.** Insulating Concrete Form walls shall be designed and constructed in accordance with the provisions of this section or in accordance with the provisions of ACI 318. When ACI 318 or the provisions of this section are used to design insulating concrete form walls, project drawings, typical details and specifications are not required to *bear the seal of a registered design professional.*

## Chapter 7 Wall Covering

**R703.7 Stone and masonry veneer, general**

Delete exception #2

**R703.7.2.1 Support by steel angle**

A minimum 6 inches by 4 inches by 5/16 inch (152 mm by 102 mm by 8 mm) steel angle, with the long leg placed vertically, shall be anchored to double 2-inch by 4-inch (51mm by 102mm) wood studs at a maximum on center spacing of 16 inches (406 mm) or shall be anchored to solid double 2x blocking firmly attached between single 2-inch by 4-inch (51 mm

	<p>by 102 mm) wood studs at a maximum on center spacing of 16 inches (406 mm). Anchorage of the steel angle shall be a minimum of two 7/16-inch diameter (11.1 mm) by 4 inches (102mm) lag screws at every double stud or shall be a minimum of two 7/16-inch diameter (11.1 mm) by 4 inches (102 mm) lag screws into solid double blocking with each pair of lag screws spaced at horizontal intervals not to exceed 16 inches (406 mm). The steel angle shall have a minimum clearance to underlying construction of 1/16 inch (1.6 mm).</p> <p>A minimum of two-thirds the width of the masonry veneer thickness shall bear on the steel angle. Flashing and weep holes shall be located in the masonry veneer wythe in accordance with Figure R703.7.2.1. The maximum height of masonry veneer above the steel angle support shall be 12 feet, 8 inches (3861 mm). The air space separating the masonry veneer from the wood backing shall be in accordance with R703.7.4 and R703.7.4.2. The method of support for the masonry veneer on <u>steel angle</u> shall be constructed in accordance with Figure R703.7.2.1. The maximum slope of the roof construction without stops shall be 7:12. Roof construction with slopes greater than 7:12 but not more than 12:12 shall have stops of a minimum 3 inches x 3 inches x 1/4 inch (76mm x 76mm x 6 mm) steel plate welded to the angle at 24 inches (610 mm) on center along the angle or as approved by the building official.</p>
<p><b>R703.7.2.2 Support by roof construction</b></p>	<p><u>Veneer may be vertically supported on sloping surfaces as shown in Figure R703.7.2.2 and as described in the following provisions:</u></p> <ol style="list-style-type: none"> <li><u>1. Surface slope shall not exceed 12:12.</u></li> <li><u>2. Member supporting veneer loading shall have three times the capacity of similar beams, joist or rafters supporting the sloped surface.</u></li> <li><u>3. Minimum of 4 inch x 3 1/2 inch x 1/4 inch (102mm x 89 mm x 6 mm) steel angle shall be attached to the sloping surface. Attachment shall be made by drilling 3/16-inch (5mm) diameter holes in the 4-inch (102 mm) leg of the angle at 12 inches (305 mm) o.c. and using 16d nails penetrating the triple members. When the slope exceeds 7:12, minimum 3 inch x 3 inch x 1/4 inch (76 mm x 76 mm x 6 mm) plates shall be welded at 24 inches (610 mm) o.c. along the steel angle as stops to prevent the veneer from sliding down the slope. Minimum of 1-inch (25 mm) air space shall be maintained between the wall and veneer.</u></li> <li><u>4. Flashing shall be installed over steel angle and a minimum of 6 inches (152 mm) under the wall sheathing.</u></li> <li><u>5. Maximum height of 12 feet 8 inches (386 mm) above steel angle or as approved by a North Carolina design professional.</u></li> </ol>
<p><b>Figure R703.7</b></p>	<p>Delete</p>
<p><b>Table R703.7(2)</b></p>	<p>Delete</p>
<p><b>Figure R703.7.2.1 Exterior masonry veneer supported by steel angles</b></p>	<p>Use NC 2009 but add counter flashing detail:</p>

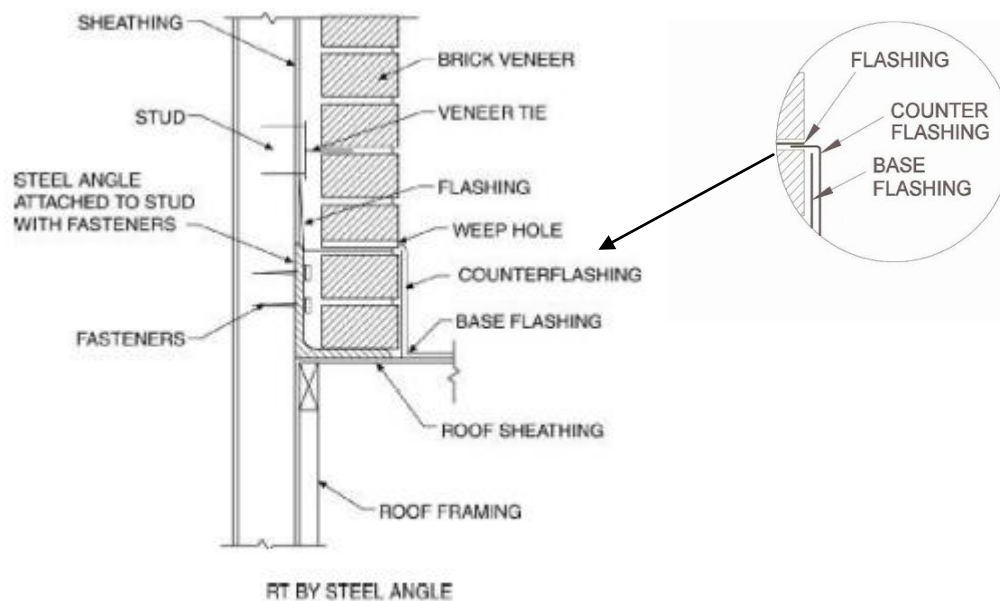

RT BY STEEL ANGLE  
 FIGURE R703.7.2.1  
 EXTERIOR MASONRY VENEER SUPPORT BY STEEL ANGLES

**Figure R703.7.2.2**  
 Exterior masonry veneer support by roof members

Use NC 2009 but add counter flashing detail:

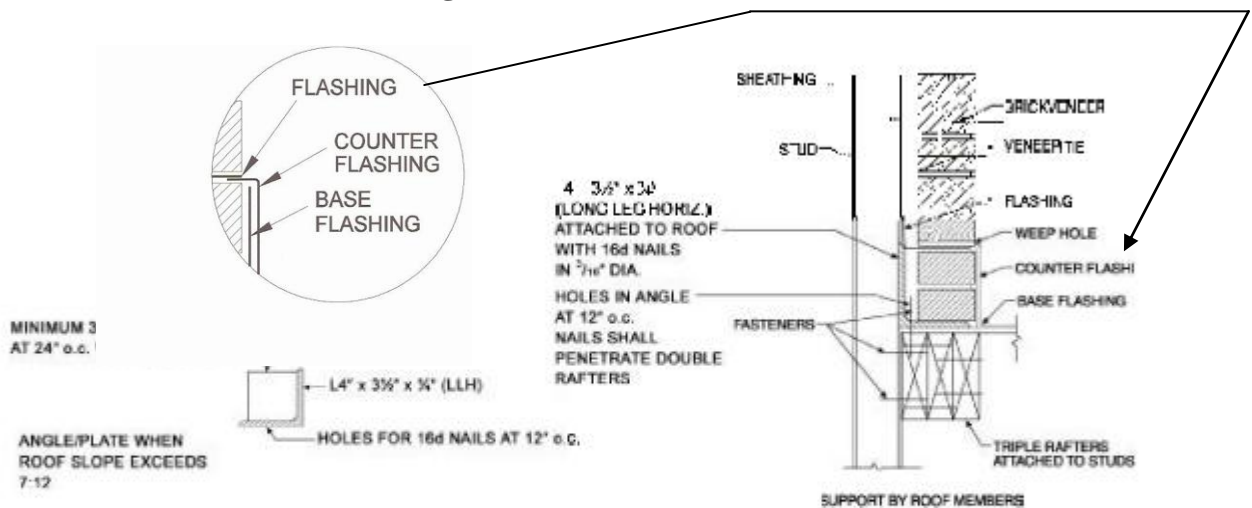

FIGURE R703.7.2.2  
 EXTERIOR MASONRY VENEER SUPPORT BY ROOF MEMBERS

**R703.7.3 Lintels**

**R703.7.3 Lintels.** Masonry veneer shall not support any vertical load other than the dead load of the veneer above. Veneer above openings shall be supported on lintels of noncombustible materials and the allowable span shall not exceed the value set forth in Table R703.7.3. The lintels shall have a length of bearing not less than 4 inches (102 mm).

**Table R703.7.3**

Add NC table

**TABLE R703.7.3**  
**ALLOWABLE SPANS FOR LINTELS**  
**SUPPORTING MASONRY VENEER**

SIZE OF STEEL ANGLE <sup>a,c</sup> (inches)	MAXIMUM SPAN <sup>b,d</sup>
$3\frac{1}{2} \times 3\frac{1}{2} \times \frac{1}{4}$	6'-0"
$5 \times 3\frac{1}{2} \times \frac{3}{16}$	10'-0"

For SI: 1 inch = 25.4 mm, 1 foot = 304.8 mm.

a. Long leg of the angle shall be placed in a vertical position.

b. Spans over 4 feet shall be shored up until cured.

c. Steel members indicated are adequate typical examples; other steel members including light-gage steel meeting structural design requirements may be used.

d. Spans over 10 feet shall be designed in accordance with approved standard.

<b>Table R703.7.3.1</b>	Delete
<b>Figure R703.7.3.2</b>	Delete
<b>R703.7.5 Flashing</b>	<b>R703.7.5 Flashing.</b> Flashing of 6 mil (0.152 mm) poly or other corrosion-resistive material shall be located beneath the first course of masonry above finished ground level above the foundation wall or slab and at other points of support, including structural floors, shelf angles and lintels when masonry veneers are designed in accordance with Section R703.7. Top of base flashing shall be installed with a minimum 2-inch (51 mm) lap behind building paper or water-repellent sheathing. See Section R703.8 for additional requirements.
<b>R703.8 Flashing</b>	<i>Approved</i> corrosion-resistant flashing shall be applied shingle-fashion in a manner to prevent entry of water into the wall cavity or penetration of water to the building structural framing components. <u>Install flashing in accordance with ASTM E 2112 Standard Practice for Installation of Exterior Windows, Doors and Skylights, or the manufacturer's supplied written instructions.</u> Aluminum flashing may not be used in contact with cementitious material, except at counter flashing. Self-adhered membranes used as flashing shall comply with AAMA 711. The flashing shall extend to the surface of the exterior wall finish. <i>Approved</i> corrosion-resistant flashings shall be installed at all of the following locations: <ol style="list-style-type: none"> <li>1. Exterior window and door openings. Flashing at exterior window and door openings shall extend to the surface of the exterior wall finish or to the water-resistive barrier for subsequent drainage.</li> <li>2. At the intersection of chimneys or other masonry construction with frame or stucco walls, with projecting lips on both sides under stucco copings.</li> <li>3. Under and at the ends of masonry, wood or metal copings and sills.</li> <li>4. Continuously above all projecting wood trim.</li> <li>5. Where exterior porches, decks or stairs attach to a wall or floor assembly of wood-frame construction.</li> <li>6. At wall and roof intersections.</li> <li>7. At built-in gutters.</li> </ol>
<b>R703.9 Exterior insulation and finish system EIFS with drainage</b>	Exterior Insulation and Finish System (EIFS) <del>shall comply with this chapter and Sections R703.9.1 and R703.9.3.</del> EIFS with drainage shall comply with this chapter and Sections R703.9.2, R703.9.3 and R703.9.4.
<b>R703.9.1 Exterior insulation and finish system (EIFS)</b>	<del>EIFS shall comply with ASTM E 2568.</del> Non-drainable EIFS shall not be permitted.
<b>R703.9.4 EIFS/EIFS with drainage installation</b>	All EIFS shall be installed in accordance with the manufacturer's installation instructions and the requirements of this section.
<b>Chapter 8 Roof-Ceiling Construction</b>	
<b>R802.3.1 Ceiling Joist and rafter connections</b>	Ceiling joists and rafters shall be nailed to each other in accordance with Table R802.5.1(9), and the rafter shall be nailed to the top wall plate in accordance with Table R602.3(1). Ceiling joists shall be continuous or securely joined in accordance with Table R802.5.1(9) where they meet over interior partitions and are nailed to adjacent rafters to provide a continuous tie across the building when such joists are parallel to the rafters. Where ceiling joists are not connected to the rafters at the top wall plate, joists connected higher in the <i>attic</i> shall be installed as rafter ties, or rafter ties shall be installed to provide a continuous tie. Where ceiling joists are not parallel to rafters, <u>subflooring or metal straps</u>

attached to the ends of the rafters shall be installed in a manner to provide a continuous tie across the building. Rafter ties shall be a minimum of 2-inch by 4-inch (51mm by 102mm) (nominal), installed in accordance with the connection requirements in Table R802.5.1 (9), or connections of equivalent capacities shall be provided. Where ceiling joists or rafter ties are not provided, the ridge formed by these rafters shall be supported by a wall or girder designed in accordance with accepted engineering practice. Rafter ties shall be spaced not more than 4 feet (1219mm) on center. Collar ties or ridge straps to resist wind uplift shall be connected in the upper third of the attic space in accordance with Table R602.3 (1). Collar ties shall be a minimum of 1-inch by 4-inch (25 mm by 102 mm) (nominal), spaced not more than 4 feet (1219 mm) on center.

**Figure R802.5.1**  
**Braced rafter construction**

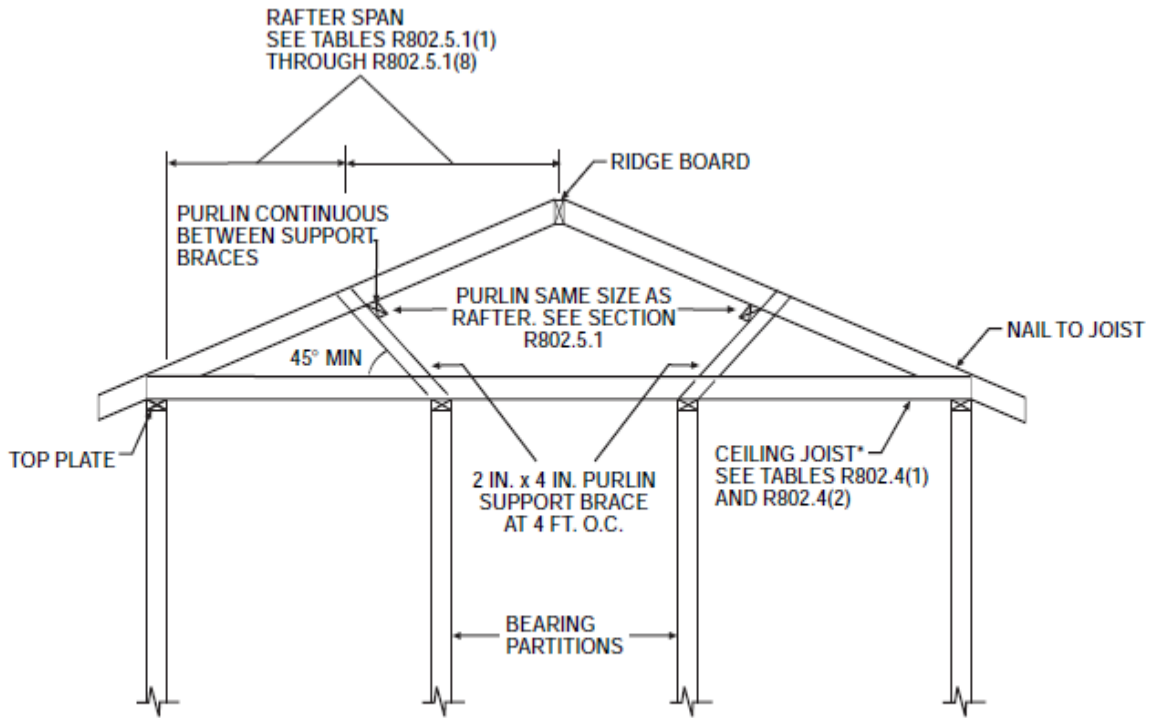

For SI: 1 inch = 25.4 mm, 1 foot = 305 mm, 1 degree = 0.018 rad.

Change note to read:

**Note: Where ceiling joists run perpendicular to the rafters, rafter ties shall be nailed to the rafter near the plate line and spaced not more than 4 feet on center.**

**Table R802.11** Change table header to match NC 2009



**TABLE R802.11**  
**REQUIRED STRENGTH OF TRUSS OR RAFTER CONNECTIONS TO RESIST WIND UPLIFT FORCES OF 20 PSF OR GREATER<sup>a, b, c, e, f</sup>**  
**(Pounds per connection)**

BASIC WIND SPEED (mph) (3-second gust)	ROOF SPAN (feet)							OVERHANGS <sup>d</sup> (pounds/foot)
	12	20	24	28	32	36	40	
85	-72	-120	-145	-169	-193	-217	-241	-38.55
90	-91	-151	-181	-212	-242	-272	-302	-43.22
100	-131	-218	-262	-305	-349	-393	-436	-53.36
110	-175	-292	-351	-409	-467	-526	-584	-64.56

For SI: 1 inch = 25.4 mm, 1 foot = 305 mm, 1 mph = 0.447 m/s, 1 pound/foot = 14.5939 N/m, 1 pound = 0.454 kg.

- The uplift connection requirements are based on a 30 foot mean roof height located in Exposure B. For Exposures C and D and for other mean roof heights, multiply the above loads by the Adjustment Coefficients in Table R301.2(3).
- The uplift connection requirements are based on the framing being spaced 24 inches on center. Multiply by 0.67 for framing spaced 16 inches on center and multiply by 0.5 for framing spaced 12 inches on center.
- The uplift connection requirements include an allowance for 10 pounds of dead load.
- The uplift connection requirements do not account for the effects of overhangs. The magnitude of the above loads shall be increased by adding the overhang loads found in the table. The overhang loads are also based on framing spaced 24 inches on center. The overhang loads given shall be multiplied by the overhang projection and added to the roof uplift value in the table.
- The uplift connection requirements are based on wind loading on end zones as defined in Figure 6-2 of ASCE 7. Connection loads for connections located a distance of 20% of the least horizontal dimension of the building from the corner of the building are permitted to be reduced by multiplying the table connection value by 0.7 and multiplying the overhang load by 0.8.
- For wall-to-wall and wall-to-foundation connections, the capacity of the uplift connector is permitted to be reduced by 100 pounds for each full wall above. (For example, if a 600-pound rated connector is used on the roof framing, a 500-pound rated connector is permitted at the next floor level down).

**R806.2**  
**Minimum area**

The total net free ventilating area shall not be less than 1/150 of the area of the space ventilated except that reduction of the total area to 1/300 is permitted provided that at least 50 percent and not more than 80 percent of the required ventilating area is provided by ventilators located in the upper portion of the space to be ventilated at least 3 feet (914 mm) above the eave or cornice vents with the balance of the required ventilation provided by eave or cornice vents. As an alternative, the net free cross-ventilation area may be reduced to 1/300 when a Class I or II vapor barrier is installed on the warm-in-winter side of the ceiling.

**Exceptions:**

1. Enclosed attic/rafter spaces requiring less than 1 square foot (0.0929 m<sup>2</sup>) of ventilation may be vented with continuous soffit ventilation only.
2. Enclosed attic/rafter spaces over unconditioned space may be vented with continuous soffit vent only.

**R807.1 Attic**  
**access**

An attic access opening shall be provided to attic areas that exceed 100 square feet (9.29 m<sup>2</sup>) and have a vertical height of 60 inches (1524 mm) or greater. The net clear opening shall not be less than 20 inches by 30 inches (508 mm by 762 mm) and shall be located in a hallway or other readily accessible location. A 30-inch (762 mm) minimum unobstructed headroom in the attic space shall be provided at some point above the access opening. See Section M1305.1.3 for access requirements where mechanical equipment is located in attics.

**Exception:** Concealed areas not located over the main structure, including porches, areas behind knee walls, dormers, bay windows, etc., are not required to have access.

## Chapter 9 Roof Assemblies

**R903.3**  
**Coping**

Parapet walls shall be properly coped with noncombustible, weatherproof materials of a width no less than the thickness of the parapet wall. *Parapet coping shall extend 2 inches minimum down the faces of the parapet.*

**R903.4.1**  
**Overflow**  
**drains and**  
**scuppers**

Where roof drains are required, overflow drains having the same size as the roof drains shall be installed with the inlet flow line located 2 inches (51 mm) above the low point of the roof, or overflow scuppers having three times the size of the roof drains and having a minimum opening height of 4 inches (102 mm) shall be installed in the adjacent parapet walls with the inlet flow located 2 inches (51 mm) above the low point of the roof served. The installation and sizing of overflow drains, leaders and



	conductors shall comply with the <u>North Carolina Plumbing Code</u> .  Overflow drains shall discharge to an approved location and shall not be connected to roof drain lines.
<b>R903.5 Hail exposure</b>	<b>Delete</b>
<b>R903.5.1</b>	<b>Delete</b>
<b>R903.5.2</b>	<b>Delete</b>
<b>Figure R903.5 Hail exposure map</b>	<b>Delete</b>
<b>R905.2.7.1 Ice Barrier</b>	In areas where <u>the average daily temperature in January is 25°F (-4°C) or less or when Table R301.2(1) criteria so designates</u> , an ice barrier that consists of a least two layers of underlayment cemented together or of a self-adhering polymer modified bitumen sheet, shall be used in lieu of normal underlayment and extend from the eave's edge to a point at least 24 inches (610 mm) inside the exterior wall line of the building. <b>Exception:</b> Detached accessory structures that contain no conditioned floor area.
<b>R905.4.3.1 Ice Barrier</b>	In areas where <u>the average daily temperature in January is 25°F (-4°C) or less or when Table R301.2(1) criteria so designates</u> , an ice barrier that consists of a least two layers of underlayment cemented together or of a self-adhering polymer modified bitumen sheet, shall be used in lieu of normal underlayment and extend from the eave's edge to a point at least 24 inches (610 mm) inside the exterior wall line of the building. <b>Exception:</b> Detached accessory structures that contain no conditioned floor area.
<b>R905.5.3.1 Ice Barrier</b>	In areas where <u>the average daily temperature in January is 25°F (-4°C) or less or when Table R301.2(1) criteria so designates</u> , an ice barrier that consists of a least two layers of underlayment cemented together or of a self-adhering polymer modified bitumen sheet, shall be used in lieu of normal underlayment and extend from the eave's edge to a point at least 24 inches (610 mm) inside the exterior wall line of the building. <b>Exception:</b> Detached accessory structures that contain no conditioned floor area.
<b>R905.6.3.1 Ice Barrier</b>	In areas where <u>the average daily temperature in January is 25°F (-4°C) or less or when Table R301.2(1) criteria so designates</u> , an ice barrier that consists of a least two layers of underlayment cemented together or of a self-adhering polymer modified bitumen sheet, shall be used in lieu of normal underlayment and extend from the eave's edge to a point at least 24 inches (610 mm) inside the exterior wall line of the building. <b>Exception:</b> Detached accessory structures that contain no conditioned floor area.
<b>R905.7.3.1 Ice Barrier</b>	In areas where <u>the average daily temperature in January is 25°F (-4°C) or less or when Table R301.2(1) criteria so designates</u> , an ice barrier that consists of a least two layers of underlayment cemented together or of a self-adhering polymer modified bitumen sheet, shall be used in lieu of normal underlayment and extend from the eave's edge to a point at least 24 inches (610 mm) inside the exterior wall line of the building. <b>Exception:</b> Detached accessory structures that contain no conditioned floor area.
<b>R905.8.3.1 Ice Barrier</b>	In areas where <u>the average daily temperature in January is 25°F (-4°C) or less or when Table R301.2(1) criteria so designates</u> , an ice barrier that consists of a least two layers of underlayment cemented together or of a self-adhering polymer modified bitumen sheet, shall be used in lieu of normal underlayment and extend from the eave's edge to a point at least 24 inches (610 mm) inside the exterior wall line of the building. <b>Exception:</b> Detached accessory structures that contain no conditioned floor area.
<b>R907.3 Recovering versus replacement</b>	<b>Delete #4</b>
<b>Chapter 10 Chimney's and Fireplaces</b>	

<b>R1001.2 Footings and foundations</b>	Footings for masonry fireplaces and their chimneys shall be constructed of concrete or solid masonry at least 12 inches (305 mm) thick and shall extend at least <u>12 inches (305 mm)</u> beyond the face of the fireplace or foundation wall on all sides. Footings shall be founded on natural, undisturbed earth or engineered fill below frost depth. In areas not subjected to freezing, footings shall be at least 12 inches (305 mm) below finished grade.
<b>Table R1001.1</b>	Use 2009 NC Table but delete footnote c

**TABLE R1001.1  
SUMMARY OF REQUIREMENTS FOR MASONRY FIREPLACES AND CHIMNEYS**

ITEM	LETTER <sup>a</sup>	REQUIREMENTS
Hearth slab thickness	A	4"
Hearth extension (each side of opening)	B	8" fireplace opening < 6 square foot. 12" fireplace opening ≥ 6 square foot.
Hearth extension <sup>g</sup> (front of opening)	C	16" fireplace opening < 6 square foot. 20" fireplace opening ≥ 6 square foot.
Hearth reinforcing	D	Reinforced to carry its own weight and all imposed loads.
Thickness of wall of firebox	E	10" solid brick or 8" where a firebrick lining is used. Joints in firebrick 1/4" maximum.
Distance from top of opening to throat	F	8"
Smoke chamber wall thickness	G	6"
Chimney Vertical reinforcing <sup>b</sup>	H	Four No. 4 full-length bars for chimney up to 40" wide. Add two No. 4 bars for each additional 40" or fraction of width or each additional flue.
Horizontal reinforcing <sup>h</sup>	J	1/4" ties at 18" and two ties at each bend in vertical steel.
Bond beams <sup>h</sup>	K	No specified requirements.
Fireplace lintel	L	Noncombustible material.
Chimney walls with flue lining	M	Solid masonry units or hollow masonry units grouted solid with at least 4 inch nominal thickness.
Distances between adjacent flues	-	See Section R 1003.13.
Effective flue area (based on area of fireplace opening)	P	See Section R1003.15.
Clearances: Combustible material Mantel and trim Above roof	R	See Sections R1001.11 and R1003.18. See Section R1001.11, Exception 4. 2' at roofline and 2' at 10'.
Anchorage <sup>b</sup> Strap Number Embedment into chimney Fasten to Bolts	S	3/16" x 1" Two 12" hooked around outer bar with 6" extension. 4 joists Three 1/2" diameter.
Footing Thickness Width	T	12" min. 12" each side of fireplace wall.

For SI: 1 inch = 25.4 mm, 1 foot = 304.8 mm, 1 square foot = 0.0929m<sup>2</sup>.

NOTE: This table provides a summary of major requirements for the construction of masonry chimneys and fireplaces. Letter references are to Figure R1001.1, which shows examples of typical construction. This table does not cover all requirements, nor does it cover all aspects of the indicated requirements. For the actual mandatory requirements of the code, see the indicated section of text.

a. The letters refer to Figure R1001.1.

h. Not required in Seismic Design Category A, B or C.

c. See Exception 2 Section 1003.11

Figure 1001.1

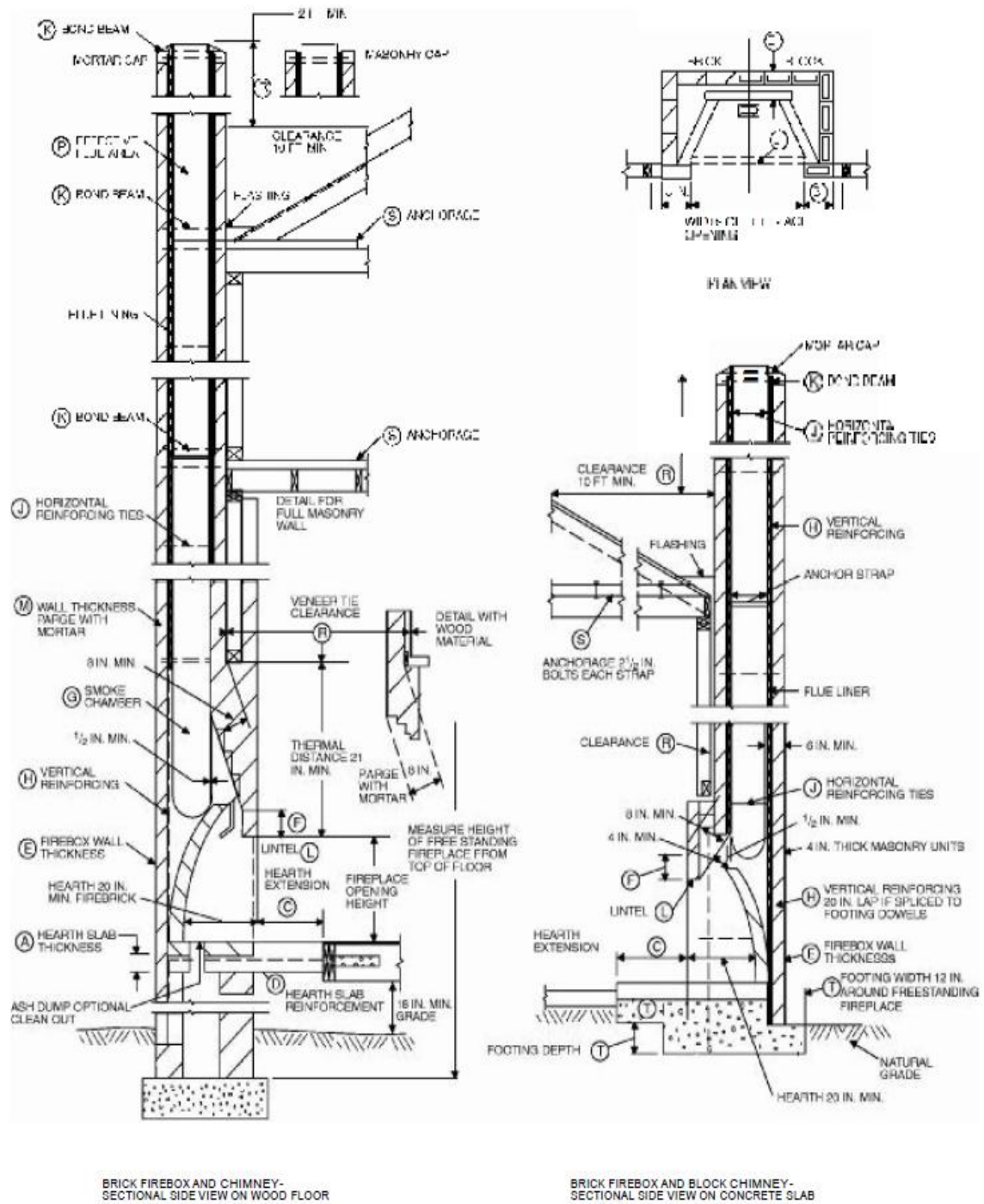

For SI: 1 inch = 25.4 mm, 1 foot = 304.8 mm.

FIGURE R1001.1  
FIREPLACE AND CHIMNEY DETAILS

Use figure out of NC 2009 code

**R1003.2**  
**Footings and foundations**

Footings for masonry chimneys shall be constructed of concrete or solid masonry at least 12 inches (305 mm) thick and shall extend at least 12 inches (305 mm) beyond the face of the foundation or support wall on all sides. Footings shall be founded on natural undisturbed earth or engineered fill below frost depth. In areas not subjected to freezing, footings shall be at least 12 inches (305 mm) below finished grade.

<b>R1003.12 Clay flue lining (installation)</b>	<p>Flue liners shall be installed in accordance with ASTM C 1283 and extend from a point not less than 8 inches (203 mm) below the lowest inlet or, in the case of fireplaces, from the top of the smoke chamber to a point above the enclosing walls. The lining shall be carried up vertically, with a maximum slope no greater than 30 degrees (0.52 rad) from the vertical.</p> <p>Clay flue liners shall be laid in medium-duty refractory mortar conforming to ASTM C 199 (<b>Types M and S</b>) with tight mortar joints left smooth on the inside and installed to maintain an air space or insulation not to exceed the thickness of the flue liner separating the flue liners from the interior face of the chimney masonry walls. Flue liners shall be supported on all sides. Only enough mortar shall be placed to make the joint and hold the liners in position.</p>
<b>R1005.1 listing (changed title to R1005.1 General)</b>	<p><b><u>Delete and replace with :</u></b></p> <p><u>Factory-built fireplace stoves, consisting of a freestanding fire chamber assembly, that have been tested and are listed by a nationally recognized testing laboratory, shall be installed in accordance with the requirements of said listing and the manufacturer's instructions. The supporting structure for a hearth extension shall be at the same level as the supporting structure for the fireplace unit of the firebox opening on or near the floor. The inlet shall be closable and designed to prevent burning material from dropping into concealed combustible spaces.</u></p>

# Chapter 11 Energy Efficiency

## Part IV---Energy Conservation

### CHAPTER 11

## ENERGY EFFICIENCY

### SECTION N1101 SCOPE, GENERAL REQUIREMENTS, AND ADDITIONAL DEFINITIONS

**N1101.1 Scope and Intent.** This chapter shall regulate the design and construction of buildings for the effective use of energy. This code is intended to provide flexibility to permit the use of innovative approaches and techniques to achieve the effective use of energy. This code is not intended to prevent the use of any material, method of construction, design or insulating system not specifically prescribed herein, provided that such construction, design or insulating system has been *approved* by the *code official* as meeting the intent of this code. This code is not intended to abridge safety, health or environmental requirements contained in other applicable codes or ordinances.

**N1101.1.1 Applicability.** Where, in any specific case, different sections of this code specify different materials, methods of construction or other requirements, the most restrictive shall govern. Where there is a conflict between a general requirement and a specific requirement, the specific requirement shall govern.

**N1101.1.2 Existing buildings.** Except as specified in this chapter, this code shall not be used to require the removal, *alteration* or abandonment of, nor prevent the continued use and maintenance of, an existing building or building system lawfully in existence at the time of adoption of this code.

**N1101.1.3 Additions, alterations, renovations or repairs.** Additions, alterations, renovations or repairs to an existing building, building system or portion thereof shall conform to the provisions of this code as they relate to new construction without requiring the unaltered portion(s) of the existing building or building system to comply with this code. Additions, alterations, renovations or repairs shall not create an unsafe or hazardous condition or overload existing building systems. An addition shall be deemed to comply with this code if the addition alone complies or if the existing building and addition comply with this code as a single building.

**Exception:** The following need not comply provided the energy use of the building is not increased:

1. Storm windows installed over existing fenestration.
2. Incidental repairs requiring a new sash or new glazing.
3. Existing ceiling, wall or floor cavities exposed during construction provided that these cavities are filled with insulation.
4. Construction where the existing roof, wall or floor cavity is not exposed.

**N1101.2 Compliance.** Compliance shall be demonstrated by either meeting the requirements of the *North Carolina Energy Conservation Code* or meeting the requirements of this chapter. Climate zones from Figures N1101.2(1), Figure N1101.2(2) or Table N1101.2 shall be used in determining the applicable requirements from this chapter. Projects shall comply with Sections N1101, N1102.4, N1102.5, and N1103.1, N1103.2.2, N1103.2.3, and N1103.3 through N1103.9 and either:

1. Sections N1102.1 through N1102.3, N1103.2.1 and N1104.1; or
2. North Carolina specific REScheck shall be permitted to demonstrate compliance with this code. Envelope requirements may not be traded off against the use of high efficiency heating and/or cooling equipment. No trade-off calculations are needed for required termite inspection and treatment gaps.

**N1101.2.1 Warm humid counties.** Warm humid counties are identified in Table N1101.2 by an asterisk.

**N1101.2.2 Change in space conditioning.** Any nonconditioned space that is altered to become *conditioned space* shall be required to be brought into full compliance with this code.

**Exception:**

Existing enclosed ceiling, wall or floor cavities comply provided that these cavities are filled with insulation.

**N1101.3 Identification.** Materials, systems and equipment shall be identified in a manner that will allow a determination of compliance with the applicable provisions of this chapter.

**N1101.4 Building thermal envelope insulation.** An *R*-value identification mark shall be applied by the manufacturer to each piece of *building thermal envelope* insulation 12 inches (305 mm) or greater in width. Alternately, the insulation installers shall provide a certification listing the type, manufacturer and *R*-value of insulation installed in each element of the *building thermal envelope*. For blown or sprayed insulation (fiberglass and cellulose), the initial installed thickness, settled thickness, settled *R*-value, installed density, coverage area and number of bags installed shall be *listed* on the certification. For sprayed polyurethane foam (SPF) insulation, the installed thickness of the areas covered and *R*-value of installed thickness shall be *listed* on the certification. The insulation installer shall sign, date and post the certification in a conspicuous location on the job site.

**N1101.4.1 Blown or sprayed roof/ceiling insulation.** The thickness of blown-in or sprayed roof/ceiling insulation (fiberglass or cellulose) shall be written in inches (mm) on markers that are installed at least one for every 300 square feet (28 m<sup>2</sup>) throughout the attic space. The markers shall be affixed to the trusses or joists and marked with the minimum initial installed thickness with numbers a minimum of 1 inch (25 mm) in height. Each polyurethane foam thickness and installed *R*-value shall be *listed* on certification provided by the insulation installer.

**N1101.4.2 Insulation mark installation.** Insulating materials shall be installed such that the manufacturer's *R*-value mark is readily observable upon inspection.

**N1101.5 Fenestration product rating.** *U*-factors of fenestration products (windows, doors and skylights) shall be determined in accordance with NFRC 100 by an accredited, independent laboratory, and labeled and certified by the manufacturer. Products lacking such a labeled *U*-factor shall be assigned a default *U*-factor from Tables N1101.5(1) or N1101.5(2). The solar heat gain coefficient (SHGC) of glazed fenestration products (windows, glazed doors and skylights) shall be determined in accordance with

NFRC 200 by an accredited, independent laboratory, and labeled and certified by the manufacturer. Products lacking such a labeled SHGC shall be assigned a default SHGC from Table N1101.5(3).

**N1101.6 Insulation product rating.** The thermal resistance (*R*-value) of insulation shall be determined in accordance with the U.S. Federal Trade Commission *R*-value rule (CFR Title 16, Part 460, May 31, 2005) in units of h x ft<sup>2</sup> x °F/Btu at a mean temperature of 75°F (24°C).

**N1101.7 Installation.** All materials, systems and equipment shall be installed in accordance with the manufacturer's installation instructions and this code.

**N1101.7.1 Protection of exposed foundation insulation.** Insulation applied to the exterior of basement walls, crawlspace walls and the perimeter of slab-on-grade floors shall have a rigid, opaque and weather-resistant protective covering to prevent the degradation of the insulation's thermal performance. The protective covering shall cover the exposed exterior insulation and extend a minimum of 6 inches (153 mm) below grade.

**N1101.8 Above code programs.**  
Deleted

**N1101.9 Certificate.** A permanent certificate shall be posted on or in the electrical distribution panel, in the attic next to the attic insulation card, or inside a kitchen cabinet or other approved location. The certificate shall not cover or obstruct the visibility of the circuit directory label, service disconnect label or other required labels. The builder, permit holder, or registered design professional shall be responsible for completing the certificate. The certificate shall list the predominant *R*-values of insulation installed in or on ceiling/roof, walls, foundation (slab, *basement wall*, crawlspace wall and/or floor) and ducts outside conditioned spaces; *U*-factors for fenestration and the solar heat gain coefficient (SHGC) of fenestration. Where there is more than one value for each component, the certificate shall list the value covering the largest area. The certificate shall indicate whether the building air leakage was visually inspected as required in N1102.4.2.1 or provide results of the air leakage testing required in N1102.4.2.2 The certificate shall provide results of duct leakage test required in N1102.4.2.2. Appendix E-1 contains a sample certificate.

**TABLE N1101.2  
NORTH CAROLINA CLIMATE ZONES, MOISTURE REGIMES, AND WARM-HUMID DESIGNATIONS  
BY COUNTY**

**Key: A – Moist, B – Dry, C – Marine. Absence of moisture designation indicates moisture regime is irrelevant. Asterisk (\*) indicates a warm-humid location.**

**NORTH  
CAROLINA**

4A Alamance	3A Edgecombe	4A Orange
4A Alexander	4A Forsyth	3A Pamlico
5A Alleghany	4A Franklin	3A Pasquotank
3A Anson	3A Gaston	3A Pender*
5A Ashe	4A Gates	3A Perquimans
5A Avery	4A Graham	4A Person
3A Beaufort	4A Granville	3A Pitt
4A Bertie	3A Greene	4A Polk
3A Bladen	4A Guilford	3A Randolph
3A Brunswick*	4A Halifax	3A Richmond
4A Buncombe	4A Harnett	3A Robeson
4A Burke	4A Haywood	4A Rockingham
3A Cabarrus	4A Henderson	3A Rowan
4A Caldwell	4A Hertford	4A Rutherford
3A Camden	3A Hoke	3A Sampson
3A Carteret*	3A Hyde	3A Scotland
4A Caswell	4A Iredell	3A Stanly
4A Catawba	4A Jackson	4A Stokes
4A Chatham	3A Johnston	4A Surry
4A Cherokee	3A Jones	4A Swain
3A Chowan	4A Lee	4A Transylvania
4A Clay	3A Lenoir	3A Tyrrell
4A Cleveland	4A Lincoln	3A Union
3A Columbus*	4A Macon	4A Vance
3A Craven	4A Madison	4A Wake
3A Cumberland	3A Martin	4A Warren
3A Currituck	4A McDowell	3A Washington
3A Dare	3A Mecklenburg	5A Watauga
3A Davidson	5A Mitchell	3A Wayne
4A Davie	3A Montgomery	4A Wilkes
3A Duplin	3A Moore	3A Wilson
4A Durham	4A Nash	4A Yadkin
	3A New Hanover*	5A Yancey
	4A Northampton	
	3A Onslow*	

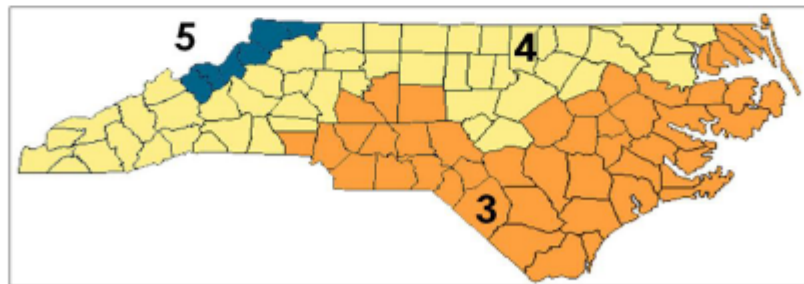

**Figure N1101.2(1) North Carolina Climate Zones**



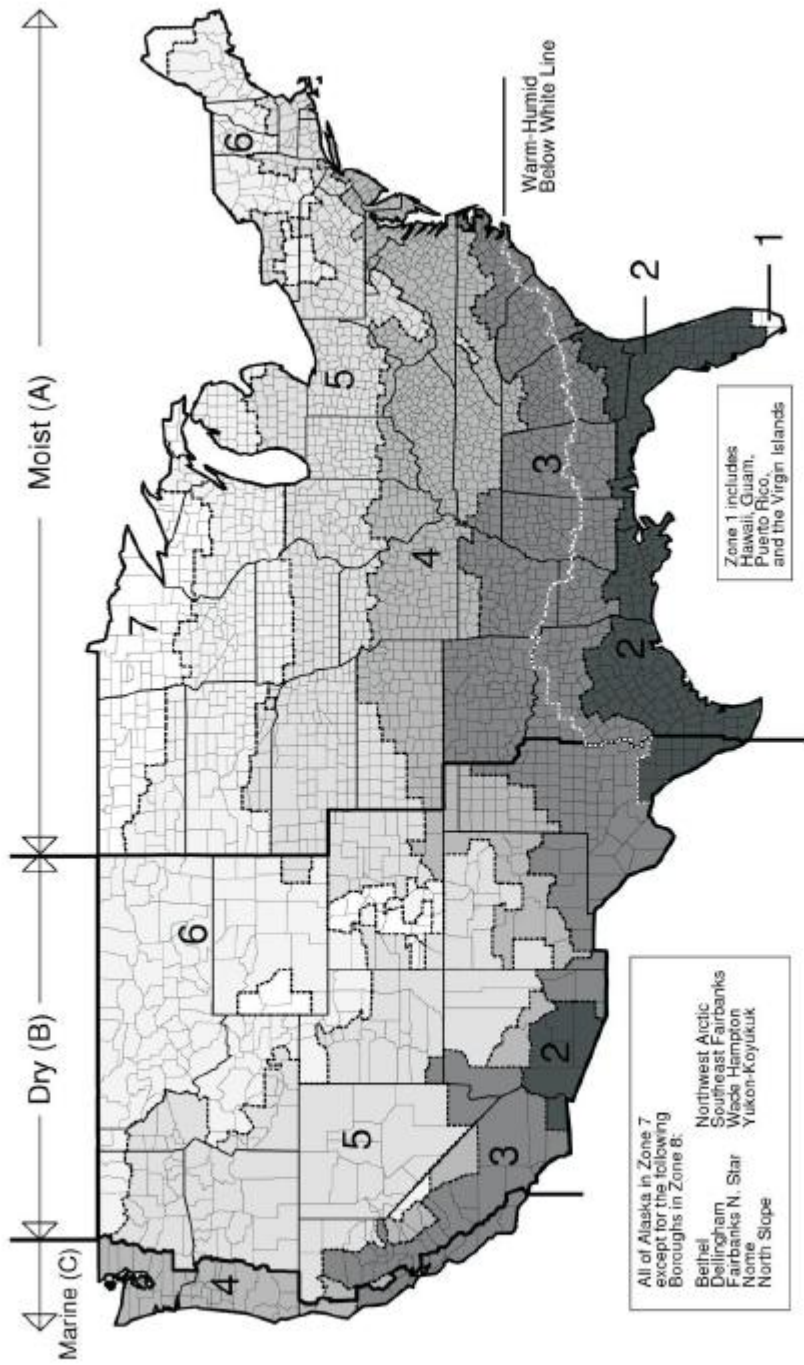

Figure N1101.2(2) Climate Zones

TABLE N1101.5(1)  
DEFAULT GLAZED FENESTRATION U-FACTOR

FRAME TYPE	SINGLE PANE	DOUBLE PANE	SKYLIGHT	
			Single	Double
Metal	1.20	0.80	2.00	1.30
Metal with Thermal Break	1.10	0.65	1.90	1.10
Nonmetal or Metal Clad	0.95	0.55	1.75	1.05
Glazed Block	0.60			

TABLE N1101.5(2)  
DEFAULT DOOR U-FACTORS

DOOR TYPE	U-FACTOR
Uninsulated Metal	1.20
Insulated Metal	0.60
Wood	0.50
Insulated, nonmetal edge, max 45% glazing, any glazing double pane	0.35

TABLE N1101.5(3)  
DEFAULT GLAZED FENESTRATION SHGC

SINGLE GLAZED		DOUBLE GLAZED		GLAZED BLOCK
Clear	Tinted	Clear	Tinted	
0.8	0.7	0.7	0.6	0.6

**SECTION N1102  
BUILDING THERMAL ENVELOPE**

**N1102.1 Insulation and fenestration criteria.** The *building thermal envelope* shall meet the requirements of Table N1102.1 based on the climate zone specified in Table N1101.2.

**N1102.1.1 R-value computation.** Insulation material used in layers, such as framing cavity insulation and insulating sheathing, shall be summed to compute the component R-value. The manufacturer's settled R-value shall be used for blown insulation. Computed R-values shall not include an R-value for other building materials or air films.

**N1102.1.2 U-factor alternative.** An assembly with a U-factor equal to or less than that specified in Table

N1102.1.2 shall be permitted as an alternative to the R-value in Table N1102.1.

**N1102.1.3 Total UA alternative.** If the total *building thermal envelope* UA (sum of U-factor times assembly area) is less than or equal to the total UA resulting from using the U-factors in Table N1102.1.2 (multiplied by the same assembly area as in the proposed building), the building shall be considered in compliance with Table N1102.1. The UA calculation shall be done using a method consistent with the ASHRAE *Handbook of Fundamentals* and shall include the thermal bridging effects of framing materials. The SHGC requirements shall be met in addition to UA compliance.

**TABLE N1102.1  
INSULATION AND FENESTRATION REQUIREMENTS BY COMPONENT<sup>a</sup>**

CLIMATE ZONE	FENESTRATION U-FACTOR <sup>b</sup>	SKYLIGHT <sup>b</sup> U-FACTOR	GLAZED FENESTRATION SHGC <sup>b,c</sup>	CEILING R-VALUE <sup>k</sup>	WOOD FRAME WALL R-VALUE <sup>e</sup>	MASS WALL R-VALUE <sup>i</sup>	FLOOR R-VALUE	BASEMENT <sup>c</sup> WALL R-VALUE	SLAB <sup>j</sup> R-VALUE & DEPTH	CRAWL SPACE <sup>c</sup> WALL R-VALUE
3	0.32 <sup>j</sup>	0.65	0.27	42	19, 13+5, or 15+3 <sup>eh</sup>	5/10	19	10/13 <sup>r</sup>	5, 2 ft	10/13
4	0.32	0.60	0.27	42	19, 13+5, or 15+3 <sup>eh</sup>	5/10	19	10/13	10, 2 ft	10/13
5	0.32	0.60	NR	42	19, 13+5, or 15+3 <sup>eh</sup>	13/17	30 <sup>g</sup>	10/13	10, 2 ft	15/19

For SI: 1 foot = 304.8 mm.

a. R-values are minimums. U-factors and SHGC are maximums.

b. The fenestration U-factor column excludes skylights. The SHGC column applies to all glazed fenestration.

c. "10/13" means R-10 continuous insulated sheathing on the interior or exterior of the home or R-13 cavity insulation at the interior of the basement wall or crawl space wall.

d. For monolithic slabs, insulation shall be applied from the inspection gap downward to the bottom of the footing. For floating slabs, insulation shall extend to the bottom of the foundation wall or 24 inches, whichever is less. (See Appendix O) R-5 shall be added to the required slab edge R-values for heated slabs.

e. R-19 fiberglass batts compressed and installed in a nominal 2 x 6 framing cavity is deemed to comply. Fiberglass batts rated R-19 or higher compressed and installed in a 2x4 wall is not deemed to comply.

f. Basement wall insulation is not required in warm-humid locations as defined by Figure N1101.2(1 and 2) and Table N1101.2.

g. Or insulation sufficient to fill the framing cavity, R-19 minimum.

h. "13+5" means R-13 cavity insulation plus R-5 insulated sheathing. 15+3 means R-15 cavity insulation plus R-3 insulated sheathing. If structural sheathing covers 25 percent or less of the exterior, insulating sheathing is not required where structural sheathing is used. If structural sheathing covers more than 25 percent of exterior, structural sheathing shall be supplemented with insulated sheathing of at least R-2.

i. For Mass Walls, the second R-value applies when more than half the insulation is on the interior of the mass wall.

j. Where impact rated fenestration is used, the maximum U-factor shall be 0.40.

k. Table value required except for roof edge where the space is limited by the pitch of the roof, there the insulation must fill the space up to the air baffle.

## N1102.2 Specific insulation requirements

**N1102.2.1 Ceilings with attic spaces.** Attics with continuous uncompressed R-38, including over the wall top plates at the eaves, shall be deemed to satisfy the requirement for R-42. This reduction shall not apply to the *U*-factor alternative approach in Section N1102.1.2 and the total UA alternative in Section N1102.1.3. Otherwise, R-42 is required, except for roof edge and other miscellaneous details such as bay windows, dormers, and similar areas where the space is limited; there the insulation must fill the space up to the air baffle.

**Exception:** When insulation is installed in a *fully enclosed attic floor system*, as described in Appendix E 2.1, R-30 shall be deemed compliant.

**N1102.2.2 Ceilings without attic spaces.** Where the design of the roof/ceiling assembly, including cathedral ceilings, bay windows and other miscellaneous areas, does not allow sufficient space for the required insulation, the minimum required insulation for such roof/ceiling assemblies shall be R-30. This reduction of insulation from the requirements of Section N1102.1 shall be limited to 500 square feet (46m<sup>2</sup>) of ceiling surface area. This reduction shall not apply to the *U*-factor alternative approach in Section N1102.1.2 and the total UA alternative in Section N1102.1.3.

**N1102.2.3 Access hatches and doors.** Access doors from *conditioned spaces* to unconditioned spaces (e.g., attics and crawl spaces) shall be weatherstripped and insulated to an R-10 minimum value. Access shall be provided to all *equipment* that prevents damaging or compressing the insulation. A wood framed or equivalent baffle or retainer is required to be provided when loose fill insulation is installed, the purpose of which is to prevent the loose fill insulation from spilling into the living space when the attic access is opened, and to provide a permanent means of maintaining the installed *R*-value of the loose fill insulation.

**Exceptions:** 1) Pull down stair systems shall be weatherstripped and insulated to an R-5 insulation value. Non-rigid insulation materials are not allowed. Additional insulation systems that enclose the stair system from above are allowed. Exposed foam plastic must meet the provisions of the North Carolina Residential Code.

2) Full size doors that are part of the building thermal envelope and provide a passageway to unconditioned spaces shall meet the requirements of exterior doors in Section N1102.3.4.

**N1102.2.4 Mass walls.** Mass walls for the purposes of this chapter shall be considered above-grade walls of concrete block, concrete, insulated concrete form (ICF), masonry cavity, brick (other than brick veneer), earth (adobe, compressed earth block, rammed earth) and solid timber/logs.

**N1102.2.5 Steel-frame ceilings, walls, and floors.** Steel-frame ceilings, walls and floors shall meet the insulation requirements of Table N1102.2.5 or shall meet the *U*-factor requirements in Table N1102.1.2. The calculation of the *U*-factor for a steel-frame envelope assembly shall use a series-parallel path calculation method.

**N1102.2.6 Floors.** Floor insulation shall be installed to maintain permanent contact with the underside of the subfloor decking. The distance between tension support wires or other devices that hold the floor insulation in place against the subfloor shall be no more than 18 inches. In addition, supports shall be located no further than 6 inches from each end of the insulation.

**Exception:** Enclosed floor cavity such as garage ceilings, cantilevers or buildings on pilings with enclosed floor cavity with the insulation fully in contact with the lower air barrier. In this case, the band boards shall be fully insulated to maintain thermal envelope continuity.

**N1102.2.7 Basement walls.** Walls associated with conditioned basements shall be insulated from the top of the *basement wall* down to 10 feet (3048 mm) below *grade* or to the basement floor, whichever is less. Walls associated with unconditioned basements shall meet this requirement unless the floor overhead is insulated in accordance with Sections N1102.1 and N1102.2.6.

**N1102.2.8 Slab-on-grade floors.** Slab-on-grade floors with a floor surface less than 12 inches (305 mm) below grade shall be insulated in accordance with Table N1102.1. The top edge of the insulation installed between the *exterior wall* and the edge of the interior slab shall be permitted to be cut at a 45-

degree (0.79 rad) angle away from the *exterior wall*. Slab edge insulation shall have 2" termite inspection gap consistent with Appendix O of this code.

**TABLE N1102.1.2  
EQUIVALENT U-FACTORS<sup>a</sup>**

CLIMATE ZONE	FENESTRATION U-FACTOR	SKYLIGHT U-FACTOR	CEILING U-FACTOR	FRAME WALL U-FACTOR	MASS WALL U-FACTOR <sup>b</sup>	FLOOR U-FACTOR	BASEMENT WALL U-FACTOR <sup>d</sup>	CRAWL SPACE WALL U-FACTOR <sup>c</sup>
3	0.32	0.65	0.030	0.067	0.141	0.047	0.059	0.065
4	0.32	0.60	0.030	0.067	0.141	0.047	0.059	0.065
5	0.32	0.60	0.030	0.067	0.082	0.033	0.059	0.046

a. Nonfenestration *U*-factors shall be obtained from measurement, calculation or an approved source.

b. When more than half the insulation is on the interior, the mass wall *U*-factors shall be a maximum 0.12 in Zone 3, 0.10 in Zone 4, and the same as the frame wall *U*-factor in Zone 5.

c. Basement wall *U*-factor of 0.360 in warm-humid locations as defined by Figures N1101.2(1), N1101.2(2) and Table N1101.2.

d. Foundation *U*-factor requirements shown in Table N1102.1.2 include wall construction and interior air films but exclude soil conductivity and exterior air films. *U*-factors for determining code compliance in accordance with Section N1102.1.3 (total UA alternative) shall be modified to include soil conductivity and exterior air films.

**TABLE N1102.2.5  
STEEL-FRAME CEILING, WALL AND FLOOR INSULATION (R-VALUE)**

WOOD FRAME R-VALUE REQUIREMENT	COLD-FORMED STEEL EQUIVALENT R-VALUE <sup>a</sup>
<b>Steel Truss Ceilings<sup>b</sup></b>	
R-42	R-49 or R-38 + 3
<b>Steel Joist Ceilings<sup>b</sup></b>	
R-42	R-49 in 2 x 4 or 2 x 6 or 2 x 8 or 2 x 10
<b>Steel-Framed Wall</b>	
R-19	R-13 + R-9 or R-19 + R8 or R-25 + R7
<b>Steel Joist Floor</b>	
R-19	R-19 + R-6 in 2 x 6 R-19 + R-12 in 2 x 8 or 2 x 10
R-30	R-30 + R-4 in 2 x 8 or 2 x 10

a. Cavity insulation *R*-value is listed first, followed by continuous insulation *R*-value.

b. Insulation exceeding the height of the framing shall cover the framing.

**N1102.2.9 Closed Crawl space walls.**

Where the floor above a closed crawl space is not insulated, the exterior crawlspace walls shall be insulated in accordance with table 1102.1.

Wall insulation may be located in any combination of the outside and inside wall surfaces and within the structural cavities or materials of the wall system.

Wall insulation requires that the exterior wall band joist area of the floor frame be insulated. Wall insulation shall begin 3 inches (76.2mm) below the top of the masonry foundation wall and shall extend down to 3 inches (76.2mm) above the top of the footing or concrete floor, 3 inches(76.2mm ) above the interior ground surface or 24 inches (609.6mm) below the outside finished ground level, whichever is less. (See Appendix E-2.2 details)

Termite inspection, clearance, and wicking gaps are allowed in wall insulation systems. Insulation may be omitted in the gap area without energy penalty.

The allowable insulation gap widths are listed in Table N1102.2.9. If gap width exceeds the allowances, one of the following energy compliance options shall be met:

1. Wall insulation is not allowed and the required insulation value shall be provided in the floor system.

2. Compliance shall be demonstrated with energy trade-off methods provided by a North Carolina-specific version of RESCHECK

TABLE N1102.2.9  
WALL INSULATION ALLOWANCES FOR TERMITE  
TREATMENT AND INSULATION GAPS

Maximum Gap Width(inches)	Insulation Location	Gap Description
3	Outside	Above grade inspection between top of insulation and bottom of siding
6	Outside	Below grade treatment
4a	Inside	Wall inspection between top of insulation and bottom of sill
4a	Inside	Clearance / wicking space between bottom of insulation and top of ground surface, footing, or concrete floor.

For si 1 inch = 25.4mm

a. No insulation shall be required on masonry wall of 9 inches in height or less.

**N1102.2.10 Masonry veneer.** Insulation shall not be required on the horizontal portion of the foundation that supports a masonry veneer.

**N1102.2.11 Thermally isolated conditioned sunroom insulation.** The minimum ceiling insulation *R*-values shall be R-24. The minimum wall *R*-value shall be R-13. New wall(s) separating a sunroom from *conditioned space* shall meet the *building thermal envelope* requirements. Floor and slab insulation shall comply with values in Table N1102.1.1.

**N1102.2.12 Framed cavity walls.** The exterior thermal envelope wall insulation shall be installed in substantial contact and continuous alignment with the building envelope air barrier. Insulation shall be substantially free from installation gaps, voids, or compression. For framed walls, the cavity insulation shall be enclosed on all sides with rigid material. Wall insulation shall be enclosed at the following locations when installed on exterior walls prior to being covered by subsequent construction, consistent with the Appendix E-2.3 of this code:

1. Tubs
2. Showers
3. Stairs
4. Fireplace units

Enclosure of wall cavity insulation also applies to walls that adjoin attic spaces by placing an approved rigid material on the attic space side of the wall.

### N1102.3 Fenestration.

**N1102.3.1 *U*-factor.** An area-weighted average of fenestration products shall be permitted to satisfy the *U*-factor requirements.

**N1102.3.2 Glazed fenestration SHGC.** An area-weighted average of fenestration products more than 50 percent glazed shall be permitted to satisfy the SHGC requirements.

**N1102.3.3 Glazed fenestration exemption.** Up to 15 square feet (1.4m<sup>2</sup>) of glazed fenestration per dwelling unit shall be permitted to be exempt from *U*-factor and SHGC requirements in Section N1102.1. This exemption shall not apply to the *U*-factor alternative approach in Section N1102.1.2 and the Total UA alternative in Section N1102.1.3.

**N1102.3.4 Opaque door.** Opaque doors separating conditioned and unconditioned space shall have a maximum *U*-factor of 0.35.

**Exception:** One side-hinged opaque door assembly up to 24 square feet (2.22 m<sup>2</sup>) in area is exempted from the *U*-factor requirement in Section N1102.1. This exemption shall not apply to the *U*-factor alternative approach in Section N1102.1.2 and the Total UA alternative in Section N1102.1.3.

**N1102.3.5 Thermally isolated conditioned sunroom *U*-factor and SHGC.** The maximum fenestration *U*-factor shall be 0.40 and the maximum skylight *U*-Factor shall be 0.75. Sunrooms with cooling systems shall have a maximum fenestration SHGC of 0.40 for all glazing.

New windows and doors separating the sunroom from conditioned space shall meet the building thermal envelope requirements. Sunroom additions shall maintain thermal isolation; and shall be served by a separate heating or cooling system, or be thermostatically controlled as a separate zone of the existing system.

**N1102.3.6 Replacement fenestration.** Where an entire existing fenestration unit is replaced with a new fenestration product, including frame, sash and glazing, the replacement fenestration unit shall meet the applicable requirements for *U*-factor and SHGC in Table N1102.1.

### N1102.4 Air leakage control

**N1102.4.1 Building thermal envelope.** The *building thermal envelope* shall be durably sealed with an air barrier system to limit infiltration. The sealing methods between dissimilar materials shall allow for differential expansion and contraction. For all homes, where present, the following shall be caulked,

gasketed, weatherstripped or otherwise sealed with an air barrier material or solid material consistent with Appendix E-2.4 of this code:

1. Blocking and sealing floor/ceiling systems and under knee walls open to unconditioned or exterior space.
2. Capping and sealing shafts or chases, including flue shafts.
3. Capping and sealing soffit or dropped ceiling areas.
4. Sealing HVAC register boots and return boxes to subfloor or drywall.

**N1102.4.2 Air sealing.** Building envelope air tightness shall be demonstrated by Section N1102.4.2.1 or N1102.4.2.2. Appendix E-3 contains optional sample worksheets for visual inspection or testing for the permit holder's use only.

**N1102.4.2.1 Visual inspection option.** Building envelope tightness shall be considered acceptable when items providing insulation enclosure in N1102.2.12 and air sealing in N1102.4.1 are addressed and when the items listed in Table N1102.4.2, applicable to the method of construction, are certified by the builder, permit holder or registered design professional via the certificate in Appendix E-1.

**N1102.4.2.2 Testing option.** Building envelope tightness shall be considered acceptable when items providing insulation enclosure in N1102.2.12 and air sealing in N1102.4.1 are addressed and when tested air leakage is less than or equal to one of the two following performance measurements:

1. 0.24 CFM50/Square Foot of Surface Area (SFSA) or
2. Four (4) air changes per hour (ACH50)

when tested with a blower door fan assembly, at a pressure of 33.5 psf (50 Pa). A single point depressurization, not temperature corrected, test is sufficient to comply with this provision, provided that the blower door fan assembly has been certified by the manufacturer to be capable of conducting tests in accordance with ASTM E779-03. Testing shall occur after rough in and after installation of penetrations of the building envelope, including penetrations for utilities, plumbing, electrical, ventilation and combustion appliances. Testing shall

be reported by the permit holder, a NC licensed general contractor, a NC licensed HVAC contractor, a NC licensed Home Inspector, a registered design professional, a *certified BPI Envelope Professional* or a *certified HERS rater*.

During testing:

1. Exterior windows and doors, fireplace and stove doors shall be closed, but not sealed;
2. Dampers shall be closed, but not sealed, including exhaust, backdraft, and flue dampers;
3. Interior doors shall be open;
4. Exterior openings for continuous ventilation systems, air intake ducted to the return side of the conditioning system, and energy or heat recovery ventilators shall be closed and sealed;
5. Heating and cooling system(s) shall be turned off, and
6. Supply and return registers shall not be sealed.

The air leakage information, including building air leakage result, tester name, date, and contact information, shall be included on the certificate described in Section N1101.9.

For Test Criteria 1 above, the report shall be produced in the following manner: perform the blower door test and record the *CFM50*. Calculate the total square feet of surface area for the building thermal envelope (all floors, ceilings, and walls, including windows and doors, bounding conditioned space) and record the area. Divide *CFM50* by the total square feet and record the result. If the result is less than or equal to [0.24 CFM50/SFSA] the envelope tightness is acceptable; or

For Test Criteria 2 above, the report shall be produced in the following manner: Perform a blower door test and record the *CFM50*. Multiply the *CFM50* by 60 minutes to create *CFHour50* and record. Then calculate the total conditioned volume of the home and record. Divide the *CFHour50* by the total volume and record the result. If the result is less than or equal to [4 ACH50] the envelope tightness is acceptable

**TABLE N1102.4.2  
AIR BARRIER INSPECTION**

COMPONENT	CRITERIA
Ceiling/attic	Sealants or gaskets provide a continuous air barrier system joining the top plate of framed walls with either the ceiling drywall or the top edge of wall drywall to prevent air leakage. Top plate penetrations are sealed.  For ceiling finishes that are not air barrier systems such as tongue-and-groove planks, air barrier systems,(for example, taped house wrap), shall be used above the finish  Note: It is acceptable that sealants or gaskets applied as part of the application of the drywall will not be observable by the code official
Walls	Sill plate is gasketed or sealed to subfloor or slab.
Windows and doors	Space between window and exterior door jambs and framing is sealed.
Floors (including above-garage and cantilevered floors)	Air barrier system is installed at any exposed edge of insulation.
Penetrations	Utility penetrations through the building thermal envelope, including those for plumbing, electrical wiring, ductwork, security and fire alarm wiring, and control wiring, shall be sealed.
Garage separation	Air sealing is provided between the garage and conditioned spaces. An air barrier system shall be installed between the ceiling system above the garage and the ceiling system of interior spaces.
Recessed lighting	Recessed light fixtures are air tight, IC rated, and sealed to drywall. <b>Exception</b> —fixtures not penetrating the building envelope.

**N1102.4.3 Fireplaces.** Solid fuel-burning fireplaces shall have doors and comply with Section M1006 of the North Carolina Residential Code for combustion air.

**N1102.4.4 Fenestration air leakage.** Windows, skylights and sliding glass doors shall have an air infiltration rate of no more than 0.3 cfm per square foot (1.5 L/s/m<sup>2</sup>), and swinging doors no more than 0.5 cfm per square foot (2.6 L/s/m<sup>2</sup>), when tested according to NFRC 400 or AAMA/WDMA/CSA 101/I.S.2/A440 by an accredited, independent laboratory and *listed and labeled* by the manufacturer.

**Exception:** Site-built windows, skylights and doors.

**N1102.4.5 Recessed lighting.** Recessed luminaires installed in the *building thermal envelope* shall be sealed to limit air leakage between conditioned and unconditioned spaces. All recessed luminaires shall be IC-rated and *labeled* as meeting ASTM E 283 when tested at 1.57 psf (75 Pa) pressure differential with no more than 2.0 cfm (0.944 L/s) of air movement from the *conditioned space* to the ceiling cavity. All recessed luminaires shall be sealed with a gasket or caulk between the housing and the interior wall or ceiling covering.

**N1102.5 Maximum fenestration U-factor and SHGC**

The area-weighted average maximum fenestration U-factor permitted using trade-offs from Section 1102.1.4 shall be 0.40. Maximum skylight U-factors shall be 0.65 in zones 4 and 5 and 0.60 in zone 3.

**SECTION N1103  
SYSTEMS**

**N1103.1 Controls.** At least one thermostat shall be provided for each separate heating and cooling system.

**N1103.1.1 Programmable thermostat.** Where the primary heating system is a forced-air furnace, at least one thermostat per dwelling unit shall be capable of controlling the heating and cooling system on a daily schedule to maintain different temperature set points at different times of the day. This thermostat shall include the capability to set back or temporarily operate the system to maintain zone temperatures down to 55°F (13°C) or up to 85°F (29°C).

**N1103.1.2 Heat pump supplementary heat.** Heat pumps having supplementary electric-resistance heat shall have controls that, except during defrost, prevent supplemental heat operation when the heat pump compressor can meet the heating load.



A heat strip outdoor temperature lockout shall be provided to prevent supplemental heat operation in response to the thermostat being changed to a warmer setting. The lockout shall be set no lower than 35°F and no higher than 40°F.

**N1103.1.3 Maintenance information.** Maintenance instructions shall be furnished for equipment and systems that require preventive maintenance. Required regular maintenance actions shall be clearly stated and incorporated on a readily accessible label. The label shall include the title or publication number for the operation and maintenance manual for that particular model and type of product.

### N1103.2 Ducts.

**N1103.2.1 Insulation.** Supply and return ducts in unconditioned space and outdoors shall be insulated to R-8. Supply ducts inside semiconditioned space shall be insulated to R-4; return ducts inside conditioned and semi-conditioned space are not required to be insulated. Ducts located inside conditioned space are not required to be insulated other than as may be necessary for preventing the formation of condensation on the exterior of cooling ducts.

**N1103.2.2 Sealing** All ducts, air handlers, filter boxes and building cavities used as ducts shall be sealed. Joints and seams shall comply with Section 603.9 of the *NC Mechanical Code*.

**Exception to sealing requirements:**  
Systems where air handler and all ducts are located within conditioned space and exposed within the space (not hidden within walls or ceiling/floor systems).

Duct tightness shall be verified as follows:

Total duct leakage less than or equal to 4 CFM (12 L/min) per 100 ft<sup>2</sup> (9.29 m<sup>2</sup>) of *conditioned floor area* served by that system when tested at a pressure differential of 0.1 inches w.g. (25 Pa) across the entire system, including the manufacturer's air handler enclosure.

During testing:

1. Block, if present, the ventilation air duct connected to the conditioning system.
2. The duct air leakage testing equipment shall be attached to the largest return in the system or to the air handler.

3. The filter shall be removed and the air handler power shall be turned off.

3. Supply boots or registers and return boxes or grilles shall be taped, plugged, or otherwise sealed air tight.

4. The hose for measuring the 25 Pascals of pressure differential shall be inserted into the boot of the supply that is nominally closest to the air handler.

5. Specific instructions from the duct testing equipment manufacturer shall be followed to reach duct test pressure and measure duct air leakage.

Testing shall be performed and reported by the permit holder, a NC licensed general contractor, a NC licensed HVAC contractor, a NC licensed Home Inspector, a registered design professional, a certified BPI Envelope Professional or a certified HERS rater. A single point depressurization, not temperature corrected, test is sufficient to comply with this provision, provided that the duct testing fan assembly has been certified by the manufacturer to be capable of conducting tests in accordance with ASTM E1554-07.

The duct leakage information, including duct leakage result, tester name, date, and contact information, shall be included on the certificate described in Section N1101.9.

For the Test Criteria, the report shall be produced in the following manner: perform the HVAC system air leakage test and record the CFM25. Calculate the total square feet of Conditioned Floor Area (CFA) served by that system. Divide the Conditioned Floor Area by 100 to provide the number of CFA100. Divide the CFM25 by the number of CFA100 and record the result. If the result is less than or equal to [4 CFM25/100 SF] the HVAC system air tightness is acceptable. Appendix E-3C contains optional sample worksheets for duct testing for the permit holder's use only.

#### Exceptions to testing requirements:

1. Systems where air handler and all ducts are located within conditioned space.
2. Installation of a partial system as part of replacement, renovation or addition does not require a duct leakage test.

**N1103.2.3 Building cavities.** Building framing cavities shall not be used as supply ducts.

**N1103.3 Mechanical system piping insulation.**

Mechanical system piping capable of carrying fluids above 105°F (41°C) or below 55°F (13°C) shall be insulated to a minimum of R-3.

**N1103.4 Circulating hot water systems.** All circulating service hot water piping shall be insulated to at least R-2. Circulating hot water systems shall include an automatic or readily *accessible* manual switch that can turn off the hot water circulating pump when the system is not in use.

**N1103.5 Mechanical ventilation.** Exhausts shall have automatic or gravity dampers that close when the ventilation system is not operating.

**N1103.6 Equipment sizing and efficiency.**

**N1103.6.1 Equipment Sizing.** Heating and cooling equipment shall be sized in accordance with the mechanical section of the North Carolina Residential Code.

**N1103.6.2 Equipment Efficiencies.** Equipment efficiencies shall comply with the current NAECA minimum standards.

**N1103.7 Snow melt system controls.** Snow- and ice-melting systems, supplied through energy service to the building, shall include automatic controls capable of shutting off the system when the pavement temperature is above 50°F, and no precipitation is falling and an automatic or manual control that will allow shutoff when the outdoor temperature is above 40°F.

**N1103.8 Pools.** Pools shall be provided with energy-conserving measures in accordance with Sections N1103.8.1 through N1103.8.3.

**N1103.8.1 Pool heaters.** All pool heaters shall be equipped with a readily *accessible* on-off switch to allow shutting off the heater without adjusting the thermostat setting. Pool heaters fired by natural gas shall not have continuously burning pilot lights.

**N1103.8.2 Time switches.** Time switches that can automatically turn off and on heaters and pumps according to a preset schedule shall be installed on swimming pool heaters and pumps.

**Exceptions:**

1. Where public health standards require 24-hour pump operation.
2. Where pumps are required to operate solar- and waste-heat-recovery pool heating systems.

**N1103.8.3 Pool covers.** Heated pools shall be equipped with a vapor-retardant pool cover on or at the water surface. Pools heated to more than 90°F (32°C) shall have a pool cover with a minimum insulation value of R-12.

**Exception:** Pools deriving over 60 percent of the energy for heating from site-recovered energy or solar energy source.

**SECTION N1104  
LIGHTING SYSTEMS**

**N1104.1 Lighting equipment.** A minimum of 75 percent of the lamps in permanently installed lighting fixtures shall be *high-efficacy Lamps*.

# Chapter 44 Reference Standards

## Changes/additions:

<b>ASHRAE</b>	American Society of Heating, Refrigerating and Air-Conditioning Engineers, Inc. 1791 Tullie Circle, NE Atlanta, GA 30329-2305	
Standard reference number	Title	Referenced in code section number
<u>ASHRAE—2005</u>	<u>ASHRAE Handbook of Fundamentals</u>	<u>N1102.1.3</u>

<b>ASTM</b>	ASTM International 100 Barr Harbor Drive West Conshohocken, PA 19428-2859	
Standard reference number	Title	Referenced in code section number
E 283—04	Test Method for Determining the Rate of Air Leakage Through Exterior Windows, Curtain Walls and Doors Under Specified Pressure Differences Across the Specimen	<u>N1102.4.5</u>

<b>CSA</b>	Canadian Standards Association 5060 Spectrum Way Mississauga, Ontario, Canada L4W 5N6	
Standard reference number	Title	Referenced in code section number
<u>101/I.S.2/A440—08</u>	<u>Specifications for Windows, Doors and Unit Skylights.</u>	<u>N1102.4.4</u>

<b>ICC</b>	International Code Council, Inc. 500 New Jersey Avenue, NW 6th Floor Washington, DC 20001	
Standard reference number	Title	Referenced in code section number
IRC—09	International Residential Code*	<u>N1102.2.3, N1103.6</u>

<b>US—FTC</b>	<u>United States - Federal Trade Commission</u> <u>600 Pennsylvania Avenue NW</u> <u>Washington, DC 20580</u>	
Standard reference number	Title	Referenced in code section number
<u>CFR Title 16</u>	<u>R-value Rule</u>	<u>N1101.6</u>

# Chapter 45 High Wind Zones

Leave as listed in NC 2009 Code but change section references (this is a change to all sections by listing R reference in front of each item and all of chapter 44 become chapter 45). Change under title the reference to IRC should be: “This chapter is a North Carolina section, there will be no underlined text”.

**R4501.1 General** The provisions of this chapter shall be applicable to buildings constructed in high wind zones as noted by the text. These provisions shall be in addition to or in lieu of previous chapters.

**R4505.1** Exterior walls of wood frame construction shall be in accordance with Figures R602.3 (1) and R602.3 (2). Components of exterior walls shall be fastened in accordance with Table R602.3 (1). Walls of wood frame construction shall be designed and constructed in accordance with AF&PA NFPA “National Design Specifications for Wood Construction,” listed in Chapter 43.

**R4501.2** R4501.2 Alternate construction. In lieu of specific code requirements for structures in the 110, 120, and 130 miles per hour wind (48 m/s, 53 m/s and 57m/s) zones, compliance with International Code Council ICC 600-2008 Standard for Residential Construction in High-Wind Regions or AF&PA Wood Frame

## Chapter 46 Coastal and Flood Plain Standards

Leave as listed in the NC 2009 Code but change section references (this is a change to all sections by listing R reference in front of each item and all of chapter 45 become chapter 46). Change under title to read: "This chapter is a North Carolina section, there will be no underlined text".

**R4603.7** Change the reference from R319 to "in accordance with AWPA U1".

**R4605.7 Roof covering** Delete

## Appendix

**Appendix E** Delete and replace as an energy conservation appendix with items below:

### APPENDIX E-1: RESIDENTIAL REQUIREMENTS

#### Energy Efficiency Certificate (Section N1101.9)

<b>ENERGY EFFICIENCY CERTIFICATE</b>	
N1101.9	
Builder or Registered Design Professional Name:	
Property Address:	
Date:	
Insulation Rating - List the value covering largest area to all that apply	R-Value
Ceiling/roof:	R-
Wall:	R-
Floor:	R-
Closed Crawl Space Wall:	R-
Closed Crawl Space Floor:	R-
Slab:	R-
Basement Wall:	R-
Fenestration:	
U-Factor	R-
Solar Heat Gain Coefficient(SHGC)	R-
Building Air Leakage	
<input type="checkbox"/> Visually inspected according to N1102.4.2.1 OR	
<input type="checkbox"/> Building Air Leakage Test Results (Sect. N1102.4.2.2) ACH50 [Target: 4.0] or CFM50/SFSA [Target: 0.24]	R-
Name/Certification:	
Date:	
Phone:	
Ducts:	
Insulation	R-
Total Duct Leakage Test Result (Sect. N1103.2.2) (CFM25 Total/100SF) [Target: 4]	R-
Name/Certification:	
Date:	
Phone:	

**APPENDIX E-2  
INSULATION AND AIR SEALING DETAILS**

**APPENDIX E-2.1**

**N1102.2.1 Ceilings with attic spaces:** Exception for fully enclosed attic floor systems

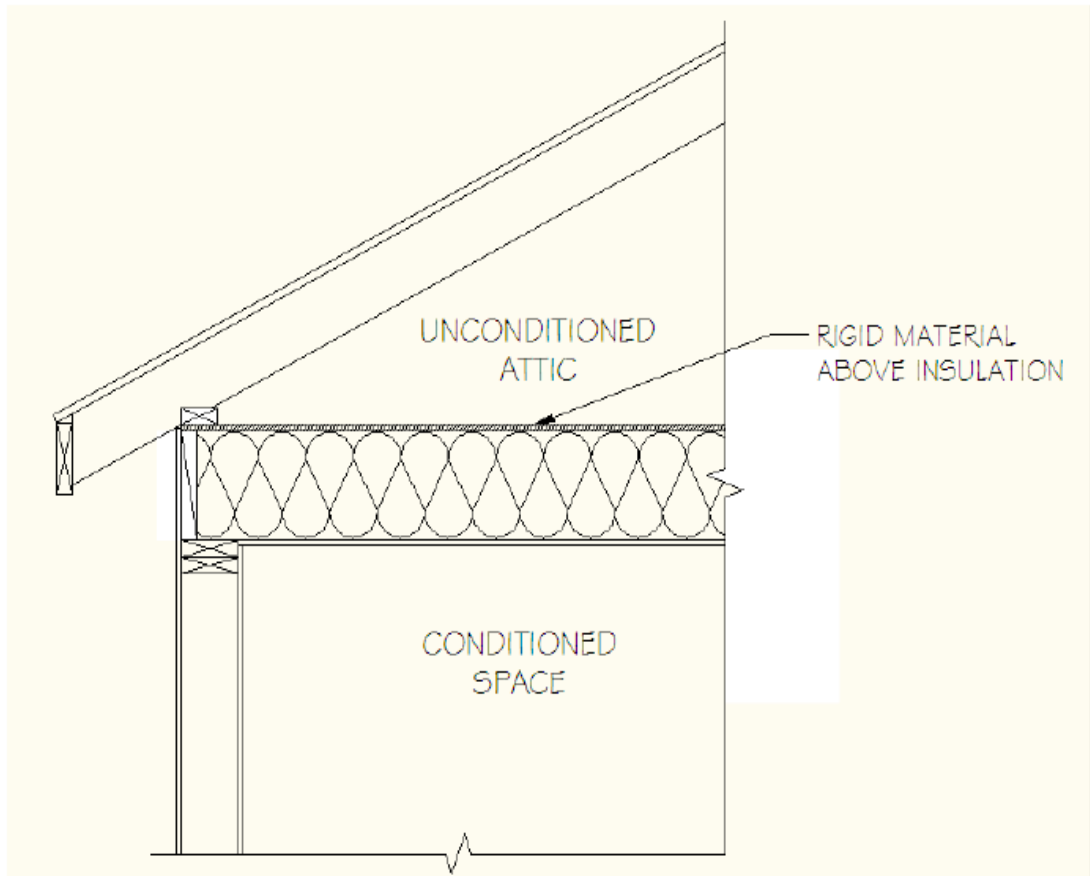

**SECTION VIEW OF CEILING WITH ATTIC SPACE**

## APPENDIX E-2.2

### N1102.2.9 Closed crawl space walls. Insulation illustrations

Foam or porous insulation has 3" top inspection gap and extends down 3" above top of wall footing or concrete floor

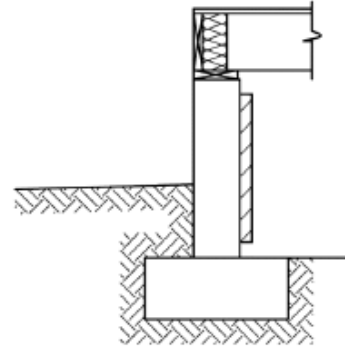

Foam or porous insulation has 3" top inspection gap and extends down 3" above interior ground surface

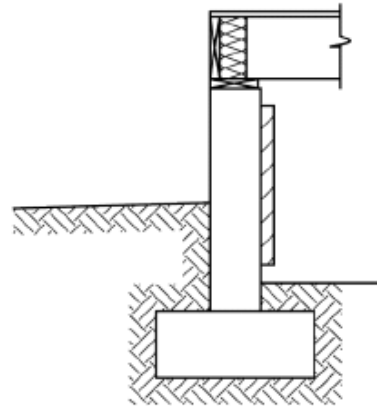

Foam or porous insulation has 3" top inspection gap and extends down 24" below grade

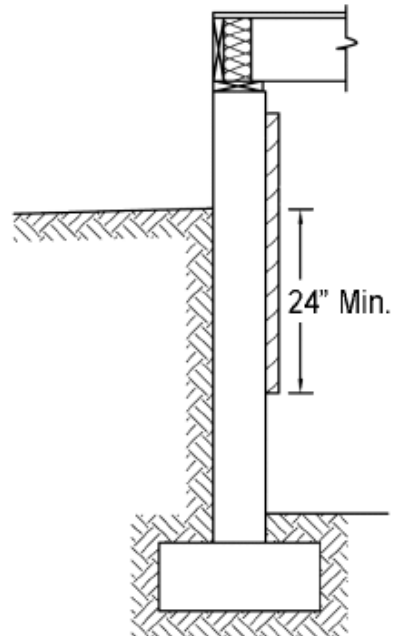

**APPENDIX E-2.3**

**N1102.2.12 Framed cavity walls. Insulation enclosure – 1. Tubs**

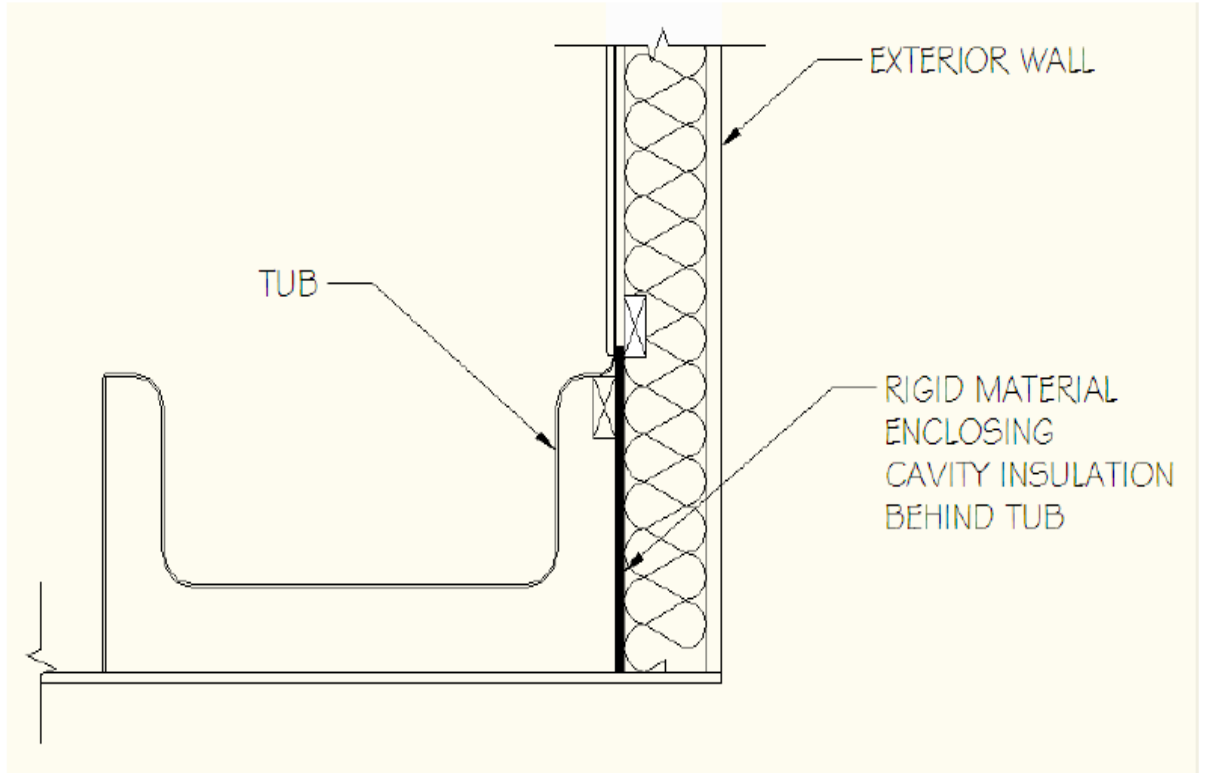

**SECTION VIEW OF BATH TUB ON EXTERIOR WALL**

**N1102.2.12 Framed cavity walls. Insulation enclosure – 2. Showers**

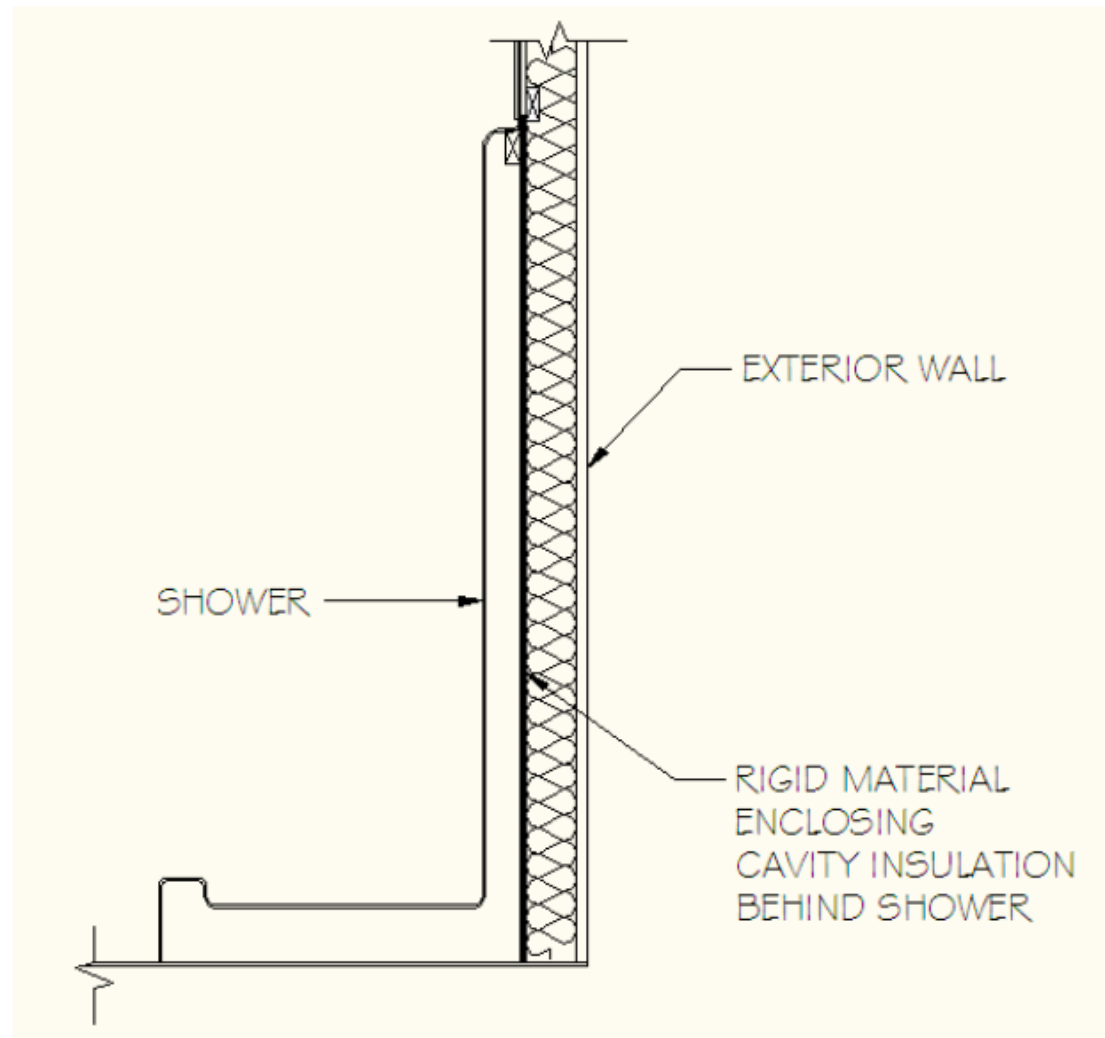

**SECTION VIEW OF SHOWER ON EXTERIOR WALL**



**N1102.2.12 Framed cavity walls. Insulation enclosure – 3. Stairs**

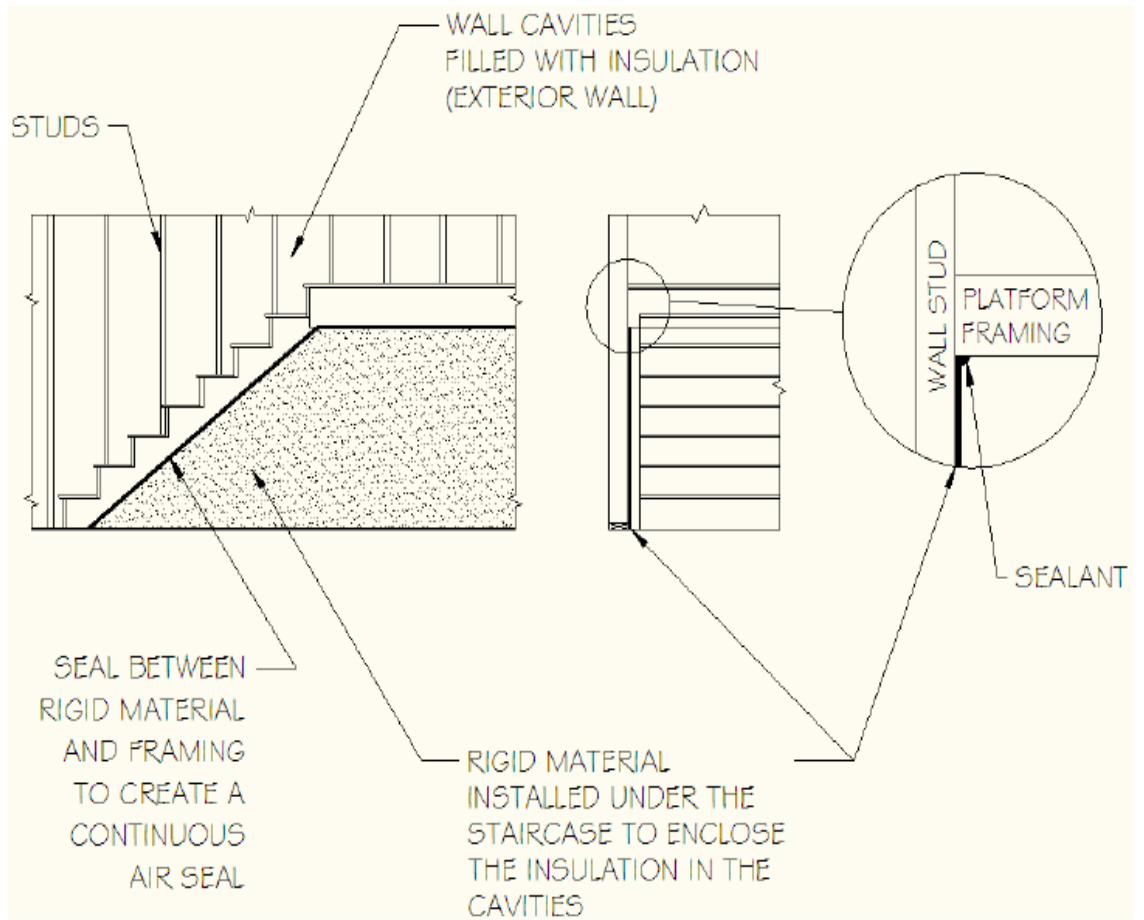

**SECTION VIEW OF INTERIOR STAIRCASE ON EXTERIOR WALL  
(OPTION 1)**

**N1102.2.12 Framed cavity walls. Insulation enclosure – 3. Stairs**

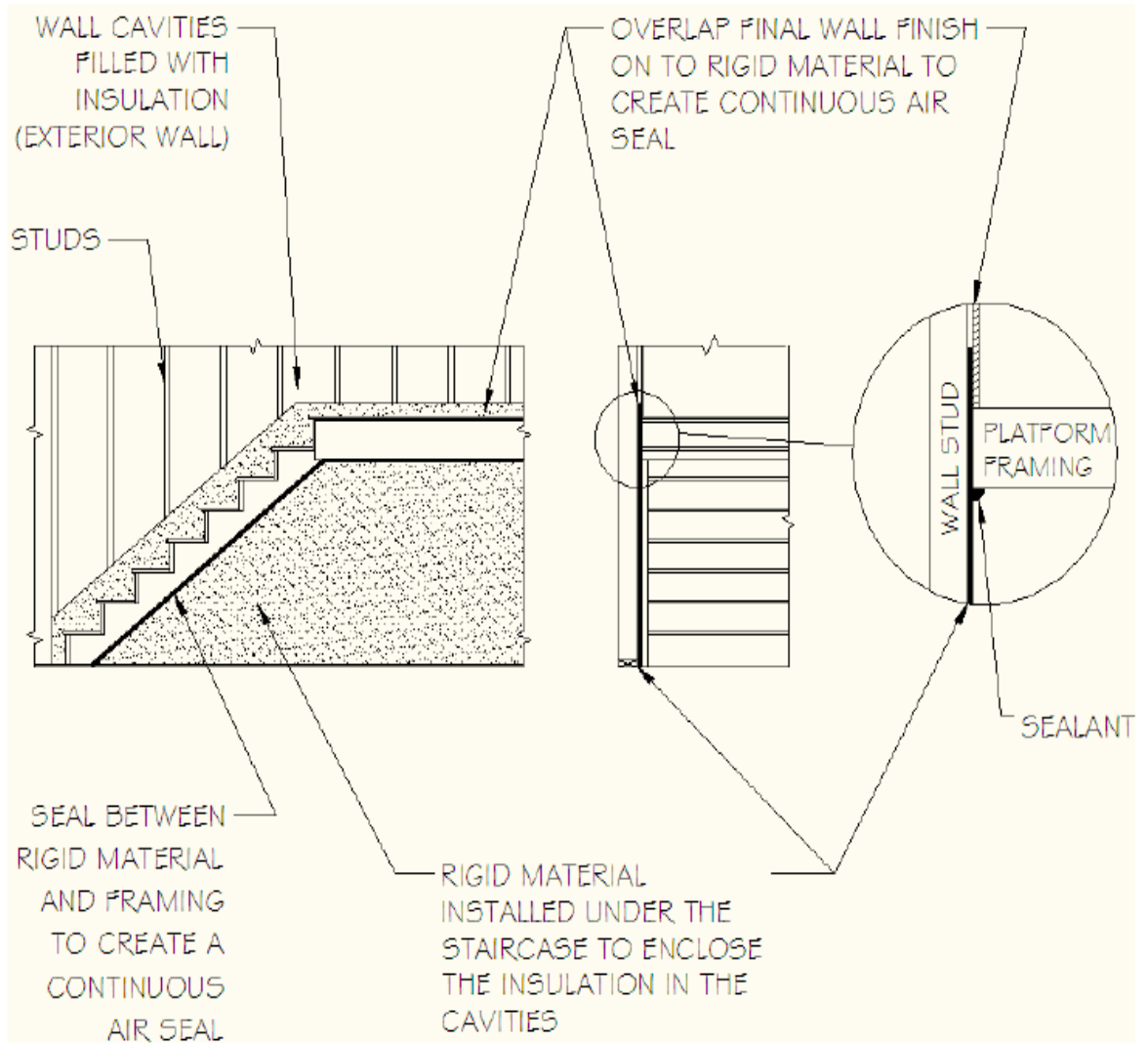

**SECTION VIEW OF INTERIOR STAIRCASE ON EXTERIOR WALL  
(OPTION 2)**

**N1102.2.12 Framed cavity wall. Insulation enclosure – 4. Direct vent gas fireplace**

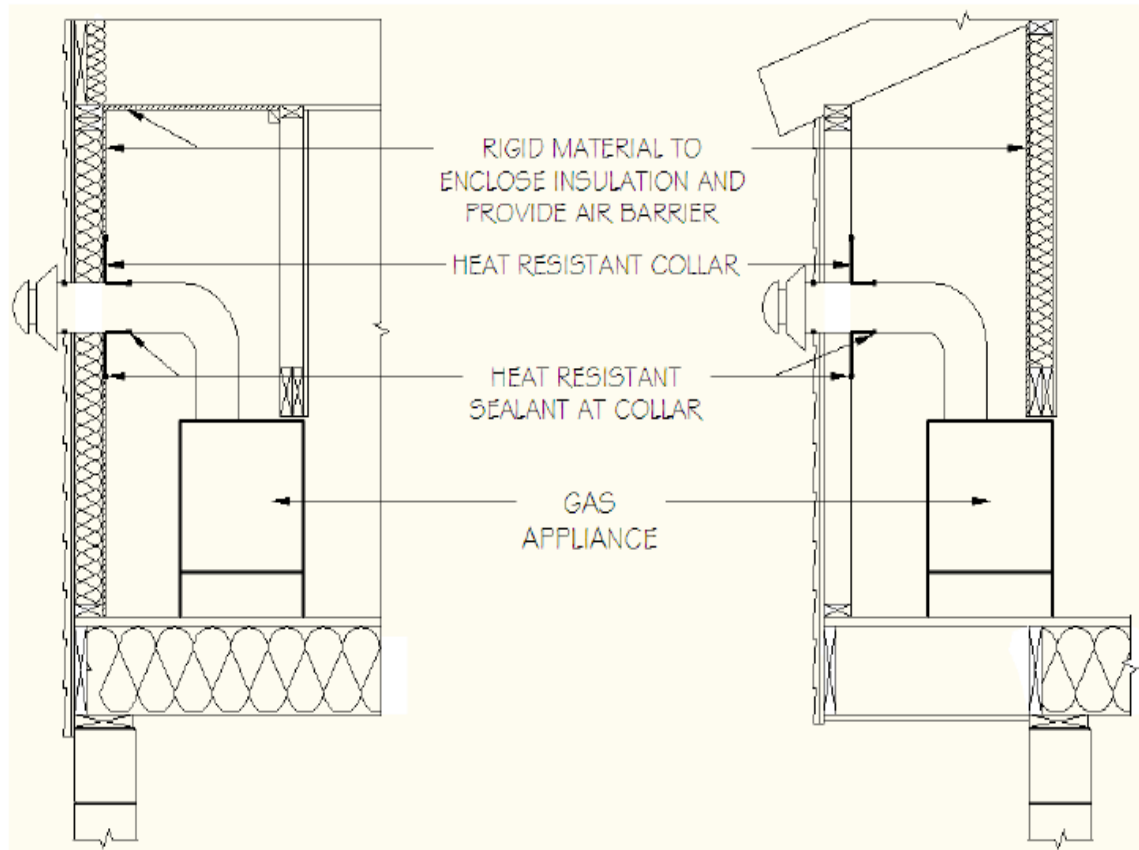

**SECTION VIEW OF DIRECT VENT GAS FIREPLACE**

**N1102.2.12 Framed cavity walls. Insulation enclosure – 5. Walls that adjoin attic spaces**

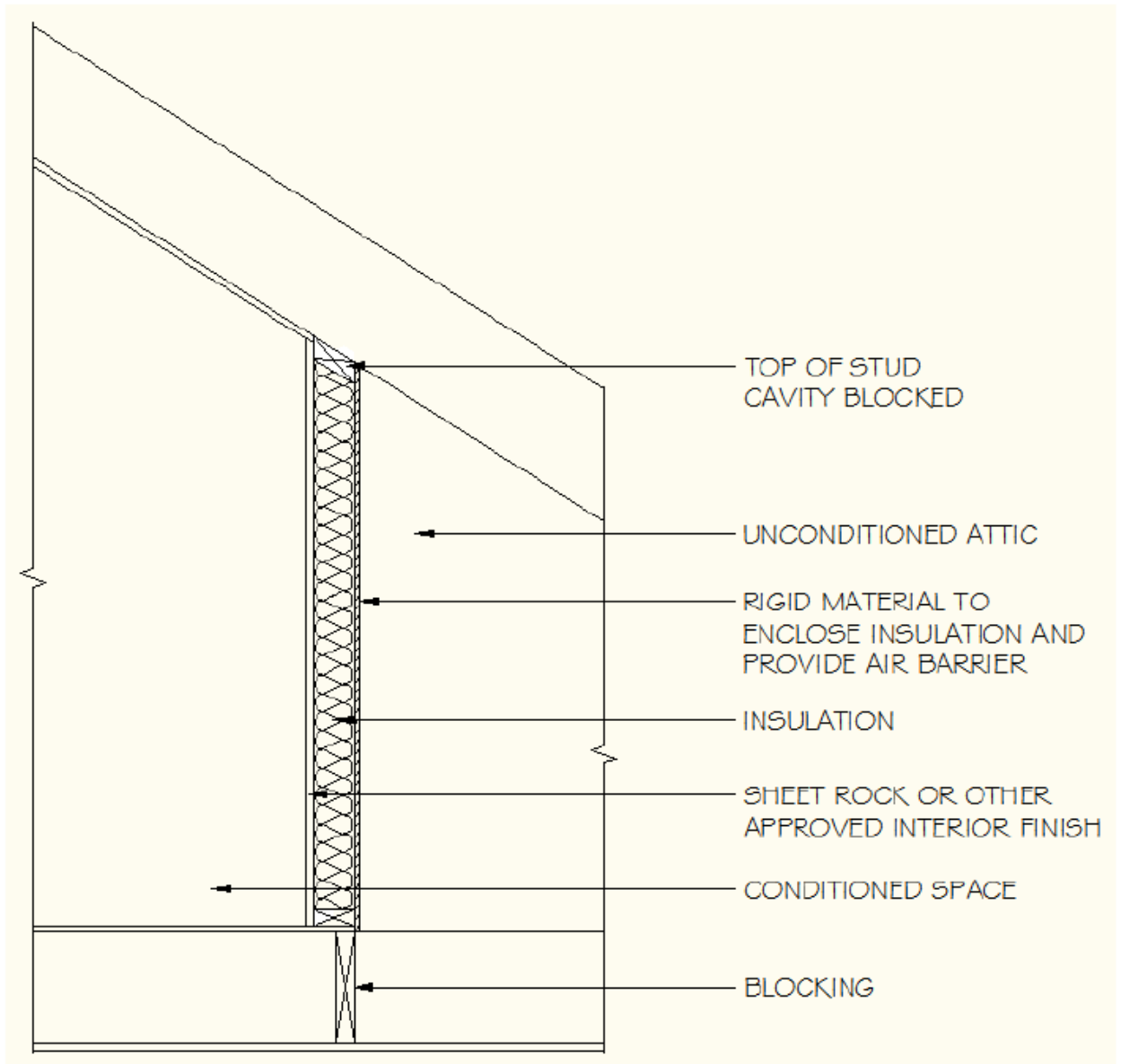

**SECTION VIEW OF WALL ADJOINING ATTIC SPACE**

**N1102.2.12 Framed cavity walls. Insulation enclosure – 5. Walls that adjoin attic spaces**

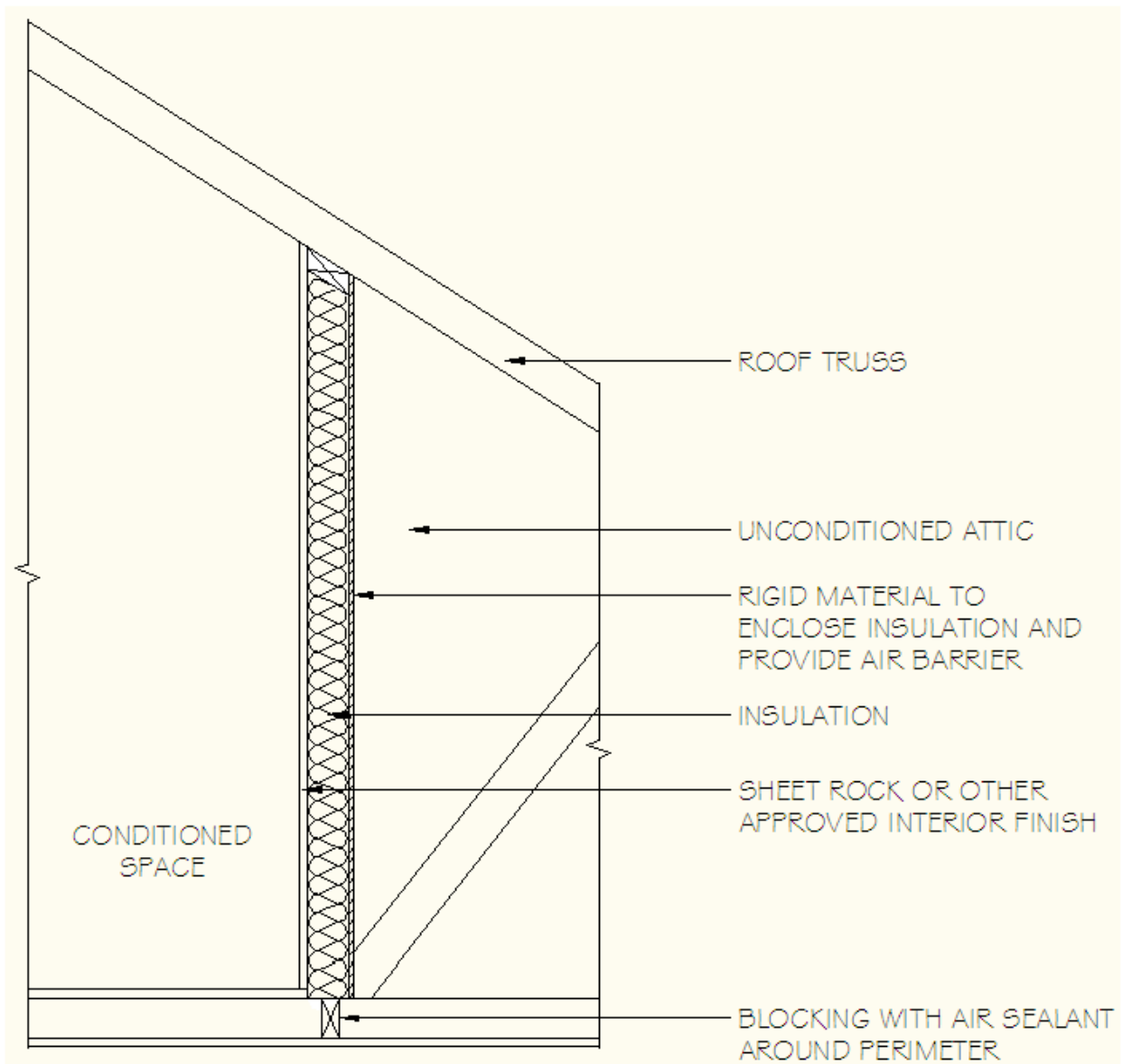

**SECTION VIEW OF WALL ADJOINING ATTIC SPACE**

## APPENDIX E-2.4

### N1102.4.1 Building thermal envelope. – 1. Block and seal floor/ceiling systems

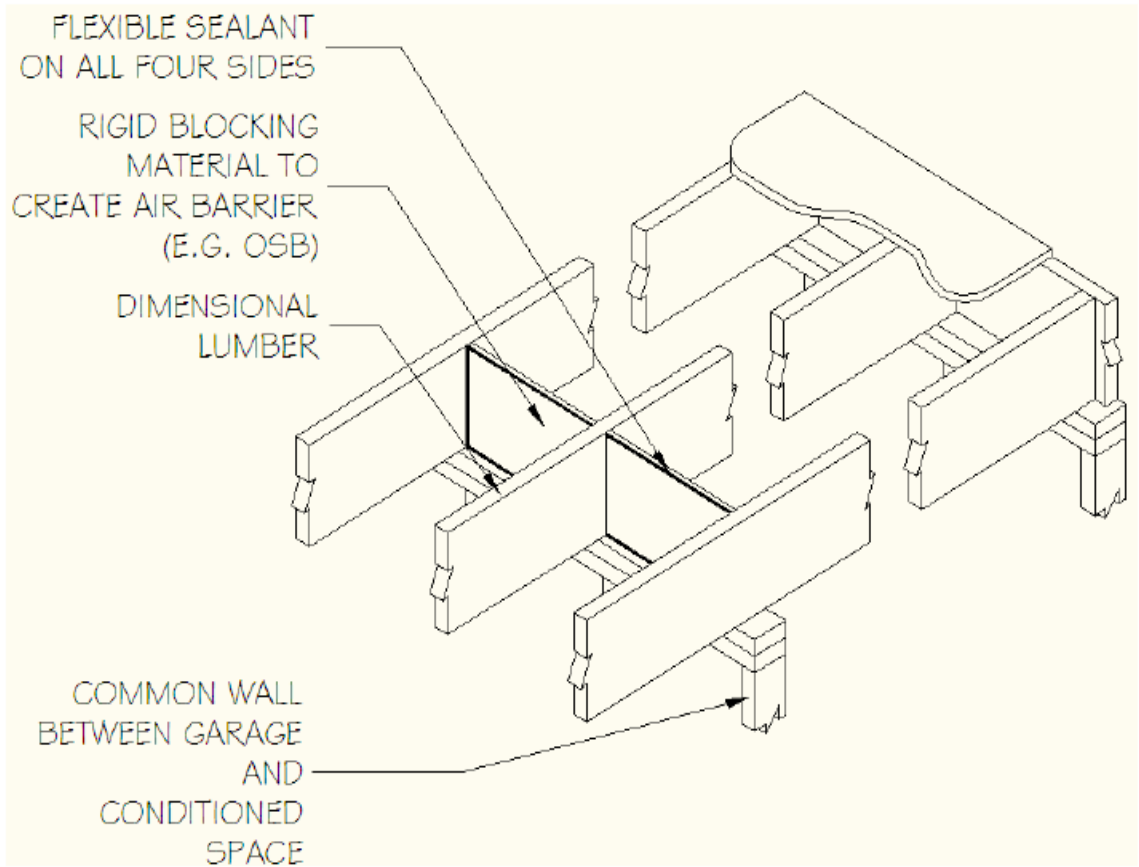

**ISOMETRIC VIEW OF DIMENSIONAL LUMBER FLOOR/CEILING SYSTEM  
ABOVE COMMON WALL BETWEEN GARAGE AND CONDITIONED SPACE  
(E.G. KNEE WALL)**

**N1102.4.1 Building thermal envelope. – 1. Block and seal floor/ceiling systems**

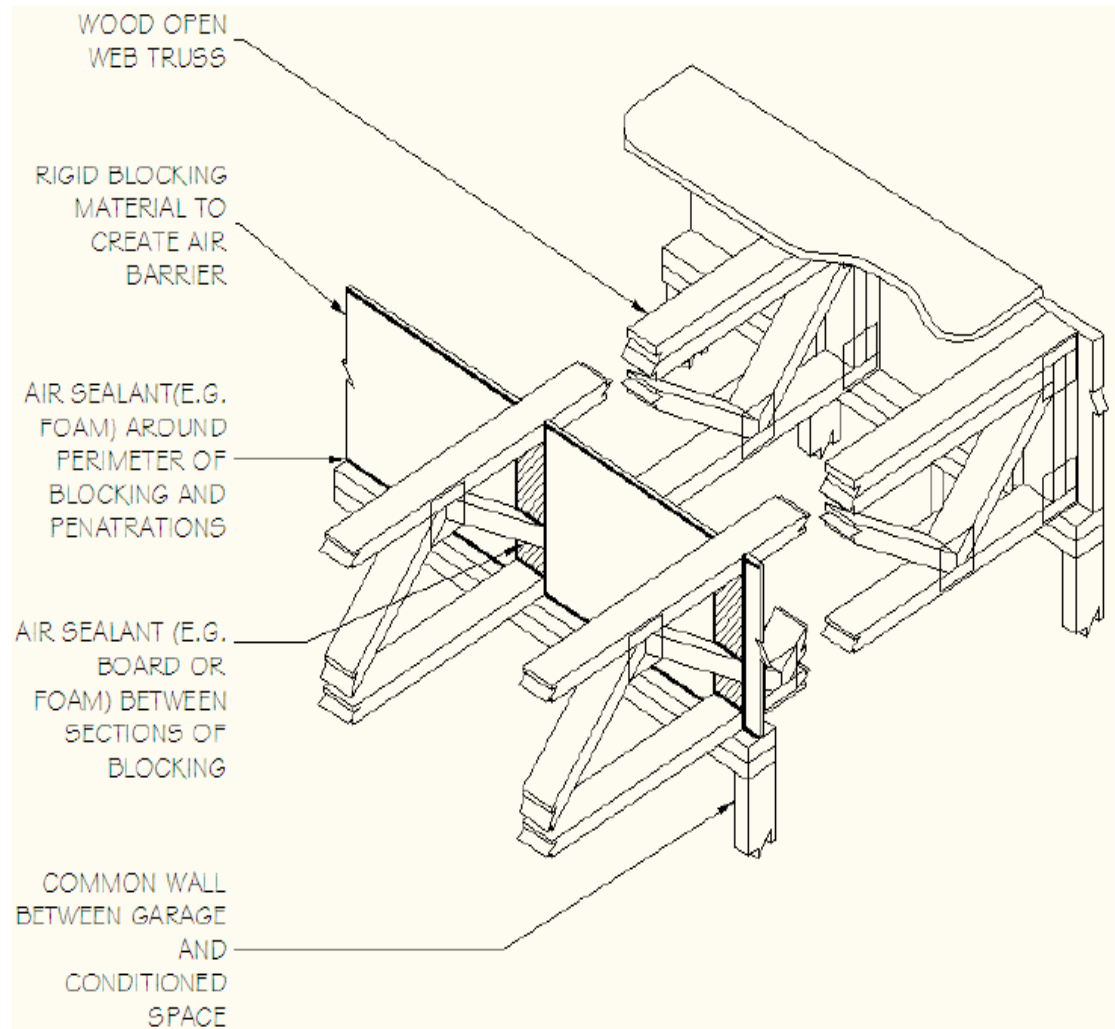

**ISOMETRIC VIEW OF WOOD TRUSS FLOOR/CEILING SYSTEM ABOVE COMMON WALL BETWEEN GARAGE AND CONDITIONED SPACE**

**N1102.4.1 Building thermal envelope. – 1. Block and seal floor/ceiling systems**

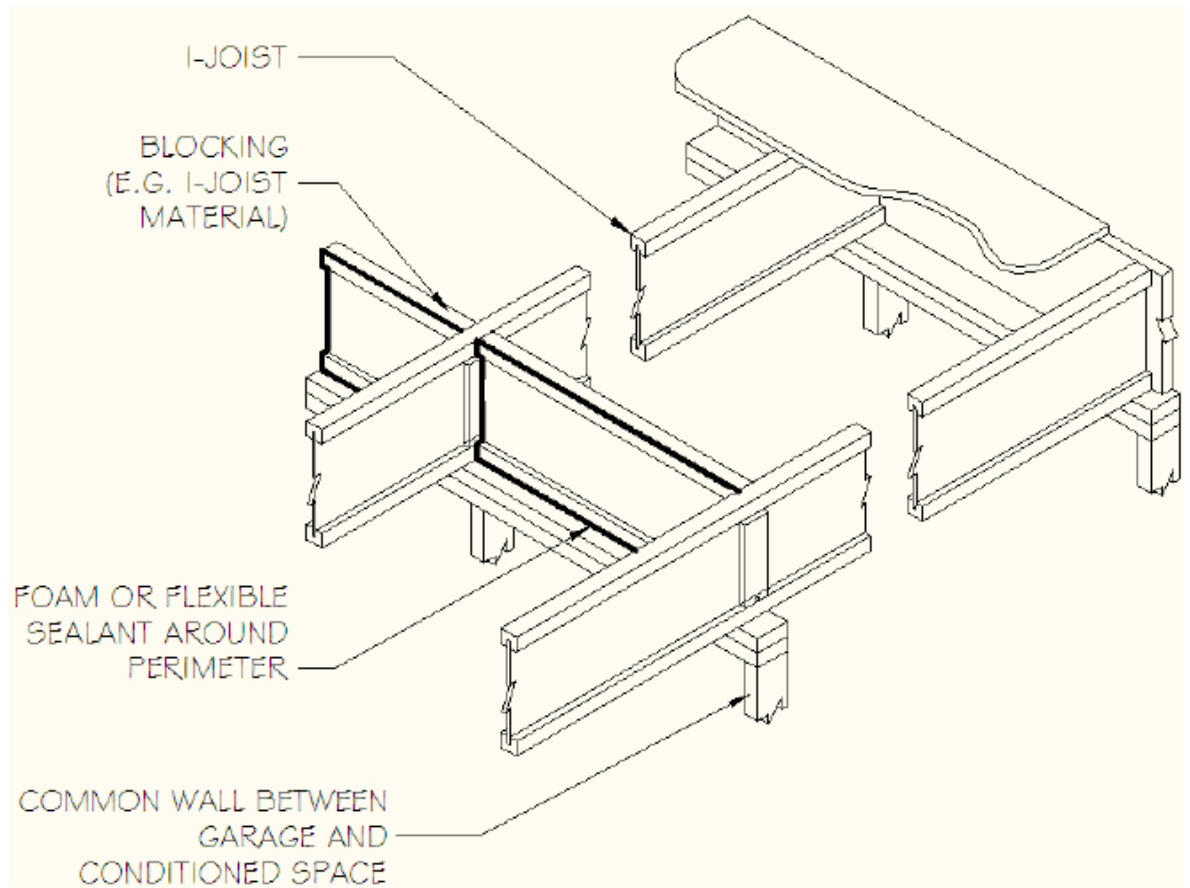

**ISOMETRIC VIEW OF I-JOIST FLOOR/CEILING SYSTEM ABOVE COMMON WALL BETWEEN GARAGE AND CONDITIONED SPACE**



**N1102.4.1 Building thermal envelope – 2. Cap and seal shafts and chases**

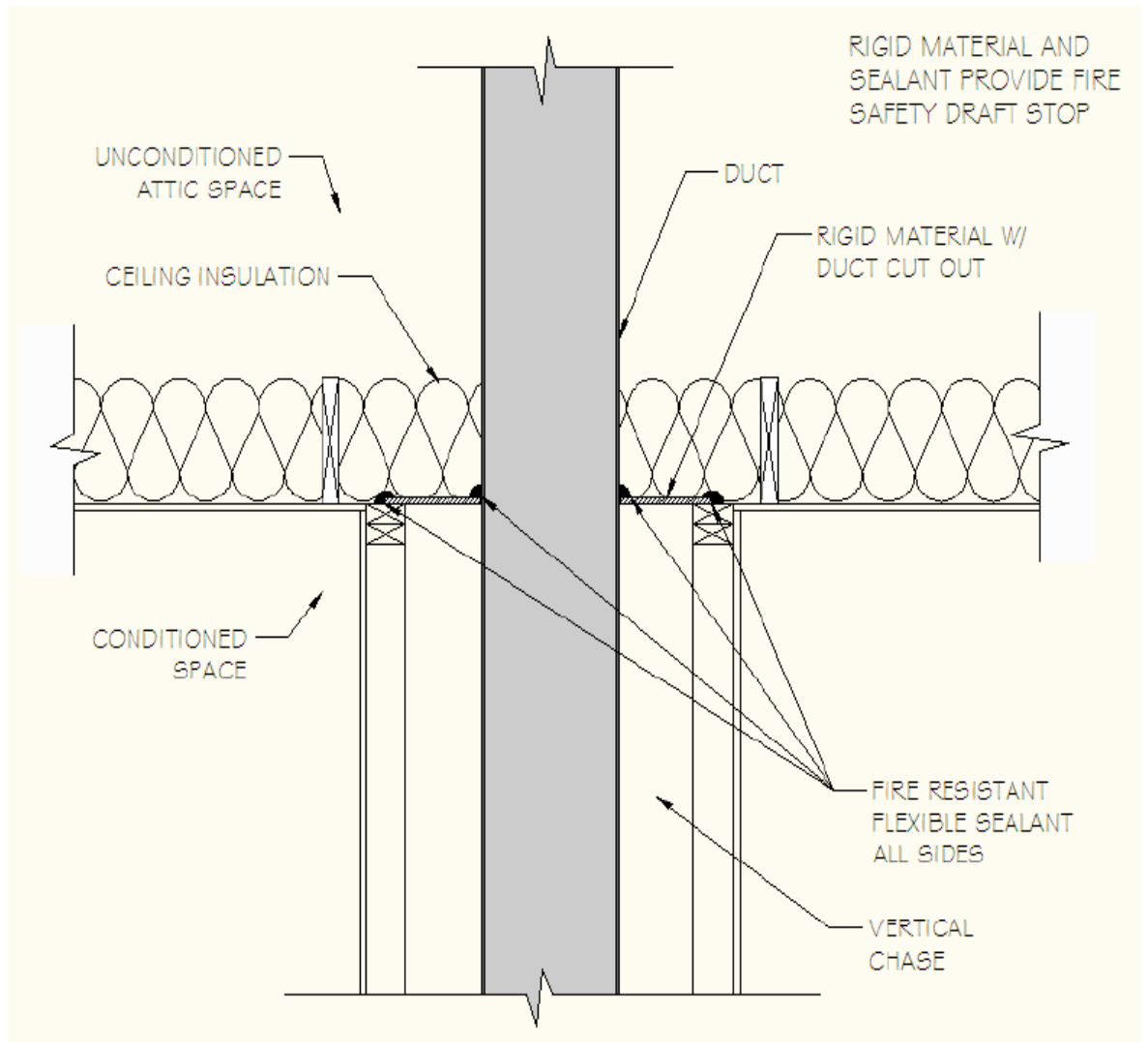

**SECTION VIEW OF DUCT PENETRATING INTO ATTIC**

**N1102.4.1 Building thermal envelope. – 3. Cap and seal soffit or dropped ceiling**

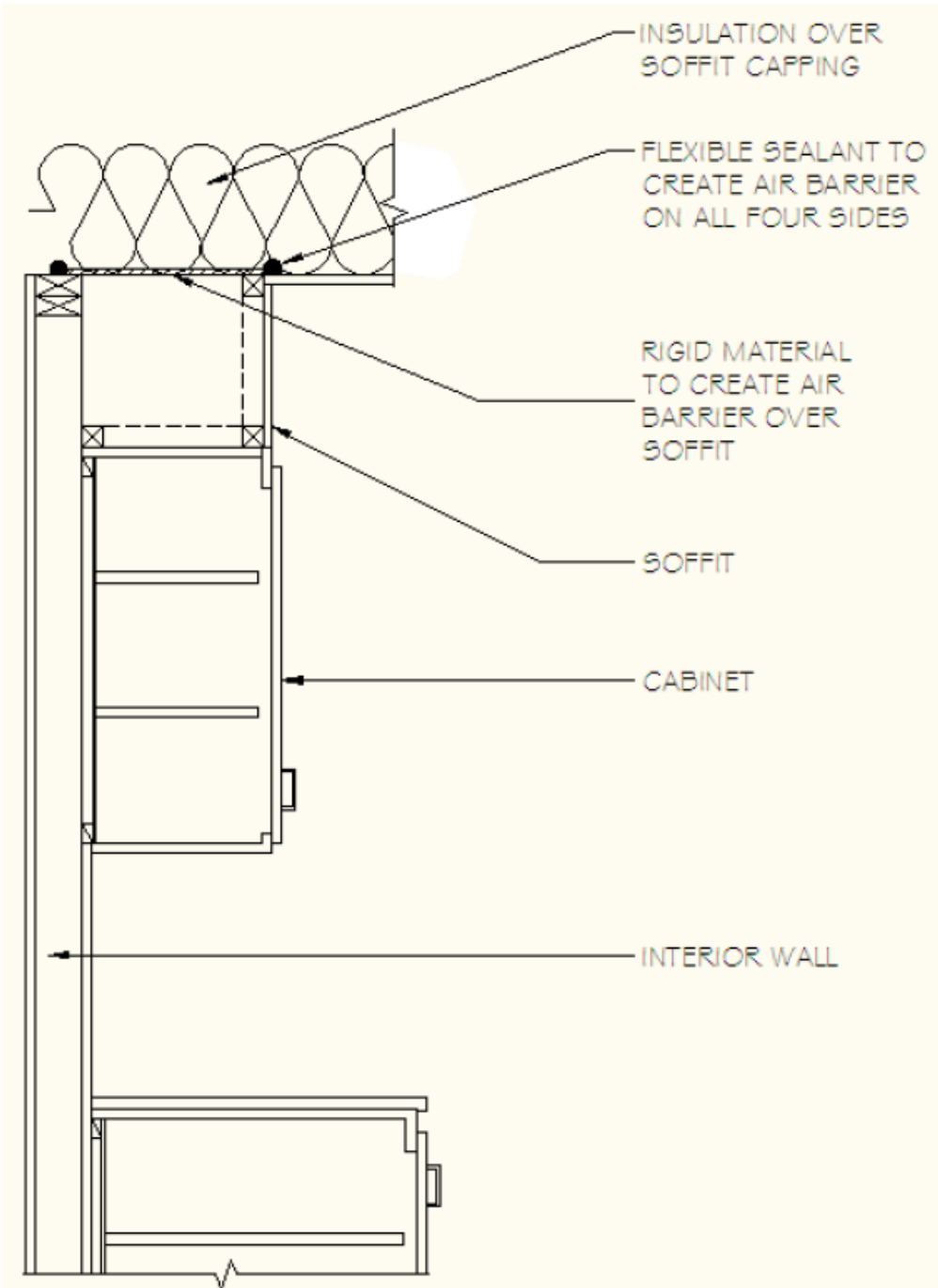

**SECTION VIEW OF SOFFIT OVER CABINET**

**N1102.4.1 Building thermal envelope. – 4. Seal HVAC boot penetration – floor**

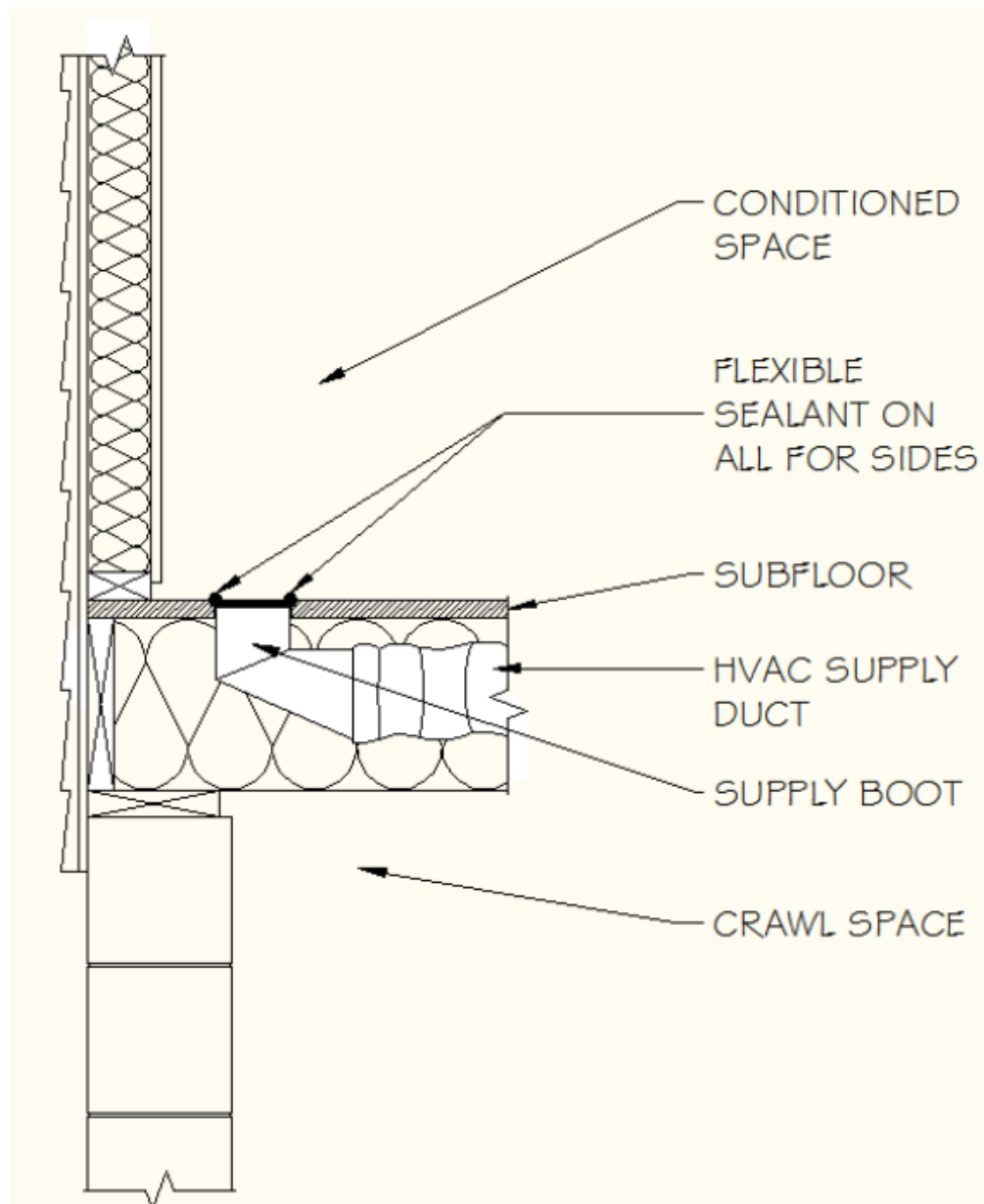

**SECTION VIEW OF FLOOR HVAC BOOT PENETRATION**

**N1102.4.1 Building thermal envelope. – 4. Seal HVAC boot penetration – ceiling**

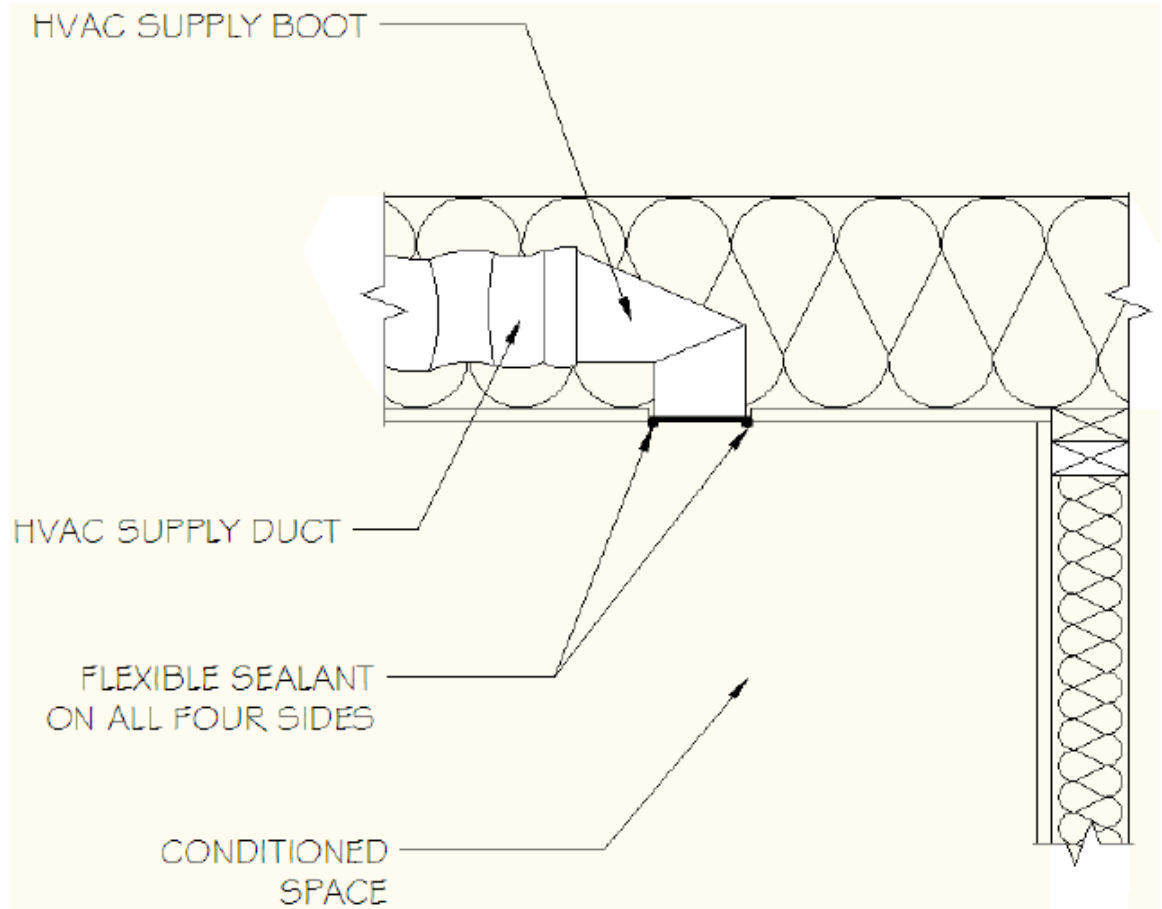

**SECTION VIEW OF CEILING HVAC BOOT PENETRATION**

## APPENDIX E-3: SAMPLE WORKSHEETS FOR RESIDENTIAL AIR AND DUCT LEAKAGE TESTING

### APPENDIX 3A

#### Air sealing: Visual inspection option (Section N1102.4.2.1)

#### Sample Worksheet

**N1102.4.2 Air sealing.** Building envelope air tightness shall be demonstrated by Section N1102.4.2.1 or N1102.4.2.2:

**N1102.4.2.1 Visual inspection option.** Building envelope tightness shall be considered acceptable when items providing insulation enclosure in N1102.2.12 and air sealing in N1102.4.1 are addressed and when the items listed in Table N1102.4.2, applicable to the method of construction, are certified by the permit holder or the general contractor via an air sealing verification checklist.

**TABLE N1102.4.2  
AIR BARRIER INSPECTION**

COMPONENT	CRITERIA
Ceiling/attic	<p>Sealants or gaskets provide a continuous air barrier system joining the top plate of framed walls with either the ceiling drywall or the top edge of wall drywall to prevent air leakage. Top plate penetrations are sealed.</p> <p>For ceiling finishes that are not air barrier systems such as tongue-and-groove planks, air barrier systems,(for example, taped house wrap), shall be used above the finish</p> <p>Note: It is acceptable that sealants or gaskets applied as part of the application of the drywall will not be observable by the code official</p>
Walls	Sill plate is gasketed or sealed to subfloor or slab.
Windows and doors	Space between window and exterior door jambs and framing is sealed.
Floors (including above-garage and cantilevered floors)	Air barrier system is installed at any exposed edge of insulation.
Penetrations	Utility penetrations through the building thermal envelope, including those for plumbing, electrical wiring, ductwork, security and fire alarm wiring, and control wiring, shall be sealed.
Garage separation	Air sealing is provided between the garage and conditioned spaces. An air barrier system shall be installed between the ceiling system above the garage and the ceiling system of interior spaces.
Recessed lighting	Recessed light fixtures are air tight, IC rated, and sealed to drywall. Exception—fixtures in conditioned space.

**Property Address:**

\_\_\_\_\_

#### **N1102.4.2.1 Visual Inspection Option**

Items providing insulation enclosure in N1102.2.12 and air sealing in N1102.4.1 are addressed and items listed in Table N1102.4.2, applicable to the method of construction, are certified as complete.

\_\_\_\_\_

Permit Holder or General Contractor

\_\_\_\_\_

Date

**APPENDIX 3B**  
**Air sealing: Testing option (Section N1102.4.2.2)**  
**Sample Worksheet**

**N1102.4.2 Air sealing.** Building envelope air tightness shall be demonstrated by Section N1102.4.2.1 or N1102.4.2.2:

**N1102.4.2.2 Testing option.** Building envelope tightness shall be considered acceptable when items providing insulation enclosure in N1102.2.12 and air sealing in N1102.4.1 are addressed and when tested air leakage is less than or equal to one of the two following performance measurements:

1. 0.24 CFM50/Square Foot of Surface Area (SFSA) or
2. Four (4) air changes per hour (ACH50)

When tested with a blower door fan assembly, at a pressure of 33.5 psf (50 Pa). A single point depressurization, not temperature corrected, test is sufficient to comply with this provision, provided that the blower door fan assembly has been certified by the manufacturer to be capable of conducting tests in accordance with ASTM E779-03. Testing shall occur after rough in and after installation of penetrations of the building envelope, including penetrations for utilities, plumbing, electrical, ventilation and combustion appliances. Testing shall be reported by the permit holder, a NC licensed general contractor, a NC licensed HVAC contractor, a NC licensed Home Inspector, a registered design professional, a *certified BPI Envelope Professional* or a *certified HERS rater*.

During testing:

1. Exterior windows and doors, fireplace and stove doors shall be closed, but not sealed;
2. Dampers shall be closed, but not sealed, including exhaust, intake, makeup air, backdraft, and flue dampers;
3. Interior doors shall be open;
4. Exterior openings for continuous ventilation systems, air intake ducted to the return side of the conditioning system, and energy or heat recovery ventilators shall be closed and sealed;
5. Heating and cooling system(s) shall be turned off; and
6. Supply and return registers shall not be sealed.

The air leakage information, including building air leakage result, tester name, date, company and contact information, shall be included on the certificate described in Section N1101.9.

**For Test Criteria 1** above, the report shall be produced in the following manner: Perform the blower door test and record the *CFM50* \_\_\_\_\_. Calculate the total square feet of surface area for the building thermal envelope, all floors, ceilings, and walls (this includes windows and doors) and record the area \_\_\_\_\_. Divide *CFM50* by the total square feet and record the result below. If the result is less than or equal to [0.24 CFM50/SFSA] the envelope tightness is acceptable; or

**For Test Criteria 2** above, the report shall be produced in the following manner: Perform a blower door test and record the *CFM50* \_\_\_\_\_. Multiply the *CFM50* by 60 minutes to create *CFHour50* and record \_\_\_\_\_. Then calculate the total conditioned volume of the home and record \_\_\_\_\_. Divide the *CFHour50* by the total volume and record the result below. If the result is less than or equal to [4 ACH50] the envelope tightness is acceptable.

**Property Address:**

\_\_\_\_\_

**N1102.4.2.2 Testing Option**

Items providing insulation enclosure in N1102.2.12 and air sealing in N1102.4.1 are addressed and tested air leakage is certified to be less than or equal to one of the following performance measurements:

- 1. 0.24 CFM50/Square Foot of Surface Area (SFSA)      Result: \_\_\_\_\_ CFM50/SFSA
- 2. Four air changes per hour (ACH50)                  Result: \_\_\_\_\_ ACH50

Fan attachment location \_\_\_\_\_ Company Name \_\_\_\_\_  
Contact Information \_\_\_\_\_

\_\_\_\_\_  
\_\_\_\_\_  
\_\_\_\_\_

Signature of Tester

Date

Permit Holder, NC Licensed General Contractor, NC Licensed HVAC Contractor,  
NC Licensed Home Inspector, Registered Design Professional,  
Certified BPI Envelope Professional, or Certified HERS Rater (**circle one**)

## APPENDIX 3C

### Duct sealing. Duct air leakage test (Section N1103.2.2)

#### Sample Worksheet

**N1103.2.2 Sealing (Mandatory Requirements).** All ducts, air handlers, filter boxes and building cavities used as ducts shall be sealed. Joints and seams shall comply with Section 603 of the *NC Mechanical Code*

Duct tightness shall be verified as follows:

Total duct leakage less than or equal to 4 CFM (12 L/min) per 100 ft<sup>2</sup> (9.29 m<sup>2</sup>) of *conditioned floor area* served by that system when tested at a pressure differential of 0.1 inches w.g. (25 Pa) across the entire system, including the manufacturer's air handler enclosure.

During testing:

1. Block, if present, the ventilation air duct connected to the conditioning system.
2. The duct air leakage testing equipment shall be attached to the largest return in the system or to the air handler.
3. The filter shall be removed and the air handler power shall be turned off.
3. Supply boots or registers and return boxes or grilles shall be taped, plugged, or otherwise sealed air tight.
4. The hose for measuring the 25 Pascals of pressure differential shall be inserted into the boot of the supply that is nominally closest to the air handler.
5. Specific instructions from the duct testing equipment manufacturer shall be followed to reach duct test pressure and measure duct air leakage.

Testing shall be performed and reported by the permit holder, a NC licensed general contractor, a NC licensed HVAC contractor, a NC licensed Home Inspector, a registered design professional, a certified BPI Envelope Professional or a certified HERS rater. A single point depressurization, not temperature corrected, test is sufficient to comply with this provision, provided that the duct testing fan assembly has been certified by the manufacturer to be capable of conducting tests in accordance with ASTM 1554-07.

The duct leakage information, including fan attachment location, building duct leakage result, tester name, date, company and contact information, shall be included on the certificate described in Section N1101.9.

For the Test Criteria, the report shall be produced in the following manner: perform the HVAC system air leakage test and record the CFM25. Calculate the total square feet of Conditioned Floor Area (CFA) served by that system. Divide the Conditioned Floor Area by 100 to provide the number of CFA100. Divide the CFM25 by the number of CFA100 and record the result. If the result is less than or equal to [4 CFM25/100 SF] the HVAC system air tightness is acceptable.

**Complete one duct leakage report for each HVAC system serving the home:**

Property Address:

\_\_\_\_\_

**HVAC System Number:** \_\_\_\_\_ Describe area of home served: \_\_\_\_\_

CFM25 Total \_\_\_\_\_ Conditioned Floor Area [s.f.] served by system \_\_\_\_\_

CFA divided by 100 = CFA100 = \_\_\_\_\_ . CFM25 Total divided by CFA100 = \_\_\_\_\_ **CFM25/100SF**

Fan attachment location \_\_\_\_\_ Company Name \_\_\_\_\_



Contact Information

\_\_\_\_\_

\_\_\_\_\_

Signature of Tester

\_\_\_\_\_

Date

Permit Holder, NC Licensed General Contractor, NC Licensed HVAC Contractor,  
NC Licensed Home Inspector, Registered Design Professional,  
Certified BPI Envelope Professional, or Certified HERS Rater **(circle one)**

<b>Appendix F Radon Control Methods</b>	Delete
<b>Appendix G</b>	<b>Add in approved amendments</b>
<b>Appendix H</b>	Delete
<b>Appendix J</b>	Delete
<b>Appendix L</b>	Delete

Replace entire section with the following:

## Appendix M Wood Decks

(Entire section is a NC amended appendix)

### Section AM101 General

**AM101.1 General.** A deck is an exposed exterior wood floor structure which may be attached to the structure or freestanding. Roofed porches (open or screened-in) may be constructed using these provisions.

**AM101.2 Deck design.** Computer deck design programs may be accepted by the Code Enforcement Official.

### Section AM102 Footers

**AM102.1 Footers.** Support post shall be supported by a minimum footing per Figure AM102 and Table AM102.1 Minimum footing depth shall be 12" below finished grade per R403.1.4. Tributary area is calculated per Figure AM102.1.

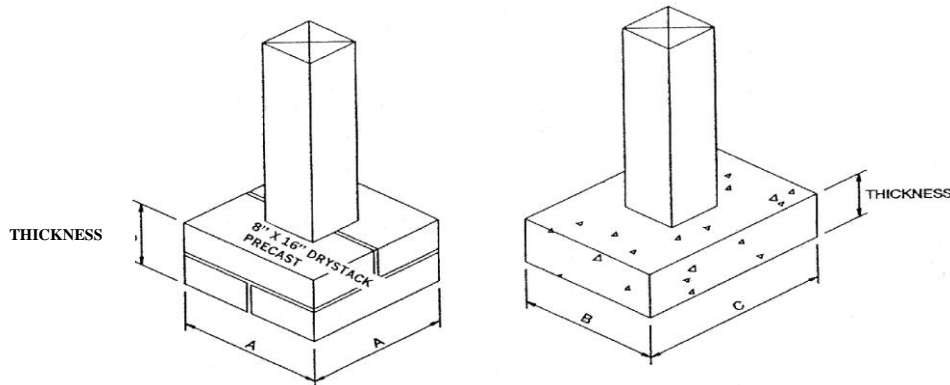

**Figure AM102**

**Table AM102.1**

Footing table <sup>a, b, c</sup>

Size (inches)		Tributary Area (Sq. Ft.)	Thickness (inches)	
A x A	B x C		Precast	Cast-in-place
8 x 16	8 x 16	36	4"	6"
12 x 12	12 x 12	40	4"	6"
16 x 16	16 x 16	70	8"	8"
----	16 x 24	100	--	8"
	24 x 24	150	--	8"

- a. Footing values are based on single floor and roof loads
- b. Support post must rest in center 1/3 of footer
- c. Top of footer shall be level for full bearing support of post

### Section AM103 Flashing

**AM103.1 Flashing.** When attached to a structure, the structure to which attached shall have a treated wood band for the length of the deck, or corrosion-resistant flashing shall be used to prevent moisture from coming in contact with the untreated framing of the structure. Aluminum flashing shall not be used in conjunction with deck construction. The deck band and the structure band shall be constructed in contact with each other except on brick veneer structures and where plywood sheathing is required and properly flashed. Siding shall not be installed between the structure and the deck band. If attached to a brick structure, neither the flashing nor a treated band for brick structure is required. In addition, the treated deck band shall be constructed in contact with the brick veneer. Flashing shall be installed per Figure AM103.

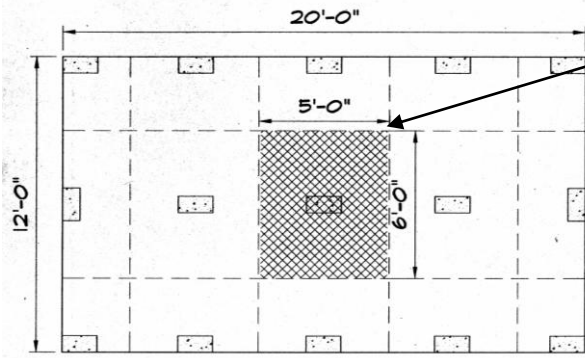

Tributary area of shaded section on free standing deck shown is 5'x6'=30 sq. ft. Code will require a minimum footer of 8"x 16" per Table AM102.1

**Figure AM102.1**

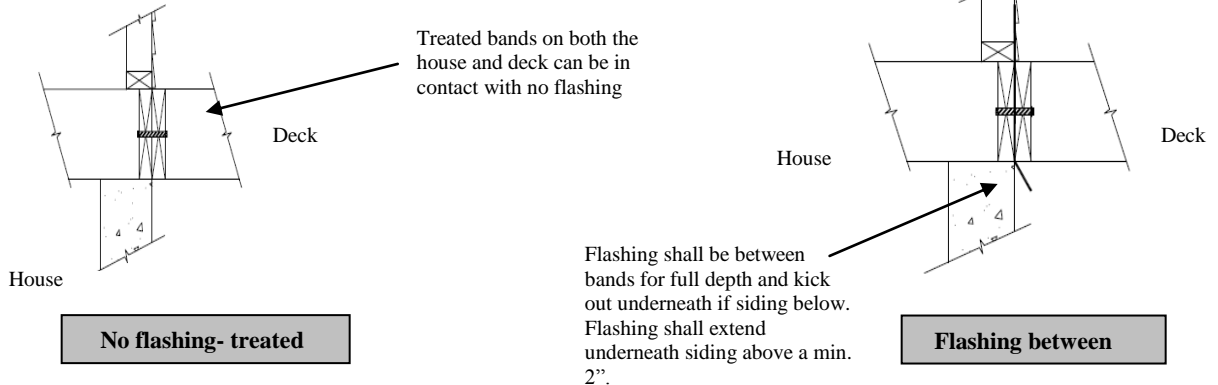

**Figure AM103**

**Section AM104  
Deck attachment**

**AM104.1 Deck Attachment.** When a deck is supported at the structure by attaching the deck to the structure, the following attachment schedules shall apply for attaching the deck band to the structure.

**AM104.1.1 All Structures Except Brick veneer Structures:**

Fasteners	8' Max Joist Span <sup>a</sup>	16' Max Joist Span <sup>a</sup>
5/8" Hot Dipped Galv. Bolts with nut and washer <sup>b</sup>	1 @ 3'-6" o.c.	1 @ 1'-8" o.c.
<b>and</b>	<b>and</b>	<b>and</b>
12d Common Hot Dipped Galv. Nails <sup>c</sup>	2 @ 8" o.c.	3 @ 6" o.c.

- a. Attachment interpolation between 8' & 16' joists span are allowed
- b. Minimum edge distance for bolts is 2 1/2 inches
- c. Nails must penetrate the supporting structure band a minimum of 1 1/2 inches

**AM104.1.2 Brick Veneer Structures**

Fasteners	8' Max Joist Span <sup>a</sup>	16' Max joist Span <sup>a</sup>
5/8" Hot Dipped Galv. Bolts with Nut and Washer <sup>b</sup>	1 @ 2'-4" o.c.	1 @ 1'-4" o.c.

- a. Attachment interpolation between 8' & 16' is allowed
- b. Minimum edge distance for bolts is 2 1/2 inches

**AM104.1.3 Masonry Ledge Support**

If the deck band is supported by a minimum of 1/2 inch masonry ledge along the foundation wall, 5/8 inch hot dipped galvanized bolts with washers spaced at 48 inches o.c. may be used for support.

**AM104.1.4 Other means of support**

Joist hangers or other means of attachment may be connected to house band and shall be properly flashed

## Section AM105

**AM105.1 Girder Support & Span.** Girders shall bear directly on support post with post attached at top to prevent lateral displacement or be connected to the side of posts with two 5/8 inch hot dipped galvanized bolts with nut and washer. Girder spans are per Table R502.5 (1&2). Girder support may be installed per Figure AM105 for top mount; Figure AM105.1 for side mount and Figure AM105.2 for split girder detail. Girders may also be cantilevered off ends of support post no more than 1 joist spacing or 16" whichever is greater per Figure AM105.3.

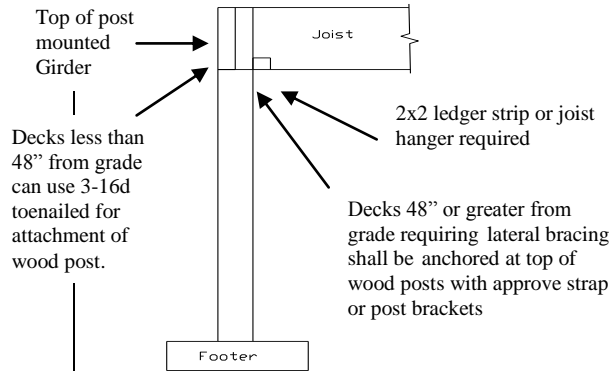

**Top mount/flush**

**Figure AM105**

## Section AM106

**M106.1 Joist Spans & Cantilevers.** Joists spans shall be based upon Table R502.3.1(2) with 40 lbs per sq. ft. live load and 10 lbs per sq. ft. dead load. Floor joists for exterior decks may be cantilevered per Table R502.3.3 (1).

Spacing	2x6	2x8	2x10	2x12
12"	10-9	14-2	18-0	21-9
16"	9-9	12-10	16-1	18-10
19.2"	9-2	12-1	14-8	17-2
24"	8-6	11-0	13-1	15-5

Partial reprint of Table R502.3.1(2), #2 SYP only joist spans

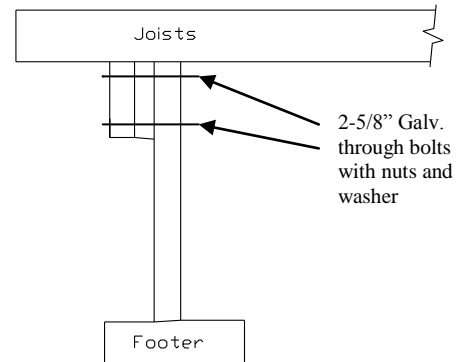

**Side mount dropped girder**

**Figure AM105.1**

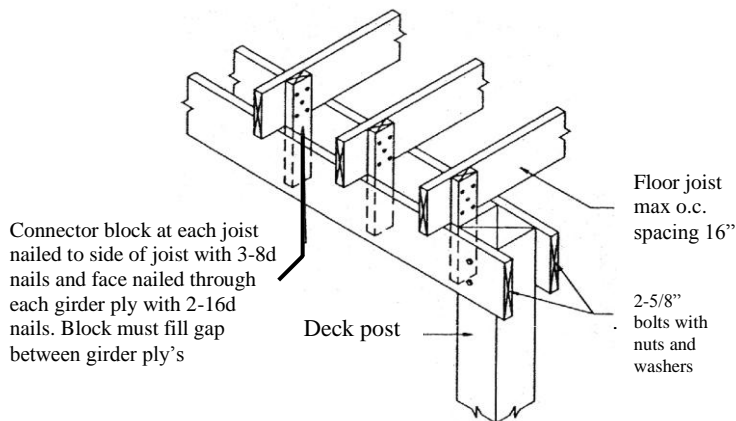

**Split girder detail**

**Figure AM105.2**

Split girder limited to floor loads only and cantilever girder ends allowed per AM105.3

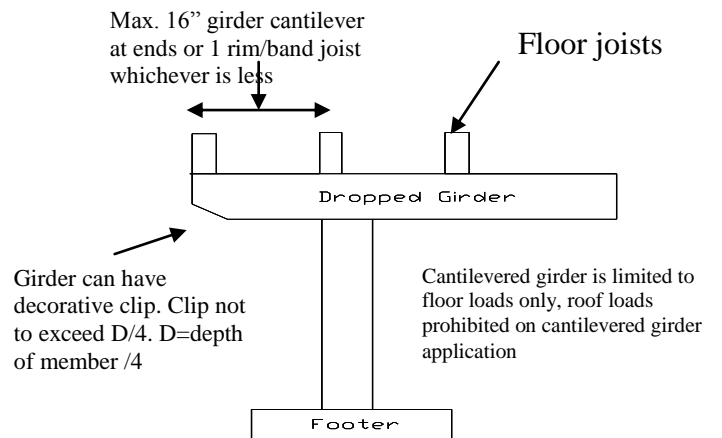

**Cantilevered dropped girder detail**

**Figure AM105.3**

## Section AM107

**AM107.1 Floor Decking.** Floor decking shall be No. 2 grade treated Southern Pine or equivalent. The minimum floor decking thickness shall be as follows:

Joist Spacing	Decking (nominal)
12" o.c.	1" S4S
16" o.c.	1" T&G
19.2 o.c.	1-1/4" S4S
24"-36" o.c.	2" S4S

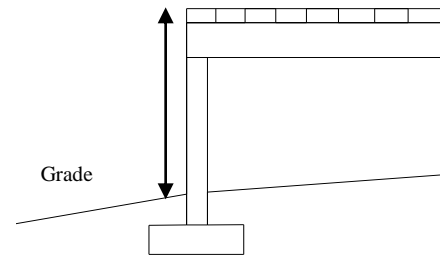

Less than 4' (decking to grade) and attached to structure no bracing required

**Figure AM109**

## Section AM108

**AM108.1 Post height.** Maximum height of Deck support posts as follows:

Post size <sup>a</sup>	Max. Post Height <sup>b,c</sup>
4x4	8'-0"
6x6	20'-0"

- a. This table is based on No. 2 Southern Pine posts.  
 b. From top of footing to bottom of girder  
 c. Decks with post heights exceeding these requirements shall be designed by a registered design professional

Freestanding decks requiring bracing shall be installed in both directions off each post

Decks attached to structure require diagonal bracing only at outside girder line parallel with structure

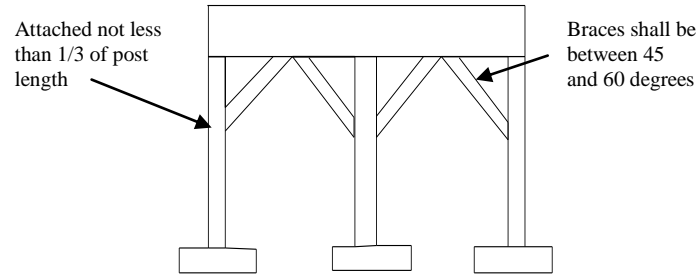

**Figure AM109.1**

## Section AM109

**AM109.1 Deck bracing.** Decks shall be braced to provide lateral stability. The following are acceptable means to provide lateral stability.

**AM109.1.1.** When the deck floor height is less than 4'-0" above finished grade per Figure AM109 and the deck is attached to the structure in accordance with Section AM104, lateral bracing is not required.

**AM109.1.2.** 4x4 wood knee braces may be provided on each column in both directions. The knee braces shall attach to each post at a point not less than 1/3 of the post length from the top of the post, and the braces shall be angled between 45 degrees and 60 degrees from the horizontal. Knee braces shall be bolted to the post and the girder/double band with one 5/8 inch hot dipped galvanized bolt with nut and washer at both ends of the brace per Figure AM109.1

**AM109.1.3.** For freestanding decks without knee braces or diagonal bracing, lateral stability may be provided by embedding the post in accordance with Figure AM109.2 and the following:

Post size	Max. Tributary Area	Max. Post Height	Embedment Depth	Concrete Diameter
4x4	48 SF	4'-0"	2'-6"	1'-0"
6x6	120 SF	6'-0"	3'-6"	1'-8"

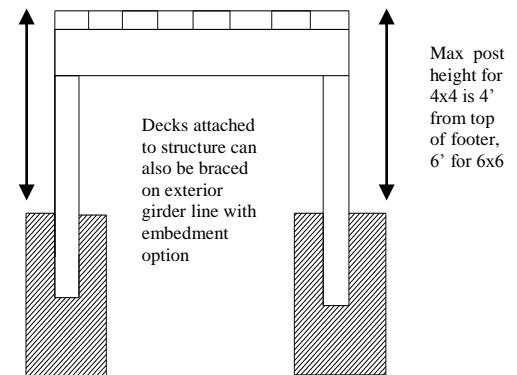

**Figure AM109.2**

**AM109.1.4** 2x6 diagonal vertical cross bracing may be provided in two perpendicular directions for freestanding decks or parallel to the structure at the exterior column line for attached decks. The 2x6's shall be attached to the posts with one 5/8 inch hot dipped galvanized bolt with nut and washer at each end of each bracing member per Figure AM109.3.

If span between post is greater than 7' center blocking and 1-5/8" bolt with nut and washer required

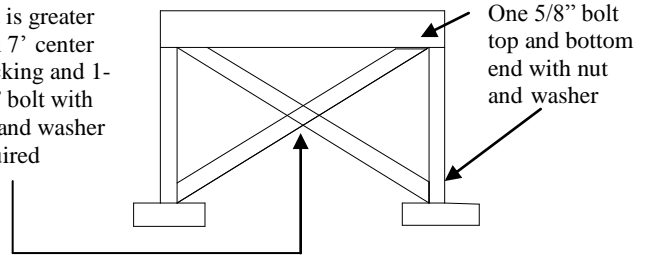

**Figure AM109.3**

**AM109.1.5** For embedment of piles in Coastal Regions, see Chapter 45.

**Section AM110**

**AM110.1 Stairs** shall be constructed per Figure AM110. Stringer spans shall be no greater than 7' span between supports. Spacing between stringers shall be based upon decking material used per AM107.1. Each Stringer shall have minimum 3 1/2" between step cut and back of stringer. If used, suspended headers shall be attached with 3/8" Galv bolts with nuts and washers to securely support stringers at the top.

Max. spacing between stringers 36".

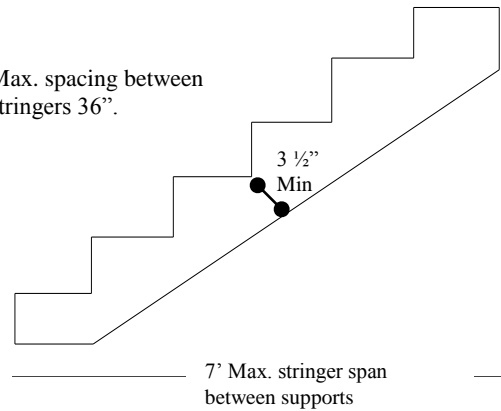

7' Max. stringer span between supports

**Figure AM110**

**Section AM111**

**AM111.1 Handrails, Guards and General.** Deck handrails, guards and general construction shall be per Figure AM111.

**Guards** at a Minimum 36" required per R312.1 with 30" drop and opening limits per R312.2 & R312.3 (4" on vertical pickets, 6" on horizontal and ornamental guard rails), top rail and post to support 200lbs with infill to meet 50lbs per Table R301.5 and footnotes.

**Attachment** to structure based upon all cladding types but brick veneer per AM104.1.1, Brick veneer per AM104.1.2, Masonry ledge per AM104.1.3 or other per AM104.1.4.

**Rail posts** cannot exceed 8' o.c. spacing and shall be attached with 2-3/8" Galv bolts with nut & washer to outer bands.

**Decking** per AM107 for #2 SYP and attached with 2-8d galv nails at each joist or approved screws. Other materials per mfg installation based upon joists o.c. spacing. Alternate material attached per mfg installation instructions.

**Stair handrail/Guard.** Height between 34"-38" per R311.7.1 & R312.2. Openings on side of stairs requiring guards shall not allow a sphere 4 3/8" to pass per R312.3 exception #2.

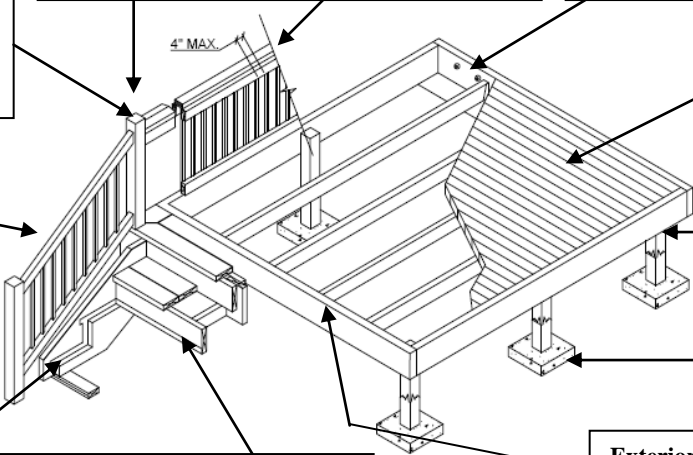

**Deck post** per AM108

**Footers** per Table AM102.1. Minimum base of footers 12" below grade.

**Stairs treads and risers** per R311.7.4.1 (8 1/2" Max riser) & R311.7.4.2 (9" minimum tread depth). Stairways min 36" width per R311.5.1 (rail projections allowed).

**Riser openings.** Stairs with a 30" or more vertical rise must have solid risers or opening restricted to prevent a 4" sphere from passing per R311.7.4.3.

**Exterior Girder Clear Spans**

Deck Width	Nominal Lumber Size			
	2x6	2x8	2x10	2x12
20' (2ply)	3-11	5-0	6-1	7-1
20' (3ply)	----	6-3	7-7	8-10
20' (4ply)	----	----	8-9	10-2

**Lateral Bracing** per AM 109. AM109.1.1 height required; AM109.1.2 knee bracing; AM109.1.3 freestanding embedment; AM109.1.4 diagonal bracing; AM109.1.5 Coastal embedment.

**Floor joist cantilevers** allowed per Table R502.3.3 (1)

\*Partial reproduction of Table R502.5(1) at 30 ground snow load and roof ceiling and 1 clear span floor. Deck width is 20' or less measured in the direction of joists span. Splices in plys must break over bearing supports.

**Figure AM111**

**WALKWAYS OVER DUNES OR BERMS IN OCEAN HAZARD AREAS**

**Title- "Figure AM112"**

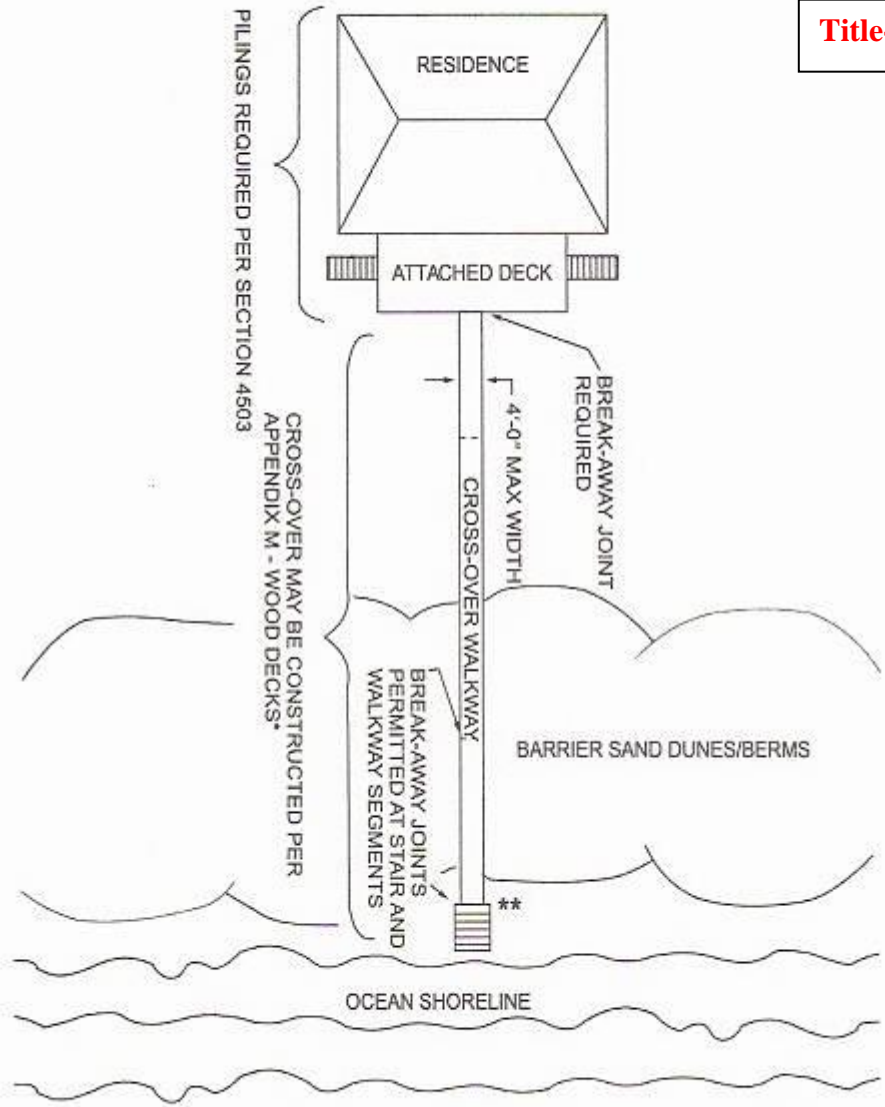

**Change reference to Chapter 45 and 46.**

For SI: 1 inch = 25.4, 1 foot = 304.8 mm.

\* Posts for walkways over dunes or berms shall be embedded a minimum depth of 4'-0" and post heights shall be limited to 5'-0" above grade for 4 x 4 and 10'-0" above grade for 6 x 6. Walkways or portions of walkways over 4'-0" in width, shall comply with the requirements of Chapters 44 and 45. Maximum walkway surface height is 30" above grade without guard rails.

\*\*Walkway stair runs can be greater than 12" without a landing.



Keep NC 2009 but change the following:

### APPENDIX N BASIC LOAD ESTIMATING

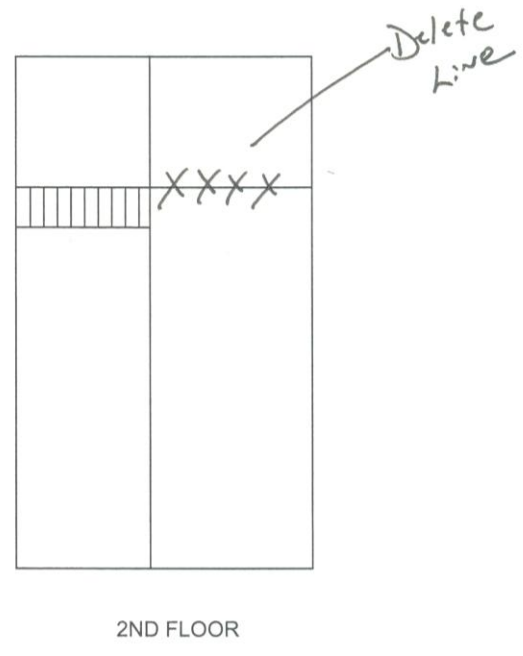
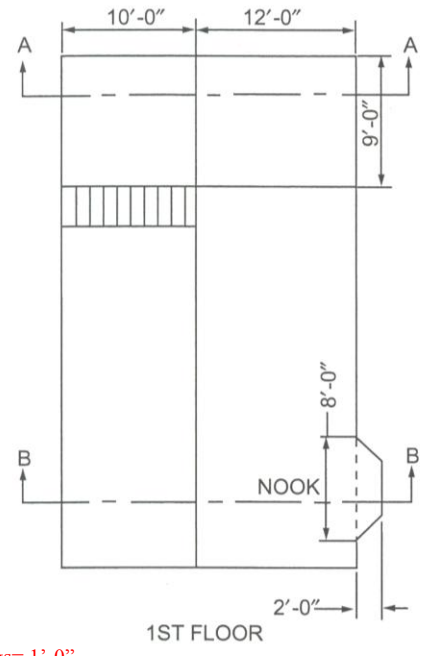

PLAN VIEW

Overhangs = 1'-0"

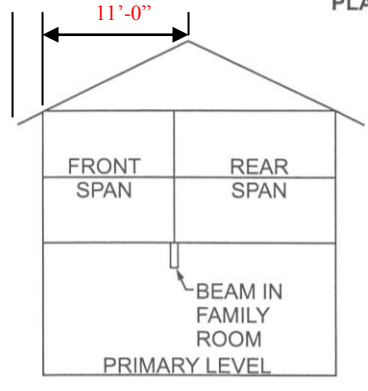

SECTION A-A

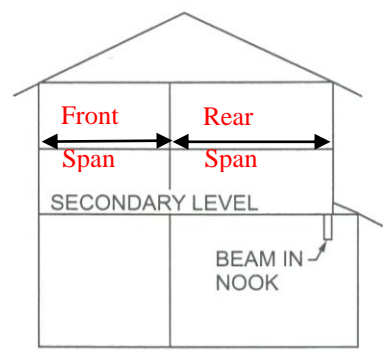

SECTION B-B

For SI: 1 inch = 25.4, 1 foot = 304.8 mm, 1 square foot = 0.0929 m<sup>2</sup>.

ASSUMPTIONS:

- Loads
- Secondary floor level is 30# L.L. + 10# D.L. = 40#/sq. ft.
- Attic level is 20# live load + 10# dead load = 30#/sq. ft.
- Nook ceiling is 10# dead load = 10#/sq. ft.
- Wall load
- Studs @ 16", 1/2" gypsum = 8#/sq. ft.
- Roof load
- 20# live load + 10# dead load = 30#/sq ft

Add to assumptions: (sleeping area live load; roof or stick frame rafters with no interior bearing)

Add: (No attic storage)

## EXAMPLE OF LOAD ESTIMATING LOAD ON BEAM IN FAMILY ROOM

Loads in Section A - A as follows:

**Total Loads**  
(in pounds/linear foot)

$$\begin{aligned} \text{2nd floor load} &= \frac{(\text{front joist span} + \text{rear joist span})}{2} \times \text{2nd floor (dead load + live load)} = \text{LOAD/linear ft} \\ &= \frac{(10 + 12)}{2} \times (10 + 30) = \frac{(22)}{2} \times (40) = 11 \times 40 = \mathbf{440} \text{ pounds/linear ft} \end{aligned}$$

Interior wall load = Wall Weight per Square foot x Wall Height = LOAD/linear foot

$$\begin{aligned} &= 8 \text{ pounds/sq. ft.} \times 8\text{ft.} = \mathbf{64} \text{ pounds/linear ft} \\ &(\text{Wall weight can vary. Verify actual weight of materials used}) \end{aligned}$$

$$\begin{aligned} \text{Attic load} &= \frac{(\text{front joist span} + \text{rear joist span})}{2} \times \text{attic (dead load + live load)} = \text{LOAD/linear ft} \\ &= \frac{(10 + 12)}{2} \times (10 + 20) = \frac{(22)}{2} \times (30) = 11 \times 30 = \mathbf{330} \text{ pounds/linear ft} \end{aligned}$$

Roof load: No roof load is transmitted to the beam in the family room. Roof Load = **0**

Total Load on Beam in Family Room = **834** pounds/1ft.

Beam span in family room is 9 feet and total estimated load is 834#/linear foot:

By using Table N-1, the required beam is 4 @ 2 x 12 SYP or SPF

OR

By using Table N-2, the required minimum flitch beam is 2@2 x 8 with 1/2"x7" steel plate bolted with 1/2" bolts spaced at 2' o.c.

## EXAMPLE OF LOAD ESTIMATING LOAD ON BEAM IN NOOK AREA

Loads in Section B - B as follows:

**Total Loads**  
(in pounds/linear foot)

$$\begin{aligned} \text{2nd floor load} &= \frac{(\text{front joist span} + \text{rear joist span})}{2} \times \text{2nd floor (dead load + live load)} = \text{LOAD/linear ft} \\ &= \frac{(0 + 12)}{2} \times (10 + 30) = \frac{(12)}{2} \times (40) = 6 \times 40 = \mathbf{240} \text{ pounds/linear ft} \end{aligned}$$

Exterior wall load = Wall Weight per Square foot x Wall Height = LOAD/linear foot

$$\begin{aligned} &= 8 \text{ pounds/sq. ft.} \times 8\text{ft.} = \mathbf{64} \text{ pounds/linear ft} \\ &(\text{Wall weight can vary. Verify actual weight of materials used}) \end{aligned}$$

$$\text{Attic load} = \frac{(\text{front joist span} + \text{rear joist span})}{2} \times \text{attic (dead load + live load)} = \text{LOAD/linear ft}$$

$$= \frac{(0 + 12)}{2} \times (10 + 20) = \frac{(12)}{2} \times (30) = 6 \times 30 = \mathbf{180 \text{ pounds/linear ft}}$$

$$\text{Roof load} = \frac{(\text{front rafter span} + \text{rear rafter span})}{2} + \text{overhang} \times \text{roof (dead load + live load)} = \text{LOAD/linear ft}$$

$$= \left( \frac{(11+11)}{2} + 1 \right) \times (10 + 20) = \left( \frac{(22)}{2} + 1 \right) \times (30) = 12 \times 30 = \mathbf{360 \text{ pounds/linear ft}}$$

$$\text{Nook Ceiling load} = \frac{(\text{joist span} + \text{joist span})}{2} \times \text{ceiling (dead load + live load)} = \text{LOAD/linear ft}$$

$$= \frac{(0+2)}{2} \times (10 + 0) = \frac{(2)}{2} \times (10) = 1 \times 10 = \mathbf{10 \text{ pounds/linear ft}}$$

$$\text{Nook Roof load} = \frac{(\text{rafter span} + \text{rafter span})}{2} \times \text{roof (dead load + live load)} = \text{LOAD/linear ft}$$

$$= \frac{(0+2)}{2} \times (10 + 20) = \frac{(2)}{2} \times (30) = 1 \times 30 = \mathbf{30 \text{ pounds/linear ft}}$$

Total Load on Beam in Nook = **884 pounds/1ft.**

Beam span in nook is 8 feet and total estimated load is 884#/linear foot:

By using Table N-1, the required beam is 3 @ 2 x 12 Southern pine or 4 @ 2 x 12 Spruce-pine-fir

OR

By using Table N-2, the required minimum flitch beam is 2@2 x 8 with 3/8"x7" steel plate bolted with 1/2" bolts spaced at 2' o.c.

## Appendix O

Same as NC 2009 except O-3 Figure needs horizontal insulation under grade removed:

