

**Part II--Definitions**

---

**CHAPTER 2  
DEFINITIONS**

**SECTION R202  
DEFINITIONS**

*Note: Following are definitions that need to be synchronized with the energy code. First are a set of simple additions that are now referenced in Chapter 11. The second list **contains** modifications to existing definitions.*

***Additional definitions:***

**ACH50.** Air Changes per Hour of measured air flow in relation to the building volume while the building is maintained at a pressure difference of 50 Pascals.

**AIR BARRIER MATERIAL.** Material(s) that have an air permeability not to exceed 0.004 cfm/ft<sup>2</sup> under a pressure differential of 0.3 in. water (1.57psf) (0.02 L/s.m<sup>2</sup> @ 75 Pa) when tested in accordance with ASTM E 2178.

**AIR BARRIER SYSTEM.** Material(s) assembled and joined together to provide a barrier to air leakage through the building envelope. An air barrier system is a combination of *air barrier materials* and sealants.

**BPI ENVELOPE PROFESSIONAL.** An individual that has successfully passed the Building Performance Institute written and field examination requirements for the Building Envelope certification.

**CFM25.** Cubic Feet per Minute of measured air flow while the forced air system is maintained at a pressure difference of 25 Pascals (0.1 inches w.p.)

**CFM50.** Cubic Feet per Minute of measured air flow while the building is maintained at a pressure difference of 50 Pascals (0.2 inches w.p.).

**CODE OFFICIAL.** The officer or other designated authority charged with the administration and enforcement of this code, or a duly authorized representative.

**F-FACTOR.** The perimeter heat loss factor for slab-on-grade floors (Btu/h x ft x °F) [W/(m x K)].

**FULLY ENCLOSED ATTIC FLOOR SYSTEM**– The ceiling insulation is enclosed on all six sides by an air barrier system, such as taped drywall below, solid framing joists on the sides, solid blocking on the ends, and solid sheathing on top which totally enclose the insulation. This system provides for full depth insulation over the exterior walls.

**HEAT TRAP.** An arrangement of piping and fittings, such as elbows, or a commercially available heat trap that prevents thermosyphoning of hot water during standby periods.

**HEATED SLAB.** Slab-on-grade construction in which the heating elements, hydronic tubing, or hot air distribution system is in contact with, or placed within or under, the slab.

**HERS RATER.** An individual that has completed training and been certified by RESNET (Residential Energy Services Network) Accredited Rating Provider.

**HUMIDISTAT.** A regulatory device, actuated by changes in humidity, used for automatic control of relative humidity.

**INFILTRATION.** The uncontrolled inward air leakage into a building caused by the pressure effects of wind or the effect of differences in the indoor and outdoor air density or both.

**READILY ACCESSIBLE.** Capable of being reached quickly for operation, renewal or inspection without requiring those to whom ready access is requisite to climb over or remove obstacles or to resort to portable ladders or access equipment (see "Accessible").

**LAMP.** The device in a lighting fixture that provides illumination, typically a bulb, fluorescent tube, or light emitting diode (LED).

**SCREW LAMP HOLDERS.** A lamp base that requires a screw-in-type lamp, such as a compact-fluorescent, incandescent, or tungsten-halogen bulb.

**SEMI-CONDITIONED SPACE** A space indirectly conditioned within the thermal envelope that is not directly heated or cooled. For energy purposes, semi-conditioned spaces are treated as conditioned spaces.

**SERVICE WATER HEATING.** Supply of hot water for purposes other than comfort heating.

**WALL, ABOVE-GRADE** A wall more than 50 percent above grade and enclosing *conditioned space*. This includes between-floor spandrels, peripheral edges of floors, roof and basement knee walls, dormer walls, gable end walls, walls enclosing a mansard roof and skylight shafts.

**WALL, CRAWL SPACE.** The opaque portion of a wall that encloses a crawl space and is partially or totally below grade.

**ZONE.** A space or group of spaces within a building with heating or cooling requirements that are sufficiently similar so that desired conditions can be maintained throughout using a single controlling device.

#### **Modified or updated definitions:**

*Original:*

**ACCESSIBLE.** Signifies access that requires the removal of an access panel or similar removable obstruction.

*Modified:*

**ACCESSIBLE.** Signifies access that requires the removal of an access panel or similar removable obstruction. For energy purposes, ACCESSIBLE means admitting close approach as a result of not being guarded by locked doors, elevation or other effective means (see "Readily accessible").

*Original:*

**ADDITION.** An extension or increase in floor area or height of a building or structure.

*Modified:*

**ADDITION.** An extension or increase in floor area or height of a building or structure. For energy purposes, an extension or increase in the *conditioned space* floor area or height of a building or structure.

*Original:*

**BASEMENT WALL.** The opaque portion of a wall that encloses one side of a basement and has an average below grade wall area that is 50% or more of the total opaque and non-opaque area of that enclosing side.

*Modified:*

**BASEMENT WALL.** The opaque portion of a wall that encloses one side of a basement and has an average below grade wall area that is 50% or more of the total opaque and non-opaque area of that enclosing side. For energy purposes, a wall 50 percent or more below grade and enclosing *conditioned space*.

*Original:*

**BUILDING THERMAL ENVELOPE.** The basement walls, exterior walls, floor, roof, and any other building **elements** that enclose *conditioned spaces*.

*Modified:*

**BUILDING THERMAL ENVELOPE.** The basement walls, exterior walls, floor, roof, and any other building element that enclose *conditioned space*. This boundary also includes the boundary between *conditioned space* and any exempt or unconditioned space.

*Original:*

**LABELED.** *Equipment*, materials or products to which have been affixed a *label*, seal, symbol or other identifying *mark* of a nationally recognized testing laboratory, inspection agency, or other organization as approved by the NC Building Code Council concerned with product evaluation that maintains periodic inspection of the production of the above-*labeled* items and whose labeling indicates either that the *equipment*, material or product meets identified standards or has been tested and found suitable for a specified purpose.

*Modified:*

**LABELED.** Appliances, *Equipment*, materials or products to which have been affixed a *label*, seal, symbol or other identifying *mark* of a nationally recognized testing laboratory, inspection agency, or other organization as approved by the NC Building Code Council concerned with product evaluation that maintains periodic inspection of the production of the above-*labeled* items and whose labeling indicates either that the appliance, *equipment*, material or product meets identified standards or has been tested and found suitable for a specified purpose.

*Original:*

**R-VALUE (THERMAL RESISTANCE).** The inverse of the time rate of heat flow through a building thermal envelope element from one of its bounding surfaces to the other for a unit temperature difference between the two surfaces, under steady state conditions, per unit area ( $h \times ft^2 \times ^\circ F/Btu$ ).

*Modified:*

**R-VALUE (THERMAL RESISTANCE).** The inverse of the time rate of heat flow through a body from one of its bounding surfaces to the other surface for a unit temperature difference between the two surfaces, under steady state conditions, per unit area ( $h \times ft^2 \times ^\circ F/Btu$ ) [ $(m^2 \times K)/W$ ].

*Original:*

**SOLAR HEAT GAIN COEFFICIENT (SHGC).** The solar heat gain through a fenestration or glazing assembly relative to the incident solar radiation ( $Btu/h \times ft^2 \times ^\circ F$ )

*Modified:*

**SOLAR HEAT GAIN COEFFICIENT (SHGC).** The ratio of the solar heat gain entering the space through the fenestration assembly to the incident solar radiation. Solar heat gain includes directly transmitted solar heat and absorbed solar radiation which is then reradiated, conducted or convected into the space. This value is related to the Shading Coefficient (SC) by the formula  $SHGC = 0.87 * SC$ .

CHAPTER 11

ENERGY EFFICIENCY

**SECTION N1101  
SCOPE, GENERAL REQUIREMENTS, AND  
ADDITIONAL DEFINITIONS**

**N1101.1 Scope.** This chapter shall regulate the design and construction of buildings for the effective use of energy. This code is intended to provide flexibility to permit the use of innovative approaches and techniques to achieve the effective use of energy. This code is not intended to prevent the use of any material, method of construction, design or insulating system not specifically prescribed herein, provided that such construction, design or insulating system has been *approved* by the *code official* as meeting the intent of this code.

~~This code is not intended to abridge safety, health or environmental requirements contained in other applicable codes or ordinances.~~

**Exception:** Portions of the building envelope that do not enclose conditioned space.

**N1101.1.2 Existing buildings.** Except as specified in this chapter, this code shall not be used to require the removal, *alteration* or abandonment of, nor prevent the continued use and maintenance of, an existing building or building system lawfully in existence at the time of adoption of this code.

**N1101.1.3 Additions, alterations, renovations or repairs.** Additions, alterations, renovations or repairs to an existing building, building system or portion thereof shall conform to the provisions of this code as they relate to new construction without requiring the unaltered portion(s) of the existing building or building system to comply with this code. Additions, alterations, renovations or repairs shall not create an unsafe or hazardous condition or overload existing building systems. An addition shall be deemed to comply with this code if the addition alone complies or if the existing building and addition comply with this code as a single building.

**Exception:**

1. The following need not comply provided the energy use of the building is not increased:

- a) Storm windows installed over existing fenestration.
  - b) Incidental repairs requiring a new sash or new glazing.
  - c) Existing ceiling, wall or floor cavities exposed during construction provided that these cavities are filled with insulation.
  - d) Construction where the existing roof, wall or floor cavity is not exposed.
2. Converting unconditioned attic space to conditioned attic space. Ceilings shall be insulated to a minimum of R-30, walls shall be insulated to the exterior wall requirements in Table N1102.1 and follow backing requirements in Section N1102.2.12.

**N1101.2 Compliance.** Compliance shall be demonstrated by either meeting the requirements of the *North Carolina Energy Conservation Code* or meeting the requirements of this chapter. Climate zones from Figures N1101.2(1), Figure N1101.2(2) or Table N1101.2 shall be used in determining the applicable requirements from this chapter. Projects shall comply with Sections N1101, N1102.4, N1102.5, and N1103.1, N1103.2.2, N1103.2.3, and N1103.3 through N1103.9 and either:

1. Sections N1102.1 through N1102.3, N1103.2.1 and N1104.1; or
2. North Carolina specific REScheck shall be permitted to demonstrate compliance with this code. Envelope requirements may not be traded off against the use of high efficiency heating and/or cooling equipment. No trade-off calculations are needed for required termite inspection and treatment gaps.

**N1101.2.1 Warm humid counties.** Warm humid counties are identified in Table N1101.2 by an asterisk.

**N1101.2.2 Change in space conditioning.** Any nonconditioned space that is altered to become *conditioned space* shall be required to be brought into full compliance with this code.

**Exception:**

Existing enclosed ceiling, wall or floor cavities comply provided that these cavities are filled with insulation.

**N1101.3 Identification.** Materials, systems and equipment shall be identified in a manner that will allow a determination of compliance with the applicable provisions of this chapter.

**N1101.4 Building thermal envelope insulation.** An *R*-value identification mark shall be applied by the manufacturer to each piece of *building thermal envelope* insulation 12 inches (305 mm) or greater in width. Alternately, the insulation installers shall provide a certification listing the type, manufacturer and *R*-value of insulation installed in each element of the *building thermal envelope*. For blown or sprayed insulation (fiberglass and cellulose), the initial installed thickness, settled thickness, settled *R*-value, installed density, coverage area and number of bags installed shall be *listed* on the certification. For sprayed polyurethane foam (SPF) insulation, the installed thickness of the areas covered and *R*-value of installed thickness shall be *listed* on the certification. The insulation installer shall sign, date and post the certification in a conspicuous location on the job site.

**N1101.4.1 Blown or sprayed roof/ceiling insulation.** The thickness of blown-in or sprayed roof/ceiling insulation (fiberglass or cellulose) shall be written in inches (mm) on markers that are installed at least one for every 300 square feet (28 m<sup>2</sup>) throughout the attic space. The markers shall be affixed to the trusses or joists and marked with the minimum initial installed thickness with numbers a minimum of 1 inch (25 mm) in height. Each polyurethane foam thickness and installed *R*-value shall be *listed* on certification provided by the insulation installer.

**N1101.4.2 Insulation mark installation.** Insulating materials shall be installed such that the manufacturer's *R*-value mark is readily observable upon inspection.

**N1101.5 Fenestration product rating.** *U*-factors of fenestration products (windows, doors and skylights) shall be determined in accordance with NFRC 100 by an accredited, independent laboratory, and labeled and certified by the manufacturer. Products lacking such a labeled *U*-factor shall be assigned a default *U*-factor from Tables N1101.5(1) or N1101.5(2). The solar heat gain coefficient (SHGC) of glazed fenestration products (windows, glazed doors and

skylights) shall be determined in accordance with NFRC 200 by an accredited, independent laboratory, and labeled and certified by the manufacturer. Products lacking such a labeled SHGC shall be assigned a default SHGC from Table N1101.5(3).

**N1101.6 Insulation product rating.** The thermal resistance (*R*-value) of insulation shall be determined in accordance with the U.S. Federal Trade Commission *R*-value rule (CFR Title 16, Part 460, May 31, 2005) in units of h x ft<sup>2</sup> x °F/Btu at a mean temperature of 75°F (24°C).

**N1101.7 Installation.** All materials, systems and equipment shall be installed in accordance with the manufacturer's installation instructions and this code.

**N1101.7.1 Protection of exposed foundation insulation.** Insulation applied to the exterior of basement walls, crawlspace walls and the perimeter of slab-on-grade floors shall have a rigid, opaque and weather-resistant protective covering to prevent the degradation of the insulation's thermal performance. The protective covering shall cover the exposed exterior insulation and extend a minimum of 6 inches (153 mm) below grade.

**N1101.8 Above code programs.**  
Deleted

**N1101.9 Certificate.** A permanent certificate shall be posted on or in the electrical distribution panel, in the attic next to the attic insulation card, or inside a kitchen cabinet or other approved location. The certificate shall not cover or obstruct the visibility of the circuit directory label, service disconnect label or other required labels. The builder, permit holder, or registered design professional shall be responsible for completing the certificate. The certificate shall list the predominant *R*-values of insulation installed in or on ceiling/roof, walls, foundation (slab, *basement wall*, crawlspace wall and/or floor) and ducts outside conditioned spaces; *U*-factors for fenestration and the solar heat gain coefficient (SHGC) of fenestration.

Where there is more than one value for each component, the certificate shall list the value covering the largest area. The certificate shall indicate whether the building air leakage was visually inspected as required in N1102.4.2.1 or provide results of the air leakage testing required in N1102.4.2.2. The certificate shall provide results of duct leakage test required in N1102.4.2.2. Appendix E-1 contains a sample certificate.

**N1101.10 Additional Voluntary Criteria for Increasing Residential Energy Efficiency.**

Appendix E-4 contains additional voluntary measures for increasing residential energy efficiency beyond code minimums. Implementation of the increased energy efficiency measures is strictly voluntary at the option of the permit holder. The sole purpose of the appendix is to provide guidance for achieving

additional residential energy efficiency improvements that have been evaluated to be those that are most cost effective for achieving an additional 15-20% improvement in energy efficiency beyond code minimums.

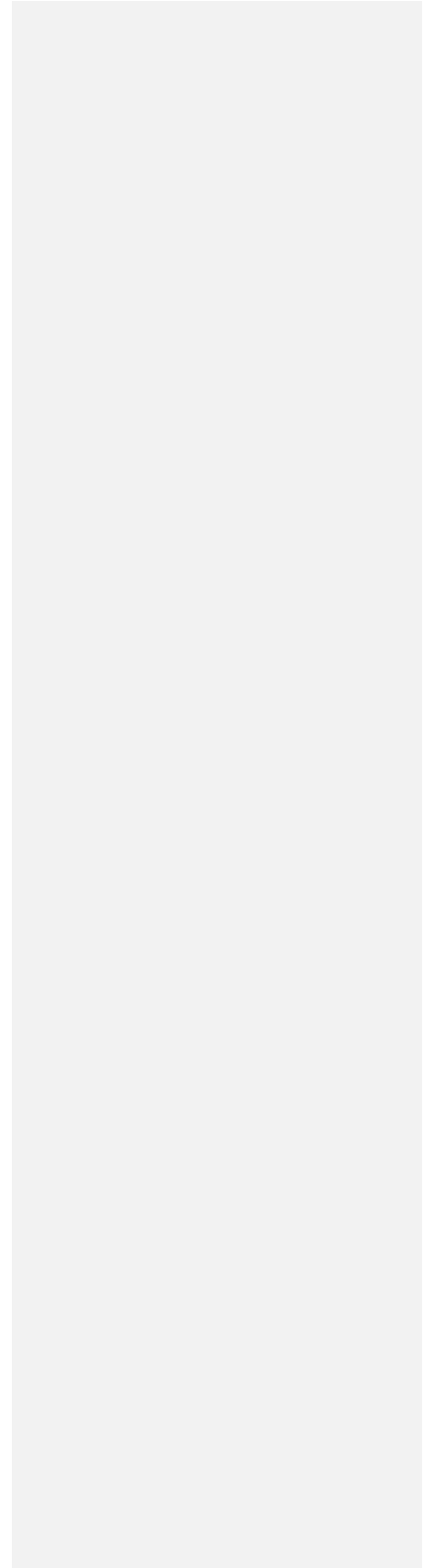

**TABLE N1101.2  
NORTH CAROLINA CLIMATE ZONES, MOISTURE REGIMES, AND WARM-HUMID DESIGNATIONS  
BY COUNTY**

**Key: A – Moist, B – Dry, C – Marine. Absence of moisture designation indicates moisture regime is irrelevant. Asterisk (\*) indicates a warm-humid location.**

**NORTH  
CAROLINA**

4A Alamance	3A Edgecombe	4A Orange
4A Alexander	4A Forsyth	3A Pamlico
5A Alleghany	4A Franklin	3A Pasquotank
3A Anson	3A Gaston	3A Pender*
5A Ashe	4A Gates	3A Perquimans
5A Avery	4A Graham	4A Person
3A Beaufort	4A Granville	3A Pitt
4A Bertie	3A Greene	4A Polk
3A Bladen	4A Guilford	3A Randolph
3A Brunswick*	4A Halifax	3A Richmond
4A Buncombe	4A Harnett	3A Robeson
4A Burke	4A Haywood	4A Rockingham
3A Cabarrus	4A Henderson	3A Rowan
4A Caldwell	4A Hertford	4A Rutherford
3A Camden	3A Hoke	3A Sampson
3A Carteret*	3A Hyde	3A Scotland
4A Caswell	4A Iredell	3A Stanly
4A Catawba	4A Jackson	4A Stokes
4A Chatham	3A Johnston	4A Surry
4A Cherokee	3A Jones	4A Swain
3A Chowan	4A Lee	4A Transylvania
4A Clay	3A Lenoir	3A Tyrrell
4A Cleveland	4A Lincoln	3A Union
3A Columbus*	4A Macon	4A Vance
3A Craven	4A Madison	4A Wake
3A Cumberland	3A Martin	4A Warren
3A Currituck	4A McDowell	3A Washington
3A Dare	3A Mecklenburg	5A Watauga
3A Davidson	5A Mitchell	3A Wayne
4A Davie	3A Montgomery	4A Wilkes
3A Duplin	3A Moore	3A Wilson
4A Durham	4A Nash	4A Yadkin
	3A New Hanover*	5A Yancey
	4A Northampton	
	3A Onslow*	

Formatted: English (U.S.)

Formatted: Portuguese (Brazil)

Formatted: Portuguese (Brazil)

Formatted: English (U.S.)

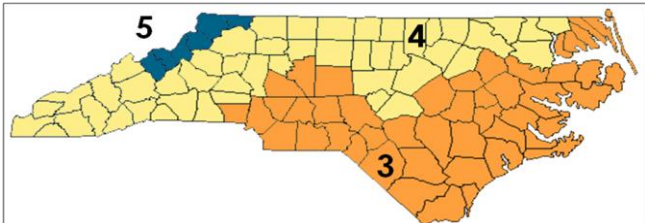

**Figure N1101.2(1) North Carolina Climate Zones**

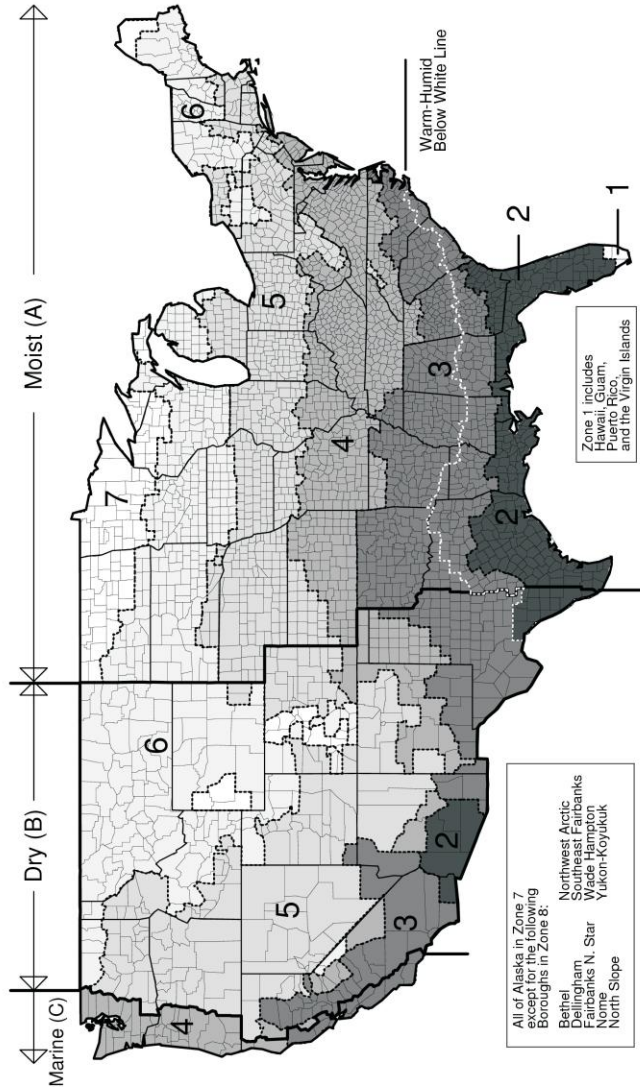
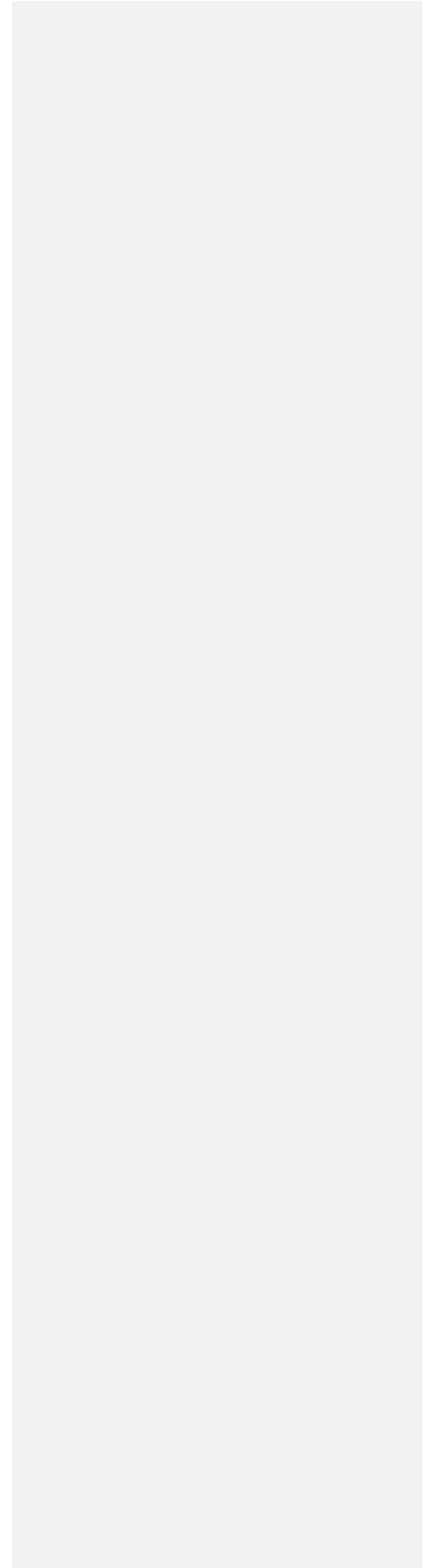

Figure N1101.2(2) Climate Zones





**TABLE N1101.5(1)  
DEFAULT GLAZED FENESTRATION U-FACTOR**

FRAME TYPE	SINGLE PANE	DOUBLE PANE	SKYLIGHT	
			Single	Double
Metal	1.20	0.80	2.00	1.30
Metal with Thermal Break	1.10	0.65	1.90	1.10
Nonmetal or Metal Clad	0.95	0.55	1.75	1.05
Glazed Block	0.60			

**TABLE N1101.5(2)  
DEFAULT DOOR U-FACTORS**

DOOR TYPE	U-FACTOR
Uninsulated Metal	1.20
Insulated Metal	0.60
Wood	0.50
Insulated, nonmetal edge, max 45% glazing, any glazing double pane	0.35

**TABLE N1101.5(3)  
DEFAULT GLAZED FENESTRATION SHGC**

SINGLE GLAZED		DOUBLE GLAZED		GLAZED BLOCK
Clear	Tinted	Clear	Tinted	
0.8	0.7	0.7	0.6	0.6

**SECTION N1102  
BUILDING THERMAL ENVELOPE**

**N1102.1 Insulation and fenestration criteria.** The *building thermal envelope* shall meet the requirements of Table N1102.1 based on the climate zone specified in Table N1101.2.

**N1102.1.1 R-value computation.** Insulation material used in layers, such as framing cavity insulation and insulating sheathing, shall be summed to compute the component *R*-value. The manufacturer's settled *R*-value shall be used for blown insulation. Computed *R*-values shall not include an *R*-value for other building materials or air films.

**N1102.1.2 U-factor alternative.** An assembly with a *U*-factor equal to or less than that specified in Table

N1102.1.2 shall be permitted as an alternative to the *R*-value in Table N1102.1.

**N1102.1.3 Total UA alternative.** If the total *building thermal envelope* UA (sum of *U*-factor times assembly area) is less than or equal to the total UA resulting from using the *U*-factors in Table N1102.1.2 (multiplied by the same assembly area as in the proposed building), the building shall be considered in compliance with Table N1102.1. The UA calculation shall be done using a method consistent with the *ASHRAE Handbook of Fundamentals* and shall include the thermal bridging effects of framing materials. The SHGC requirements shall be met in addition to UA compliance.

**TABLE N1102.1  
INSULATION AND FENESTRATION REQUIREMENTS BY COMPONENT<sup>a</sup>**

CLIMATE ZONE	FENESTRATION U-FACTOR <sup>b</sup>	SKYLIGHT <sup>b</sup> U-FACTOR	GLAZED FENESTRATION SHGC <sup>b,e</sup>	CEILING R-VALUE <sup>k</sup>	WOOD FRAME WALL R-VALUE <sup>o</sup>	MASS WALL R-VALUE <sup>i</sup>	FLOOR R-VALUE	BASEMENT <sup>c</sup> WALL R-VALUE	SLAB <sup>d</sup> R-VALUE	CRAWL SPACE <sup>c</sup> WALL R-VALUE
3	<u>0.35</u>	0.65	<u>0.30</u>	<u>30</u>	<u>13</u>	5/10	19	10/13 <sup>r</sup>	<u>0</u>	<u>5/13</u>
4	<u>0.35</u>	0.60	<u>0.30</u>	<u>38 or 30 cont.</u> <sup>j</sup>	<u>15, 13+2.5<sup>h</sup></u>	5/10	19	10/13	10 <sup>d</sup>	10/13
5	<u>0.35</u>	0.60	NR	<u>38 or 30 cont.</u> <sup>j</sup>	19, 13+5, or 15+3 <sup>ch</sup>	13/17	30 <sup>g</sup>	10/13	10 <sup>d</sup>	<u>10/13</u>
3	<u>0.32</u>	0.65	0.27	42	19, 13+5, or 15+3 <sup>ch</sup>	5/40	19	10/13 <sup>c</sup>	5, 2-ft	40/13
4	0.32	0.60	0.27	42	19, 13+5, or 15+3 <sup>ch</sup>	5/40	19	10/13	10, 2-ft	40/13
5	0.32	0.60	NR	42	19, 13+5, or 15+3 <sup>ch</sup>	13/17	30 <sup>g</sup>	10/13	10, 2-ft	15/19

For SI: 1 foot = 304.8 mm.

a. R-values are minimums. U-factors and SHGC are maximums.

b. The fenestration U-factor column excludes skylights. The SHGC column applies to all glazed fenestration.

c. "10/13" means R-10 continuous insulated sheathing on the interior or exterior of the home or R-13 cavity insulation at the interior of the basement wall or crawl space wall.

d. For monolithic slabs, insulation shall be applied from the inspection gap downward to the bottom of the footing **or a maximum of 18 inches below grade whichever is less**. For floating slabs, insulation shall extend to the bottom of the foundation wall or 24 inches, whichever is less. (See Appendix O) R-5 shall be added to the required slab edge R-values for heated slabs.

e.- R-19 fiberglass batts compressed and installed in a nominal 2 x 6 framing cavity is deemed to comply. Fiberglass batts rated R-19 or higher compressed and installed in a 2x4 wall is not deemed to comply.

f. Basement wall insulation is not required in warm-humid locations as defined by Figure N1101.2(1 and 2) and Table N1101.2.

g. Or insulation sufficient to fill the framing cavity, R-19 minimum.

h. "13+5" means R-13 cavity insulation plus R-5 insulated sheathing. 15+3 means R-15 cavity insulation plus R-3 insulated sheathing. If structural sheathing covers 25 percent or less of the exterior, insulating sheathing is not required where structural sheathing is used. If structural sheathing covers more than 25 percent of exterior, structural sheathing shall be supplemented with insulated sheathing of at least R-2. 13+2.5 means R-13 cavity insulation plus R-2.5 sheathing.

i. For Mass Walls, the second R-value applies when more than half the insulation is on the interior of the mass wall.

**j. R-30 shall be deemed to satisfy the ceiling insulation requirement wherever the full height of uncompressed R-30 insulation extends over the wall top plate at the eaves. Otherwise R-38 insulation is required where adequate clearance exists or insulation must extend to either the insulation baffle or within 1" of the attic roof deck.**

k. Table value required except for roof edge where the space is limited by the pitch of the roof, there the insulation must fill the space up to the air baffle.

## N1102.2 Specific insulation requirements

### N1102.2.1 Ceilings with attic spaces. Ceilings with attic spaces over conditioned space shall meet the insulation requirements in Table N1102.1.

#### Exceptions:

- 1) When insulation is installed in a *fully enclosed attic floor system*, as described in Appendix E 2.1, R-30 shall be deemed compliant.
- 2) In roof edge and other miscellaneous details such as bay windows, dormers, and similar areas where the space is limited, the insulation must fill the space up to the air baffle.

**N1102.2.2 Ceilings without attic spaces.** Where the design of the roof/ceiling assembly, including cathedral ceilings, bay windows and other similar miscellaneous areas, does not allow sufficient space for the required insulation, the minimum required insulation for such roof/ceiling assemblies shall be R-30. This reduction of insulation from the requirements of Section N1102.1 shall be limited to 500 square feet (46m<sup>2</sup>) of ceiling surface area. This reduction shall not apply to the *U-factor* alternative approach in Section N1102.1.2 and the total UA alternative in Section N1102.1.3.

**N1102.2.3 Access hatches and doors.** Horizontal access doors from conditioned spaces to unconditioned spaces (e.g., attics and crawl spaces) shall be weatherstripped and insulated to an R-10 minimum value, and vertical doors to such spaces shall be weatherstripped and insulated to R-5.

Access shall be provided to all equipment that prevents damaging or compressing the insulation. A wood framed or equivalent baffle or retainer is required to be provided when loose fill insulation is installed, the purpose of which is to prevent the loose fill insulation from spilling into the living space when the attic access is opened, and to provide a permanent means of maintaining the installed *R-value* of the loose fill insulation.

**Exceptions:** 1) Pull down stair systems shall be weatherstripped and insulated to an R-5 insulation value such that the insulation does not interfere with proper operation of the stair. Non-rigid insulation materials are not allowed. Additional insulation systems that enclose the stair system from above are allowed. Exposed foam plastic must meet the provisions of the *North Carolina Residential Code*.

- 2) Full size doors that are part of the building thermal envelope and provide a passageway to unconditioned spaces shall meet the requirements of exterior doors in Section N1102.3.4.

**N1102.2.4 Mass walls.** Mass walls for the purposes of this chapter shall be considered above-grade walls of concrete block, concrete, insulated concrete form (ICF), masonry cavity, brick (other than brick veneer), earth (adobe, compressed earth block, rammed earth) and solid timber/logs.

**N1102.2.5 Steel-frame ceilings, walls, and floors.** Steel-frame ceilings, walls and floors shall meet the insulation requirements of Table N1102.2.5 or shall meet the *U-factor* requirements in Table N1102.1.2. The calculation of the *U-factor* for a steel-frame envelope assembly shall use a series-parallel path calculation method.

**N1102.2.6 Floors.** Floor insulation shall be installed to maintain permanent contact with the underside of the subfloor decking. The distance between tension support wires or other devices that hold the floor insulation in place against the subfloor shall be no more than 18 inches. In addition, supports shall be located no further than 6 inches from each end of the insulation.

**Exception:** Enclosed floor cavity such as garage ceilings, cantilevers or buildings on pilings with enclosed floor cavity with the insulation fully in contact with the lower air barrier. In this case, the band boards shall be fully insulated to maintain thermal envelope continuity.

**N1102.2.7 Basement walls.** Walls associated with conditioned basements shall be insulated from the top of the *basement wall* down to 10 feet (3048 mm) below *grade* or to the basement floor, whichever is less. Walls associated with unconditioned basements shall meet this requirement unless the floor overhead is insulated in accordance with Sections N1102.1 and N1102.2.6.

**N1102.2.8 Slab-on-grade floors.** Slab-on-grade floors with a floor surface less than 12 inches (305 mm) below grade shall be insulated in accordance with Table N1102.1. The top edge of the insulation installed between the *exterior wall* and the edge of

the interior slab shall be permitted to be cut at a 45-degree (0.79 rad) angle away from the *exterior wall*. Slab edge insulation shall have 2" termite inspection gap consistent with Appendix O of this code.

**TABLE N1102.1.2  
EQUIVALENT U-FACTORS<sup>a</sup>**

CLIMATE ZONE	FENESTRATION U-FACTOR	SKYLIGHT U-FACTOR	CEILING U-FACTOR	FRAME WALL U-FACTOR	MASS WALL U-FACTOR <sup>b</sup>	FLOOR U-FACTOR	BASEMENT WALL U-FACTOR <sup>d</sup>	CRAWL SPACE WALL U-FACTOR <sup>c</sup>
3	0.35	0.65	0.035	0.082	0.141	0.047	0.059	0.136
4	0.35	0.60	0.030	0.071	0.141	0.047	0.059	0.065
5	0.35	0.60	0.030	0.067	0.082	0.033	0.059	0.065

- a. Nonfenestration *U*-factors shall be obtained from measurement, calculation or an approved source.
- b. When more than half the insulation is on the interior, the mass wall *U*-factors shall be a maximum 0.12 in Zone 3, 0.10 in Zone 4, and the same as the frame wall *U*-factor in Zone 5.
- c. Basement wall *U*-factor of 0.360 in warm-humid locations as defined by Figures N1101.2(1), N1101.2(2) and Table N1101.2.
- d. Foundation *U*-factor requirements shown in Table N1102.1.2 include wall construction and interior air films but exclude soil conductivity and exterior air films. *U*-factors for determining code compliance in accordance with Section N1102.1.3 (total UA alternative) shall be modified to include soil conductivity and exterior air films.

**TABLE N1102.2.5  
STEEL-FRAME CEILING, WALL AND FLOOR INSULATION  
(R-VALUE)**

WOOD FRAME R-VALUE REQUIREMENT	COLD-FORMED STEEL EQUIVALENT R-VALUE <sup>a</sup>
<b>Steel Truss Ceilings<sup>b</sup></b>	
R-30	R - 38 or R - 30 + 3 or R - 26 + 5
R-38	R - 49 or R - 38 + 3
R-49	R-38+5
<b>Steel Joist Ceilings<sup>b</sup></b>	
R-30	R - 38 in 2x4 or 2x6 or 2x8 R - 49 in any framing
R-38	R - 49 in 2x4 or 2x6 or 2x8 or 2x10
<b>Steel Framed Wall</b>	
R-13	R - 13 + 5 or R - 15 + 4 or R - 21 + 3 or R - 0 + 10
R-19	R - 13 + 9 or R - 19 + 8 or R - 25 + 7
R-21	R - 13 + 10 or R - 19 + 9 or R - 25 + 8
<b>Steel Joist Floor</b>	
R-13	R - 19 in 2x6 R - 19 + 6 in 2x8 or 2x10
R-19	R - 19 + 6 in 2x6 R - 19 + 12 in 2x8 or 2x10

- a. Cavity insulation *R*-value is listed first, followed by continuous insulation *R*-value.
- b. Insulation exceeding the height of the framing shall cover the framing.

**N1102.2.9 Closed crawl space walls.**

Where the floor above a closed crawl space is not insulated, the exterior crawlspace walls shall be insulated in accordance with table 1102.1. Wall insulation may be located in any combination of the outside and inside wall surfaces and within the structural cavities or materials of the wall system. Wall insulation requires that the exterior wall band joist area of the floor frame be insulated. Wall insulation shall begin 3 inches (76.2mm) below the top of the masonry foundation wall and shall extend

down to 3 inches (76.2mm) above the top of the footing or concrete floor, 3 inches(76.2mm ) above the interior ground surface or 24 inches (609.6mm) below the outside finished ground level, whichever is less. (See Appendix E-2.2 details)

Termite inspection, clearance, and wicking gaps are allowed in wall insulation systems. Insulation may be omitted in the gap area without energy penalty. The allowable insulation gap widths are listed in Table N1102.2.9. If gap width exceeds the

Formatted: Portuguese (Brazil)

allowances, one of the following energy compliance options shall be met:

1. Wall insulation is not allowed and the required insulation value shall be provided in the floor system.
2. Compliance shall be demonstrated with energy trade-off methods provided by a North Carolina-specific version of RESCHECK

**TABLE N1102.2.9  
WALL INSULATION ALLOWANCES FOR TERMITE  
TREATMENT AND INSULATION GAPS**

Maximum Gap Width(inches)	Insulation Location	Gap Description
3	Outside	Above grade inspection between top of insulation and bottom of siding
6	Outside	Below grade treatment
4a	Inside	Wall inspection between top of insulation and bottom of sill
4a	Inside	Clearance / wicking space between bottom of insulation and top of ground surface, footing, or concrete floor.

For si 1 inch = 25.4mm

a. No insulation shall be required on masonry wall of 9 inches in height or less.

**N1102.2.10 Masonry veneer.** Insulation shall not be required on the horizontal portion of the foundation that supports a masonry veneer.

**N1102.2.11 Thermally isolated conditioned sunroom insulation.** The minimum ceiling insulation *R*-values shall be *R*-19 in Zones 3 and 4, and *R*-24 in Zone 5. The minimum wall *R*-value shall be *R*-13. New wall(s) separating a sunroom from *conditioned space* shall meet the *building thermal envelope* requirements. Floor and slab insulation shall comply with values in Table N1102.1.1.

**N1102.2.12 Framed cavity walls.** The exterior thermal envelope wall insulation shall be installed in substantial contact and continuous alignment with the building envelope air barrier. Insulation shall be substantially free from installation gaps, voids, or compression. For framed walls, the cavity insulation shall be enclosed on all sides with a rigid material or an air barrier material. Wall insulation shall be enclosed at the following locations when installed on exterior walls prior to being covered by subsequent construction, consistent with the Appendix E-2.3 of this code:

1. Tubs
2. Showers

3. Stairs
4. Fireplace units

Enclosure of wall cavity insulation also applies to walls that adjoin attic spaces **by placing a rigid material or air barrier material** on the attic space side of the wall on the attic space side of the wall.

**N1102.3 Fenestration.**

**N1102.3.1 U-factor.** An area-weighted average of fenestration products shall be permitted to satisfy the *U*-factor requirements.

**N1102.3.2 Glazed fenestration SHGC.** An area-weighted average of fenestration products more than 50 percent glazed shall be permitted to satisfy the SHGC requirements.

**N1102.3.3 Glazed fenestration exemption.** Up to 15 square feet (1.4m<sup>2</sup>) of glazed fenestration per dwelling unit shall be permitted to be exempt from *U*-factor and SHGC requirements in Section N1102.1. This exemption shall not apply to the *U*-factor alternative approach in Section N1102.1.2 and the Total UA alternative in Section N1102.1.3.

**N1102.3.4 Opaque door.** Opaque doors separating conditioned and unconditioned space shall have a maximum *U*-factor of 0.35.

**Exception:** One side-hinged opaque door assembly up to 24 square feet (2.22 m<sup>2</sup>) in area is exempted from the *U*-factor requirement in Section N1102.1. This exemption shall not apply to the *U*-factor alternative approach in Section N1102.1.2 and the Total UA alternative in Section N1102.1.3.

**N1102.3.5 Thermally isolated conditioned sunroom U-factor and SHGC.** The maximum fenestration *U*-factor shall be 0.40 and the maximum skylight *U*-Factor shall be 0.75. Sunrooms with cooling systems shall have a maximum fenestration SHGC of 0.40 for all glazing.

New windows and doors separating the sunroom from conditioned space shall meet the building thermal envelope requirements. Sunroom additions shall maintain thermal isolation; and shall be served by a separate heating or cooling system, or be thermostatically controlled as a separate zone of the existing system.

**N1102.3.6 Replacement fenestration.** Where an entire existing fenestration unit is replaced with a

new fenestration product, including frame, sash and glazing, the replacement fenestration unit shall meet the applicable requirements for *U*-factor and SHGC in Table N1102.1.

#### **N1102.4 Air leakage control**

**N1102.4.1 Building thermal envelope.** The *building thermal envelope* shall be durably sealed with an air barrier system to limit infiltration. The sealing methods between dissimilar materials shall allow for differential expansion and contraction. For all homes, where present, the following shall be caulked, gasketed, weatherstripped or otherwise sealed with an air barrier material or solid material consistent with Appendix E-2.4 of this code:

1. Blocking and sealing floor/ceiling systems and under knee walls open to unconditioned or exterior space.
2. Capping and sealing shafts or chases, including flue shafts.
3. Capping and sealing soffit or dropped ceiling areas.

**N1102.4.2 Air sealing.** Building envelope air tightness shall be demonstrated by Section N1102.4.2.1 or N1102.4.2.2. Appendix E-3 contains optional sample worksheets for visual inspection or testing for the permit holder's use only.

**N1102.4.2.1 Visual inspection option.** Building envelope tightness shall be considered acceptable when items providing insulation enclosure in N1102.2.12 and air sealing in N1102.4.1 are addressed and when the items listed in Table N1102.4.2, applicable to the method of construction, are certified by the builder, permit holder or registered design professional via the certificate in Appendix E-1.

**N1102.4.2.2 Testing option.** Building envelope tightness shall be considered acceptable when items providing insulation enclosure in N1102.2.12 and air sealing in N1102.4.1 are addressed and when tested air leakage is less than or equal to one of the two following performance measurements:

1. **0.30** CFM50/Square Foot of Surface Area (SFSA) or
2. **Five** (5) air changes per hour (ACH50)

when tested with a blower door fan assembly, at a pressure of 33.5 psf (50 Pa). A single point depressurization, not temperature corrected, test is sufficient to comply with this provision, provided that the blower door fan assembly has been certified

by the manufacturer to be capable of conducting tests in accordance with ASTM E779-03. Testing shall occur after rough in and after installation of penetrations of the building envelope, including penetrations for utilities, plumbing, electrical, ventilation and combustion appliances. Testing shall be reported by the permit holder, a NC licensed general contractor, a NC licensed HVAC contractor, a NC licensed Home Inspector, a registered design professional, a *certified BPI Envelope Professional* or a *certified HERS rater*.

During testing:

1. Exterior windows and doors, fireplace and stove doors shall be closed, but not sealed;
2. Dampers shall be closed, but not sealed, including exhaust, backdraft, and flue dampers;
3. Interior doors shall be open;
4. Exterior openings for continuous ventilation systems, air intake ducted to the return side of the conditioning system, and energy or heat recovery ventilators shall be closed and sealed;
5. Heating and cooling system(s) shall be turned off; and
6. Supply and return registers shall not be sealed.

The air leakage information, including building air leakage result, tester name, date, and contact information, shall be included on the certificate described in Section N1101.9.

For Test Criteria 1 above, the report shall be produced in the following manner: perform the blower door test and record the *CFM50*. Calculate the total square feet of surface area for the building thermal envelope (all floors, ceilings, and walls, including windows and doors, bounding conditioned space) and record the area. Divide *CFM50* by the total square feet and record the result. If the result is less than or equal to [**0.30 CFM50/SFSA**] the envelope tightness is acceptable; or

For Test Criteria 2 above, the report shall be produced in the following manner: Perform a blower door test and record the *CFM50*. Multiply the *CFM50* by 60 minutes to create *CFHour50* and record. Then calculate the total conditioned volume of the home and record. Divide the *CFHour50* by the total volume and record the result. If the result is less than or equal to [**5 ACH50**] the envelope tightness is acceptable

**TABLE N1102.4.2  
AIR BARRIER INSPECTION**

COMPONENT	CRITERIA
Ceiling/attic	Sealants or gaskets provide a continuous air barrier system joining the top plate of framed walls with either the ceiling drywall or the top edge of wall drywall to prevent air leakage.  Top plate penetrations are sealed.  For ceiling finishes that are not air barrier systems such as tongue-and-groove planks, air barrier systems,(for example, taped house wrap), shall be used above the finish  Note: It is acceptable that sealants or gaskets applied as part of the application of the drywall will not be observable by the code official.
Walls	Sill plate is gasketed or sealed to subfloor or slab.
Windows and doors	Space between window and exterior door jambs and framing is sealed.
Floors (including above-garage and cantilevered floors)	Air barrier system is installed at any exposed edge of insulation.
Penetrations	Utility penetrations through the building thermal envelope, including those for plumbing, electrical wiring, ductwork, security and fire alarm wiring, and control wiring, shall be sealed.
Garage separation	Air sealing is provided between the garage and conditioned spaces. An air barrier system shall be installed between the ceiling system above the garage and the ceiling system of interior spaces.
Duct boots	Sealing HVAC register boots and return boxes to subfloor or drywall.
Recessed lighting	Recessed light fixtures are air tight, IC rated, and sealed to drywall. <b>Exception</b> —fixtures not penetrating the building envelope.

**N1102.4.3 Fireplaces.** Site-built masonry ~~solid-fuel-burning~~ fireplaces shall have doors and comply with Section R1006 of the North Carolina Residential Code for combustion air.

**N1102.4.4 Fenestration air leakage.** Windows, skylights and sliding glass doors shall have an air infiltration rate of no more than 0.3 cfm per square foot (1.5 L/s/m<sup>2</sup>), and swinging doors no more than 0.5 cfm per square foot (2.6 L/s/m<sup>2</sup>), when tested according to NFRC 400 or AAMA/WDMA/CSA 101/I.S.2/A440 by an accredited, independent laboratory and *listed* and *labeled* by the manufacturer.

**Exception:** Site-built windows, skylights and doors.

**N1102.4.5 Recessed lighting.** Recessed luminaires installed in the *building thermal envelope* shall be sealed to limit air leakage between conditioned and unconditioned spaces. All recessed luminaires shall be IC-rated and *labeled* as meeting ASTM E 283

when tested at 1.57 psf (75 Pa) pressure differential with no more than 2.0 cfm (0.944 L/s) of air movement from the *conditioned space* to the ceiling cavity. All recessed luminaires shall be sealed with a gasket or caulk between the housing and the interior wall or ceiling covering.

**N1102.5 Maximum fenestration U-factor and SHGC**

The area-weighted average maximum fenestration *U*-factor permitted using trade-offs from Section 1102.1.4 shall be 0.40. Maximum skylight *U*-factors shall be 0.65 in zones 4 and 5 and 0.60 in zone 3.

## SECTION N1103 SYSTEMS

**N1103.1 Controls.** At least one thermostat shall be provided for each separate heating and cooling system.

**N1103.1.1 Programmable thermostat.** Where the primary heating system is a forced-air furnace, at least one thermostat per dwelling unit shall be capable of controlling the heating and cooling system on a daily schedule to maintain different temperature set points at different times of the day. This thermostat shall include the capability to set back or temporarily operate the system to maintain zone temperatures down to 55°F (13°C) or up to 85°F (29°C).

**N1103.1.2 Heat pump supplementary heat.** Heat pumps having supplementary electric-resistance heat shall have controls that, except during defrost, prevent supplemental heat operation when the heat pump compressor can meet the heating load.

A heat strip outdoor temperature lockout shall be provided to prevent supplemental heat operation in response to the thermostat being changed to a warmer setting. The lockout shall be set no lower than 35°F and no higher than 40°F.

**1103.1.3 Maintenance information.** Maintenance instructions shall be furnished for equipment and systems that require preventive maintenance.

~~Required regular maintenance actions shall be clearly stated and incorporated on a readily accessible label. The label shall include the title or publication number for the operation and maintenance manual for that particular model and type of product.~~

### N1103.2 Ducts.

**N1103.2.1 Insulation.** Supply and return ducts in unconditioned space and outdoors shall be insulated to R-8. Supply ducts inside semiconditioned space shall be insulated to R-4; return ducts inside conditioned and semi-conditioned space are not required to be insulated. Ducts located inside conditioned space are not required to be insulated other than as may be necessary for preventing the formation of condensation on the exterior of cooling ducts.

**N1103.2.2 Sealing** All ducts, air handlers, filter boxes and building cavities used as ducts shall be sealed. Joints and seams shall comply with Part V –

Mechanical, Section 603.9 of the *North Carolina Residential Code*.

Duct tightness shall be verified as follows:

Total duct leakage less than or equal to **6** CFM (18 L/min) per 100 ft<sup>2</sup> (9.29 m<sup>2</sup>) of *conditioned floor area* served by that system when tested at a pressure differential of 0.1 inches w.g. (25 Pa) across the entire system, including the manufacturer's air handler enclosure.

During testing:

1. Block, if present, the ventilation air duct connected to the conditioning system.
2. The duct air leakage testing equipment shall be attached to the largest return in the system or to the air handler.
3. The filter shall be removed and the air handler power shall be turned off.
4. Supply boots or registers and return boxes or grilles shall be taped, plugged, or otherwise sealed air tight.
5. The hose for measuring the 25 Pascals of pressure differential shall be inserted into the boot of the supply that is nominally closest to the air handler.
6. Specific instructions from the duct testing equipment manufacturer shall be followed to reach duct test pressure and measure duct air leakage.

Testing shall be performed and reported by the permit holder, a NC licensed general contractor, a NC licensed HVAC contractor, a NC licensed Home Inspector, a registered design professional, a certified BPI Envelope Professional or a certified HERS rater. A single point depressurization, not temperature corrected, test is sufficient to comply with this provision, provided that the duct testing fan assembly has been certified by the manufacturer to be capable of conducting tests in accordance with ASTM E1554-07.

The duct leakage information, including duct leakage result, tester name, date, and contact information, shall be included on the certificate described in Section N1101.9.

For the Test Criteria, the report shall be produced in the following manner: perform the HVAC system air leakage test and record the CFM25. Calculate the total square feet of Conditioned Floor Area (CFA) served by that system. **Multiply the CFM25 by 100, then divide by the Conditioned Floor Area to find the CFM25/100SF and record the result.** If the result is



less than or equal to [6CFM25/100 SF] the HVAC system air tightness is acceptable. Appendix E-3C contains optional sample worksheets for duct testing for the permit holder's use only.

**Exceptions to testing requirements:**

1. Duct systems or portions thereof inside the building thermal envelope shall not be required to be leak tested.
2. Installation of a partial system as part of replacement, renovation or addition does not require a duct leakage test.

**N1103.2.3 Building cavities.** Building framing cavities shall not be used as supply ducts.

**N1103.3 Mechanical system piping insulation.** Mechanical system piping capable of carrying fluids above 105°F (41°C) or below 55°F (13°C) shall be insulated to a minimum of R-3.

**N1103.4 Circulating hot water systems.** All circulating service hot water piping shall be insulated to at least R-2. Circulating hot water systems shall include an automatic or readily *accessible* manual switch that can turn off the hot water circulating pump when the system is not in use.

**N1103.5 Mechanical ventilation.** Exhausts shall have automatic or gravity dampers that close when the ventilation system is not operating.

**N1103.6 Equipment sizing and efficiency.**

**N1103.6.1 Equipment Sizing.** Heating and cooling equipment shall be sized in accordance with the mechanical section of the North Carolina Residential Code.

**N1103.6.2 Equipment Efficiencies.** Equipment efficiencies shall comply with the current NAECA minimum standards.

**N1103.7 Snow melt system controls.** Snow- and ice-melting systems, supplied through energy service to the building, shall include automatic controls capable of shutting off the system when the pavement temperature is above 50°F, and no precipitation is falling and an automatic or manual control that will allow shutoff when the outdoor temperature is above 40°F.

**N1103.8 Pools, inground permanently installed spas (Mandatory).** Pools and inground permanently installed spas shall be provided with energy-conserving measures in accordance with Sections N1103.8.1 through N1103.8.3.

**N1103.8.1 Pool Heaters.** All heaters shall be equipped with a readily accessible on-off switch that is mounted outside of the heater to allow shutting off the heater without adjusting the thermostat setting. Gas-fired heaters shall not be equipped with constant burning pilot lights.

**N1103.8.2 Time switches.** Time switches or other control methods that can automatically turn off and on heaters and pumps according to a preset schedule shall be installed on all swimming pool heaters and pumps. Heaters, pumps and motors that have built-in timers shall be deemed in compliance with this requirement.

**Exceptions:**

1. Where public health standards require 24-hour pump operation.
2. Where pumps are required to operate solar- and waste-heat-recovery pool heating systems.

**N1103.8.3 Pool covers.** Heated pools and inground permanently installed spas shall be equipped provided with a vapor-retardant pool cover on or at the water surface. Pools heated to more than 90°F (32°C) shall have a pool cover with a minimum insulation value of R-12.

**Exception:** Pools deriving over 70 60 percent of the energy for heating from site-recovered energy, such as a heat pump or solar energy source computed over an operating season.

**SECTION N1104  
LIGHTING SYSTEMS**

**N1104.1 Lighting equipment.** A minimum of 75 percent of the *lamps* in permanently installed lighting fixtures shall be *high-efficacy lamps*.

**APPENDIX E-1: RESIDENTIAL REQUIREMENTS**

**Energy Efficiency Certificate (Section N1101.9)**

<b>ENERGY EFFICIENCY CERTIFICATE N1101.9</b>	
Builder, Permit Holder or Registered Design Professional Print Name: Signature:	
Property Address:	
Date:	
Insulation Rating - List the value covering largest area to all that apply	R-Value
Ceiling/roof:	R-
Wall:	R-
Floor:	R-
Closed Crawl Space Wall:	R-
Closed Crawl Space Floor:	R-
Slab:	R-
Basement Wall:	R-
Fenestration:	
U-Factor	R-
Solar Heat Gain Coefficient(SHGC)	R-
Building Air Leakage	
<input type="checkbox"/> Visually inspected according to N1102.4.2.1 OR	
<input type="checkbox"/> Building Air Leakage Test Results (Sec. N1102.4.2.2) ACH50 [Target: 5.0] or CFM50/SFSA [Target: 0.30]	R-
Name of Tester / Company:	
Date:	Phone:
Ducts:	
Insulation	R-
Total Duct Leakage Test Result (Sect. N1103.2.2) (CFM25 Total/100SF) [Target: 6]	R-
Name of Tester or Company:	
Date:	Phone:
Certificate to be displayed permanently	

**APPENDIX E-2  
INSULATION AND AIR SEALING DETAILS**

**APPENDIX E-2.1**

**N1102.2.1 Ceilings with attic spaces:** Exception for fully enclosed attic floor systems

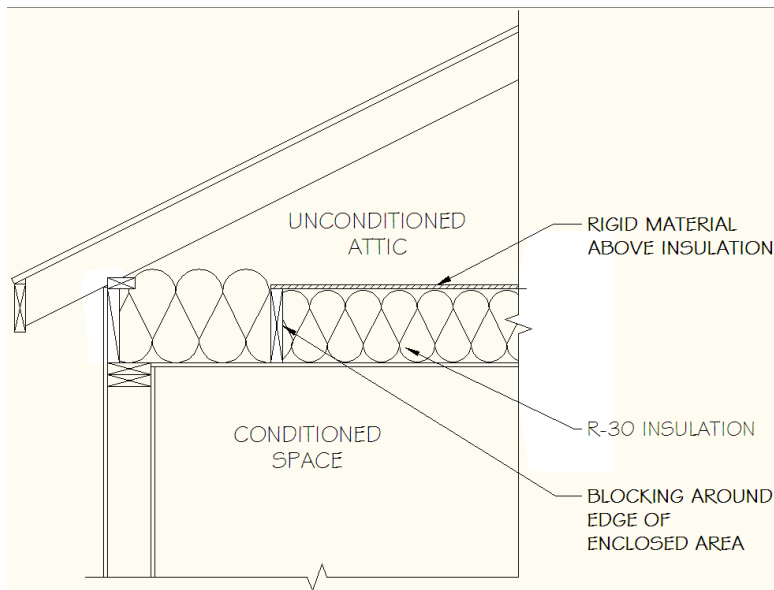

**SECTION VIEW OF CEILING WITH ATTIC SPACE**

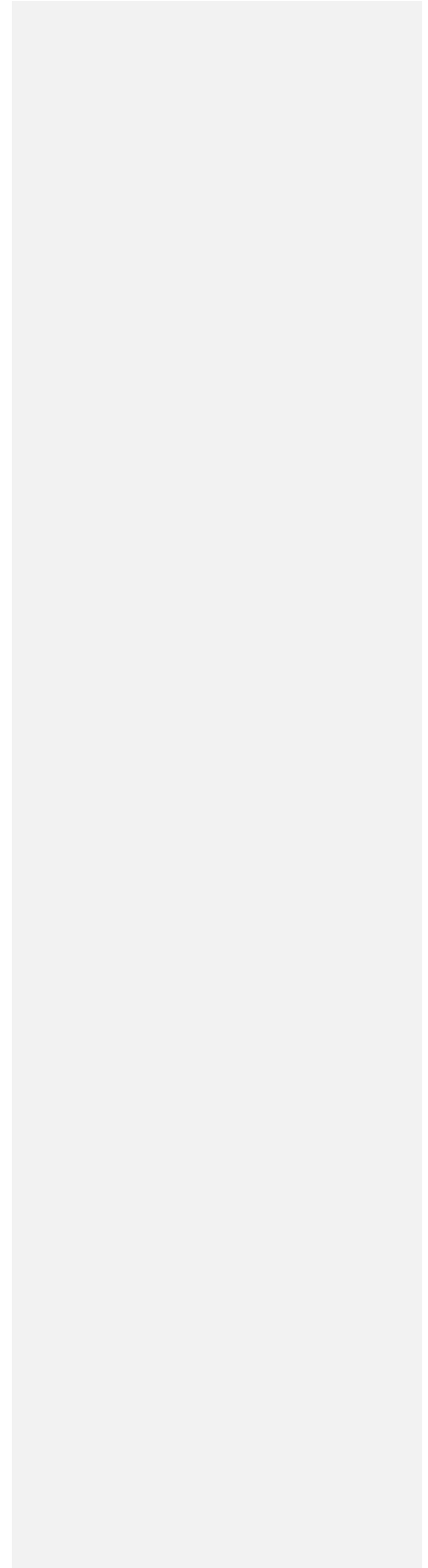

**APPENDIX E-2.2**

**N1102.2.9 Closed crawl space walls. Insulation illustrations**

Foam or porous insulation has 3" top inspection gap and extends down 3" above top of wall footing or concrete floor

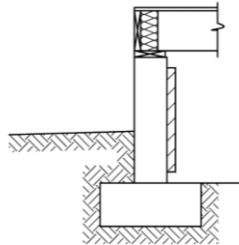

Foam or porous insulation has 3" top inspection gap and extends down 3" above interior ground surface

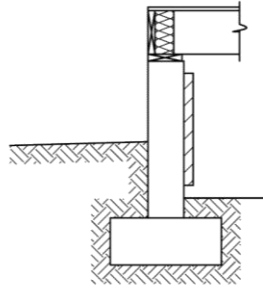

Foam or porous insulation has 3" top inspection gap and extends down 24" below grade

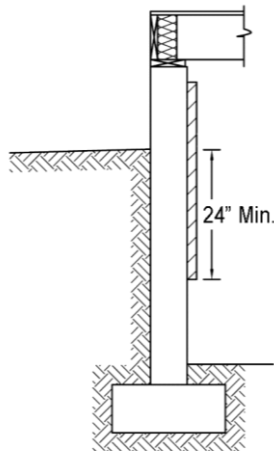

**APPENDIX E-2.3**

**N1102.2.12 Framed cavity walls. Insulation enclosure – 1. Tubs**

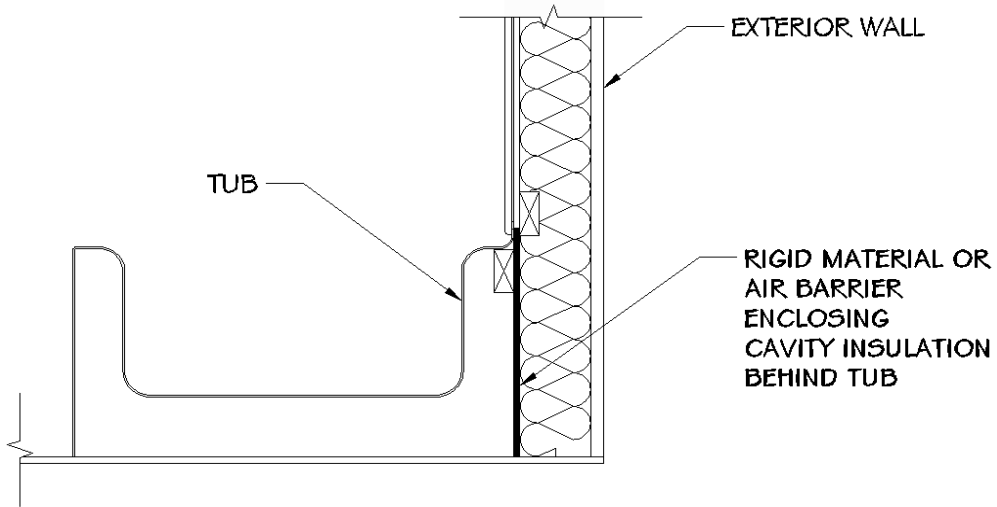

**SECTION VIEW OF BATH TUB ON EXTERIOR WALL**

**N1102.2.12 Framed cavity walls. Insulation enclosure – 2. Showers**

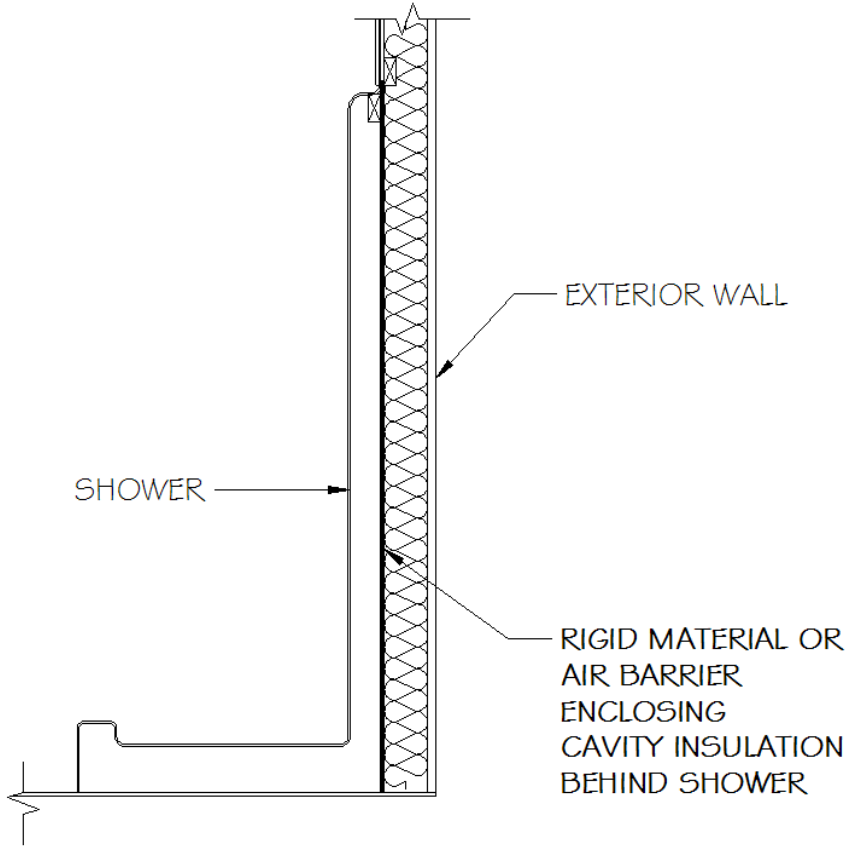

**SECTION VIEW OF SHOWER ON EXTERIOR WALL**

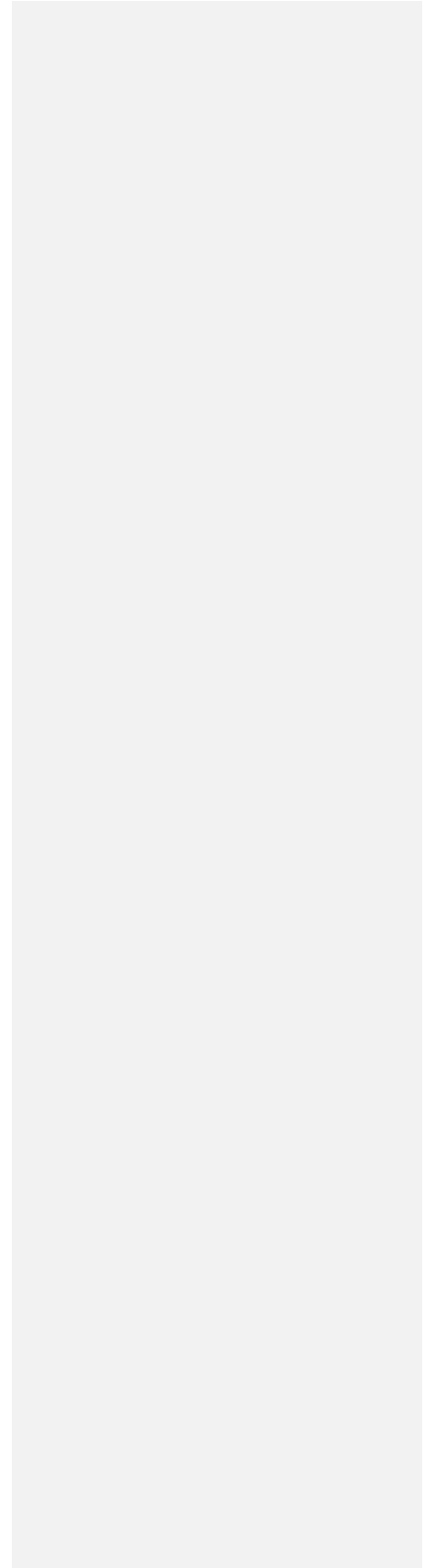

**N1102.2.12 Framed cavity walls. Insulation enclosure – 3. Stairs**

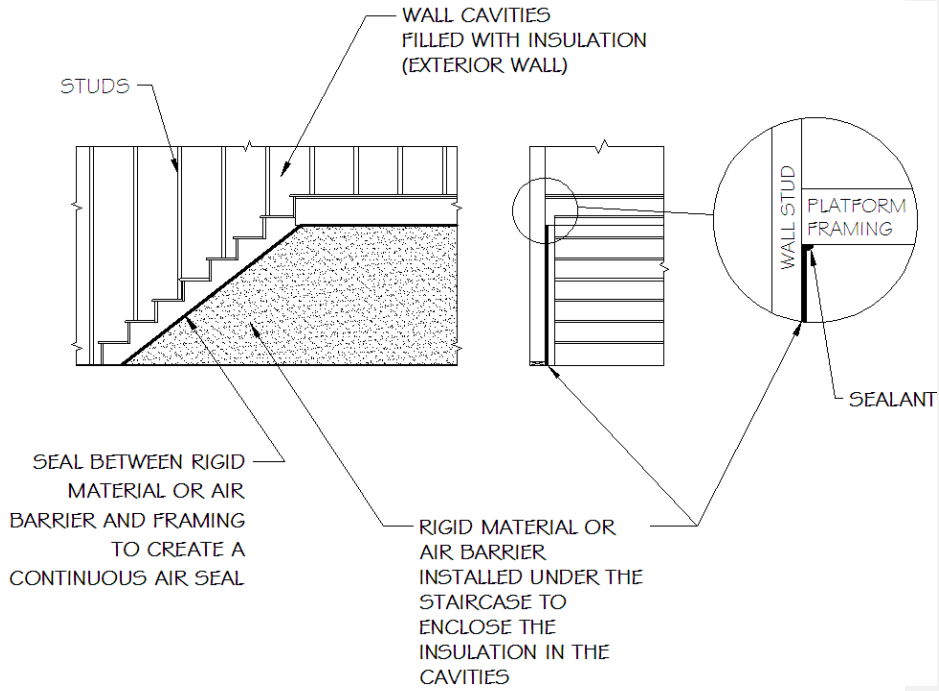

**SECTION VIEW OF INTERIOR STAIRCASE ON EXTERIOR WALL (OPTION 1)**

**N1102.2.12 Framed cavity walls. Insulation enclosure – 3. Stairs**

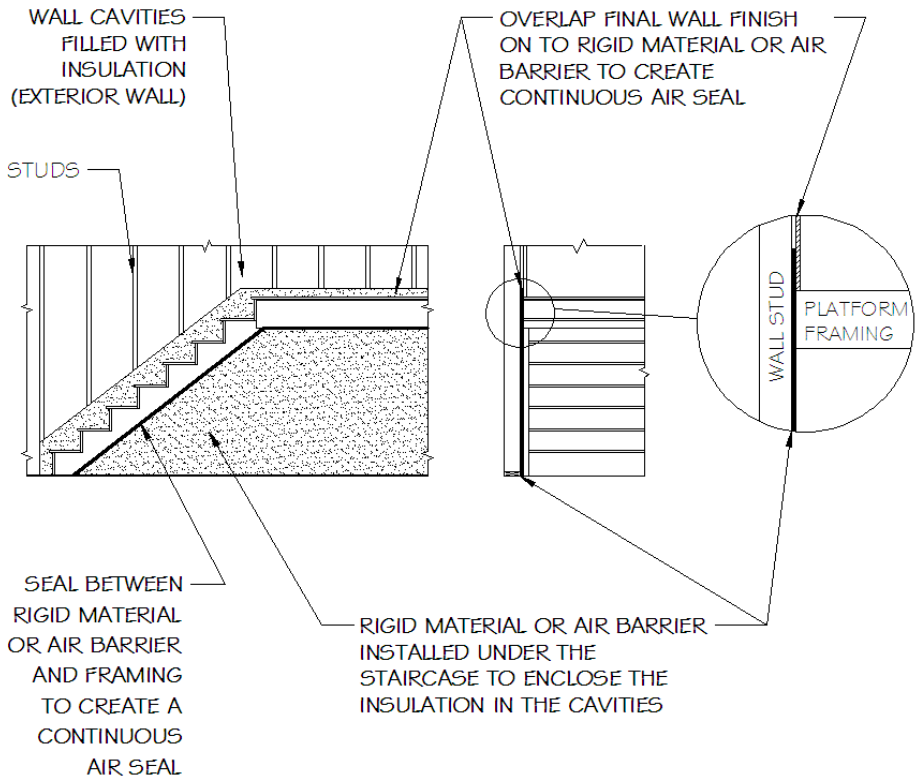

**SECTION VIEW OF INTERIOR STAIRCASE ON EXTERIOR WALL (OPTION 2)**



**N1102.2.12 Framed cavity wall. Insulation enclosure – 4. Direct vent gas fireplace**

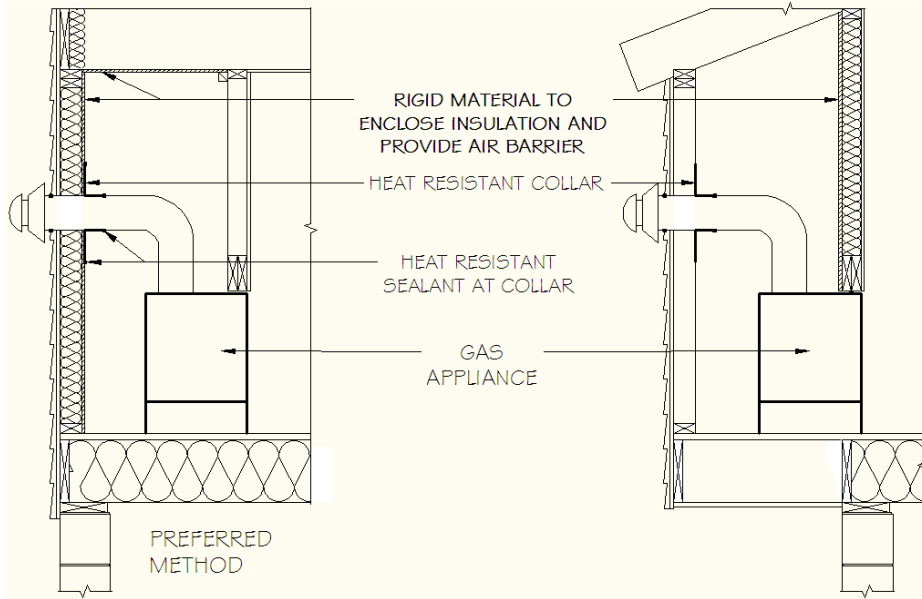

**SECTION VIEW OF DIRECT VENT GAS FIREPLACE**

**N1102.2.12 Framed cavity walls. Insulation enclosure – 5. Walls that adjoin attic spaces**

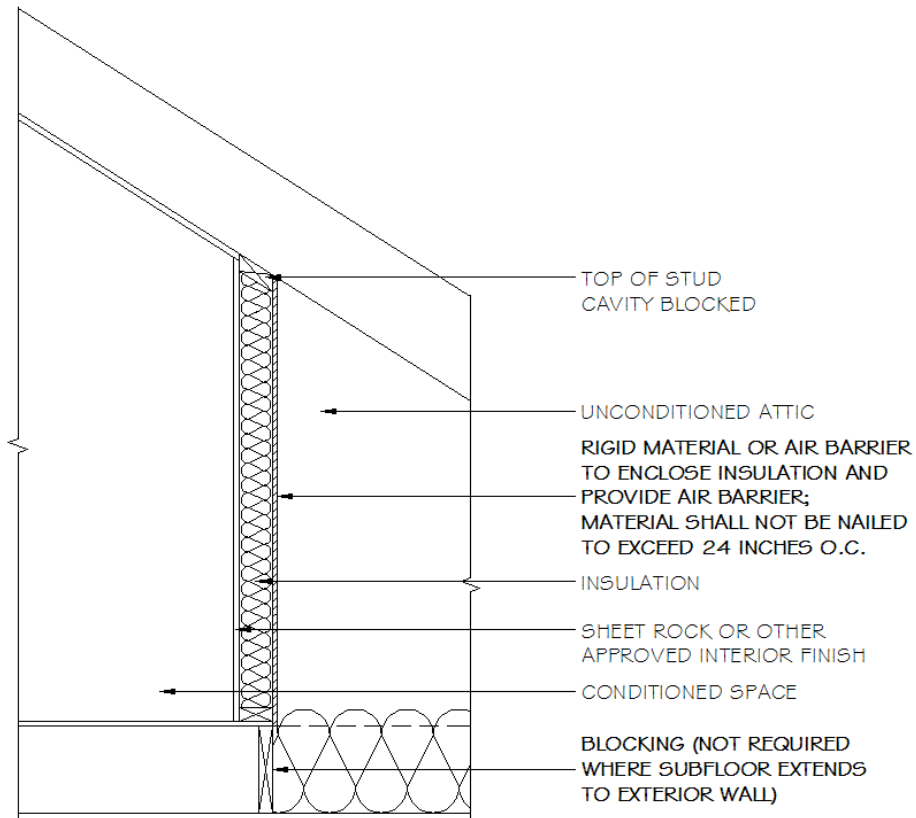

**SECTION VIEW OF WALL ADJOINING ATTIC SPACE**

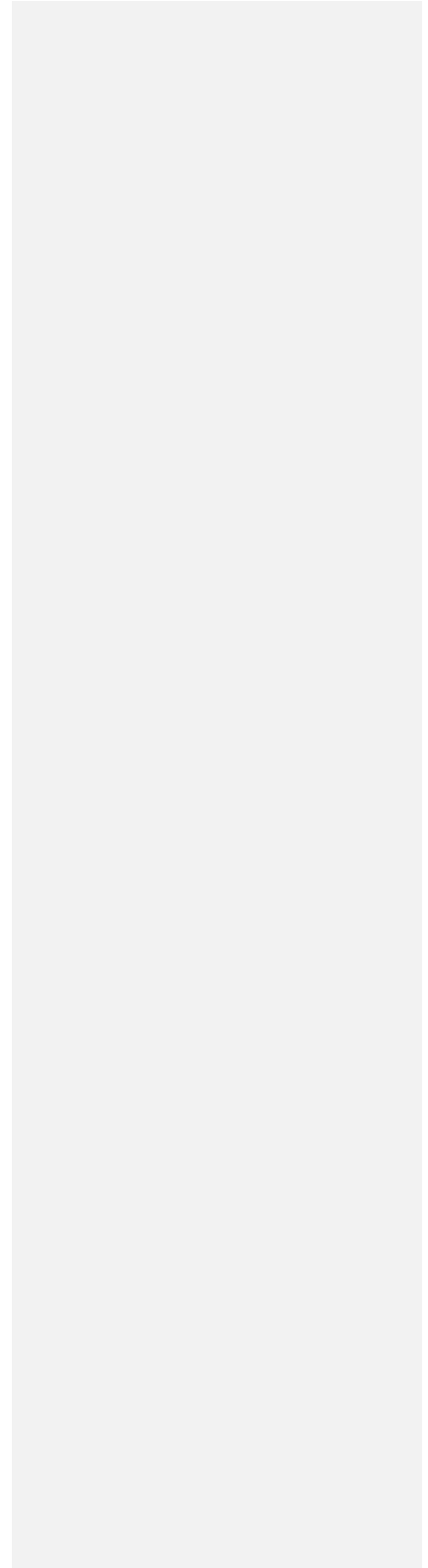

**N1102.2.12 Framed cavity walls. Insulation enclosure – 5. Walls that adjoin attic spaces**

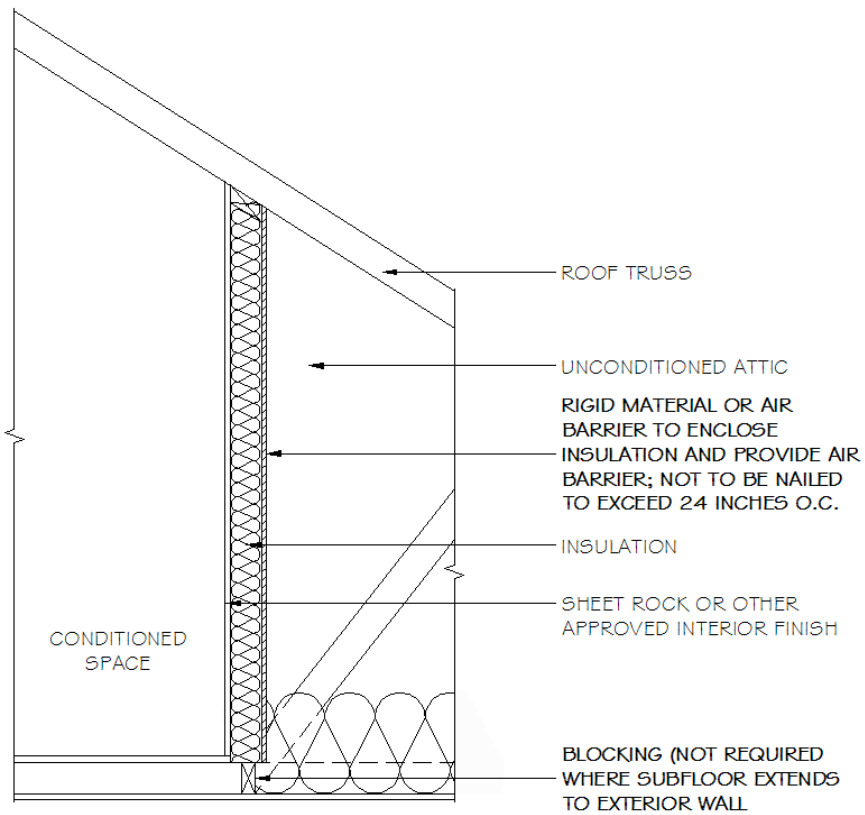

**SECTION VIEW OF WALL ADJOINING ATTIC SPACE**

**APPENDIX E-2.4**

**N1102.4.1 Building thermal envelope. – 1. Block and seal floor/ceiling systems**

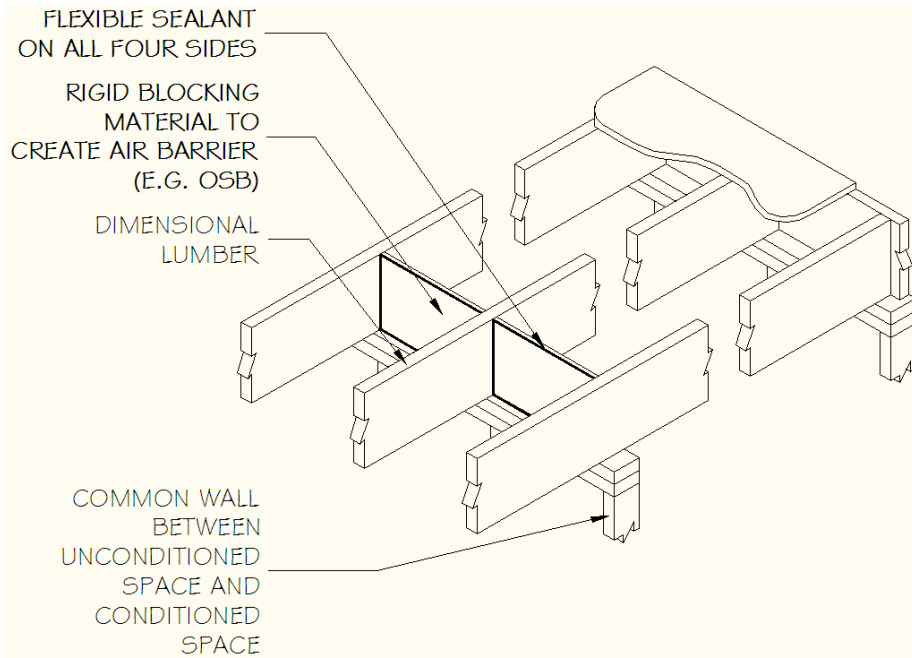

**ISOMETRIC VIEW OF DIMENSIONAL LUMBER FLOOR/CEILING SYSTEM ABOVE COMMON WALL BETWEEN UNCONDITIONED AND CONDITIONED SPACE**

**N1102.4.1 Building thermal envelope. – 1. Block and seal floor/ceiling systems**

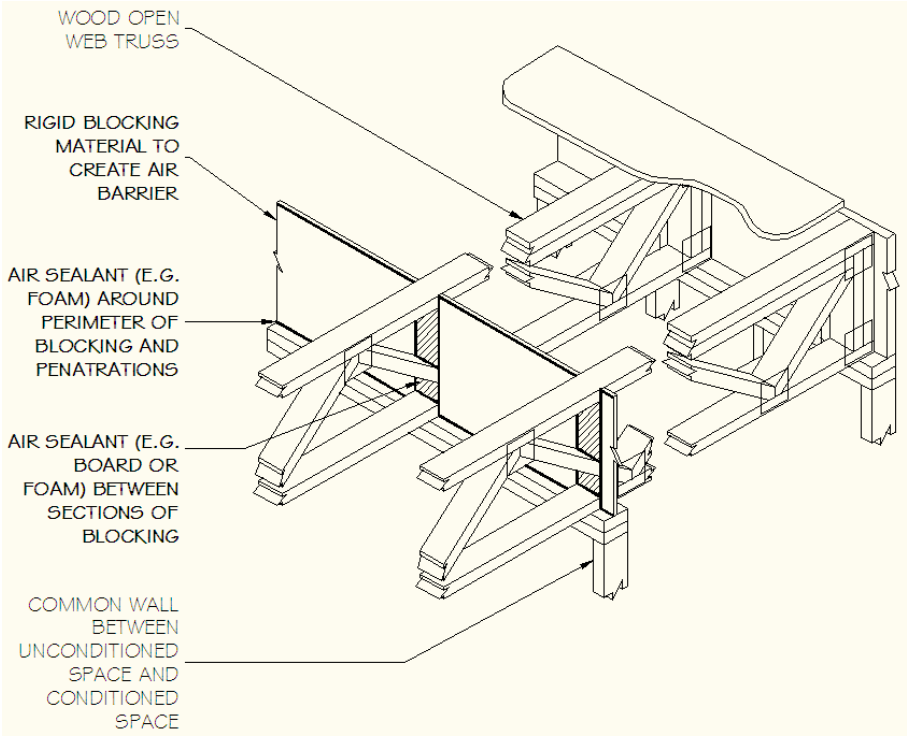

**ISOMETRIC VIEW OF WOOD TRUSS FLOOR/CEILING SYSTEM ABOVE COMMON WALL BETWEEN UNCONDITIONED AND CONDITIONED SPACE**

**N1102.4.1 Building thermal envelope. – 1. Block and seal floor/ceiling systems**

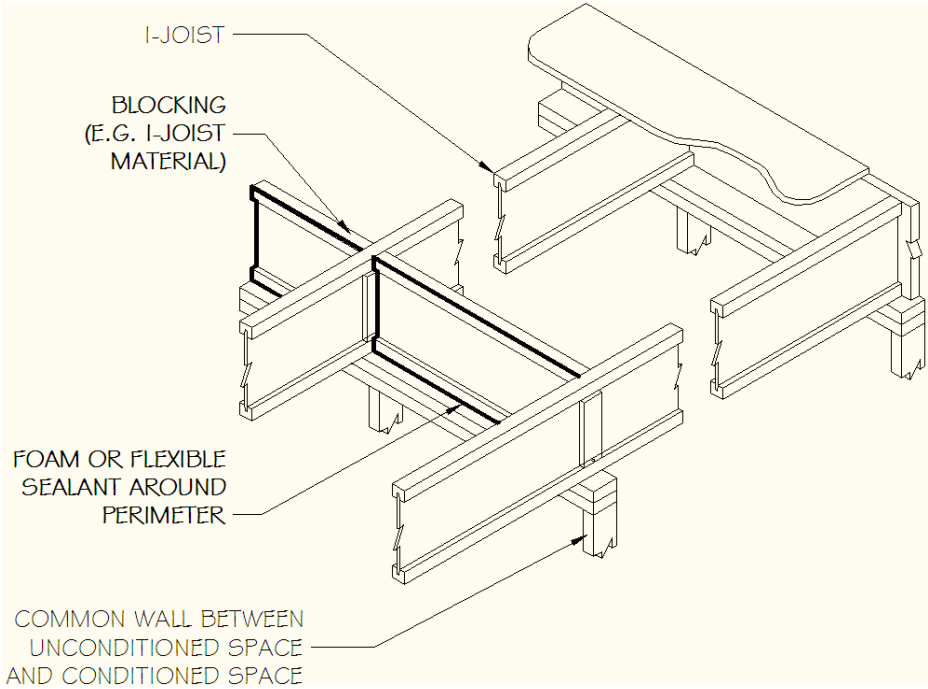

**ISOMETRIC VIEW OF I-JOIST FLOOR/CEILING SYSTEM ABOVE COMMON WALL BETWEEN UNCONDITIONED AND CONDITIONED SPACE**

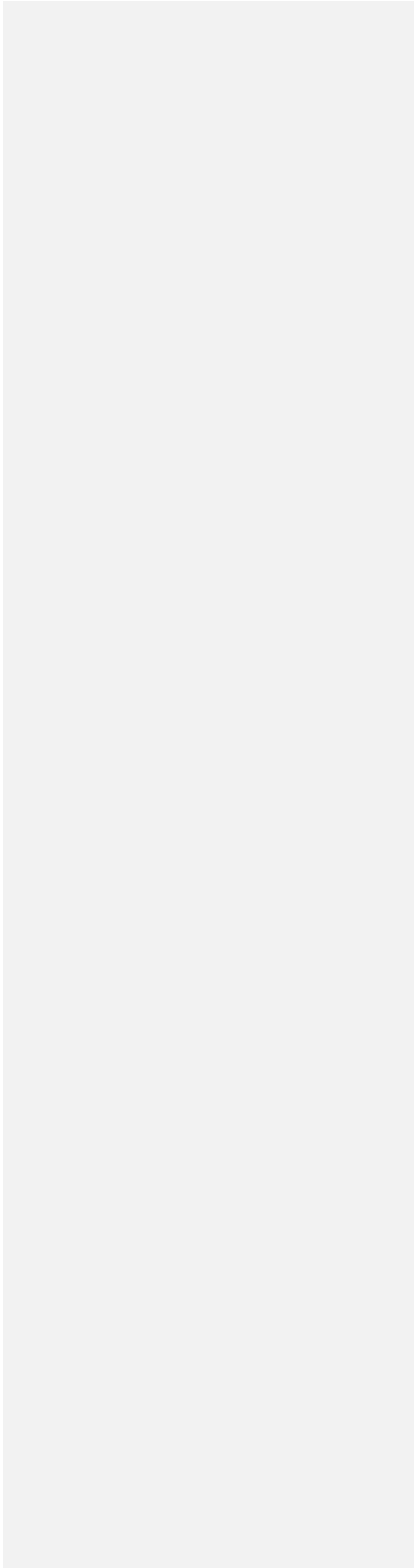

**N1102.4.1 Building thermal envelope – 2. Cap and seal shafts and chases**

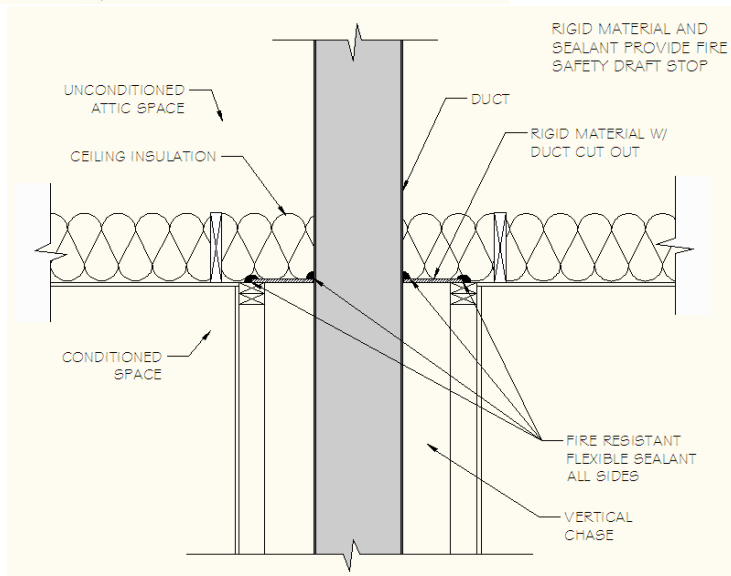
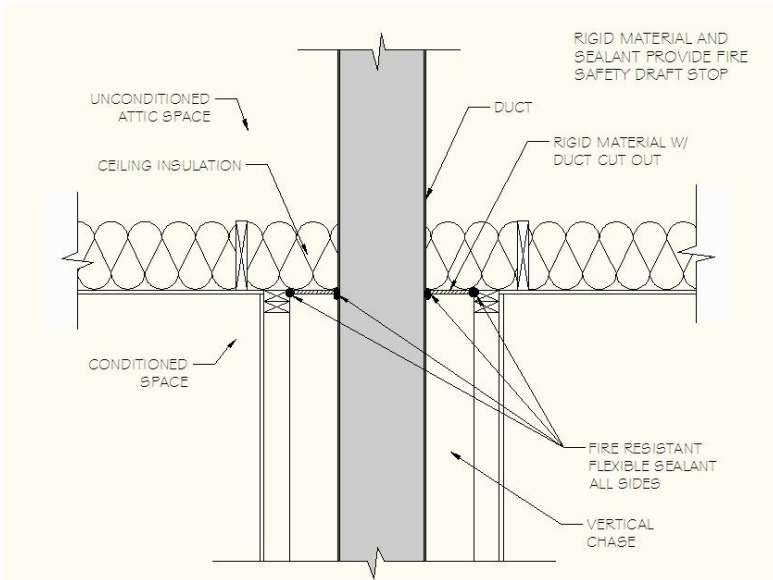

**SECTION VIEWS OF DUCT PENETRATING INTO ATTIC**

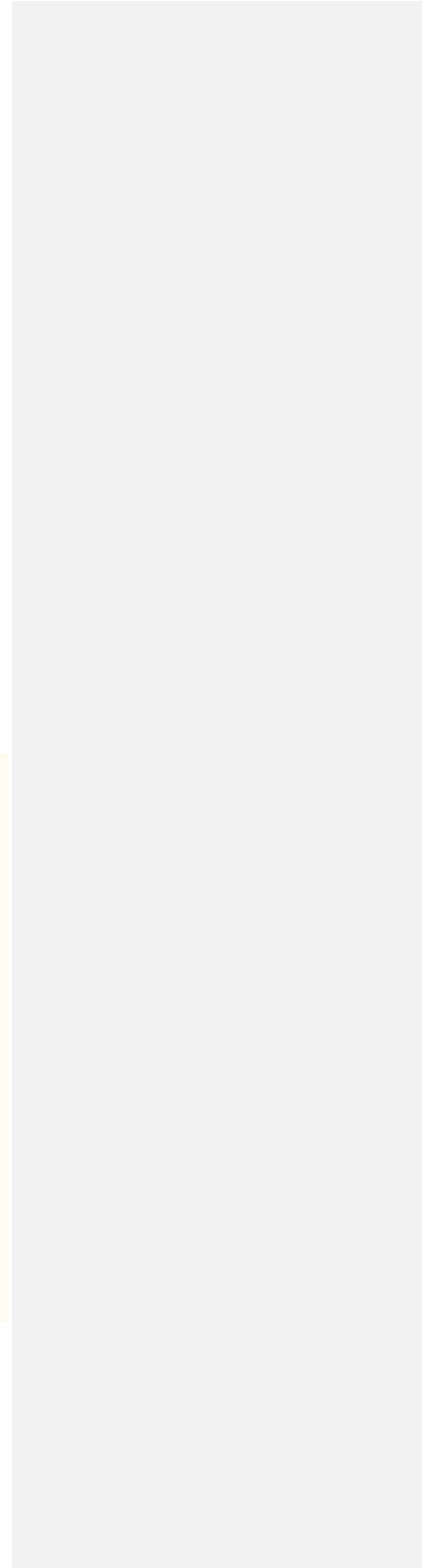

**N1102.4.1 Building thermal envelope. – 3. Cap and seal soffit or dropped ceiling**

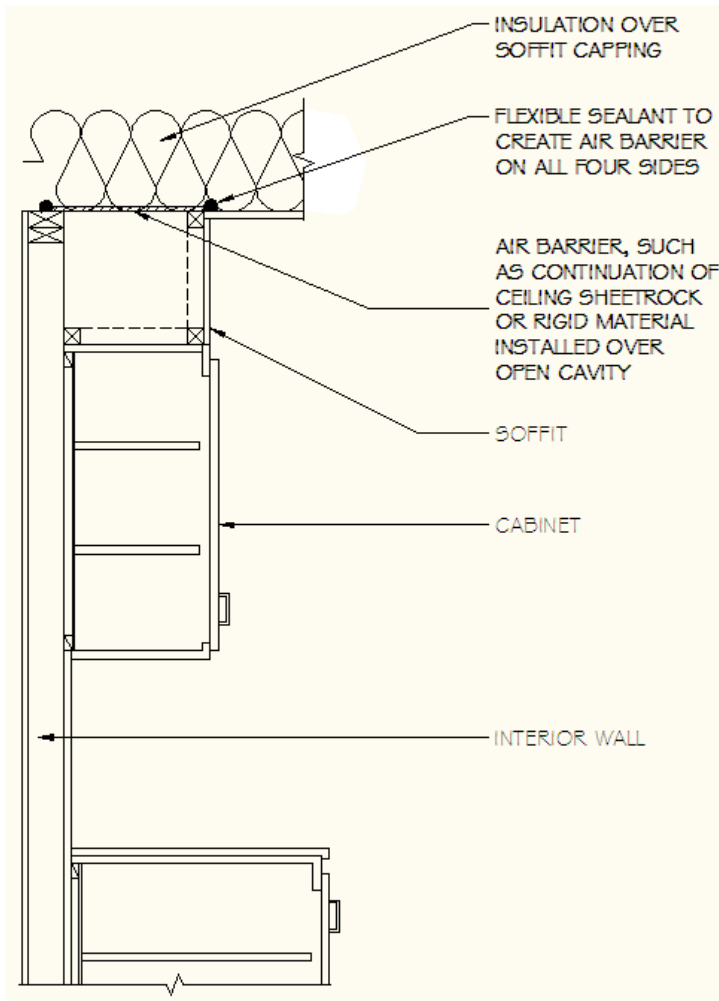

**SECTION VIEW OF SOFFIT OVER CABINET**

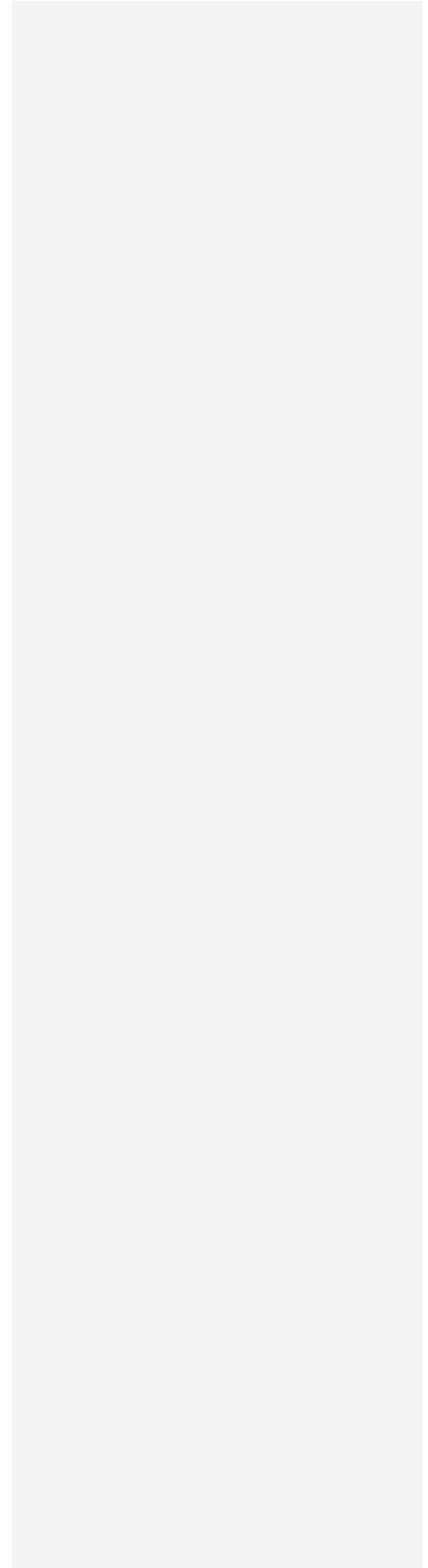



**N1102.4.1 Building thermal envelope. – 4. Seal HVAC boot penetration – floor**

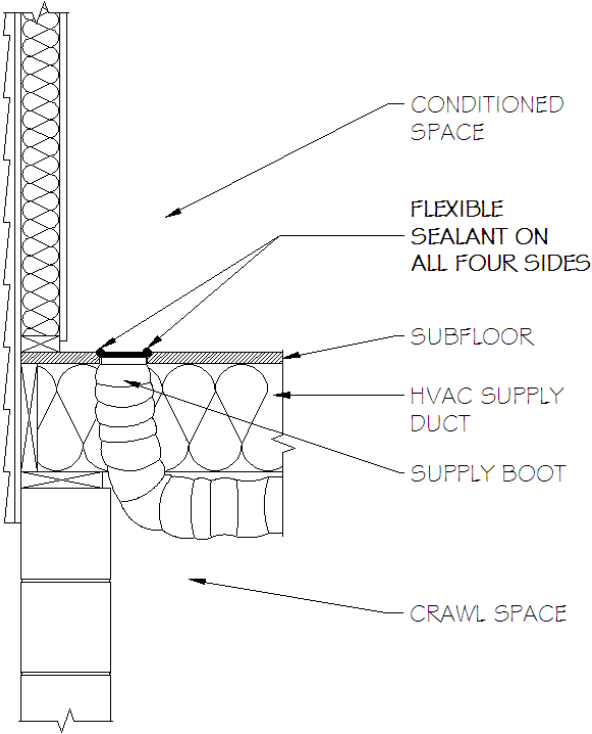

**SECTION VIEW OF FLOOR HVAC BOOT PENETRATION**

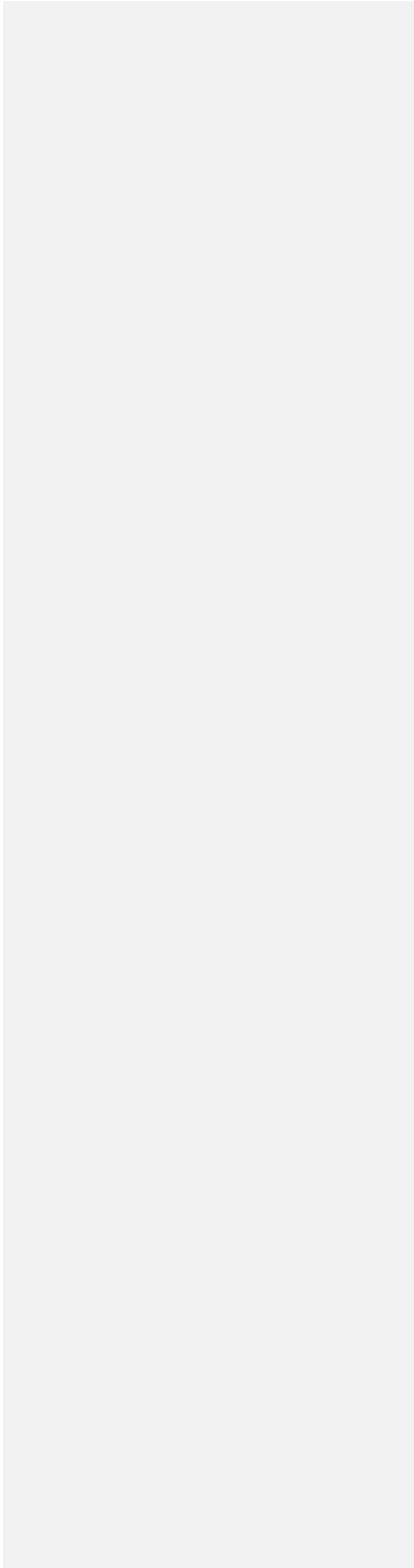

**N1102.4.1 Building thermal envelope. – 4. Seal HVAC boot penetration – ceiling**

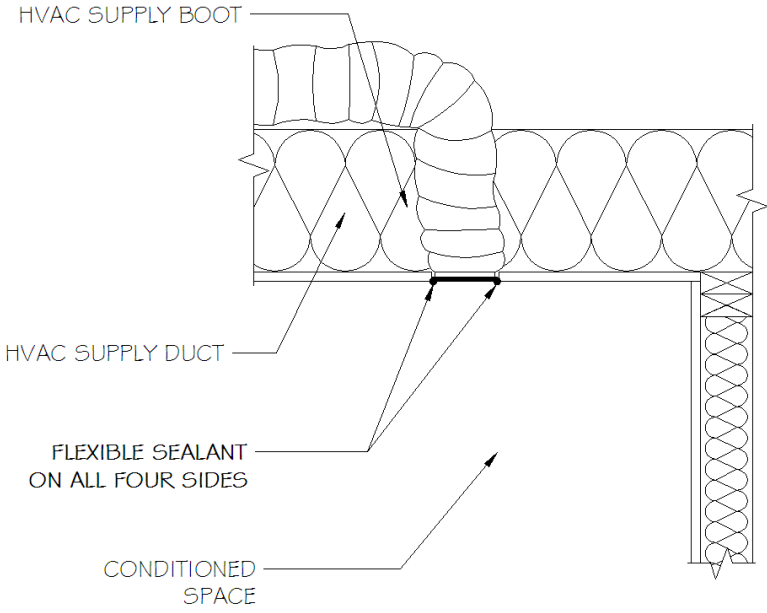

**SECTION VIEW OF CEILING HVAC BOOT PENETRATION**

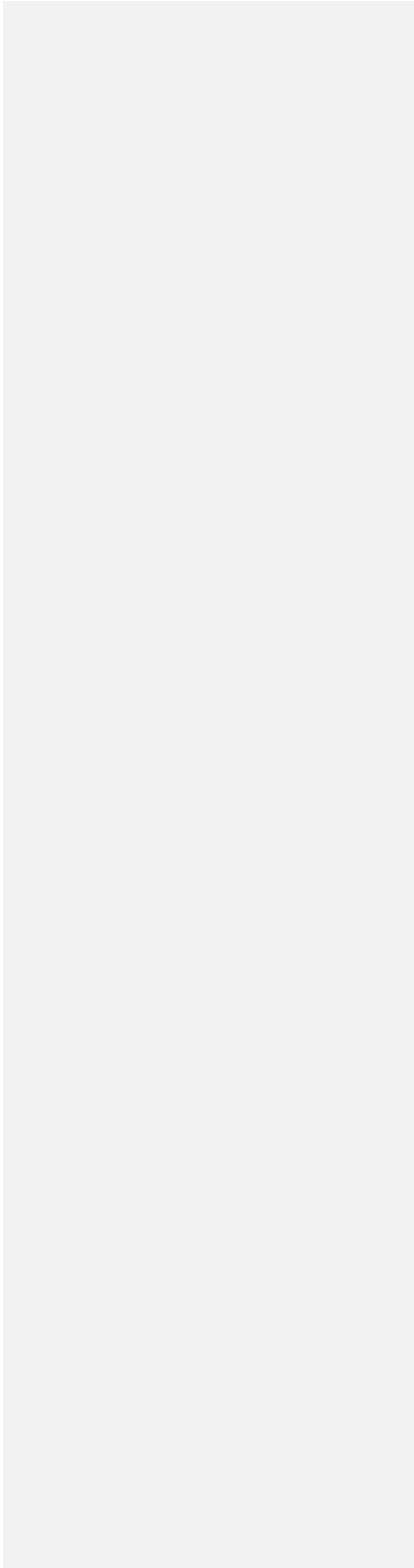

**APPENDIX E-3:  
SAMPLE WORKSHEETS FOR RESIDENTIAL AIR AND DUCT LEAKAGE TESTING  
APPENDIX E-3A: Air sealing: Visual inspection option (Section N1102.4.2.1)  
Sample Worksheet**

**N1102.4.2 Air sealing.** Building envelope air tightness shall be demonstrated by Section N1102.4.2.1 or N1102.4.2.2:

**N1102.4.2.1 Visual inspection option.** Building envelope tightness shall be considered acceptable when items providing insulation enclosure in N1102.2.12 and air sealing in N1102.4.1 are addressed and when the items listed in Table N1102.4.2, applicable to the method of construction, are certified by the by the builder, permit holder or registered design professional via the certificate in Appendix E-1.

**TABLE N1102.4.2  
AIR BARRIER INSPECTION**

COMPONENT	CRITERIA
Ceiling/attic	<p>Sealants or gaskets provide a continuous air barrier system joining the top plate of framed walls with either the ceiling drywall or the top edge of wall drywall to prevent air leakage.</p> <p>Top plate penetrations are sealed.</p> <p>For ceiling finishes that are not air barrier systems such as tongue-and-groove planks, air barrier systems,(for example, taped house wrap), shall be used above the finish</p> <p>Note: It is acceptable that sealants or gaskets applied as part of the application of the drywall will not be observable by the code official.</p>
Walls	Sill plate is gasketed or sealed to subfloor or slab.
Windows and doors	Space between window and exterior door jambs and framing is sealed.
Floors (including above-garage and cantilevered floors)	Air barrier system is installed at any exposed edge of insulation.
Penetrations	Utility penetrations through the building thermal envelope, including those for plumbing, electrical wiring, ductwork, security and fire alarm wiring, and control wiring, shall be sealed.
Garage separation	Air sealing is provided between the garage and conditioned spaces. An air barrier system shall be installed between the ceiling system above the garage and the ceiling system of interior spaces.
Duct boots	Sealing HVAC register boots and return boxes to subfloor or drywall.
Recessed lighting	Recessed light fixtures are air tight, IC rated, and sealed to drywall. <b>Exception</b> —fixtures not penetrating the building envelope.

**Property Address:**

**N1102.4.2.1 Visual Inspection Option**

The inspection information including tester name, date, and contact shall be included on the certificate described in Section N1101.9.

\_\_\_\_\_  
Signature

\_\_\_\_\_  
Date

**APPENDIX E-3B**  
**Air sealing: Testing option (Section N1102.4.2.2)**  
**Sample Worksheet**

**N1102.4.2 Air sealing.** Building envelope air tightness shall be demonstrated by Section N1102.4.2.1 or N1102.4.2.2:

**N1102.4.2.2 Testing option.** Building envelope tightness shall be considered acceptable when items providing insulation enclosure in N1102.2.12 and air sealing in N1102.4.1 are addressed and when tested air leakage is less than or equal to one of the two following performance measurements:

1. 0.304 CFM50/Square Foot of Surface Area (SFSA) or
2. Five (5) air changes per hour (ACH50)

When tested with a blower door fan assembly, at a pressure of 33.5 psf (50 Pa). A single point depressurization, not temperature corrected, test is sufficient to comply with this provision, provided that the blower door fan assembly has been certified by the manufacturer to be capable of conducting tests in accordance with ASTM E779-03. Testing shall occur after rough in and after installation of penetrations of the building envelope, including penetrations for utilities, plumbing, electrical, ventilation and combustion appliances. Testing shall be reported by the permit holder, a NC licensed general contractor, a NC licensed HVAC contractor, a NC licensed Home Inspector, a registered design professional, a *certified BPI Envelope Professional* or a *certified HERS rater*.

During testing:

1. Exterior windows and doors, fireplace and stove doors shall be closed, but not sealed;
2. Dampers shall be closed, but not sealed, including exhaust, backdraft, and flue dampers;
3. Interior doors shall be open;
4. Exterior openings for continuous ventilation systems, air intake ducted to the return side of the conditioning system, and energy or heat recovery ventilators shall be closed and sealed;
5. Heating and cooling system(s) shall be turned off; and
6. Supply and return registers shall not be sealed.

The air leakage information, including building air leakage result, tester name, date, and contact information, shall be included on the certificate described in Section N1101.9.

**For Test Criteria 1** above, the report shall be produced in the following manner: Perform the blower door test and record the *CFM50* \_\_\_\_\_. Calculate the total square feet of surface area for the building thermal envelope, all floors, ceilings, and walls (this includes windows and doors) and record the area \_\_\_\_\_. Divide *CFM50* by the total square feet and record the result below. If the result is less than or equal to **[0.30 CFM50/SFSA]** the envelope tightness is acceptable; or

**For Test Criteria 2** above, the report shall be produced in the following manner: Perform a blower door test and record the *CFM50* \_\_\_\_\_. Multiply the *CFM50* by 60 minutes to create *CFHour50* and record \_\_\_\_\_. Then calculate the total conditioned volume of the home and record \_\_\_\_\_. Divide the *CFHour50* by the total volume and record the result below. If the result is less than or equal to **[5 ACH50]** the envelope tightness is acceptable.

**Property Address:**

\_\_\_\_\_  
Company Name \_\_\_\_\_  
Contact Information : \_\_\_\_\_  
\_\_\_\_\_

\_\_\_\_\_  
Signature of Tester

\_\_\_\_\_  
Date

Permit Holder, NC Licensed General Contractor, NC Licensed HVAC Contractor,  
NC Licensed Home Inspector, Registered Design Professional,  
Certified BPI Envelope Professional, or Certified HERS Rater (**circle one**)

**APPENDIX E-3C**  
**Duct sealing, Duct air leakage test (Section N1103.2.2)**  
**Sample Worksheet**

**N1103.2.2 Sealing** All ducts, air handlers, filter boxes and building cavities used as ducts shall be sealed. Joints and seams shall comply with **Part V – Mechanical, Section 603.9 of the North Carolina Residential Code.**

Duct tightness shall be verified as follows:

Total duct leakage less than or equal to 6 CFM (18 L/min) per 100 ft<sup>2</sup> (9.29 m<sup>2</sup>) of *conditioned floor area* served by that system when tested at a pressure differential of 0.1 inches w.g. (25 Pa) across the entire system, including the manufacturer's air handler enclosure.

During testing:

1. Block, if present, the ventilation air duct connected to the conditioning system.
2. The duct air leakage testing equipment shall be attached to the largest return in the system or to the air handler.
3. The filter shall be removed and the air handler power shall be turned off.
4. Supply boots or registers and return boxes or grilles shall be taped, plugged, or otherwise sealed air tight.
5. The hose for measuring the 25 Pascals of pressure differential shall be inserted into the boot of the supply that is nominally closest to the air handler.
6. Specific instructions from the duct testing equipment manufacturer shall be followed to reach duct test pressure and measure duct air leakage.

Testing shall be performed and reported by the permit holder, a NC licensed general contractor, a NC licensed HVAC contractor, a NC licensed Home Inspector, a registered design professional, a certified BPI Envelope Professional or a certified HERS rater. A single point depressurization, not temperature corrected, test is sufficient to comply with this provision, provided that the duct testing fan assembly has been certified by the manufacturer to be capable of conducting tests in accordance with ASTM E1554-07.

The duct leakage information, including duct leakage result, tester name, date, company and contact information, shall be included on the certificate described in Section N1101.9.

For the Test Criteria, the report shall be produced in the following manner: perform the HVAC system air leakage test and record the CFM25. Calculate the total square feet of Conditioned Floor Area (CFA) served by that system. **Multiply CFM25 by 100, divide the result by the CFA and record the result.** If the result is less than or equal to [6 CFM25/100 SF] the HVAC system air tightness is acceptable.

**Complete one duct leakage report for each HVAC system serving the home:**

Property Address: \_\_\_\_\_

**HVAC System Number:** \_\_\_\_\_ Describe area of home served: \_\_\_\_\_

CFM25 Total \_\_\_\_\_ Conditioned Floor Area (CFA) served by system: \_\_\_\_\_ s.f.

**CFM25 x 100 divided by CFA = \_\_\_\_\_ CFM25/100SF (e.g. 100 CFM25x100/ 2,000 CFA = 5 CFM25/100SF)**

Fan attachment location \_\_\_\_\_

Company Name \_\_\_\_\_

Contact Information: \_\_\_\_\_

\_\_\_\_\_

\_\_\_\_\_  
Signature of Tester

\_\_\_\_\_  
Date

Permit Holder, NC Licensed General Contractor, NC Licensed HVAC Contractor,  
NC Licensed Home Inspector, Registered Design Professional,  
Certified BPI Envelope Professional, or Certified HERS Rater (**circle one**)

**APPENDIX E-4 ADDITIONAL VOLUNTARY CRITERIA FOR INCREASING ENERGY EFFICIENCY (High Efficiency Residential Option)**

1. **Introduction.** The increased energy efficiency measures identified in this appendix are strictly voluntary at the option of the permit holder and have been evaluated to be the most cost effective measures for achieving an additional 15-20% energy efficiency beyond the code minimums.
2. Requirements: Follow all sections of the Chapter 11 of the North Carolina Residential Energy Code, except the following.
  - a. Instead of using Table N1102.1 in Section N1102.1, use Table E-4A shown below.

**TABLE E-4A  
OPTIONAL INSULATION AND FENESTRATION REQUIREMENTS BY COMPONENT<sup>a</sup>**

CLIMATE ZONE	FENESTRATION U-FACTOR <sup>b</sup>	SKYLIGHT <sup>b</sup> U-FACTOR	GLAZED FENESTRATION SHGC <sup>b,e</sup>	CEILING R-VALUE <sup>k</sup>	WOOD FRAME WALL R-VALUE <sup>e</sup>	MASS WALL R-VALUE <sup>i</sup>	FLOOR R-VALUE	BASEMENT <sup>c</sup> WALL R-VALUE	SLAB <sup>h</sup> R-VALUE	CRAWL SPACE <sup>c</sup> WALL R-VALUE
3	0.32	0.65	0.25	38	19, 13+5, or 15+3 <sup>ch</sup>	5/10	19	10/13 <sup>r</sup>	5	10/13
4	0.32	0.60	0.25	38	19, 13+5, or 15+3 <sup>ch</sup>	5/10	19	10/13	10	10/13
5	0.32	0.60	(NR)	38	19, 13+5, or 15+3 <sup>ch</sup>	13/17	30 <sup>g</sup>	10/13	10	15/19

For SI: 1 foot = 304.8 mm.

- a. R-values are minimums. U-factors and SHGC are maximums.
- b. The fenestration U-factor column excludes skylights. The SHGC column applies to all glazed fenestration.
- c. "10/13" means R-10 continuous insulated sheathing on the interior or exterior of the home or R-13 cavity insulation at the interior of the basement wall or crawl space wall.
- d. For monolithic slabs, insulation shall be applied from the inspection gap downward to the bottom of the footing **or a maximum of 18 inches below grade**. For floating slabs, insulation shall extend to the bottom of the foundation wall or 24 inches, whichever is less. (See Appendix O) R-5 shall be added to the required slab edge R-values for heated slabs.
- e.- R-19 fiberglass batts compressed and installed in a nominal 2 x 6 framing cavity is deemed to comply. Fiberglass batts rated R-19 or higher compressed and installed in a 2x4 wall is not deemed to comply.
- f. Basement wall insulation is not required in warm-humid locations as defined by Figure N1101.2(1 and 2) and Table N1101.2.
- g. Or insulation sufficient to fill the framing cavity, R-19 minimum.
- h. "13+5" means R-13 cavity insulation plus R-5 insulated sheathing. 15+3 means R-15 cavity insulation plus R-3 insulated sheathing. If structural sheathing covers 25 percent or less of the exterior, insulating sheathing is not required where structural sheathing is used. If structural sheathing covers more than 25 percent of exterior, structural sheathing shall be supplemented with insulated sheathing of at least R-2. 13+2.5 means R-13 cavity insulation plus R-2.5 sheathing.
- i. For Mass Walls, the second R-value applies when more than half the insulation is on the interior of the mass wall.
- j. **R-30 shall be deemed to satisfy the ceiling insulation requirement wherever the full height of uncompressed R-30 insulation extends over the wall top plate at the eaves. Otherwise R-38 insulation is required where adequate clearance exists or insulation must extend to either the insulation baffle or within 1" of the attic roof deck.**
- k. Table value required except for roof edge where the space is limited by the pitch of the roof, there the insulation must fill the space up to the air baffle.

- b. Instead of using Table N1102.2 in Section N1102.2, use Table E-4B to find the maximum U-factors for building components.

**3. TABLE E-4B  
4. EQUIVALENT U-FACTORS<sup>a</sup>**

CLIMATE ZONE	FENESTRATION U-FACTOR	SKYLIGHT U-FACTOR	CEILING U-FACTOR	FRAME WALL U-FACTOR	MASS WALL U-FACTOR <sup>b</sup>	FLOOR U-FACTOR	BASEMENT WALL U-FACTOR <sup>d</sup>	CRAWL SPACE WALL U-FACTOR <sup>c</sup>
3	0.32	0.65	0.030	0.067	0.141	0.047	0.059	0.065
4	0.32	0.60	0.030	0.067	0.141	0.047	0.059	0.065
5	0.32	0.60	0.030	0.067	0.082	0.033	0.059	0.046

- a. Nonfenestration U-factors shall be obtained from measurement, calculation or an approved source.
- b. When more than half the insulation is on the interior, the mass wall U-factors shall be a maximum 0.12 in Zone 3, 0.10 in Zone 4, and the same as the frame wall U-factor in Zone 5.
- c. Basement wall U-factor of 0.360 in warm-humid locations as defined by Figures N1101.2(1), N1101.2(2) and Table N1101.2.

d. Foundation U-factor requirements shown in **Table E-4B** include wall construction and interior air films but exclude soil conductivity and exterior air films. U-factors for determining code compliance in accordance with Section N1102.1.3 (total UA alternative) shall be modified to include soil conductivity and exterior air films.

- c. Instead of using the air leakage value for maximum leakage shown in Section N1102.4.2.2, use the following:
  - i. **0.24** CFM50/Square Foot of Surface Area (SFSA) or
  - ii. **Four** (4) air changes per hour (ACH50)
- d. Instead of using the duct leakage value for maximum leakage shown in Section N1103.2.2 use the following:
  - Total duct leakage less than or equal to 4 CFM (12 L/min) per 100 ft<sup>2</sup> (9.29 m<sup>2</sup>) of conditioned floor area served by that system when tested at a pressure differential of 0.1 inches w.g. (25 Pa) across

**Table E-4C: Sample Confirmation Form for ADDITIONAL VOLUNTARY CRITERIA FOR INCREASING ENERGY EFFICIENCY (High Efficiency Residential Option)**

Insulation and Fenestration Values				Proposed Project Values
Climate Zone	3	4	5	
Fenestration U-Factor	0.32 <sup>j</sup>	0.32 <sup>j</sup>	0.32 <sup>j</sup>	
Skylight U-Factor	0.65	0.6	0.6	
Glazed Fenestration SHGC <sup>h, e</sup>	0.25	0.25	(NR)	
Ceiling R-value	38	38	38	
Wood Frame Wall R-value <sup>c</sup>	19, 13+5, or 15+3 <sup>th</sup>	19, 13+5, or 15+3 <sup>th</sup>	19, 13+5, or 15+3 <sup>th</sup>	
Mass Wall R-value <sup>j</sup>	5/10	5/10	13/17	
Floor R-value	19	19	30 <sup>g</sup>	
Basement Wall R-value <sup>c</sup>	10/13 <sup>f</sup>	10/13 <sup>f</sup>	10/13 <sup>f</sup>	
Slab R-value and Depth <sup>d</sup>	5, 2 ft	10, 2 ft	10, 2 ft	
Crawl Space Wall R-value <sup>c</sup>	10/13	10/13	15/19	
<b>Building Air Leakage</b>				
Visually inspected according to N1102.4.2.1 (check box) OR				
Building Air Leakage Test according to N1102.4.2.2 (check box). Show test value:				
ACH50 [Target: 4.0], or				
CFM50/SFSA [Target: 0.24]				
Name of Tester / Company:				
Date:				
<b>Duct Insulation and Sealing</b>				
Insulation Value	R-			
Duct Leakage Test Result (Sect. N1103.2.2)				
(CFM25 Total/100SF) [Target:4]				
Name of Tester or Company:				
Date:				

**E-4D: SAMPLE WORKSHEETS FOR RESIDENTIAL AIR AND DUCT LEAKAGE TESTING**

**E-4D.1**

**Air sealing: Visual inspection option (Section 402.4.2.1)**

**Sample Worksheet for Alternative Residential Energy Code for Higher Efficiency**

**402.4.2 Air sealing.** Building envelope air tightness shall be demonstrated by Section 402.4.2.1 or 402.4.2.2:

**402.4.2.1 Visual inspection option.** Building envelope tightness shall be considered acceptable when items providing insulation enclosure in 402.2.12 and air sealing in 402.4.1 are addressed and when the items listed in Table 402.4.2, applicable to the method of construction, are certified by the by the builder, permit holder or registered design professional via the certificate in Appendix 1.

**TABLE 402.4.2  
AIR BARRIER INSPECTION**

COMPONENT	CRITERIA
Ceiling/attic	Sealants or gaskets provide a continuous air barrier system joining the top plate of framed walls with either the ceiling drywall or the top edge of wall drywall to prevent air leakage. Top plate penetrations are sealed.  For ceiling finishes that are not air barrier systems such as tongue-and-groove planks, air barrier systems,(for example, taped house wrap), shall be used above the finish  Note: It is acceptable that sealants or gaskets applied as part of the application of the drywall will not be observable by the code official
Walls	Sill plate is gasketed or sealed to subfloor or slab.
Windows and doors	Space between window and exterior door jambs and framing is sealed.
Floors (including above-garage and cantilevered floors)	Air barrier system is installed at any exposed edge of insulation.
Penetrations	Utility penetrations through the building thermal envelope, including those for plumbing, electrical wiring, ductwork, security and fire alarm wiring, and control wiring, shall be sealed.
Garage separation	Air sealing is provided between the garage and conditioned spaces. An air barrier system shall be installed between the ceiling system above the garage and the ceiling system of interior spaces.
Duct boots	Sealing HVAC register boots and return boxes to subfloor or drywall.
Recessed lighting	Recessed light fixtures are air tight, IC rated, and sealed to drywall. <b>Exception</b> —fixtures not penetrating the building envelope.

**Property Address:**

\_\_\_\_\_

**402.4.2.1 Visual Inspection Option**

The inspection information including tester name, date, and contact shall be included on the certificate described in Section 401.3.

Signature \_\_\_\_\_

Date \_\_\_\_\_



**E-4D.2**

**Air sealing: Testing option (Section 402.4.2.2)**

**Sample Worksheet for Alternative Residential Energy Code for Higher Efficiency**

**402.4.2 Air sealing.** Building envelope air tightness shall be demonstrated by Section 402.4.2.1 or 402.4.2.2:

**402.4.2.2 Testing option.** Building envelope tightness shall be considered acceptable when items providing insulation enclosure in 402.2.12 and air sealing in 402.4.1 are addressed and when tested air leakage is less than or equal to one of the two following performance measurements:

- 1. 0.24 CFM50/Square Foot of Surface Area (SFSA) or
- 2. Four (4) air changes per hour (ACH50)

When tested with a blower door fan assembly, at a pressure of 33.5 psf (50 Pa). A single point depressurization, not temperature corrected, test is sufficient to comply with this provision, provided that the blower door fan assembly has been certified by the manufacturer to be capable of conducting tests in accordance with ASTM E779-03.

Testing shall occur after rough in and after installation of penetrations of the building envelope, including penetrations for utilities, plumbing, electrical, ventilation and combustion appliances. Testing shall be reported by the permit holder, a NC licensed general contractor, a NC licensed HVAC contractor, a NC licensed Home Inspector, a registered design professional, a *certified BPI Envelope Professional* or a *certified HERS rater*.

During testing:

- 1. Exterior windows and doors, fireplace and stove doors shall be closed, but not sealed;
- 2. Dampers shall be closed, but not sealed, including exhaust, backdraft, and flue dampers;
- 3. Interior doors shall be open;
- 4. Exterior openings for continuous ventilation systems, air intake ducted to the return side of the conditioning system, and energy or heat recovery ventilators shall be closed and sealed;
- 5. Heating and cooling system(s) shall be turned off; and
- 6. Supply and return registers shall not be sealed.

The air leakage information, including building air leakage result, tester name, date, and contact information, shall be included on the certificate described in Section 401.3.

**For Test Criteria 1** above, the report shall be produced in the following manner: Perform the blower door test and record the *CFM50* \_\_\_\_\_. Calculate the total square feet of surface area for the building thermal envelope, all floors, ceilings, and walls (this includes windows and doors) and record the area \_\_\_\_\_. Divide *CFM50* by the total square feet and record the result below. If the result is less than or equal to **[0.24 CFM50/SFSA]** the envelope tightness is acceptable; or

**For Test Criteria 2** above, the report shall be produced in the following manner: Perform a blower door test and record the *CFM50* \_\_\_\_\_. Multiply the *CFM50* by 60 minutes to create *CFHour50* and record \_\_\_\_\_. Then calculate the total conditioned volume of the home and record \_\_\_\_\_. Divide the *CFH50* by the total volume and record the result below. If the result is less than or equal to **[4 ACH50]** the envelope tightness is acceptable.

**Property Address:** \_\_\_\_\_

Company Name \_\_\_\_\_

Contact Information : \_\_\_\_\_

\_\_\_\_\_

Signature of Tester

Date

Permit Holder, NC Licensed General Contractor, NC Licensed HVAC Contractor,  
NC Licensed Home Inspector, Registered Design Professional,  
Certified BPI Envelope Professional, or Certified HERS Rater (**circle one**)

### E-4D.3

#### Duct sealing. Duct air leakage test (Section 403.2.2)

#### Sample Worksheet for Alternative Residential Energy Code for Higher Efficiency

**403.2.2 Sealing** All ducts, air handlers, filter boxes and building cavities used as ducts shall be sealed. Joints and seams shall comply with **Part V – Mechanical, Section 603.9 of the North Carolina Residential Code.**

Duct tightness shall be verified as follows:

Total duct leakage less than or equal to 4 CFM (12 L/min) per 100 ft<sup>2</sup> (9.29 m<sup>2</sup>) of *conditioned floor area* served by that system when tested at a pressure differential of 0.1 inches w.g. (25 Pa) across the entire system, including the manufacturer's air handler enclosure.

During testing:

1. Block, if present, the ventilation air duct connected to the conditioning system.
2. The duct air leakage testing equipment shall be attached to the largest return in the system or to the air handler.
3. The filter shall be removed and the air handler power shall be turned off.
3. Supply boots or registers and return boxes or grilles shall be taped, plugged, or otherwise sealed air tight.
4. The hose for measuring the 25 Pascals of pressure differential shall be inserted into the boot of the supply that is nominally closest to the air handler.
5. Specific instructions from the duct testing equipment manufacturer shall be followed to reach duct test pressure and measure duct air leakage.

Testing shall be performed and reported by the permit holder, a NC licensed general contractor, a NC licensed HVAC contractor, a NC licensed Home Inspector, a registered design professional, a certified BPI Envelope Professional or a certified HERS rater. A single point depressurization, not temperature corrected, test is sufficient to comply with this provision, provided that the duct testing fan assembly has been certified by the manufacturer to be capable of conducting tests in accordance with ASTM E1554-07.

The duct leakage information, including duct leakage result, tester name, date, company and contact information, shall be included on the certificate described in Section 401.3.

For the Test Criteria, the report shall be produced in the following manner: perform the HVAC system air leakage test and record the CFM25. **Calculate the total square feet of Conditioned Floor Area (CFA) served by that system. Multiply CFM25 by 100, divide the result by the CFA and record the result.** If the result is less than or equal to [4 CFM25/100 SF] the HVAC system air tightness is acceptable.

#### Complete one duct leakage report for each HVAC system serving the home:

Property Address: \_\_\_\_\_

**HVAC System Number:** \_\_\_\_\_ Describe area of home served: \_\_\_\_\_

CFM25 Total \_\_\_\_\_ Conditioned Floor Area (CFA) served by system: \_\_\_\_\_ s.f.

**CFM25 x 100 divided by CFA = \_\_\_\_\_ CFM25/100SF** (e.g. 70 CFM25x100/ 2,000 CFA = 3.5 CFM25/100SF)

Fan attachment location \_\_\_\_\_

Company Name \_\_\_\_\_

Contact Information: \_\_\_\_\_

\_\_\_\_\_

\_\_\_\_\_  
Signature of Tester

\_\_\_\_\_  
Date

Permit Holder, NC Licensed General Contractor, NC Licensed HVAC Contractor,  
NC Licensed Home Inspector, Registered Design Professional,  
Certified BPI Envelope Professional, or Certified HERS Rater (**circle one**)

**PART IX REFERENCED STANDARDS  
CHAPTER 43**

**REFERENCED STANDARDS**

<b>ASHRAE</b>	American Society of Heating, Refrigerating and Air-Conditioning Engineers, Inc. 1791 Tullie Circle, NE Atlanta, GA 30329-2305	
Standard reference number	Title	Referenced in code section number
ASHRAE—2005	ASHRAE Handbook of Fundamentals	N1102.1.3

<b>ASTM</b>	ASTM International 100 Barr Harbor Drive West Conshohocken, PA 19428-2859	
Standard reference number	Title	Referenced in code section number
E 283—04	Test Method for Determining the Rate of Air Leakage Through Exterior Windows, Curtain Walls and Doors Under Specified Pressure Differences Across the Specimen	N1102.4.5
E779-03	Standard Test Method for Determining Air Leakage Rate by Fan Pressurization	N1102.4.2.2
E2178-03	Standard Test Method for Air Permeance of Building Materials	R202
E1554-07	Standard Test Methods for Determining Air Leakage of Air Distribution Systems by Fan Pressurization	N1103.2.2

<b>CSA</b>	Canadian Standards Association 5060 Spectrum Way Mississauga, Ontario, Canada L4W 5N6	
Standard reference number	Title	Referenced in code section number
101/1.5.2/A440—08	Specifications for Windows, Doors and Unit Skylights,	N1102.4.4

<b>DOE</b>	U.S. Department of Energy c/o Superintendent of Documents U.S. Government Printing Office Washington, DC 20402-9325	
Standard reference number	Title	Referenced in code section number
NAECA - National Appliance Energy Conservation Act	Minimum energy efficiency standards for residential central air conditioners and heat pumps	N1103.6.2
Title 10, Volume 3; 10CFR430.32	ENERGY CONSERVATION PROGRAM FOR CONSUMER PRODUCTS. Subpart C: Energy and Water Conservation Standards	N1103.6.2

<b>ICC</b>	International Code Council, Inc. 500 New Jersey Avenue, NW 6th Floor Washington, DC 20001	
Standard reference number	Title	Referenced in code section number
IRC—09	International Residential Code	N1102.2.3, N1103.6

<b><u>US—FTC</u></b>	United States - Federal Trade Commission 600 Pennsylvania Avenue NW Washington, DC 20580	
<u>Standard reference number</u>	<u>Title</u>	<u>Referenced in code section number</u>
CFR Title 16	R-value Rule	N1101.6