

## **2018 NC State Residential Code Amendments**

**(adopted December 2017 through June 2022)**

**(Note: includes identified NC Errata)**

The North Carolina Codes are available at <https://codes.iccsafe.org/codes/north-carolina> for purchase online or free "view only". Bound hard copies are available for walk-in purchase only at the following location.

NC Department of Insurance, 325 North Salisbury Street, Raleigh, NC 27603  
919-647-0061 (call for availability)

The following pages represent a summary of the Building Code Council adopted amendments that have been approved by the Rules Review Commission.

2018 NC Residential Code (based on the 2015 International Residential Code) effective 1/1/2019

These amendments revise, delete or add to the adopted NC Residential Code.

2018 NC Residential Code  
R101.2.2 Accessory structures. (200901 Item B-19)

**R101.2.2 Accessory structures.**

Only the following *accessory structures* shall meet the provisions of this code.

1. Decks, see Appendix M,
2. Gazebos,
3. Retaining walls, see Section R404.4,
4. Detached masonry chimneys located less than 10 feet (3048 mm) from other buildings or lot lines,
5. Swimming pools and spas, see Appendix V,
6. Detached carports,  
**Exception:** Portable lightweight carports not exceeding 400 square feet (37 m<sup>2</sup>) or 12 foot (3658 mm) mean roof height.
7. *Docks, piers, bulkheads,* and waterway structures, see Section R327.

The delayed effective date of this Rule is January 1, 2022.  
The Statutory authority for Rule-making is G. S. 143-136; 143-138.

2018 NC Residential Code  
R102.5 Appendices. (191210 Item B-4)

**R102.5 Appendices.** Provisions in the appendices shall not apply unless specifically referenced in the code text ~~adopting ordinance~~.

The delayed effective date of this Rule is January 1, 2021.  
The Statutory authority for Rule-making is G. S. 143-136; 143-138.

June 14, 2022

2018 NC Residential Code  
R202 Definitions. (200901 Item B-19)

**ACCESSORY BUILDING.** ~~In one and two family dwellings not more than three stories above grade plane in height with a separate means of egress, a~~ A building that does not contain a sleeping room, the use of which is incidental accessory to that of the main building dwelling, and that is detached and located on the same lot as the dwelling. ~~An accessory building and is roofed over and with more than 50 percent of its exterior walls are enclosed. Examples of accessory buildings are garages, storage buildings, workshops, boat houses, treehouses, and similar structures.~~

**ACCESSORY STRUCTURE.** A structure that is accessory to the dwelling and not defined as an *accessory building*. Examples of accessory structures are fencing, decks, gazebos, arbors, retaining walls, barbecue pits, detached chimneys, playground equipment, yard art, *docks, piers*, etc.

The delayed effective date of this Rule is January 1, 2022.  
The Statutory authority for Rule-making is G. S. 143-136; 143-138.

2018 NC Residential Code  
R202 Definitions. (200901 Item B-7)

**AIR-IMPERMEABLE INSULATION.** An insulation having an air permanence equal to or less than 0.02 L/s-m<sup>2</sup> at 75 Pa pressure differential ~~as tested in accordance with~~ according to ASTM E2178 or E283 at the thickness applied.

The delayed effective date of this Rule is January 1, 2022.  
The Statutory authority for Rule-making is G. S. 143-136; 143-138.

2018 NC Residential Code  
R302.2 R313.1 & R202 Townhouses. (210608 Item B-7)

**[RB] DWELLING.** Any building that contains one or two *dwelling units (duplex)* on the same parcel of land, used, intended, or designed to be built, used, rented, leased, let or hired out to be occupied, or that are occupied for living purposes.

**[RB] DWELLING UNIT.** A single unit providing complete independent living facilities for a single family ~~one or more persons~~, including permanent provisions for living, sleeping, eating, cooking and sanitation.

The delayed effective date of this Rule is January 1, 2023.  
The Statutory authority for Rule-making is G. S. 143-136; 143-138.

June 14, 2022

2018 NC Residential Code  
R202, R305, R310, R328 Lofts. (180612 Item B-12)

**EGRESS ROOF ACCESS WINDOW.** A skylight or roof window designed and installed to satisfy the emergency escape and rescue opening requirements in Section R310.2.

The delayed effective date of this Rule is January 1, 2020.  
The Statutory authority for Rule-making is G. S. 143-136; 143-138.

2018 NC Residential Code  
Section 202 Definitions. (200310 Item B-7)

**FAMILY.** Family is an individual, two or more persons related by blood, marriage or law, or a group of not more than any ~~five~~ eight persons living together in a *dwelling unit*. Servants having common housekeeping facilities with a family consisting of an individual, or more persons related by blood, marriage or law, are a part of the family for this code.

The delayed effective date of this Rule is January 1, 2021.  
The Statutory authority for Rule-making is G. S. 143-136; 143-138.

2018 NC Residential Code  
R202 DEFINITIONS. (170613 Item B-10)

**FARM BUILDING.** Any *building* not used for sleeping purposes that is not accessed by the general public and is used primarily for a farm purpose. Farm purposes includes structures or *buildings* for equipment, storage and processing of agricultural products or commodities such as: crops, fruits, vegetables, ornamental or flowering plants, dairy, timber, livestock, poultry and all other such forms of agricultural products by the specific farm on which the structure or *building* is located. Farm purposes do not include structures or *buildings* for uses such as education facilities, research facilities, or aircraft hangers.

The delayed effective date of this Rule is January 1, 2019.  
The Statutory authority for Rule-making is G. S. 143-136; 143-138.

2018 NC Residential Code  
Appendix Q Tiny Houses & R328 Lofts. (210608 Item B-8)  
Replaces “180612 Item B-12” below for “Landing Platform” and “Loft” definitions

**LANDING PLATFORM.** ~~A landing provided as the top step of a *stairway* accessing a *loft*.~~

**LOFT.** ~~A floor level located more than 30 inches (762 mm) above the main floor and open to it on at least one side with a *ceiling height* of less than 6 feet 8 inches (2032 mm), used as a living or sleeping space.~~

The delayed effective date of this Rule is January 1, 2023.  
The Statutory authority for Rule-making is G. S. 143-136; 143-138.

2018 NC Residential Code  
R202, R305, R310, R328 Lofts. (180612 Item B-12)

**LANDING PLATFORM.** A landing provided as the top step of a stairway accessing a loft.

**LOFT.** A floor level located more than 30 inches (762 mm) above the main floor and open to it on at least one side with a ceiling height of less than 6 feet 8 inches (2032 mm), used as a living or sleeping space.

The delayed effective date of this Rule is January 1, 2020.  
The Statutory authority for Rule-making is G. S. 143-136; 143-138.

2018 NC Residential Code  
R101.2.2 Accessory structures. (200901 Item B-19)

**PRIVATE POND.** A body of water owned entirely by a single property owner and located on the same parcel of land as a detached single-family dwelling.

The delayed effective date of this Rule is January 1, 2022.  
The Statutory authority for Rule-making is G. S. 143-136; 143-138.

2018 NC Residential Code  
R302.2 R313.1 & R202 Townhouses. (210608 Item B-7)

**[RB] TOWNHOUSE.** A single-family *dwelling unit* constructed in a group of ~~two~~ three or more attached units separated by property lines in which each unit extends from foundation to roof and with a *yard* or *public way* on not less than two sides.

The delayed effective date of this Rule is January 1, 2023.  
The Statutory authority for Rule-making is G. S. 143-136; 143-138.

**R302.1.1 Soffit protection.** In construction using vinyl or aluminum soffit material, the following application shall apply. Soffit assemblies located on buildings with less than a **10 5** feet (~~3048~~ 1524 mm) fire separation distance shall be securely attached to framing members and applied over fire-retardant-treated wood, 23/32-inch (18.3 mm) wood sheathing or 5/8-inch (15.9 mm) exterior grade or moisture resistant gypsum board. Venting requirements shall be provided in both soffit and underlayments. Vents shall be either nominal 2-inch (51 mm) continuous or equivalent intermittent and shall not exceed the minimum net free air requirements established in Section R806.2 by more than 50 percent. *Townhouse* construction shall meet the additional requirements of Sections R302.2.5 and R302.2.6.

**Exceptions:**

1. Any portion of soffits having **10 5** feet (~~3048~~ 1524 mm) or more *fire separation distance*.
2. Roof rake lines where the soffit does not communicate to the attic are not required to be protected per this section.
3. Soffits with less than 3 feet (914 mm) *fire separation distance* shall meet the projection fire rating requirements of Table R302.1.
4. Soffits between buildings located on the same lot.

The delayed effective date of this Rule is January 1, 2021.  
The Statutory authority for Rule-making is G. S. 143-136; 143-138.

2018 NC Residential Code  
R302.2 R313.1 & R202 Townhouses. (210608 Item B-7)

**R302.2 Townhouses.** Each *townhouse* shall be considered a separate building and shall be separated by fire-resistance rated wall assemblies meeting the requirements of Section ~~R302.1 for exterior walls.~~  
R302.2.1 or R302.2.2.

~~**Exception:** If an automatic residential fire sprinkler is installed, a common 1-hour fire resistance rated wall assembly tested in accordance with ASTM E119 or UL263 is permitted for townhouses if such walls do not contain plumbing or mechanical equipment, *ducts* or *vents* in the cavity of the common wall. The wall shall be rated for fire exposure from both sides and shall extend to and be tight against exterior wall sheathing and the underside of the roof sheathing. Electrical installations shall be installed in accordance with Section R302.4.~~

**R302.2.1 Double walls.** Each *townhouse* shall be separated by two 1-hour fire resistance-rated wall assemblies tested in accordance with ASTM E119, UL263 or Section 703.3 of the 2018 NC Building Code.

**R302.2.2 Common Walls.** Common walls separating *townhouses* shall be assigned a fire-resistance rating in accordance with Item #1 or 2. The common wall shared by two *townhouses* shall be constructed without plumbing or mechanical equipment, *ducts* or *vents* in the cavity of the common wall. The wall shall be rated for fire exposure from both sides and shall extend to and be tight against exterior walls and the underside of the roof sheathing. Electrical installations shall be in accordance with Chapters 34 through 43. Penetrations of the membrane of common walls for electrical outlet boxes shall be in accordance with Section R302. 4.

1. Where a fire sprinkler system in accordance with Section P2904 is provided, the common wall shall be not less than a 1-hour fire-resistance-rated wall assembly tested in accordance with ASTM E119, UL 263 or Section 703.3 of the 2018 NC Building Code.
2. Where a fire sprinkler system in accordance with Section P2904 is not provided, the common wall shall be not less than a 2-hour fire-resistance-rated wall assembly tested in accordance with ASTM E119, UL 263 or Section 703.3 of the 2018 NC Building Code.

**R302.2.5 Townhouse eave protection.** In *townhouse* construction (~~with three or more attached dwellings~~) projections extending into the *fire separation distance* shall have not less than 1-hour fire resistive construction on the underside. Soffit material beyond the *fire separation distance* shall be securely attached to framing members and shall be constructed using either noncombustible soffit material; fire-retardant-treated soffit material; vinyl soffit installed over 3/4-inch (19 mm) wood sheathing or 5/8-inch (15.9 mm) gypsum board; or aluminum soffit installed over 3/4-inch (19 mm) wood sheathing or 5/8-inch (15.9mm) gypsum board. Venting requirements shall be provided in both soffit and underlayments. Vents shall be either nominal 2-inch (51 mm) continuous or equivalent intermittent and shall not exceed the minimum net free air requirements established in Section R806.2 by more than 50 percent. Vents in soffit are not allowed within 4 feet (1219 mm) of fire walls or property lines.

The delayed effective date of this Rule is January 1, 2023.  
The Statutory authority for Rule-making is G. S. 143-136; 143-138.

June 14, 2022



2018 NC Residential Code  
Appendix Q Tiny Houses & R328 Lofts. (210608 Item B-8)  
Replaces “180612 Item B-12” below.

**R305.1 Minimum height.** *Habitable space*, hallways and portions of *basements* containing these spaces shall have a *ceiling height* of not less than 7 feet (2134 mm). *Bathrooms, toilet rooms* and laundry rooms shall have a *ceiling height* of not less than 6 feet 8 inches (2032 mm).

**Exceptions:**

1. For rooms with sloped ceilings, the required floor area of the room shall have a *ceiling height* of not less than 5 feet (1524 mm) and not less than 50 percent of the required floor area shall have a *ceiling height* of not less than 7 feet (2134 mm).
2. The *ceiling height* above bathroom and toilet room fixtures shall be such that the fixture is capable of being used for its intended purpose. A shower or tub equipped with a showerhead shall have a *ceiling height* of not less than 6 feet 8 inches (2032 mm) above an area of not less than 30 inches (762 mm) by 30 inches (762 mm) at the showerhead.
3. Beams, girders, *ducts* or other obstructions in *habitable space* shall be permitted to project to within 6 feet 4 inches (1931 mm) of the finished floor.
4. ~~*Ceiling heights in lofts are permitted to be less than 6 feet 8 inches.*~~

The delayed effective date of this Rule is January 1, 2023.  
The Statutory authority for Rule-making is G. S. 143-136; 143-138.

2018 NC Residential Code  
R202, R305, R310, R328 Lofts. (180612 Item B-12)  
Replaced by “210608 Item B-8” above.

**Section R305**  
**Ceiling Height**

**R305.1 Minimum height.** *Habitable space*, hallways and portions of *basements* containing these spaces shall have a *ceiling height* of not less than 7 feet (2134 mm). *Bathrooms, toilet rooms* and laundry rooms shall have a *ceiling height* of not less than 6 feet 8 inches (2032 mm).

**Exceptions:**

1. For rooms with sloped ceilings, the required floor area of the room shall have a *ceiling height* of not less than 5 feet (1524 mm) and not less than 50 percent of the required floor area shall have a *ceiling height* of not less than 7 feet (2134 mm).
2. The *ceiling height* above bathroom and toilet room fixtures shall be such that the fixture is capable of being used for its intended purpose. A shower or tub equipped with a showerhead shall have a *ceiling height* of not less than 6 feet 8 inches (2032 mm) above an area of not less than 30 inches (762 mm) by 30 inches (762 mm) at the showerhead.
3. Beams, girders, *ducts* or other obstructions in *habitable space* shall be permitted to project to within 6 feet 4 inches (1931 mm) of the finished floor.
4. *Ceiling heights in lofts are permitted to be less than 6 feet 8 inches.*

The delayed effective date of this Rule is January 1, 2020.  
The Statutory authority for Rule-making is G. S. 143-136; 143-138.

2018 NC Residential Code  
R202, R305, R310, R328 Lofts. (180612 Item B-12)

**Section R310**  
**Emergency Escape and Rescue Openings**

**R310.2.6 Egress roof access window.** Egress roof access windows shall be deemed to meet the requirements of Section R310 where installed such that the bottom of the opening is not more than 44 inches (1118 mm) above the floor, provided the egress roof access window complies with the minimum opening area requirements of Section R310.2.1.

The delayed effective date of this Rule is January 1, 2020.  
The Statutory authority for Rule-making is G. S. 143-136; 143-138.

2018 NC Residential Code  
R311.2 Egress Door. (191210 Item B-9)

**R311.2 Egress door.** Not less than one exterior egress door shall be provided for each *dwelling* unit. The egress door shall be side-hinged, and shall provide a clear width of not less than 32 inches (813 mm) where measured between the face of the door and the stop, with the door open 90 degrees (1.57 rad). The clear height of the door opening shall be not less than 78 inches (1981 mm) in height measured from the top of the threshold to the bottom of the stop. Other exterior doors shall not be required to comply with these minimum dimensions. ~~Egress doors shall be readily openable from inside the dwelling.~~ All interior egress doors and a minimum of one exterior egress door shall be readily openable from the side from which egress is to be made without the use of a key or special knowledge or effort.

The delayed effective date of this Rule is January 1, 2021.  
The Statutory authority for Rule-making is G. S. 143-136; 143-138.

2018 NC Residential Code  
R311.7.4 Walkline. (191210 Item B-12)

**R311.7.4** Walkline. ~~Deleted~~ The walkline across winder treads shall be concentric to the curved direction of travel through the turn and located 12 inches (305 mm) from the side where the winders are narrower. The 12 inch (305 mm) dimension shall be measured from the widest point of the clear stair width at the walking surface of the winder. If winders are adjacent within the flight, the point of the widest clear stair width of the adjacent winders shall be used.

The delayed effective date of this Rule is January 1, 2021.  
The Statutory authority for Rule-making is G. S. 143-136; 143-138.

2018 NC Residential Code  
R311.7.5.2.1 Winder Treads. (191210 Item B-12)

**R311.7.5.2.1** Winder treads. Winder treads shall have a minimum tread depth of ~~not less than~~ 9 inches (229 mm) measured ~~between the vertical planes of the foremost projection of adjacent treads at the intersection with the walkline~~ as above a point 12 inches (305 mm) from the side where the treads are narrower. Winder treads shall have a minimum tread depth of ~~not less than~~ 4 inches (102 mm) at any point ~~within the clear width of the stair~~. Within any flight of stairs, the ~~largest~~ greatest winder tread depth at the 12 inch (305 mm) walkline shall not exceed the smallest ~~winder tread~~ by more than 3/8 inch (9.5 mm).

The delayed effective date of this Rule is January 1, 2021.  
The Statutory authority for Rule-making is G. S. 143-136; 143-138.

2018 NC Residential Code  
R311.7.5.3 Nosings. (191210 Item B-10)

**R311.7.5.3 Nosings.** The radius of curvature at the nosing shall be not greater than 9/16 inch (14 mm). A nosing projection not less than 3/4 inch (19 mm) and not more than 1 1/4 inches (32 mm) shall be provided on stairways with solid risers. The greatest nosing projection shall not exceed the smallest nosing projection by more than 3/8 inch (9.5 mm) between two stories, including the nosing at the level of floors and landings. Beveling of nosings shall not exceed 1/2 inch (12.7 mm).

**Exceptions:**

1. A nosing projection is not required where the tread depth is not less than 11 inches (279 mm).
2. ~~The opening between adjacent treads is not limited on stairs with a total rise of 30 inches (762 mm) or less.~~

The delayed effective date of this Rule is January 1, 2021.  
The Statutory authority for Rule-making is G. S. 143-136; 143-138.

2018 NC Residential Code  
R311.7.8.1 Height. (190910 Item B-15)

**R311.7.8.1 Height.** Handrail height, measured vertically from the sloped plane adjoining the tread nosing, or finish surface of ramp slope, shall be not less than 34 inches (864 mm) and not more than 38 inches (965 mm).

**Exceptions:**

1. The use of a volute, turnout, ~~or starting easing~~ or starting newel shall be allowed over the lowest tread.
2. When handrail fittings or bendings are used to provide continuous transition between flights, the transition from handrail to *guard*, or used at the start of a flight, the handrail height at the fittings or bendings shall be permitted to exceed the maximum height.

The delayed effective date of this Rule is January 1, 2021.  
The Statutory authority for Rule-making is G. S. 143-136; 143-138.

2018 NC Residential Code  
R312.1.2 Height. (191210 Item B-10)

**R312.1.2 Height.** Required *guards* at open-sided walking surfaces, including stairs, porches, balconies or landings, shall be not less than 36 inches (914 mm) in height as measured vertically above the adjacent walking surface or the line connecting the leading edges of the treads. Open risers are permitted, provided that the opening between treads does not permit the passage of a 4-inch diameter (102 mm) sphere.

**Exceptions:**

1. *Guards* on the open sides of stairs shall have a height not less than 34 inches (864 mm) measured vertically from a line connecting the leading edges of the treads.
2. Where the top of the *guard* serves as a handrail on the open sides of stairs, the top of the *guard* shall be not less than 34 inches (864 mm) and not more than 38 inches (965 mm) as measured vertically from a line connecting the leading edges of the treads.
3. Open risers that prevent the passage of a 4-inch (102 mm) diameter sphere.

The delayed effective date of this Rule is January 1, 2021.  
The Statutory authority for Rule-making is G. S. 143-136; 143-138.

June 14, 2022



2018 NC Residential Code  
R312.1.3 Opening Limitations. (191210 Item B-10)

**R312.1.3 Opening limitations.** Required *guards* shall not have openings from the walking surface to the required *guard* height that allow passage of a sphere 4 inches (102 mm) in diameter.

**Exceptions:**

1. The triangular openings at the open side of stair, formed by the riser, tread and bottom rail of a *guard*, shall not allow passage of a sphere 6 inches (153 mm) in diameter.

2. *Guards* on the open side of stairs shall not have openings that allow passage of a sphere 4 3/8 inches (111 mm) in diameter.

3. The opening between adjacent treads is not limited on stairs with a total rise of 30 inches (762 mm) or less.

The delayed effective date of this Rule is January 1, 2021.  
The Statutory authority for Rule-making is G. S. 143-136; 143-138.

2018 NC Residential Code  
R302.2 R313.1 & R202 Townhouses. (210608 Item B-7)

### **R313.1 Townhouse automatic fire sprinkler systems. (Deleted)**

An automatic residential fire sprinkler system shall be installed in *townhouses*.

#### **Exceptions:**

- ~~1. Townhouses constructed with a common 2-hour fire resistance-rated wall assembly tested in accordance with ASTM E119 or UL 263, provided such walls do not contain plumbing or mechanical equipment, *ducts* or *vents* in the cavity of the common wall. The wall shall be rated for fire exposure from both sides and shall extend to and be tight against exterior wall sheathing and the underside of the roof sheathing. Electrical installations shall be installed in accordance with the *North Carolina Electrical Code*. Penetrations for electrical outlet boxes shall be in accordance with Section R302.4.~~
2. An automatic residential fire sprinkler system shall not be required where *additions* or *alterations* are made to existing *townhouses* that do not have an automatic residential fire sprinkler system installed

The delayed effective date of this Rule is January 1, 2023.  
The Statutory authority for Rule-making is G. S. 143-136; 143-138.

2018 NC Residential Code  
R101.2.2 Accessory structures. (200901 Item B-19)

## **SECTION R327 DOCKS, PIERS, BULKHEADS AND WATERWAY STRUCTURES**

### **R327.1 General.**

*Docks, piers, bulkheads* and waterway structures shall be constructed in accordance with Chapter 36 of the *North Carolina Building Code*.

**Exceptions:** Structures complying with the following are not required to meet the provisions of this code.

1. *Docks and Piers built over private ponds.*
2. Fixed in place walkways, *docks*, and *piers* not covered in Exception 1 and not exceeding 144 square feet for single family dwelling.
3. Minor repairs to existing *docks, piers* and waterway structures.
  - ~~1. Fixed piers associated with a one or two family dwelling meeting all of the following:~~
    - 1.1. A maximum of four boat slips for a single owner of a one or two family dwelling or two adjacent, riparian owners.
    - 1.2. A maximum height of 15 feet (4572 mm) measured from deck to mud line at any location along the pier.
    - 1.3. A maximum normal pool depth of 13 feet (3962 mm) on lakes and ponds and a maximum mean low water depth of 7 feet (2134 mm) in other locations.
    - 1.4. A maximum walkway width of 6 feet (1829 mm).
    - 1.5. A maximum pile spacing of 8 feet (2438 mm), in both directions.
    - 1.6. A maximum of 576 sq. ft. (53.5 m<sup>2</sup>) for non walkways areas.
    - 1.7. A maximum boat slip length of 40 feet (12.2 m).
    - 1.8. A maximum roofed area of 576 sq. ft. (53.5 m<sup>2</sup>) with an additional maximum 2 foot (610 mm) overhang.
    - 1.9. Constructed with no enclosed or multilevel structures.
    - 1.10. Supports a boatlift with a maximum design capacity no greater than 16,000 pounds (71.2 kN).
  2. Floating docks associated with a one or two family dwelling meeting all of the following:
    - 2.1. A maximum of four boat slips for a single owner of a one or two family dwelling or two adjacent, riparian owners.
    - 2.2. A maximum normal pool depth of 20 feet (6096 mm) for docks with guide piles on lakes and ponds and a maximum mean low water of 10 feet (3048 mm) for docks with guide piles in other locations.
    - 2.3. A maximum boat slip length of 40 feet (12.2 m).

June 14, 2022

2.4. Finger piers, crosswalks or other floating surfaces having a minimum width of 3 feet (914 mm) wide to a maximum of 6 feet (1829 mm) wide, except for a single 8 foot x 16 foot (2438 mm x 4877 mm) section.

2.5. When constructed with a roof the following conditions exist:

- i. Ultimate design wind speed is 115 mph (51 m/s) or less;
- ii. Roof load is 20 psf (0.96 kPa) or less;
- iii. A maximum eave height of 10 feet (3048 mm);
- iv. A maximum roof slope of 4:12;
- v. A maximum roofed area of 576 sq. ft. (53.5 m<sup>2</sup>) with an additional maximum 2 foot (610 mm) overhang;
- vi. A minimum boat slip width of 12 feet (3658 mm);
- vii. A minimum floating dock width of 4 feet (1219 mm) along both sides of the boat slip;
- viii. A maximum dead load of 12 psf (0.57 kPa);
- ix. Floating structures supporting roof structures are balanced or anchored to reduce the possibility of tipping.

2.6. Constructed with no enclosed or multilevel structures.

2.7. Supports a boat lift with a maximum design capacity no greater than 16,000 pounds (71.2 kN).2018

The delayed effective date of this Rule is January 1, 2022.

The Statutory authority for Rule-making is G. S. 143-136; 143-138.

2018 NC Residential Code  
Appendix Q Tiny Houses & R328 Lofts. (210608 Item B-8)  
Replaces “180612 Item B-12” below.

## **Section R328 Lofts**

**R328.1 Minimum loft area and dimensions.** *Lofts* used as a sleeping or living space shall meet the minimum area and dimension requirements of Sections R328.1.1 through R328.1.4.

**R328.1.1 Minimum area.** *Lofts* shall have floor area of not less than 35 square feet (3.25 m<sup>2</sup>).

**R328.1.2 Maximum area.** *Lofts* shall have a floor area not greater than 70 square feet (6.50 m<sup>2</sup>).

**R328.1.3 Minimum dimensions.** *Lofts* shall not be less than 5 feet (1524 mm) in any horizontal dimension.

**R328.1.4 Height effect on loft area.** Portions of a *loft* with a sloping ceiling measuring less than 3 feet (914 mm) from the finished floor to the finished ceiling shall not be considered as contributing to the minimum required area for the *loft*.

**Exception:** Under gable roofs with a minimum slope of 6 units vertical in 12 units horizontal (50 percent slope) portions of a *loft* with a sloped ceiling measuring less than 16 inches (406 mm) from the finished floor to the finished ceiling shall not be considered as contributing to the minimum required area for the *loft*.

**R328.2 Loft access.** The access to and primary egress from *lofts* shall be any type described in Sections R328.2.1 through R328.2.4.

**R328.2.1 Stairways.** *Stairways* accessing *lofts* shall comply with this code or with Sections R328.2.1.1 through R328.2.1.5.

**R328.2.1.1 Width.** *Stairways* accessing a *loft* shall not be less than 17 inches (432 mm) in clear width at or above the *handrail*. The minimum below the *handrail* shall be not less than 20 inches (508 mm).

**R328.2.1.2 Headroom.** The headroom in *stairways* accessing a *loft* shall be not less than 6 feet 2 inches (1880 mm), as measured vertically, from a sloped line connecting the tread or *landing platform nosings* in the middle of their width.

**R328.2.1.3 Treads and Risers.** *Risers* for *stairs* accessing a *loft* shall be not less than 7 inches (178 mm) and not more than 12 inches (305 mm) in height. Tread depth and *riser* height shall be calculated in accordance with one of the following formulas:

1. The tread depth shall be 20 inches (508 mm) minus  $\frac{4}{3}$  of the *riser* height; or
2. The *riser* height shall be 15 inches (381 mm) minus  $\frac{3}{4}$  of the tread depth.

**R328.2.1.4 Landing platforms.** The top tread and *riser* of *stairways* accessing *lofts* shall be constructed as a *landing platform* where the *loft ceiling height* is less than 6 feet 2 inches (1880 mm) where the *stairway* meets the *loft*. The *landing platform* shall be 18 inches to 22 inches (457 to 559 mm) in depth measured from the *nosing* of the *landing platform* to the edge of the *loft*, and 16 to 18 inches (406 to 457 mm) in height measured from the *landing platform* to the *loft floor*.

**R328.2.1.5 Handrails.** *Handrails* shall comply with Section R311.7.8.

**R328.2.1.6 Stairway guards.** *Guards* at open sides of *stairways* shall comply with Section R312.1.

**R328.2.2 Ladders.** Ladders accessing *lofts* shall comply with Sections R328.2.2.1 and R328.2.2.2.

**R328.2.2.1 Size and capacity.** Ladders accessing *lofts* shall have a rung width of not less than 12 inches (305 mm) and 10 inches (254 mm) to 14 inches (356 mm) spacing between rungs. Ladders shall be capable of supporting a 200 pound (75 kg) load on any rung. Rung spacing shall be uniform within 3/8 inch (9.5 mm).

**R328.2.2.2 Incline.** Ladders shall be installed at 70 to 80 degrees from horizontal.

**R328.2.4 Ships ladders.** Ships ladders accessing *lofts* shall comply with Sections R311.7.12.1 and R311.7.12.2. The clear width at and below *handrails* shall be not less than 20 inches (508 mm).

**R328.2.5 Loft Guards.** *Loft guards* shall be located along the open side of *lofts*. *Loft guards* shall not be less than 36 inches (914 mm) in height or one half of the clear height to the ceiling, whichever is less.

The delayed effective date of this Rule is January 1, 2023.

The Statutory authority for Rule-making is G. S. 143-136; 143-138.

## **Section R328**

### **Lofts**

**R328.1 Minimum loft area and dimensions.** *Lofts* used as a sleeping or living space shall meet the minimum area and dimension requirements of Sections R328.1.1 through R328.1.4.

**R328.1.1 Minimum area.** *Lofts* shall have floor area of not less than 35 square feet (3.25 m<sup>2</sup>).

**R328.1.2 Maximum area.** *Lofts* shall have a floor area not greater than 70 square feet (6.50 m<sup>2</sup>).

**R328.1.3 Minimum dimensions.** *Lofts* shall not be less than 5 feet (1524 mm) in any horizontal dimension.

**R328.1.4 Height effect on loft area.** Portions of a *loft* with a sloping ceiling measuring less than 3 feet (914 mm) from the finished floor to the finished ceiling shall not be considered as contributing to the minimum required area for the *loft*.

**Exception:** Under gable roofs with a minimum slope of 6 units vertical in 12 units horizontal (50-percent slope) portions of a *loft* with a sloped ceiling measuring less than 16 inches (406 mm) from the finished floor to the finished ceiling shall not be considered as contributing to the minimum required area for the *loft*.

**R328.2 Loft access.** The access to and primary egress from *lofts* shall be any type described in Sections R328.2.1 through R328.2.4.

**R328.2.1 Stairways.** Stairways accessing *lofts* shall comply with this code or with Sections R328.2.1.1 through R328.2.1.5.

**R328.2.1.1 Width.** Stairways accessing a *loft* shall not be less than 17 inches (432 mm) in clear width at or above the handrail. The minimum below the handrail shall be not less than 20 inches (508 mm).

**R328.2.1.2 Headroom.** The headroom in stairways accessing a *loft* shall be not less than 6 feet 2 inches (1880 mm), as measured vertically, from a sloped line connecting the tread or landing platform nosings in the middle of their width.

**R328.2.1.3 Treads and Risers.** Risers for stairs accessing a *loft* shall be not less than 7 inches (178 mm) and not more than 12 inches (305 mm) in height. Tread depth and riser height shall be calculated in accordance with one of the following formulas:

1. The tread depth shall be 20 inches (508 mm) minus  $\frac{4}{3}$  of the riser height; or
2. The riser height shall be 15 inches (381 mm) minus  $\frac{3}{4}$  of the tread depth.

**R328.2.1.4 Landing platforms.** The top tread and riser of stairways accessing *lofts* shall be constructed as a landing platform where the *loft* ceiling height is less than 6 feet 2 inches (1880 mm) where the stairway meets the *loft*. The landing platform shall be 18 inches to 22 inches (457 to 559 mm) in depth measured from the nosing of the landing platform to the edge of the *loft*, and 16 to 18 inches (406 to 457 mm) in height measured from the landing platform to the *loft* floor.

**R328.2.1.5 Handrails.** Handrails shall comply with Section R311.7.8.

**R328.2.1.6 Stairway guards.** Guards at open sides of stairways shall comply with Section R312.1.

**R328.2.2 Ladders.** Ladders accessing *lofts* shall comply with Sections R328.2.2.1 and R328.2.2.2.

**R328.2.2.1 Size and capacity.** Ladders accessing *lofts* shall have a rung width of not less than 12 inches (305 mm) and 10 inches (254 mm) to 14 inches (356 mm) spacing between rungs. Ladders shall be capable of supporting a 200 pound (75 kg) load on any rung. Rung spacing shall be uniform within 3/8-inch (9.5 mm).

**R328.2.2.2 Incline.** Ladders shall be installed at 70 to 80 degrees from horizontal.

**R328.2.4 Ships ladders.** Ships ladders accessing *lofts* shall comply with Sections R311.7.12.1 and R311.7.12.2. The clear width at and below handrails shall be not less than 20 inches (508 mm).

**R328.2.5 Loft Guards.** *Loft* guards shall be located along the open side of *lofts*. *Loft* guards shall not be less than 36 inches (914 mm) in height or one-half of the clear height to the ceiling, whichever is less.

The delayed effective date of this Rule is January 1, 2020.

The Statutory authority for Rule-making is G. S. 143-136; 143-138.

2018 NC Residential Code  
R328 Demolition. (200714 Item B-20)

**ERRATA** – Changed Section number from R328 to R329 because R328 was already used

**SECTION R329 DEMOLITION**

**R328.1 Demolition.** Where a building or structure regulated by this code has been demolished or removed, the lot shall not create a new hazard to the site or to adjoining properties. All utilities shall be properly terminated.

The delayed effective date of this Rule is January 1, 2022.  
The Statutory authority for Rule-making is G. S. 143-136; 143-138.

June 14, 2022



2018 NC Residential Code  
R403.1.6 Foundation Anchorage. (190312 Item B-18)

Exceptions:

1. Walls 24 inches (610 mm) total length or shorter connecting offset braced wall panels shall be anchored to the foundation with a minimum of one anchor bolt located in the center third of the plate section and shall be attached to adjacent braced wall panels at corners as shown in Table R602.3(1) and Figure R602.10.3(5).
2. Connection of walls 12 inches (305 mm) total length or shorter connecting offset *braced wall panels* to the foundation without anchor bolts shall be permitted. The wall shall be attached to adjacent braced wall panels at corners as shown in Table R602.3(1) and Figure R602.10.3(5).

The delayed effective date of this Rule is January 1, 2021.  
The Statutory authority for Rule-making is G. S. 143-136; 143-138.

2018 NC Residential Code  
R404.4 Retaining walls. (200714 Item B-18)

**R404.4 Retaining walls.** Retaining walls ~~that are not laterally supported at the top and that retain in excess of 48 inches (1219 mm) of unbalanced fill, shall be designed to ensure stability against overturning, sliding, excessive foundation pressure and water uplift. In addition, any retaining wall that meets~~ meet the following shall be designed by a registered design professional.

1. Any retaining wall systems on a residential site that cross over adjacent property lines regardless of vertical height, ~~and~~
2. Retaining walls that support *buildings* and their *accessory structures*;
3. Retaining walls exceeding 4 feet (1524 mm) of unbalanced backfill height, or
4. Retaining wall systems providing a cumulative vertical relief greater than 5 feet (1524 mm) in height within a horizontal distance of 50 feet (15 m) or less.

Retaining walls shall be designed for a safety factor of 1.5 against lateral sliding and overturning.

The delayed effective date of this Rule is January 1, 2022.  
The Statutory authority for Rule-making is G. S. 143-136; 143-138.

2018 NC Residential Code  
R404.4 Retaining Walls (210914 Item B-1)

**R404.4 Retaining Walls.** Retaining walls that meet the following shall be designed by a *registered design professional.*

1. Any retaining walls ~~systems~~ on a residential site that cross over adjacent property lines regardless of vertical height, or
2. Retaining walls that support buildings and their *accessory structures*, undercutting footings 10 feet or less per R403.1.9 and Figure 403.1.9, or
3. ~~Retaining~~ Individual retaining walls supporting unbalanced backfill exceeding 4 feet (1219mm) 5 feet (1524 mm) of unbalanced backfill in height within a horizontal distance of 15 feet (4572 mm) or less, or
4. ~~Retaining~~ Multiple retaining walls systems providing a cumulative vertical relief of unbalanced backfill heights greater than 5 feet (1524 mm) in height within a horizontal distance of 50 feet (15M) 15 feet (4572 mm) or less.

Retaining walls shall be designed for a safety factor of 1.5 against lateral sliding and overturning.

The delayed effective date of this Rule is January 1, 2025.  
The Statutory authority for Rule-making is G. S. 143-136; 143-138.

2018 NC Residential Code  
R506.2.1 Fill. (190611 Item B-9)

**R506.2.1 Fill.** Fill material shall be free of vegetation and foreign material. The fill shall be compacted to ensure uniform support of the slab, and except where *approved*, the fill depths shall not exceed 24 inches (610 mm) for clean sand or gravel and 8 inches (203 mm) for earth.

**Exception:** #57 or #67 stone may be used as fill without a compaction test for a maximum depth of 4 feet.

The delayed effective date of this Rule is January 1, 2021.  
The Statutory authority for Rule-making is G. S. 143-136; 143-138.

June 14, 2022

2018 NC Residential Code  
 Tables R602.3(3), R602.10.1 and R602.10.3, (200310 Item B-11)

TABLE R602.3(3)  
 REQUIREMENTS FOR WOOD STRUCTURAL PANEL WALL SHEATHING USED TO RESIST WIND PRESSURES<sup>a b c</sup>





MINIMUM NAIL		MINIMUM WOOD STRUCTURAL PANEL SPAN RATING	MINIMUM NOMINAL PANEL THICKNESS (inches)	MAXIMUM WALL STUD SPACING (inches)	PANEL NAIL SPACING		ULTIMATE DESIGN WIND SPEED V <sub>ult</sub> (mph)		
Size	Penetration (inches)				Edges (inches o.c.)	Field (inches o.c.)	Wind exposure category		
							B	C	D
6d Common (2.0" X 0.113")	1.5	24/0	3/8	16	6	12	140	115	110
8d Common (2.5" x 0.131")	1.75	24/16	7/16	16	6	12	170	140	135
				24	6	12	140	115	110

For SI: 1 inch = 25.4 mm, 1 mile per hour = 0.447 m/s.

- a. Panel strength axis parallel or perpendicular to supports. Three-ply plywood sheathing with studs spaced more than 16 inches on center shall be applied with panel strength axis perpendicular to supports.
- b. Table is based on wind pressures acting toward and away from building surfaces in accordance with Section R301.2. Lateral bracing requirements shall be in accordance with Section R602.10.
- c. Wood structural panels with span ratings of Wall-16 or Wall-24 shall be permitted as an alternate to panels with a 24/0 span rating. Plywood siding rated 16 o.c. or 24 o.c. shall be permitted as an alternate to panels with a 24/16 span rating. Wall-16 and Plywood siding 16 o.c. shall be used with studs spaced not more than 16 inches on center.

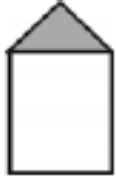
The delayed effective date of this Rule is January 1, 2021.  
 The Statutory authority for Rule-making is G. S. 143-136; 143-138.

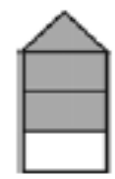
**TABLE R602.3(5)  
 SIZE, HEIGHT AND SPACING OF WOOD STUDS<sup>a,d</sup>**

STUD SIZE (inches)	BEARING WALLS					NONBEARING WALLS	
	Laterally unsupported stud height <sup>a</sup> (feet)	Maximum spacing when supporting a roof-ceiling assembly or a habitable attic assembly, only (inches)	Maximum spacing when supporting one floor, plus a roof-ceiling assembly or a habitable attic assembly (inches)	Maximum spacing when supporting two floors, plus a roof-ceiling assembly or a habitable attic assembly (inches)	Maximum spacing when supporting one floor height <sup>a</sup> (inches)	Laterally unsupported stud height <sup>a</sup> (feet)	Maximum spacing (inches)
							
2 × 3 <sup>b</sup>	—	—	—	—	—	10	16
2 × 4	10	24 <sup>c</sup>	16 <sup>c</sup>	e d	24	14	24
3 × 4	10	24	24	16	24	14	24
2 × 5	10	24	24	—	24	16	24
2 × 6	10	24	24	16	24	20	24

For SI: 1 inch = 25.4 mm, 1 foot = 304.8 mm.

- a. Listed heights are distances between points of lateral support placed perpendicular to the plane of the wall. Bearing walls shall be sheathed on not less than one side or bridging shall be installed not greater than 4 feet apart measured vertically from either end of the stud. Increases in unsupported height are permitted where in compliance with Exception 2 of Section R602.3.1 or designed in accordance with accepted engineering practice.
- b. Shall not be used in exterior walls.
- c. A habitable attic assembly supported by 2 × 4 studs is limited to a roof span of 32 feet. Where the roof span exceeds 32 feet, the wall studs shall be increased to 2 × 6 or the studs shall be designed in accordance with accepted engineering practice.
- d. ~~One half of the studs interrupted by a wall opening shall be placed immediately outside the jack studs on each side of the opening as king studs to resist wind loads. King studs shall extend full height from sole plate to top plate of the wall.~~
- e d. 2 x 4 studs at 12 inches maximum spacing are permitted in accordance with Table R4505(b).

The delayed effective date of this Rule is January 1, 2021.  
 The Statutory authority for Rule-making is G. S. 143-136; 143-138.

**ERRATA** – moved superscript “b” adjacent to “southern pine”

**TABLE R602.7(1)**  
**GIRDER SPANS<sup>a</sup> AND HEADER SPANS<sup>a</sup> FOR EXTERIOR BEARING WALLS**  
(Maximum spans for Douglas fir-larch, hem-fir, **southern pine<sup>b</sup>** and spruce-pine-fir and required number of jack studs)

b. No. 1 or better grade lumber shall be used for southern pine. Other Tabulated values assume #2 grade lumber.

**TABLE R602.7(2)**  
**GIRDER SPANS<sup>a</sup> AND HEADER SPANS<sup>a</sup> FOR INTERIOR BEARING WALLS**  
(Maximum spans for Douglas fir-larch, hem-fir, **southern pine<sup>b</sup>** and spruce-pine-fir and required number of jack studs)



b. No. 1 or better grade lumber shall be used for southern pine. Other Tabulated values assume #2 grade lumber.

2018 NC Residential Code

**ERRATA** – added **highlighted figures** to Tables R602.7(1) and R602.7(2) on pages 127-129.

TABLE R602.7(1)  
**GIRDER SPANS<sup>a</sup> AND HEADER SPANS<sup>b</sup> FOR EXTERIOR BEARING WALLS**  
 (Maximum spans for Douglas fir-larch, hem-fir, southern pine and spruce-pine-fir<sup>b</sup> and required number of jack studs)



\*\*\*

GIRDERS AND HEADERS SUPPORTING	SIZE	GROUND SNOW LOAD (psf) <sup>c</sup>																								
		30						50						70												
		Building width <sup>e</sup> (feet)																								
		20			28			36			20			28			36			20			28			36
Span	NJ <sup>d</sup>	Span	NJ <sup>d</sup>	Span	NJ <sup>d</sup>	Span	NJ <sup>d</sup>	Span	NJ <sup>d</sup>	Span	NJ <sup>d</sup>	Span	NJ <sup>d</sup>	Span	NJ <sup>d</sup>	Span	NJ <sup>d</sup>	Span	NJ <sup>d</sup>	Span	NJ <sup>d</sup>	Span	NJ <sup>d</sup>	Span	NJ <sup>d</sup>	
Roof and ceiling 	1-2 x 8	4-6	1	3-10	1	3-5	1	3-9	1	3-2	1	2-10	2	—	—	—	—	—	—	—	—	—	—	—	—	—
	1-2 x 10	5-8	1	4-11	1	4-4	1	4-9	1	4-1	1	3-7	2	—	—	—	—	—	—	—	—	—	—	—	—	—
	1-2 x 12	6-11	1	5-11	2	5-3	2	5-9	2	4-8	2	3-8	2	—	—	—	—	—	—	—	—	—	—	—	—	—
	2-2 x 4	3-6	1	3-2	1	2-10	1	3-2	1	2-9	1	2-6	1	2-10	1	2-6	1	2-3	1	2-3	1	—	—	—	—	—
	2-2 x 6	5-5	1	4-8	1	4-2	1	4-8	1	4-1	1	3-8	2	4-2	1	3-8	2	3-3	2	3-3	2	—	—	—	—	—
	2-2 x 8	6-10	1	5-11	2	5-4	2	5-11	2	5-2	2	4-7	2	5-4	2	4-7	2	4-1	2	4-1	2	—	—	—	—	—
	2-2 x 10	8-5	2	7-3	2	6-6	2	7-3	2	6-3	2	5-7	2	6-6	2	5-7	2	5-0	2	5-0	2	—	—	—	—	—
	2-2 x 12	9-9	2	8-5	2	7-6	2	8-5	2	7-3	2	6-6	2	7-6	2	6-6	2	5-10	3	5-10	3	—	—	—	—	—
	3-2 x 8	8-4	1	7-5	1	6-8	1	7-5	1	6-5	2	5-9	2	6-8	1	5-9	2	5-2	2	5-2	2	—	—	—	—	—
	3-2 x 10	10-6	1	9-1	2	8-2	2	9-1	2	7-10	2	7-0	2	8-2	2	7-0	2	6-4	2	6-4	2	—	—	—	—	—
	3-2 x 12	12-2	2	10-7	2	9-5	2	10-7	2	9-2	2	8-2	2	9-5	2	8-2	2	7-4	2	7-4	2	—	—	—	—	—
	4-2 x 8	9-2	1	8-4	1	7-8	1	8-4	1	7-5	1	6-8	1	7-8	1	7-8	1	7-11	2	7-11	2	—	—	—	—	—
	4-2 x 10	11-8	1	10-6	1	9-5	2	10-6	1	9-1	2	8-2	2	9-5	2	8-2	2	7-3	2	7-3	2	—	—	—	—	—
	4-2 x 12	14-1	1	12-2	2	10-11	2	12-2	2	10-7	2	9-5	2	10-11	2	9-5	2	8-5	2	8-5	2	—	—	—	—	—
Roof, ceiling and one center-bearing floor 	1-2 x 8	3-11	1	3-5	1	3-0	1	3-7	1	3-0	2	2-8	2	—	—	—	—	—	—	—	—	—	—	—	—	—
	1-2 x 10	5-0	2	4-4	2	3-10	2	4-6	2	3-11	2	3-4	2	—	—	—	—	—	—	—	—	—	—	—	—	—
	1-2 x 12	5-10	2	4-9	2	4-2	2	5-5	2	4-2	2	3-4	2	—	—	—	—	—	—	—	—	—	—	—	—	—
	2-2 x 4	3-1	1	2-9	1	2-5	1	2-9	1	2-5	1	2-2	1	2-7	1	2-3	1	2-0	1	2-0	1	—	—	—	—	—
	2-2 x 6	4-6	1	4-0	1	3-7	2	4-1	1	3-7	2	3-3	2	3-9	2	3-3	2	2-11	2	2-11	2	—	—	—	—	—
	2-2 x 8	5-9	2	5-0	2	4-6	2	5-2	2	4-6	2	4-1	2	4-9	2	4-2	2	3-9	2	3-9	2	—	—	—	—	—
	2-2 x 10	7-0	2	6-2	2	5-6	2	6-4	2	5-6	2	5-0	2	5-9	2	5-1	2	4-7	3	4-7	3	—	—	—	—	—
	2-2 x 12	8-1	2	7-1	2	6-5	2	7-4	2	6-5	2	5-9	3	6-8	2	5-10	3	5-3	3	5-3	3	—	—	—	—	—
	3-2 x 8	7-2	1	6-3	2	5-8	2	6-5	2	5-8	2	5-1	2	5-11	2	5-2	2	4-8	2	4-8	2	—	—	—	—	—
	3-2 x 10	8-9	2	7-8	2	6-11	2	7-11	2	6-11	2	6-3	2	7-3	2	6-4	2	5-8	2	5-8	2	—	—	—	—	—
	3-2 x 12	10-2	2	8-11	2	8-0	2	9-2	2	8-0	2	7-3	2	8-5	2	7-4	2	6-7	2	6-7	2	—	—	—	—	—
	4-2 x 8	8-1	1	7-3	1	6-7	1	7-5	1	6-6	1	5-11	2	6-10	1	6-0	2	5-5	2	5-5	2	—	—	—	—	—
	4-2 x 10	10-1	1	8-10	2	8-0	2	9-1	2	8-0	2	7-2	2	8-4	2	7-4	2	6-7	2	6-7	2	—	—	—	—	—
	4-2 x 12	11-9	2	10-3	2	9-3	2	10-7	2	9-3	2	8-4	2	9-8	2	8-6	2	7-7	2	7-7	2	—	—	—	—	—
Roof, ceiling and one clear span floor 	1-2 x 8	3-6	1	3-0	1	2-8	1	3-5	1	2-11	1	2-7	2	—	—	—	—	—	—	—	—	—	—	—	—	—
	1-2 x 10	4-6	1	3-10	1	3-3	1	4-4	1	3-9	1	3-1	2	—	—	—	—	—	—	—	—	—	—	—	—	—
	1-2 x 12	5-6	1	4-2	2	3-3	2	5-4	2	3-11	2	3-1	2	—	—	—	—	—	—	—	—	—	—	—	—	—
	2-2 x 4	2-8	1	2-4	1	2-1	1	2-7	1	2-3	1	2-0	1	2-5	1	2-1	1	1-10	1	1-10	1	—	—	—	—	—
	2-2 x 6	3-11	1	3-5	2	3-0	2	3-10	2	3-4	2	3-0	2	3-6	2	3-1	2	2-9	2	2-9	2	—	—	—	—	—
	2-2 x 8	5-0	2	4-4	2	3-10	2	4-10	2	4-2	2	3-9	2	4-6	2	3-11	2	3-6	2	3-6	2	—	—	—	—	—
	2-2 x 10	6-1	2	5-3	2	4-8	2	5-11	2	5-1	2	4-7	3	5-6	2	4-9	2	4-3	3	4-3	3	—	—	—	—	—
	2-2 x 12	7-1	2	6-1	3	5-5	3	6-10	2	5-11	3	5-4	3	6-4	2	5-6	3	5-0	3	5-0	3	—	—	—	—	—
	3-2 x 8	6-3	2	5-5	2	4-10	2	6-1	2	5-3	2	4-8	2	5-7	2	4-11	2	4-5	2	4-5	2	—	—	—	—	—
	3-2 x 10	7-7	2	6-7	2	5-11	2	7-5	2	6-5	2	5-9	2	6-10	2	6-0	2	5-4	2	5-4	2	—	—	—	—	—
	3-2 x 12	8-10	2	7-8	2	6-10	2	8-7	2	7-5	2	6-8	2	7-11	2	6-11	2	6-3	2	6-3	2	—	—	—	—	—
	4-2 x 8	7-2	1	6-3	2	5-7	2	7-0	1	6-1	2	5-5	2	6-6	1	5-8	2	5-1	2	5-1	2	—	—	—	—	—
	4-2 x 10	8-9	2	7-7	2	6-10	2	8-7	2	7-5	2	6-7	2	7-11	2	6-11	2	6-2	2	6-2	2	—	—	—	—	—
	4-2 x 12	10-2	2	8-10	2	7-11	2	9-11	2	8-7	2	7-8	2	9-2	2	8-0	2	7-2	2	7-2	2	—	—	—	—	—

(continued)

WALL CONSTRUCTION

**TABLE R602.7(1)—continued**  
**GIRDER SPANS<sup>a</sup> AND HEADER SPANS<sup>a</sup> FOR EXTERIOR BEARING WALLS**  
 (Maximum spans for Douglas fir-larch, hem-fir, southern pine and spruce-pine-fir<sup>b</sup> and required number of jack studs)

GIRDERS AND HEADERS SUPPORTING	SIZE	GROUND SNOW LOAD (psf) <sup>c</sup>																															
		30						50						70																			
		Building width <sup>e</sup> (feet)																															
		20			28			36			20			28			36			20			28			36							
Span	NJ <sup>d</sup>		Span	NJ <sup>d</sup>		Span	NJ <sup>d</sup>		Span	NJ <sup>d</sup>		Span	NJ <sup>d</sup>		Span	NJ <sup>d</sup>		Span	NJ <sup>d</sup>		Span	NJ <sup>d</sup>		Span	NJ <sup>d</sup>		Span	NJ <sup>d</sup>					
Roof, ceiling and two center-bearing floors 	2-2 x 4	2-7	1	2-3	1	2-0	1	2-6	1	2-2	1	1-11	1	2-4	1	2-0	1	1-9	1														
	2-2 x 6	3-9	2	3-3	2	2-11	2	3-8	2	3-2	2	2-10	2	3-5	2	3-0	2	2-8	2														
	2-2 x 8	4-9	2	4-2	2	3-9	2	4-7	2	4-0	2	3-8	2	4-4	2	3-9	2	3-5	2														
	2-2 x 10	5-9	2	5-1	2	4-7	3	5-8	2	4-11	2	4-5	3	5-3	2	4-7	3	4-2	3														
	2-2 x 12	6-8	2	5-10	3	5-3	3	6-6	2	5-9	3	5-2	3	6-1	3	5-4	3	4-10	3														
	3-2 x 8	5-11	2	5-2	2	4-8	2	5-9	2	5-1	2	4-7	2	5-5	2	4-9	2	4-3	2														
	3-2 x 10	7-3	2	6-4	2	5-8	2	7-1	2	6-2	2	5-7	2	6-7	2	5-9	2	5-3	2														
	3-2 x 12	8-5	2	7-4	2	6-7	2	8-2	2	7-2	2	6-5	3	7-8	2	6-9	2	6-1	3														
	4-2 x 8	6-10	1	6-0	2	5-5	2	6-8	1	5-10	2	5-3	2	6-3	2	5-6	2	4-11	2														
	4-2 x 10	8-4	2	7-4	2	6-7	2	8-2	2	7-2	2	6-5	2	7-7	2	6-8	2	6-0	2														
	4-2 x 12	9-8	2	8-6	2	7-8	2	9-5	2	8-3	2	7-5	2	8-10	2	7-9	2	7-0	2														
	Roof, ceiling, and two clear-span floors 	2-2 x 4	2-1	1	1-8	1	1-6	2	2-0	1	1-8	1	1-5	2	2-0	1	1-8	1	1-5	2													
2-2 x 6		3-1	2	2-8	2	2-4	2	3-0	2	2-7	2	2-3	2	2-11	2	2-7	2	2-3	2														
2-2 x 8		3-10	2	3-4	2	3-0	3	3-10	2	3-4	2	2-11	3	3-9	2	3-3	2	2-11	3														
2-2 x 10		4-9	2	4-1	3	3-8	3	4-8	2	4-0	3	3-7	3	4-7	3	4-0	3	3-6	3														
2-2 x 12		5-6	3	4-9	3	4-3	3	5-5	3	4-8	3	4-2	3	5-4	3	4-7	3	4-1	4														
3-2 x 8		4-10	2	4-2	2	3-9	2	4-9	2	4-1	2	3-8	2	4-8	2	4-1	2	3-8	2														
3-2 x 10		5-11	2	5-1	2	4-7	3	5-10	2	5-0	2	4-6	3	5-9	2	4-11	2	4-5	3														
3-2 x 12		6-10	2	5-11	3	5-4	3	6-9	2	5-10	3	5-3	3	6-8	2	5-9	3	5-2	3														
4-2 x 8		5-7	2	4-10	2	4-4	2	5-6	2	4-9	2	4-3	2	5-5	2	4-8	2	4-2	2														
4-2 x 10		6-10	2	5-11	2	5-3	2	6-9	2	5-10	2	5-2	2	6-7	2	5-9	2	5-1	2														
4-2 x 12		7-11	2	6-10	2	6-2	3	7-9	2	6-9	2	6-0	3	7-8	2	6-8	2	5-11	3														

For SI: 1 inch = 25.4 mm, 1 pound per square foot = 0.0479 kPa.

- a. Spans are given in feet and inches.
- b. No. 1 or better grade lumber shall be used for southern pine. Other tabulated values assume #2 grade lumber.
- c. Building width is measured perpendicular to the ridge. For widths between those shown, spans are permitted to be interpolated.
- d. NJ = Number of jack studs required to support each end. Where the number of required jack studs equals one, the header is permitted to be supported by an approved framing anchor attached to the full-height wall stud and to the header.
- e. Use 30 psf ground snow load for cases in which ground snow load is less than 30 psf and the roof live load is equal to or less than 20 psf.



**TABLE R602.7(2)**  
**GIRDER SPANS<sup>a</sup> AND HEADER SPANS<sup>a</sup> FOR INTERIOR BEARING WALLS**  
 (Maximum span for Douglas fir-larch, hem-fir, southern pine and spruce-pine-fir<sup>b</sup> and required number of jack studs)

\*\*\*

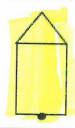
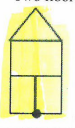
HEADERS AND GIRDERS SUPPORTING	SIZE	BUILDING Width <sup>c</sup> (feet)					
		20		28		36	
		Span	NJ <sup>d</sup>	Span	NJ <sup>d</sup>	Span	NJ <sup>d</sup>
One floor only 	2-2 x 4	3-1	1	2-8	1	2-5	1
	2-2 x 6	4-6	1	3-11	1	3-6	1
	2-2 x 8	5-9	1	5-0	2	4-5	2
	2-2 x 10	7-0	2	6-1	2	5-5	2
	2-2 x 12	8-1	2	7-0	2	6-3	2
	3-2 x 8	7-2	1	6-3	1	5-7	2
	3-2 x 10	8-9	1	7-7	2	6-9	2
	3-2 x 12	10-2	2	8-10	2	7-10	2
	4-2 x 8	9-0	1	7-8	1	6-9	1
	4-2 x 10	10-1	1	8-9	1	7-10	2
Two floors 	2-2 x 4	2-2	1	1-10	1	1-7	1
	2-2 x 6	3-2	2	2-9	2	2-5	2
	2-2 x 8	4-1	2	3-6	2	3-2	2
	2-2 x 10	4-11	2	4-3	2	3-10	3
	2-2 x 12	5-9	2	5-0	3	4-5	3
	3-2 x 8	5-1	2	4-5	2	3-11	2
	3-2 x 10	6-2	2	5-4	2	4-10	2
	3-2 x 12	7-2	2	6-3	2	5-7	3
	4-2 x 8	6-1	1	5-3	2	4-8	2
	4-2 x 10	7-2	2	6-2	2	5-6	2
	4-2 x 12	8-4	2	7-2	2	6-5	2

For SI: 1 inch = 25.4 mm, 1 foot = 304.8 mm.

- a. Spans are given in feet and inches.
- b. No. 1 or better grade lumber shall be used for southern pine. Other tabulated values assume #2 grade lumber.
- c. Building width is measured perpendicular to the ridge. For widths between those shown, spans are permitted to be interpolated.
- d. NJ = Number of jack studs required to support each end. Where the number of required jack studs equals one, the header is permitted to be supported by an approved framing anchor attached to the full-height wall stud and to the header.

**TABLE R602.7(3)**  
**GIRDER AND HEADER SPANS<sup>a</sup> FOR OPEN PORCHES**  
 (Maximum span for Douglas fir-larch, hem-fir, southern pine and spruce-pine-fir<sup>b</sup>)

SIZE	SUPPORTING ROOF						SUPPORTING FLOOR	
	GROUND SNOW LOAD (psf)							
	30		50		70			
	DEPTH OF PORCH <sup>c</sup> (feet)							
	8	14	8	14	8	14		
2-2 x 6	7-6	5-8	6-2	4-8	5-4	4-0	6-4	4-9
2-2 x 8	10-1	7-7	8-3	6-2	7-1	5-4	8-5	6-4
2-2 x 10	12-4	9-4	10-1	7-7	8-9	6-7	10-4	7-9
2-2 x 12	14-4	10-10	11-8	8-10	10-1	7-8	11-11	9-0

For SI: 1 inch = 25.4 mm, 1 foot = 304.8 mm, 1 pound per square foot = 0.0479 kPa.

- a. Spans are given in feet and inches.
- b. Tabulated values assume #2 grade lumber, wet service and incising for refractory species. Use 30 psf ground snow load for cases in which ground snow load is less than 30 psf and the roof live load is equal to or less than 20 psf.
- c. Porch depth is measured horizontally from building face to centerline of the header. For depths between those shown, spans are permitted to be interpolated.

2018 NC Residential Code  
 Table R602.7.5 Minimum Number of Full Height King Studs at Each End of Exterior Walls. (191210 Item B-7)

**TABLE R602.7.5  
 MINIMUM NUMBER OF FULL HEIGHT KING STUDS  
 AT EACH END OF HEADERS IN EXTERIOR WALLS**

HEADER SPAN (feet)	MAXIMUM STUD SPACING (inches) [per Table R602.3(5)]	
	16	24
≤3'	1	1
4'	2	1
8'	3	2
12'	5	3
16'	6	4

<u>HEADER SPAN (feet)</u>	<u>MINIMUM NUMBER OF FULL HEIGHT STUDS (King)</u>
<u>Up to 3'</u>	<u>1</u>
<u>&gt;3' to 6'</u>	<u>2</u>
<u>&gt;6' to 9'</u>	<u>3</u>
<u>&gt;9' to 12'</u>	<u>4</u>
<u>&gt;12' to 15'</u>	<u>5</u>

The delayed effective date of this Rule is January 1, 2021.  
 The Statutory authority for Rule-making is G. S. 143-136; 143-138.

**ERRATA** – corrected jack stud reference in Figure R602.10.1 – Method PF-Portal Frame Construction on page 134.

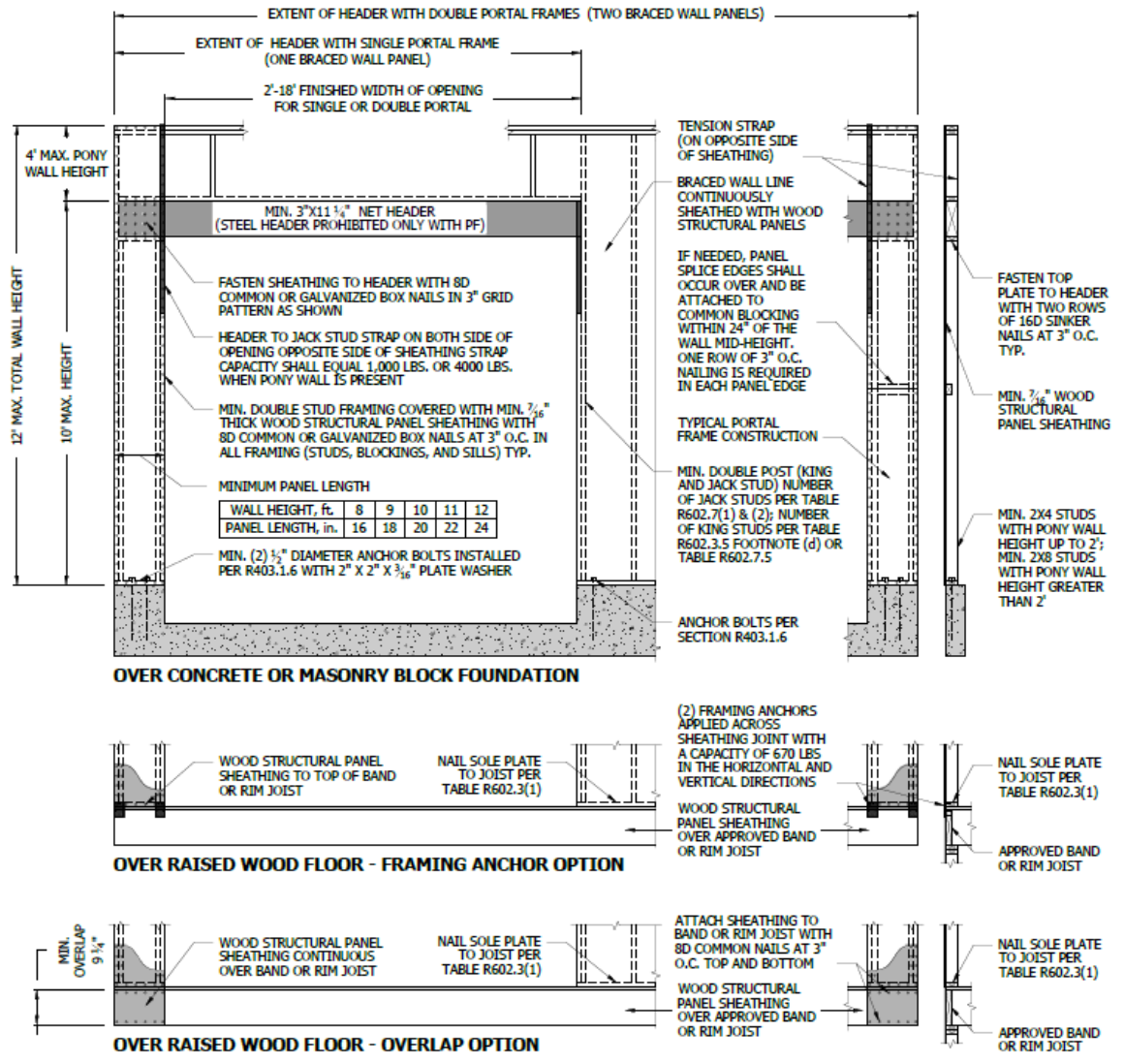

**FIGURE R602.10.1**  
**METHOD PF – PORTAL FRAME CONSTRUCTION**

**TABLE R602.10.1  
 BRACING METHODS<sup>a,b</sup>**

METHOD	MINIMUM BRACE MATERIAL THICKNESS	MINIMUM BRACE PANEL LENGTH OR BRACE ANGLE	CONNECTION CRITERIA		FIGURE OF BRACING METHOD, NOT NECESSARILY LOCATION
			Fasteners	Spacing	
<b>LIB</b> Let-in-bracing	1 x 4 wood brace (or approved metal brace installed per manufacturer instructions)	45° angle for maximum 16" o.c. stud spacing	2-8d common nails or 3-8d (2½" long x 0.113" dia.) nails	Per stud and top and bottom plates	
<b>DWB</b> Diagonal wood boards	¾" (1" nominal)	48"	2-8d (2½" long x 0.113" diameter) or 2 - 1¾"-long-staples	Per stud and top and bottom plates	
<b>WSP</b> Wood Structural panel	3/8"	48" <sup>d</sup>	6d common nail or 8d (2½" long x 0.113" diameter) nail [See Table R602.3(3)]	6" edges 12" field	
<b>SFB</b> Structural fiberboard sheathing	1/2"	48" <sup>d</sup>	1½" long x 0.120" diameter galvanized roofing nails	3" edges 6" field	
<b>GB</b> Gypsum board installed on both sides of wall	1/2"	96" for use with R602.10.2 48" for use with R602.10.3	Minimum 5d cooler nails or #6 screws	7" edges 7" field	
<b>PCP</b> Portland cement plaster	3/4" (maximum 16" o.c. stud spacing)	48"	1½" long, 11 gage, 7/16" diameter head nails or 7/8" long 6 gage staples	6" o.c. on all framing members	
<b>CS-WSP<sup>e,i</sup></b> Continuously Sheathed SFB	3/8"	24" adjacent to window not more than 67% of wall height:	Same as WSP	Same as WSP	
<b>CS-SFB<sup>e,i</sup></b> Continuously sheathed SFB	1/2"	30" adjacent to door or window greater than 67% and less than 85% of wall height. 48" for taller openings.	Same as SFB	Same as SFB	
<b>PF</b> Portal Frame <sup>f,g,h</sup>	7/16"	See Figure R602.10.1	See Figure R602.10.1	See Figure R602.10.1	

**Notes:**

- Alternative bracing materials and methods shall comply with Section 105 of the *North Carolina Administrative Code and Policies*, and shall be permitted to be used as a substitute for any of the bracing materials listed in Table R602.10. 1 provided at least equivalent performance is demonstrated, Where the tested bracing strength or stiffness differs from tabulated materials. the bracing amount required for the alternative material shall be permitted to be factored to achieve equivalence.

- b. All edges of panel-type wall bracing required from Tables Section R602.10.2 and or Section R602.10.3 shall be attached to framing or blocking, except GB bracing horizontal joints shall not be required to be blocked when joints are finished.
- c. Two LIB braces installed at a 60° angle shall be permitted to be substituted for each 45° angle LIB brace.
- d. For 8-foot (2483 mm) or 9-foot (2743 mm) wall height. brace panel minimum length shall be permitted to be reduced to 36-inch (914 mm) or 42-inch length (1067 mm). respectively, where not located adjacent to a door opening. A braced wall panel shall be permitted to be reduced to a 32-inch (813 mm.) length when studs at each end of the braced wall panel are anchored to foundation or framing below using hold-down device with minimum 2,800 pounds design tension capacity, For detached single story garages and attached garages supporting roof only. a minimum 24-inch (610 mm) brace panel length shall be permitted on one wall containing one or more garage door openings.
- e. Bracing methods designated CS-WSP and CS-SFB shall have sheathing installed on all sheathable surfaces above. below, and between wall openings.
- f. For purposes of bracing in accordance with Section R602.10.2. two portal frame brace panels with wood structural panel sheathing applied to the exterior face of each brace panel as shown in Figure R602.10.1 shall be considered equivalent to. one braced wall panel:
- g. Structural fiberboard (SFB) shall not be used in portal frame construction.
- h. No more than three portal frames shall be used in a single building elevation.
- i. CS-WSP and CS-SFB cannot be mixed on the same story. Gable ends shall match the panel type of the wall below.

**Table R602.10.3**  
**REQUIRED LENGTH OF BRACING ALONG EACH SIDE OF A CIRCUMSCRIBED**  
**RECTANGLE<sup>a,b,c,d,e,f,g,h</sup>**

7/16-inch Wood Structural Panel Sheathing with 1/2-inch gypsum on inside wall  
Panels are blocked  
Nails to be 8d common or galvanized box (2-1/2 inches long X 0.113-inch diameter)  
6-inch nail spacing on edges and 6-inch nail spacing in field  
Each story is 10 feet maximum  
Maximum stud spacing of 24 inches  
Maximum roof slope 12:12  
Building length to width ratio is 2

WIND SPEED	EAVE TO RIDGE HEIGHT (feet)	STORIES SUPPORTED	WALL PERPENDICULAR TO WIND (Wall Wind Loads)														
			Building Width in Feet														
			10	15	20	25	30	35	40	45	50	55	60	65	70	75	80
115	10	Roof Only	2.0 1.6	2.0 1.6	2.5 3.2	3.0 2.4	3.5 4.8	4.0 3.0	4.5 6.4	5.0 8.0	5.5 8.0	6.0 9.6	6.5 9.6	7.0 11.2	7.5 11.2	8.0 12.8	
		Roof +1 story	3.0 2.9	4.0 2.9	5.5 5.9	6.5 5.9	8.0 8.8	9.0 8.8	10.0 11.8	11.0 11.8	12.5 14.7	13.5 14.7	14.5 17.7	16.0 17.7	17.0 20.6	18.0 20.6	19.0 23.6
		Roof +2 stories	4.5 4.4	6.5 4.4	8.5 8.8	10.5 8.8	12.0 13.2	14.0 13.2	16.0 17.7	17.5 17.7	19.5 22.1	21.0 22.1	23.0 26.5	24.5 26.5	26.5 30.9	28.5 30.9	30.0 35.3
	15	Roof Only	2.0 1.6	2.0 1.6	3.0 4.0	3.5 2.4	4.0 6.1	4.5 3.0	5.5 8.1	6.0 6.0	6.5 10.1	7.0 10.1	8.0 12.1	8.5 12.1	9.0 14.2	9.5 14.2	10.0 16.2
		Roof +1 story	3.5 3.3	4.5 3.3	6.0 6.6	7.0 6.6	8.5 10.0	9.5 10.0	11.0 13.3	12.0 13.3	13.5 16.6	15.0 16.6	16.0 19.9	17.5 19.9	18.5 23.3	20.0 23.3	21.0 26.6
		Roof +2 stories	5.0 4.8	7.0 4.8	9.0 9.6	11.0 9.6	13.0 14.5	15.0 14.5	16.5 19.3	18.5 19.3	20.5 24.1	22.5 24.1	24.5 28.9	26.0 28.9	28.0 33.8	30.0 33.8	32.0 38.6
	20	Roof Only	2.0 2.4	2.5 2.4	3.5 4.7	4.0 2.4	4.5 7.1	5.5 4.0	6.0 9.4	7.0 7.0	7.5 11.8	8.5 11.8	9.0 14.2	10.0 14.2	10.5 16.5	11.5 16.5	12.0 18.9
		Roof +1 story	3.5 3.7	5.0 3.7	6.5 7.4	8.0 7.4	9.0 11.1	10.5 11.1	12.0 14.8	13.5 14.8	14.5 18.5	16.0 18.5	17.5 22.2	18.5 22.2	20.0 25.9	21.5 25.9	23.0 29.6
		Roof +2 stories	5.0 5.2	7.5 5.2	9.5 10.5	11.5 10.5	13.5 15.7	15.5 15.7	17.5 20.9	19.5 20.9	21.5 26.2	23.5 26.2	25.5 31.4	27.5 31.4	29.5 36.6	31.5 36.6	33.5 41.9
120	10	Roof Only	2.0 1.8	2.0 1.8	2.5 3.7	3.0 2.4	3.5 5.5	4.0 3.0	5.0 7.4	5.5 6.0	6.0 9.2	6.5 11.0	7.0 11.0	7.5 12.9	8.0 12.9	8.5 14.7	

		Roof +1 story	3.5 3.2	4.5	6.0 6.4	7.0	8.5 9.7	9.5	11.0 12.9	12.0	13.5 16.1	14.5	16.0 19.3	17.0	18.5 22.6	19.5	21.0 25.8	
		Roof +2 stories	5.0 4.8	7.0	9.5 9.6	11.5	13.0 14.4	15.0	17.0 19.3	19.0	21.0 24.1	23.0	25.0 28.9	27.0	29.0 33.7	31.0	32.5 38.5	
	15	Roof Only	2.0 2.2	2.5	3.0 4.4	3.5	4.5 6.6	5.0	6.0 8.8	6.5	7.0 11.0	8.0	8.5 13.2	9.0	10.0 15.4	10.5	11.0 17.6	
		Roof +1 story	3.5 3.6	5.0	6.5 7.3	8.0	9.0 10.9	10.5	12.0 14.5	13.5	14.5 18.2	16.0	17.5 21.8	19.0	20.0 25.4	21.5	23.0 29.1	
		Roof +2 stories	5.5 5.3	7.5	10.0 10.5	12.0	14.0 15.8	16.0	18.0 21.0	20.0	22.5 26.3	24.5	26.5 31.6	28.5	30.5 36.8	32.5	34.5 42.1	
	20	Roof Only	2.0 2.6	3.0	3.5 5.1	4.5	5.0 7.7	6.0	6.5 10.3	7.5	8.5 12.8	9.0	10.0 15.4	10.5	11.5 18.0	12.5	13.0 20.5	
		Roof +1 story	4.0	5.5	7.0 8.1	8.5	10.0 12.1	11.5	13.0 16.2	14.5	16.0 20.2	17.5	19.0 24.3	20.5	22.0 28.3	23.5	25.0 32.4	
		Roof +2 stories	5.5 5.7	8.0	10.5 11.4	12.5	14.5 17.1	17.0	19.0 22.8	21.5	23.5 28.5	25.5	28.0 34.2	30.0	32.0 39.9	34.5	36.0 45.6	
	130	10	Roof Only	2.0 2.2	2.5	3.0 4.3	3.5	4.5 6.5	5.0	5.5 8.6	6.5	7.0 10.8	7.5	8.0 12.9	9.0	9.5 15.1	10.0	11.0 17.3
			Roof +1 story	4.0 3.8	5.5	7.0 7.6	8.5	10.0 11.4	11.5	13.0 15.1	14.5	16.0 18.9	17.5	18.5 22.7	20.0	21.5 26.5	23.0	24.5 30.3
			Roof +2 stories	6.0 5.7	8.5	11.0 11.4	13.0	15.5 17.0	18.0	20.0 22.7	22.5	24.5 28.4	27.0	29.5 34.1	31.5	34.0 39.8	36.0	38.5 45.5
		15	Roof Only	2.0 2.6	3.0	3.5 5.2	4.5	5.0 7.7	6.0	7.0 10.3	7.5	8.5 12.9	9.0	10.0 15.5	10.5	11.5 18.1	12.5	13.0 20.7
Roof +1 story			4.0 4.3	6.0	7.5 8.5	9.0	11.0 12.8	12.5	14.0 17.1	15.5	17.0 21.3	19.0	20.5 25.6	22.0	23.5 29.9	25.5	27.0 34.1	
Roof +2 stories			6.0 6.2	9.0	11.5 12.4	14.0	16.5 18.6	19.0	21.5 24.8	23.5	26.0 31.0	28.5	31.0 37.2	33.5	36.0 43.4	38.0	40.5 49.7	
20		Roof Only	2.5 3.0	3.5	4.5 6.0	5.0	6.0 9.0	7.0	8.0 12.0	9.0	10.0 15.1	10.5	11.5 18.1	12.5	13.5 21.1	14.5	15.5 24.1	
		Roof +1 story	4.5 4.7	6.5	8.0 9.5	10.0	11.5 14.2	13.5	15.0 19.0	17.0	18.5 23.7	20.5	22.0 28.5	24.0	25.5 33.2	27.5	29.0 38.0	
		Roof +2 stories	6.5 6.7	9.5	12.0 13.5	14.5	17.5 20.2	20.0	22.5 26.9	25.0	27.5 33.7	30.0	32.5 40.4	35.5	38.0 47.1	40.5	43.0 53.8	

a. If the stud spacing is reduced to 16 inches, table values for 7/16-inch sheathing may be multiplied by 0.93.

b. If the stud spacing is reduced to 16 inches or the sheathing thickness is greater than 7/16-inch, the interior field nail spacing may be increased to 12 inches.

c. If the 1/2-inch gypsum is not applied to the inside of the wall, the table lengths are to be multiplied by 1.22.

d. Table values shall be multiplied by the following values for different wall heights:

8ft. walls 0.87

9ft. walls 0.92

11ft. walls 1.08

12ft. walls 1.15

e. If 3/8-inch wood structural sheathing is used instead of 7/16-inch wood structural sheathing, table lengths are to be multiplied by 1.07.

f. If 1/2-inch structural fiberboard is used instead of 7/16-inch wood structural sheathing, table lengths are to be multiplied by 1.31.

g. Interpolation is permitted, extrapolation is prohibited.

h. For Exposure Category C or D, multiply the required length of bracing by a factor of 1.5 or 1.8 respectively.



Roof Only

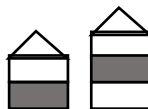

Roof + 1 Story



Roof + 2 Stories

a. Interpolation shall be permitted; extrapolation shall be prohibited.

b. For Exposure Category C or D, multiply the required length of bracing by a factor of 1.3 or 1.6, respectively.

c. For wall heights other than 10 feet (3048 mm), multiply the required length of bracing by the following factors; 0.90 for 8 feet (2438mm), 0.95 for 9 feet (2743 mm), 1.05 for 11 feet (3353) and 1.10 for 12 feet (3658 mm).

d. Where minimum 1/2 inch gypsum wall board interior finish is not provided, the required bracing amount for the affected rectangle side shall be multiplied by 1.40.

~~e. A floor, habitable or otherwise, contained wholly within the roof rafters or roof trusses need not be considered a story for purposes of determining wall bracing provided the eave to ridge height does not exceed 20 feet (6096 mm) and the openings in the roof do not exceed 48 inches (1219 mm) in width.~~  
~~f. Perpendicular sides to the front and rear sides are the left and right sides. Perpendicular sides to the left and right sides are the front and rear sides.~~

The delayed effective date of this Rule is January 1, 2021.

The Statutory authority for Rule-making is G. S. 143-136; 143-138.

**R703.8.2.1 Support by steel angle.** A minimum 6-inch by 4-inch by 5/16-inch (152 mm by 102 mm by 8 mm) steel angle, with the long leg placed vertically, shall be anchored to double 2-inch by 4-inch (51 mm by 102 mm) wood studs at a maximum on-center spacing of 16 inches (406 mm). Anchorage of the steel angle at every double stud spacing shall be a minimum of not less than two 7/16-inch diameter (11 mm) by 4-inch (102 mm) lag screws for wood construction at every double stud or shall be a minimum of two 7/16-inch diameter (11.1 mm) by 4 inches (102 mm) lag screws into solid double blocking with each pair of lag screws spaced at horizontal intervals not to exceed 16 inches (406 mm). The steel angle shall have a minimum clearance to underlying construction of 1/16 inch (1.6 mm). ~~Not less than~~ A minimum of two-thirds the width of the masonry veneer thickness shall bear on the steel angle. Flashing and weep holes shall be located in the masonry veneer in accordance with Figure R703.8.2.1. The maximum height of masonry veneer above the steel angle support shall be 12 feet 8 inches (3861 mm). The airspace separating the masonry veneer from the wood backing shall be in accordance with Sections R703.8.4 and R703.8.4.2. The method of support for the masonry veneer on ~~wood construction~~ steel angle shall be constructed in accordance with Figure R703.8.2.1.

The maximum slope of the roof construction without stops shall be 7:12. Roof construction with slopes greater than 7:12 but not more than 12:12 shall have stops of a minimum 3-inch by 3-inch by 1/4-inch (76 mm by 76 mm by 6.4 mm) steel plate welded to the angle at 24 inches (610 mm) on center along the angle or as *approved* by the *building official*.



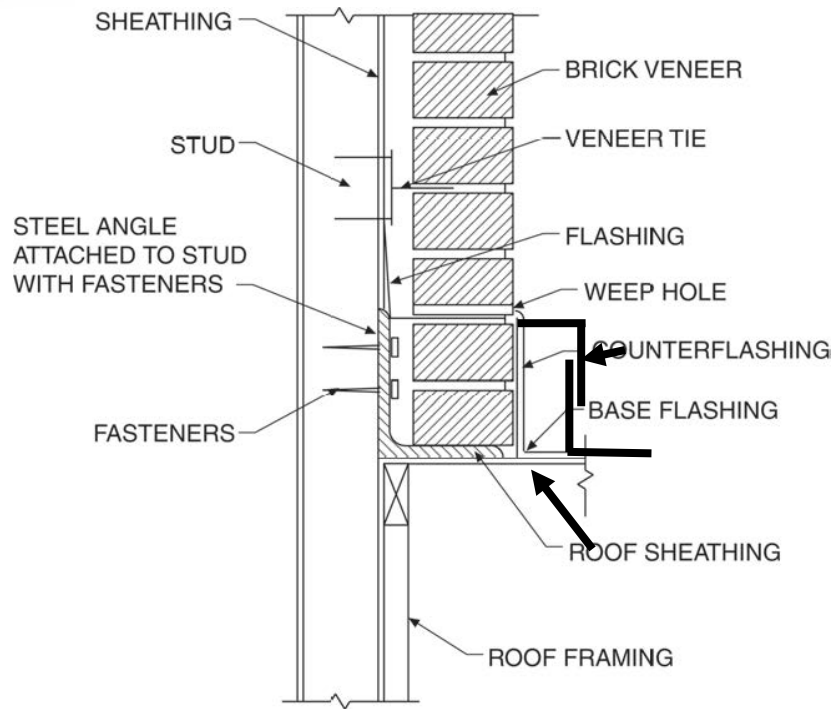
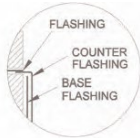

SUPPORT BY STEEL ANGLE

**FIGURE R703.8.2.1**  
**EXTERIOR MASONRY VENEER SUPPORT BY STEEL ANGLES**

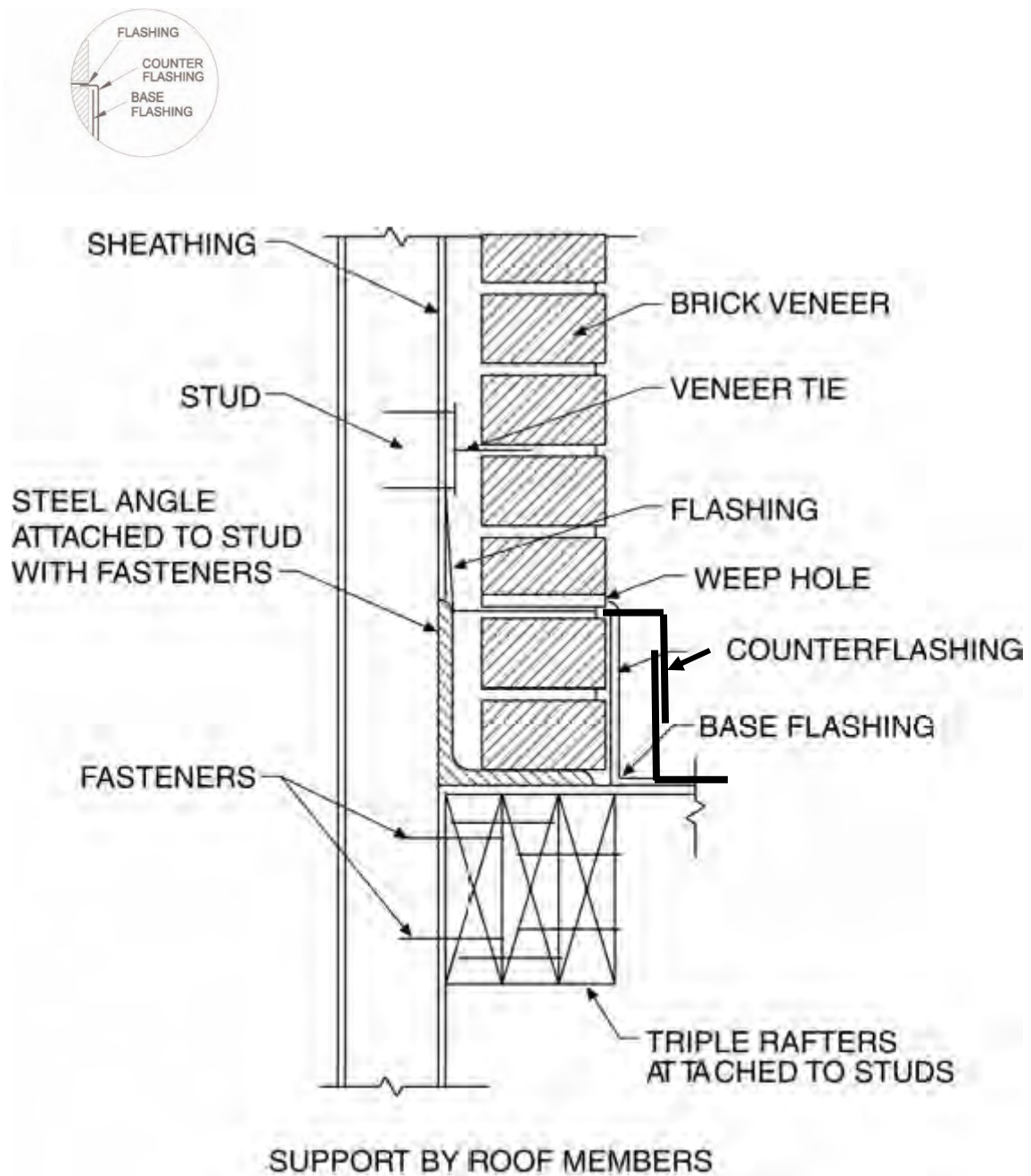

**FIGURE R703.8.2.2  
EXTERIOR MASONRY VENEER SUPPORT BY ROOF MEMBER**

The delayed effective date of this Rule is January 1, 2021.  
The Statutory authority for Rule-making is G. S. 143-136; 143-138.

2018 NC Residential Code

R703.8.2.1 Support by steel angle. (190312 Item B-17)

**R703.8.2.1 Support by steel angle.** A minimum 6-inch by 4-inch by  $\frac{5}{16}$ -inch (152 mm by 102 mm by 8 mm) steel angle, with the long leg placed vertically, shall be anchored to double 2-inch by 4-inch (51 mm by 102 mm) wood studs at a maximum on-center spacing of 16 inches (406 mm) or shall be anchored to solid double 2x blocking firmly attached between single 2-inch by 4-inch (51 mm by 102 mm) wood studs at a maximum on center spacing of 16 inches (406 mm). Anchorage of the steel angle at every double stud spacing shall be not less than two  $\frac{7}{16}$ -inch-diameter (11 mm) by 4-inch (102 mm) lag screws for wood construction. The steel angle shall have a minimum clearance to underlying construction of  $\frac{1}{16}$  inch (1.6 mm). Not less than two-thirds the width of the masonry veneer thickness shall bear on the steel angle. Flashing and weep holes shall be located in the masonry veneer in accordance with Figure R703.8.2.1. The maximum height of masonry veneer above the steel angle support shall be 12 feet 8 inches (3861 mm). The airspace separating the masonry veneer from the wood backing shall be in accordance with Sections R703.8.4 and R703.8.4.2. The method of support for the masonry veneer on wood construction shall be constructed in accordance with Figure R703.8.2.1

The maximum slope of the roof construction without stops shall be 7:12. Roof construction with slopes greater than 7:12 but not more than 12:12 shall have stops of a minimum 3-inch by 3-inch by  $\frac{1}{4}$ -inch (76 mm by 76 mm by 6.4 mm) steel plate welded to the angle at 24 inches (610 mm) on center along the angle or as *approved* by the *building official*.

The delayed effective date of this Rule is January 1, 2021.

The Statutory authority for Rule-making is G. S. 143-136; 143-138.

June 14, 2022

2018 NC Residential Code

R905.2.8.5 Drip edge and R908.3 Roof replacement (200714 Item B-24)

**R905.2.8.5 Drip Edge.** ~~Deleted.~~ Not required unless required by the roof covering manufacturer installation instructions. The drip edge placed around the edge of a roof prior to installing the roofing material shall be designed so that water runs off over the drip edge and falls from a slight projection at the bottom edge of the roof rather than running back under, or along the eaves. Metal, wood or exterior composite materials can be used for the drip edge.

**R908.3 Roof replacement.** Roof replacement shall include the removal of existing layers of roof coverings down to the roof deck and replacement of up to 15% of the total existing roof deck. Replacement of up to 15% of the total roof deck shall not be considered structural work.

The delayed effective date of this Rule is January 1, 2022.

The Statutory authority for Rule-making is G. S. 143-136; 143-138.

June 14, 2022

2018 NC Residential Code  
N1101.1 Scope. (180911 Item B-17)

**N1101.1 Scope.**

This chapter regulates the energy efficiency for the design and construction of buildings regulated by this code.

**Exception:**

1. In accordance with N.C.G.S. 143-138 (b19), no energy conservation code provisions shall apply to detached and attached garages located on the same lot as a dwelling.

The delayed effective date of this Rule is January 1, 2020.  
The Statutory authority for Rule-making is G. S. 143-136; 143-138.

2018 NC Residential Code  
N1101.13 Compliance. (200901 Item B-5)

**N1101.13 (R401.2) Compliance.**

Projects shall comply with one of the following:

1. Section N1101.14 through N1104.
2. Section N1105 and the provisions of Section N1101.14 labeled “Mandatory.”
3. An energy rating index (ERI) approach in Section N1106.
4. ~~North Carolina specific~~ REScheck keyed to the 2018 IECC shall be permitted to demonstrate compliance with this Code. Envelope requirements may not be traded off against the use of high efficiency heating or cooling equipment. No tradeoff calculations are needed for required termite inspection and treatment gaps.

The delayed effective date of this Rule is January 1, 2022.  
The Statutory authority for Rule-making is G. S. 143-136; 143-138.

June 14, 2022

2018 NC Residential Code  
N1102.1.2, N1102.1.4, R&U-Value Tables. (170613 Item B-13)

**The Agency withdrew this item due to RRC February 15, 2018 objection.**  
The Statutory authority for Rule-making is G. S. 143-136; 143-138.

2018 NC Residential Code  
N1106 Energy Rating Index. (161213 Item B-3.4)

## **SECTION N1106 ENERGY RATING INDEX COMPLIANCE ALTERNATIVE**

**N1106.1 Scope.** This section establishes criteria for compliance using an Energy Rating Index (ERI) analysis.

### **N1106.2 Mandatory requirements.**

Compliance with this section requires that the ~~mandatory~~ provisions identified in Sections ~~N1101.2~~ N1101 through N1104 labeled as “mandatory” and ~~Section N1103.5.3~~ be met. The building thermal envelope shall be greater than or equal to levels of efficiency and Solar Heat Gain Coefficient in Table 1102.1.1 or 1102.1.3 of the ~~2009 International Energy Conservation Code~~ 2012 NC Energy Conservation Code. Minimum standards associated with compliance shall be the ANSI RESNET ICC Standard 301-2014 “Standard for the Calculation and Labeling of the Energy Performance of Low-Rise Residential Buildings using an Energy Rating Index.” A North Carolina *licensed design professional* or certified HERS rater is required to perform the analysis if required by North Carolina licensure laws.

**Exception:** ~~Supply and return ducts not completely inside the building thermal envelope shall be insulated to a minimum of R-6. Supply and return ducts in unconditioned space and outdoors shall be insulated to a minimum R-8. Supply ducts inside semi-conditioned space shall be insulated to a minimum R-4; return ducts inside conditioned and semi-conditioned space are not required to be insulated. Ducts located inside conditioned space are not required to be insulated other than as may be necessary for preventing the formation of condensation on the exterior of cooling ducts.~~

### **N1106.5 Verification by approved agency.**

Verification of compliance with Section N1106 shall be performed by the licensed design professional or certified HERS rater and the compliance documentation shall be provided to the code official. The code official shall inspect according to the requirements of Section N1106.6.2 ~~completed by an approved third party.~~

The delayed effective date of this Rule is January 1, 2019.  
The Statutory authority for Rule-making is G. S. 143-136; 143-138.

(Note: All other strikethroughs/underlines are part of the 2018 Code adoption package.)  
(Note: certified HERS rater = RESNET Certified Home Energy Rater)



**N1106.2 Mandatory requirements.** Compliance with this section requires that the provisions identified in Sections N1101 through N1104 labeled as “mandatory” be met. The building thermal envelope shall be greater than or equal to levels of efficiency and Solar Heat Gain Coefficient in Table N1106.2.1 or Table N1106.2.2, Table 402.2.3 or 402.1.3 of the 2012 North Carolina Energy Conservation Code. Minimum standards associated with compliance shall be the ANSI RESNET ICC Standard 301-2014: “Standard for the Calculation and Labeling of the Energy Performance of Low-Rise Residential Buildings using an Energy Rating Index.” A North Carolina *registered design professional* or certified *HERS rater* is required to perform the analysis if required by North Carolina licensure laws.

**Exception:** Supply and return ducts in unconditioned space and outdoors shall be insulated to a minimum R-8. Supply ducts inside semi-conditioned space shall be insulated to a minimum R-4; return ducts inside conditioned and semi-conditioned space are not required to be insulated. Ducts located inside conditioned space are not required to be insulated other than as may be necessary for preventing the formation of condensation on the exterior of cooling ducts.

**TABLE N1106.2.1  
 MINIMUM INSULATION AND FENESTRATION REQUIREMENTS FOR ENERGY RATING  
 INDEX COMPLIANCE<sup>a</sup>**

CLIMATE ZONE	FENESTRATION VALUES			R-VALUES FOR								
	FENESTRATION U-FACTOR <sup>b,j</sup>	SKYLIGHT <sup>b</sup> U-FACTOR	GLAZED FENESTRATION SHGC <sup>b,k</sup>	CEILING <sup>m</sup>	UNVENTED <sup>p</sup> RAFTER ASSEMBLIES IN ATTICS CONTAINING DUCTWORK, AIR-IMPERMEABLE	UNVENTED <sup>p</sup> RAFTER ASSEMBLIES IN ATTICS CONTAINING DUCTWORK, AIR-PERMIABLE/ IMPERMEABLE	WOOD FRAME WALL	MASS WALL <sup>l</sup>	FLOOR	BASEMENT <sup>c,o</sup> WALL	SLAB <sup>d</sup>	CRAWL SPACE <sup>c</sup> WALL
3	0.35	0.65	0.3	30	20	15-10 <sup>q</sup>	13	5/10	19	10/13 <sup>f</sup>	0	5/13
4	0.35	0.6	0.3	38 or 30ci <sup>i</sup>	20	15-10 <sup>q</sup>	15, 13+2.5 <sup>h</sup>	5/10	19	10/13	10	10/13
5	0.35	0.6	NR	38 or 30ci <sup>i</sup>	25	15-20 <sup>q</sup>	19 <sup>n</sup> , 13+5 <sup>h</sup> , or 15+3 <sup>h</sup>	13/17	30 <sup>g</sup>	10/13	10	10/13

For SI: 1 foot = 304.8 mm.

a. R-values are minimums. U-factors and SHGC are maximums.

b. The fenestration U-factor column excludes skylights. The SHGC column applies to all glazed fenestration.

c. “10/13” means R-10 continuous insulated sheathing on the interior or exterior of the home or R-13 cavity insulation at the interior of the basement wall or crawl space wall.

d. For monolithic slabs, insulation shall be applied from the inspection gap downward to the bottom of the footing or a maximum of 18 inches below grade, whichever is less. For floating slabs, insulation shall extend to the bottom of the foundation wall or 24 inches, whichever is less. (See Appendix O) R-5 shall be added to the required slab edge R-values for heated slabs.

e.- Deleted.

f. Basement wall insulation is not required in warm-humid locations as defined by Figure N1101.7 and Table N1101.7.

g. Or insulation sufficient to fill the framing cavity, R-19 minimum.

h. The first value is cavity insulation, the second value is continuous insulation so “13+5” means R-13 cavity insulation plus R-5 continuous insulation. If structural sheathing covers 25 percent or less of the exterior, insulating sheathing is not required where structural sheathing is used. If structural sheathing covers more than 25 percent of exterior, structural sheathing shall be supplemented with insulated sheathing of at least R-2.

i. The second R-value applies when more than half the insulation is on the interior of the mass wall.

- j. In addition to the exemption in N1102.3.3, a maximum of two glazed fenestration product assemblies having a U-factor no greater than 0.55 shall be permitted to be substituted for minimum code compliant fenestration product assemblies without penalty.
- k. In addition to the exemption in N1102.3.3, a maximum of two glazed fenestration product assemblies having a SHGC no greater than 0.70 shall be permitted to be substituted for minimum code compliant fenestration product assemblies without penalty.
- l. R-30 shall be deemed to satisfy the ceiling insulation requirement wherever the full height of uncompressed R-30 insulation extends over the wall top plate at the eaves. Otherwise, R-38 insulation is required where adequate clearance exists or insulation must extend either to the insulation baffle or within 1" of the attic roof deck.
- m. Table value required except for roof edge where the space is limited by the pitch of the roof; there the insulation must fill the space up to the air baffle.
- n. R -19 fiberglass batts compressed and installed in a nominal 2 × 6 framing cavity is deemed to comply. Fiberglass batts rated R-19 or higher compressed and installed in a 2x4 wall are not deemed to comply.
- o. Basement wall meeting the minimum mass wall specific heat content requirement may use the mass wall R-value as the minimum requirement.
- p. The air-impermeable insulation shall meet the requirements of the definition in Section R202. Air-impermeable insulation shall be installed in direct contact with the underside of the structural roof sheathing. For one- and two-family dwellings and townhouses, the insulation installation shall meet the requirements of R806.5 of the North Carolina Residential Code. For Residential Buildings other than one- and two-family dwellings and townhouses, the insulation installation shall meet the installation requirements of 1203.3 of the North Carolina Building Code. Exposed rafters shall be covered with R-7 insulation.
- q. The value for air-permeable insulation is shown first and that for air-impermeable insulation second. Thus, R-15 + R-10 indicates that the minimum value for air-permeable insulation is R-15, and the minimum value for air-impermeable insulation is R-10. Air-impermeable insulation shall be installed in direct contact with the underside of the structural roof sheathing. The air-permeable insulation shall be installed directly under the air-impermeable insulation. Exposed rafters shall be covered with R-7 insulation.

**TABLE N1106.2.2**  
**EQUIVALENT U-FACTORS FOR TABLE N1106.2.1<sup>a</sup>**

CLIMATE ZONE	FENESTRATION <sup>d</sup>	SKYLIGHT U-FACTOR	CEILING	UNVENTED <sup>e</sup> RAFTER ASSEMBLIES IN ATTICS CONTAINING DUCTWORK, AIR-IMPERMEABLE	UNVENTED <sup>e</sup> RAFTER ASSEMBLIES IN ATTICS CONTAINING DUCTWORK, AIR-PERMEABLE/IMPERMEABLE	FRAME WALL	MASS WALL <sup>b</sup>	FLOOR	BASE-MENT <sup>d</sup> WALL	CRAWL SPACE <sup>c</sup> WALL
3	0.35	0.65	0.0350	0.05	0.043 <sup>f</sup>	0.082	0.141	0.047	0.059	0.136
4	0.35	0.60	0.0300	0.05	0.043 <sup>f</sup>	0.077	0.141	0.047	0.059	0.065
5	0.35	0.60	0.0300	0.037	0.034 <sup>f</sup>	0.061	0.082	0.033	0.059	0.065

- a. Nonfenestration U-factors shall be obtained from measurement, calculation or an approved source.
- b. When more than half the insulation is on the interior, the mass wall U-factors shall be a maximum of 0.07 in Climate Zone 3, 0.07 in Climate Zone 4 and 0.054 in Climate Zone 5.
- c. Basement wall U-factor of 0.360 in warm-humid locations as defined by Figure N1101.7 and Table N1101.7.
- d. A maximum of two glazed fenestration product assemblies having a U-factor no greater than 0.55 and a SHGC no greater than 0.70 shall be permitted to be substituted for minimum code compliant fenestration product assemblies without penalty. When applying this note and using the RESCheck "UA Trade-off" compliance method to allow continued use of the software, the applicable fenestration products shall be modeled as meeting the U-factor of 0.35 and the SHGC of 0.30, as applicable, but the fenestration products' actual U-factor and actual SHGC shall be noted in the comments section of the software for documentation of application of this note to the applicable products. Compliance for these substitute products shall be verified compared to the allowed substituted maximum U-value requirement and maximum SHGC requirement, as applicable.

e. The air-impermeable insulation shall meet the requirements of the definition in section R202. Air-impermeable insulation shall be installed in direct contact with the underside of the structural roof sheathing. For one- and two-family dwellings and townhouses, the insulation installation shall meet the requirements of R806.5 of the North Carolina Residential Code. Exposed rafters shall be covered with R-7 insulation.

f. For air-permeable/ impermeable applications, Table N1106.2.1 shall be followed for minimum insulation values.

The delayed effective date of this Rule is January 1, 2022.

The Statutory authority for Rule-making is G. S. 143-136; 143-138.

2018 NC Residential Code  
M1402.1 General. (200901 Item B-9)

**M1402.1 (918.1) General.** Oil-fired central furnaces shall conform to ANSI/UL 727. Electric furnaces shall conform to UL 1995 or UL/CSA 60335-2-40. Solid fuel furnaces shall be tested in accordance with UL 391.

The delayed effective date of this Rule is January 1, 2022.  
The Statutory authority for Rule-making is G. S. 143-136; 143-138.

June 14, 2022

2018 NC Residential Code  
M1403.1 Heat pumps. (200901 Item B-10)

**M1403.1 (918.2) Heat pumps.** Electric heat pumps shall be listed and labeled in accordance with UL 1995 or UL/CSA/~~ANCE~~ 60335-2-40.

The delayed effective date of this Rule is January 1, 2022.  
The Statutory authority for Rule-making is G. S. 143-136; 143-138.

June 14, 2022

2018 NC Residential Code

M1411.3.2 Drain pipe materials and sizes. (190611 Item B-2)

**M1411.3.2 Drain pipe materials and sizes.** Components of the condensate disposal system shall be ABS, cast iron, copper, cross-linked polyethylene, CPVC, galvanized steel, PE-RT, polyethylene, polypropylene or PVC pipe or tubing. Components shall be selected for the pressure and temperature rating of the installation. Joints and connections shall be made in accordance with the applicable provisions of Chapter 30. Condensate waste and drain line size shall be not less than 3/4 -inch (19 mm) nominal diameter from the drain pan connection to the place of condensate disposal. Where the drain pipes from more than one unit are manifolded together for condensate drainage, the pipe or tubing shall be sized in accordance with an approved method.

Provisions shall be made to prevent the formation of condensation on the exterior of primary condensate drain piping if condensate dripping off the pipe could cause damage to any building component.

The delayed effective date of this Rule is January 1, 2021.

The Statutory authority for Rule-making is G. S. 143-136; 143-138.

June 14, 2022

2018 NC Residential Code  
M1502.1 General. (190611 Item B-3)

**M1502.1 General.** Clothes dryers shall be exhausted in accordance with the manufacturer's instructions.

**M1502.1.1 (504.6) Makeup air.**

Where a closet is designed for the installation of a clothes dryer, an opening having an area of not less than 100 square inches (0.0645 m<sup>2</sup>) shall be provided in the closet enclosure or *makeup air* shall be provided by other *approved means*.

The delayed effective date of this Rule is January 1, 2021.  
The Statutory authority for Rule-making is G. S. 143-136; 143-138.

2018 NC Residential Code  
M1502.4.2 Duct installation. (190611 Item B-4)

**M1502.4.2 Duct installation.** Exhaust ducts shall be supported at intervals not to exceed ~~42~~ 4 feet (3658 mm) and shall be secured in place. The insert end of the duct shall extend into the adjoining duct or fitting in the direction of airflow. Exhaust duct joints shall be sealed in accordance with Section M1601.4.1 and shall be mechanically fastened. Ducts shall not be joined with screws or similar fasteners that protrude into the inside of the duct. Ducts shall be sealed in accordance with Section M1601.4.1.

- a. Nonmetallic mechanical fasteners (tie-straps) shall be listed to UL 181B.
- b. Metal band duct clamps are not required to be listed.

The delayed effective date of this Rule is January 1, 2021.  
The Statutory authority for Rule-making is G. S. 143-136; 143-138.



2018 NC Residential Code

M1602.3 (603.18) Return-air intake (nonengineered systems). (190611 Item B-5)

**M1602.3 (603.18) Return-air intake (nonengineered systems).** If only one central return-air grille is installed, it shall be of a size sufficient to return a volume of air compatible with the CFM requirements and the temperature rise limitations specified by the equipment manufacturer. The face velocity of return air grilles shall not exceed 450 feet per minute (fpm) (2.3 m/s). At least one separate return shall be installed on each level of a multi-level structure. For split-level and split-foyer structures, one return may serve more than one level if located within the split area and the total area of the levels does not exceed 1,600 square feet (148.6 m<sup>2</sup>). Return-air grilles shall not be located in bathrooms. The return air from one residential living unit shall not be mixed with the return air from other living units.

In dwellings with 1,600 square feet (148.6m<sup>2</sup>) or less of conditioned area, a central return is permitted. When the dwelling contains more than 1,600 square feet (148.6m<sup>2</sup>) of conditioned area, additional returns shall be provided. Each return shall serve not more than 1,600 square feet (148.6 m<sup>2</sup>) of area and shall be located in the area it serves. Return air may travel through the living space to the return-air intake if there are no restrictions, such as solid doors, to the air movement. Undercut doors are allowed. When panned joists are used for return air, the structural integrity shall be maintained. Air capacity for joists 16 inches (406 mm) on center shall be a maximum of 375 cubic feet per minute (0.177 m<sup>3</sup>/s) for 8-inch (203 mm) joists and 525 cubic feet per minute (0.248 m<sup>3</sup>/s) for 10-inch (254 mm) joists. Wiring located in spaces used for return-air ducts shall comply with the *North Carolina Electrical Code*.

The delayed effective date of this Rule is January 1, 2021.

The Statutory authority for Rule-making is G. S. 143-136; 143-138.

June 14, 2022

2018 NC Residential Code

**ERRATA** – remove “or pan” from P2503.6 heading as shown below

**P2503.6 Shower liner test.** (no change to the section requirements)

2018 NC Residential Code  
P2603.5 Freezing. (190312 Item B-21)

**P2603.5 Freezing.** Water pipes installed in a wall exposed to the exterior shall be located on the heated side of the wall insulation. In other cases, water, ~~soil~~ and condensate waste pipes shall not be installed outside of a building, in unconditioned attics, unconditioned utility rooms or in any other place subjected to freezing temperatures unless adequate provision is made to protect such pipes from freezing by a minimum of R-6.5 insulation determined at 75°F (24°C) in accordance with ASTM C177 or heat or both.

Exterior water supply system piping shall be installed ~~not less than 6 inches (152 mm)~~ below the frost line and not less than 12 inches (305 mm) below grade.

**Note:** These provisions are minimum requirements, which have been found suitable for normal weather conditions. Abnormally low temperatures for extended periods may require additional provisions to prevent freezing.

The delayed effective date of this Rule is January 1, 2021.  
The Statutory authority for Rule-making is G. S. 143-136; 143-138.

June 14, 2022

2018 NC Residential Code  
P2603.5.2 Frost protection. (190611 Item B-8)

**P2603.5.2 Frost protection.** No traps of soil or waste pipe shall be installed or permitted outside of a building or concealed in outside walls or in any place where they may be subjected to freezing temperatures, unless *approved* provisions are made to protect them from freezing.

The delayed effective date of this Rule is January 1, 2021.  
The Statutory authority for Rule-making is G. S. 143-136; 143-138.

June 14, 2022

2018 NC Residential Code  
P2604.1.4 Tracer wire. (190312 Item B-20)

**P2604.1.4 Tracer wire.** For plastic sewer *pip*ing, an insulated copper tracer wire or other *approved* conductor shall be installed adjacent to and over the full length of the *pip*ing. Access shall be provided to the tracer wire or the tracer wire shall terminate at the cleanout between the building drain and building sewer. The tracer wire shall be not less than 14 AWG and the insulation type shall be listed for direct burial.

The delayed effective date of this Rule is January 1, 2021.  
The Statutory authority for Rule-making is G. S. 143-136; 143-138.

2018 NC Residential Code – page 503

**ERRATA** – change Section reference to P2906.4.1

**P3002.2.1 (703.1) Building sewer pipe near the water service.** The proximity of a *building sewer* to a water service shall comply with Section P2906.4.1.

2018 NC Residential Code – page 515

**ERRATA** – change Section reference to P3110

**P3101.2.1 (901.2.1) Venting required.** Every *trap* and trapped fixture shall be vented in accordance with one of the venting methods specified in this chapter. All fixtures discharging downstream from a water closet shall be individually vented except as provided in Section P3110.

2018 NC Residential Code – page 517

**ERRATA** – change Section references to P3104.2 and P3102.5

**P3109.3 (913.3) Stack vent.** A stack vent shall be installed for the waste stack. The size of the stack vent shall be not less than the size of the waste stack. Offsets shall be permitted in the stack vent and shall be located not less than 6 inches (152 mm) above the flood level of the highest fixture and shall be in accordance with Section P3104.2. The stack vent shall be permitted to connect with other stack vents and vent stacks in accordance with Section P3102.5.

2018 NC Residential Code  
P2603.5.2 Frost protection. (190611 Item B-8)

**P3201.3 (1002.7) Trap setting and protection.** Traps shall be set level with respect to their water seals and shall be protected from freezing. Trap seals shall be protected from siphonage, aspiration or back pressure by an *approved* system of venting (see Sections P3101 and P2603.5.2).

The delayed effective date of this Rule is January 1, 2021.  
The Statutory authority for Rule-making is G. S. 143-136; 143-138.

June 14, 2022

**ERRATA** – Section P2708.2 (417.3) requires 2” minimum trap as shown below.

**TABLE P3201.7  
SIZE OF TRAPS FOR PLUMBING FIXTURES**

PLUMBING FIXTURE	TRAP SIZE MINIMUM (inches)
Bathtub (with or without shower head and/or whirlpool attachments)	1½
Bidet	1¼
Clothes washer standpipe	2
Dishwasher (on separate trap)	1½
Floor drain	2
Kitchen sink (one or two traps, with or without dishwasher and food waste disposer)	1½
Laundry tub (one or more compartments)	1½
Lavatory	1¼
Shower (based on the total flow rate through showerheads and bodysprays) Flow rate: 5.7 gpm and less More than 5.7 gpm up to 12.3 gpm More than 12.3 gpm up to 25.8 gpm More than 25.8 gpm up to 55.6 gpm	<del>1½</del> 2 2 3 4



2018 NC Residential Code – page 521

**ERRATA** – change Section reference to P2706.1.2 in Exception #3.

**P3201.6 (1002.1) Number of fixtures per trap.**

**Exceptions:**

3. Connection of a laundry tray waste line into a standpipe for the automatic clothes-washer drain shall be permitted in accordance with Section **P2706.1.2**.

2018 NC Residential Code  
Chapter 44 References UL/CSA/ANCE 60335-2-40 & ASHRAE 34. (200901 Item B-8)

**ANCE**

~~UL/CSA/ANCE 60335-2-40-2012~~ ~~Standard for Household and Similar Electrical Appliances,  
Part 2: Particular Requirements for Motor compressors~~  
M1403.1

**ASHRAE**

~~34-2013~~2019 Designation and Safety Classification of Refrigerants  
M1411.1

**CSA**

CSA C22.2 No. 60335-2-40-2019  
~~UL/CSA/ANCE 60335-2-40-2012~~ Standard for Household and Similar Electrical Appliances,  
Part 2-40: Particular Requirements for ~~Motor compressors~~  
Electrical Heat Pumps, Air-Conditioners and Dehumidifiers -  
3<sup>rd</sup> Edition M1402.1, M1403.1

**UL**

1995—~~2014~~2015 Heating and Cooling Equipment  
M1402.1, M1403.1, M1407.1  
~~UL/CSA/ANCE 60335-2-40-2012~~2019 Standard for Household and Similar Electrical Appliances,  
Part 2-40: Particular Requirements for ~~Motor compressors~~  
Electrical Heat Pumps, Air-Conditioners and Dehumidifiers –  
3<sup>rd</sup> Edition  
M1402.1, M1403.1

The delayed effective date of this Rule is January 1, 2022.  
The Statutory authority for Rule-making is G. S. 143-136; 143-138.

2018 NC Residential Code  
Chapter 44 Referenced Standards. (200901 Item B-6)

**REFERENCED STANDARDS**

ASTM

E283-04 Test Method for Determining the Rate of Air Leakage Through Exterior  
Windows, Curtain Walls and Doors Under Specified Pressure Differences Across the  
Specimen

.....N1102.4.6

The delayed effective date of this Rule is January 1, 2022.  
The Statutory authority for Rule-making is G. S. 143-136; 143-138.

## SECTION R4602 DEFINITIONS

**COASTAL HIGH HAZARD AREA.** ~~An area subject to coastal flooding and high velocity waters including storm wave wash, as shown by Federal Emergency Management Agency Maps and subject to the approval of the Building Code Council.~~ An area of special flood hazard extending from offshore to the inland limit of a primary frontal dune along an open coast and any other area subject to high velocity wave action from storms or seismic sources. The coastal high hazard area is identified as either V Zone or Coastal A Zone on Flood Insurance Rate Maps (FIRMs).

**CORROSION RESISTANCE AREA.** Areas within hurricane prone regions defined as that area east of the Intracoastal Waterway from the NC/SC state line north to Beaufort Inlet and from that point to include the barrier islands to the NC/VA state line.

**OCEAN HAZARD AREA.** ~~An area, as identified by the North Carolina Coastal Resources Commission, and subject to approval by the Building Code Council,~~ near the shoreline of the Atlantic Ocean that has been identified as subject to at least one of the following hazards: (A) Historical or predicted future trends of long-term erosion, (B) erosion expected to occur during a coastal storm reaching the base flood elevation, or (C) shoreline fluctuations due to tidal inlets.

The delayed effective date of this Rule is January 1, 2023.  
The Statutory authority for Rule-making is G. S. 143-136; 143-138.

2018 NC Residential Code  
R4603.6 Tying and bracing of wood piles (200714 Item B-21)

**R4603.6.1 Tying at corners.** At corners, girders shall be connected to the pile with a minimum 3/16 × 4 × 18-inch (5 × 102 × 467 mm) hot dip galvanized strap bolted with two 5/8 inch (15.9 mm) galvanized through bolts on the exterior and a minimum L4 x 4 x 3/16 x 1'-6" (102 × 5 × 467 mm) galvanized steel angle bolted with two 5/8 inch (15.9 mm) galvanized through bolts on the interior in accordance with Figure R4603.6(d), or with a minimum of (2) 3/16" x 4" x 18" (5x102x467 mm) hot dip galvanized straps installed on the outside of the girders with fasteners per Table R4603.6.1 and in accordance with Figure R4603.6 (e).

Table R4603.6.1  
Minimum Fastening of Corner Beams and Girder to Pilings

<u>Amount Piling is Notched</u>	<u>Associated Figure</u>	<u>Hardware</u>	<u>Fasteners</u>
<u>&gt; 50%<sup>1</sup></u>	<u>R4603.6(d)</u>	<u>one 3/16" x 4" x 18"</u>	<u>six 5/8" bolts<sup>2</sup></u>
		<u>one L4 x 4 x 3/16 x 18"</u>	
	<u>R4603.6 (e)</u>	<u>two 3/16" x 4" x 18"</u>	<u>eight 0.27"x4" each strap<sup>3</sup></u>

1. Where piling is notched over 50%, use strap as required in Section 4603.6. Install the specified number of bolts or screws in each end of the strap.
2. Bolts shall be 5/8" diameter hot dipped galvanized through bolts with nuts and washers.
3. Screws shall be 0.270" (6.9 mm) minimum in diameter, hot dipped galvanized to a minimum of A153, Class C, and have a minimum length of 4" or shall be long enough to penetrate through the girder and a minimum of one inch into the remaining pile, whichever is greater.

**R4603.6.2 Bracing of Pilings.** Bracing of pile foundations is required where the clear height from ground to sill, beam or girder exceeds 10 feet (3048 mm) or the dwelling is more than one story above piles. A line of X-bracing is defined as a row of piles with X-bracing provided in at least two bays. A line of X-bracing shall be provided at all exterior pile lines. Where the perimeter lines of X-bracing exceed 40 feet (12 192 mm), an additional line of X-bracing shall be provided near the center of the building. See Figure R4603.6(e)(f). X-bracing shall be with 2 × 10s through bolted with two 3/4-inch (19.1 mm) bolts at each end. The *code official* is permitted to accept alternate bracing designs if they bear the seal of a *registered design professional*.

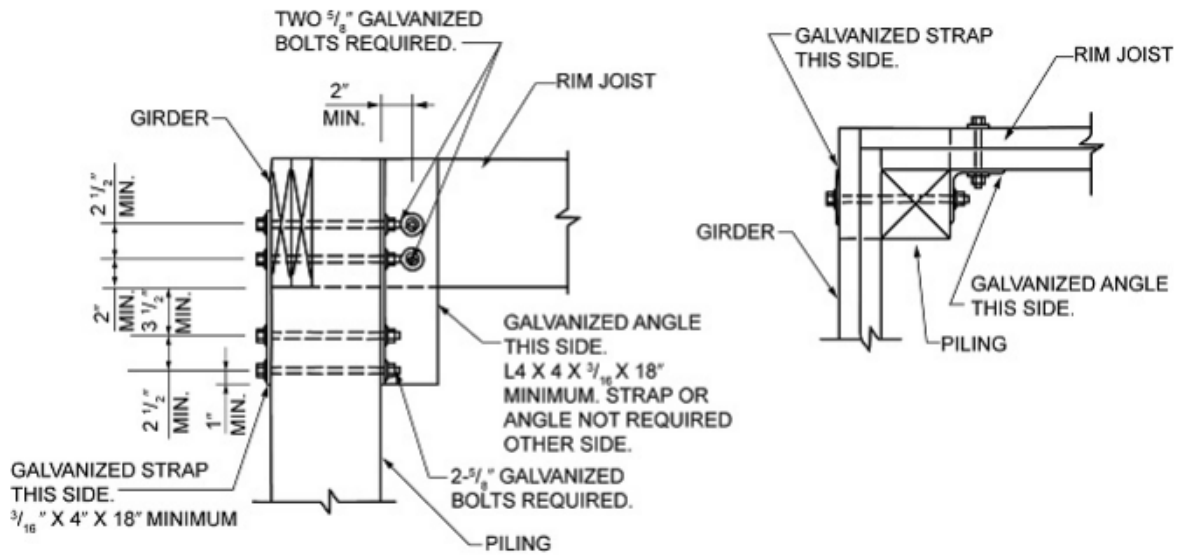

FIGURE R4603.6(d)  
CORNER PILE CONNECTION

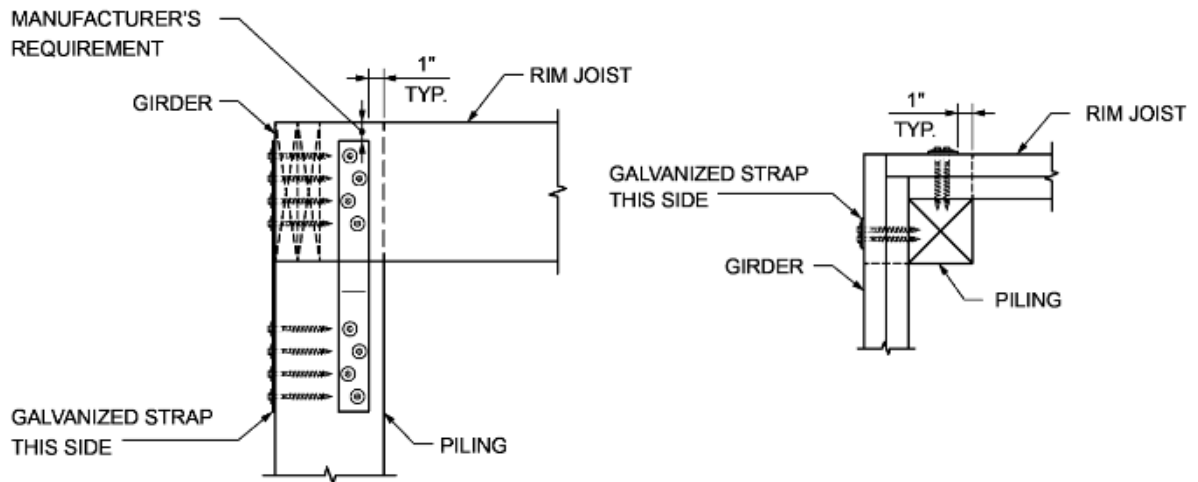

FIGURE R4603.6(e)  
CORNER PILE CONNECTION

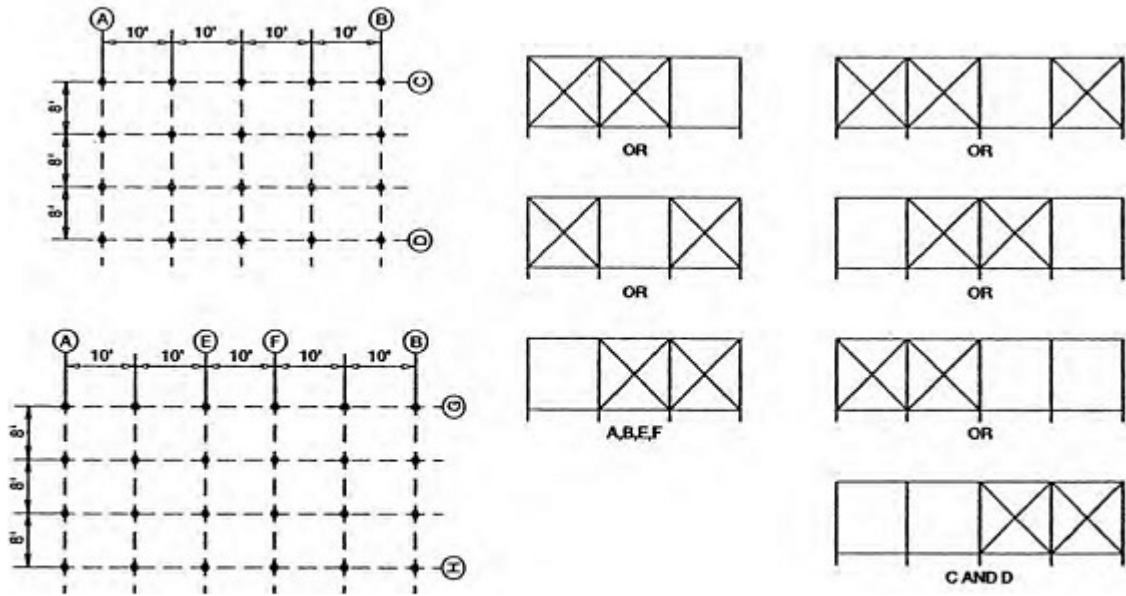

FIGURE R4603.6(e)(f)  
 ELEVATIONS  
 (SHOWING POSSIBLE ARRANGEMENT OF X-BRACING IN LINE) (G AND H SIMILAR)

The delayed effective date of this Rule is January 1, 2022.  
 The Statutory authority for Rule-making is G. S. 143-136; 143-138.

**R4603.6 Tying and bracing of wood piles.**

Beams and girders shall fully bear on pilings and butt joints shall occur over pilings. ~~If sills~~ Sills, beams or girders ~~are shall be~~ attached to the piling ~~a minimum of two 5/8 inch (16 mm) galvanized steel bolts per beam member shall be through bolted~~ using either bolts or screws at each piling connection in accordance with ~~Table R4603.6 and Figure R4503.6(a)~~ R4603.6(a). When ~~the~~ piling is notched so that the cross-section is reduced below 50 percent or ~~the girder is top bearing~~, sills, beams or girders shall be attached using 3/16 × 4 × 18-inch (5 × 102 × 467 mm) hot dip galvanized straps, one each side, ~~bolted with two 5/8 inch (15.9 mm) galvanized through bolts~~ fastened top and bottom with either bolts or screws in accordance with Table R4603.6 and Figure R4603.6(b) and Figure ~~R4503.6(e)~~ R4603.6(c). Where butt joints occur over the piling and screws are used, there shall be two straps on each side of the piling, having a minimum size of 3/16 × 2 × 18 inches (5 × 51 × 467 mm), with four self-drilling screws as described below in each end.

**Table R4603.6 Minimum Fastening of Beams and Girders to Pilings**

<u>Amount Piling is Notched</u>	<u>Beam/Girder Continuous</u>		<u>Beam/Girder Butt Joint</u>	
	<u>Bolts</u>	<u>Screws</u>	<u>Bolts</u>	<u>Screws</u>
<u>≤ 50%</u>	<u>two 5/8" bolts<sup>2</sup></u>	<u>four screws<sup>3</sup></u>	<u>four 5/8" bolts<sup>2</sup></u>	<u>eight screws<sup>3</sup></u>
<u>&gt; 50%<sup>1</sup></u>	<u>two 5/8" bolts<sup>2</sup></u>	<u>four screws<sup>3</sup></u>	<u>four 5/8" bolts<sup>3</sup></u>	<u>eight screws</u>

1. Where piling is notched over 50%, use strap as required in Section 4603.6. Install the specified number of bolts or screws in each end of the strap.
2. Bolts shall be 5/8" diameter hot dipped galvanized through bolts with nuts and washers.
3. Screws shall be 0.270" (6.9 mm) minimum in diameter, hot dipped galvanized to a minimum of A153, Class C, and having a minimum length of 4", and also shall be long enough to penetrate at least one inch through the remaining pile and into the girder.

**R4603.6.1 Tying at corners.** At corners, girders shall be connected to the pile with a minimum 3/16 × 4 × 18-inch (5 × 102 × 467 mm) hot dip galvanized strap bolted with two 5/8 inch (15.9 mm) galvanized through bolts on the exterior and a minimum L4 x 3/16 x 1'-6" (102 × 5 × 467 mm) galvanized steel angle bolted with two 5/8 inch (15.9 mm) galvanized through bolts on the interior in accordance with Figure R4603.6(d).

**R4603.6.2 Bracing of Pilings.** Bracing of pile foundations is required where the clear height from ground to sill, beam or girder exceeds 10 feet (3048 mm) or the dwelling is more than one story above piles. A line of X-bracing is defined as a row of piles with X-bracing provided in at least two bays. A line of X-bracing shall be provided at all exterior pile lines. Where the perimeter lines of X-bracing exceed 40 feet (12 192 mm), an additional line of X-bracing shall be provided near the center of the building. See Figure R4603.6(e). X-bracing shall be with 2 × 10s through bolted with two 3/4-inch (19.1 mm) bolts at each end. The code official is permitted to accept alternate bracing designs if they bear the seal of a registered design professional.



Revise Figures as follows:

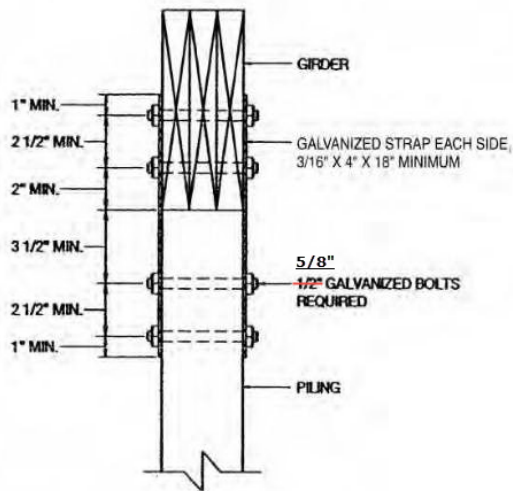

**FIGURE R4603.6(b)  
TOP MOUNTED GIRDER**

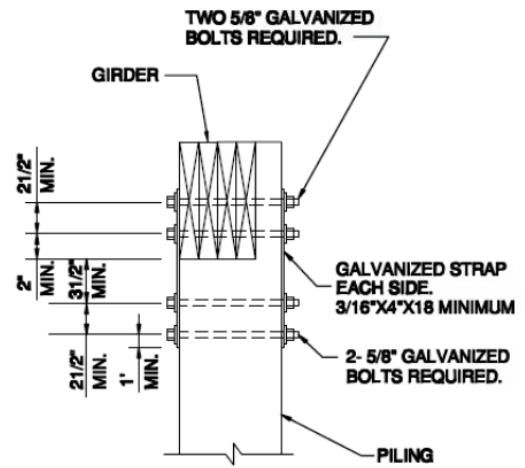

**FIGURE R4603.6(c)  
PILING NOTCHED MORE THAN 50%**

The delayed effective date of this Rule is January 1, 2020.  
The Statutory authority for Rule-making is G. S. 143-136; 143-138.

**SECTION R4606 FASTENER CORROSION RESISTANCE**

**R4605.5 R4606.1 Fastener corrosion resistance.**

In the *Coastal High Hazard Area*, the *Corrosion Resistance Area* and the *Ocean Hazard Area*, all metal connectors and fasteners outside of *conditioned spaces* shall be hot-dip galvanized steel after fabrication and meet ASTM A 153. Exposed metal connectors, such as tie-down straps on porches, decks, and areas under the structure, shall be a minimum 3/16-inch (5 mm) thick, and shall be hot-dip galvanized after fabrication and meet ASTM A 123 or ASTM A 153. Stainless steel light-gage metal connectors shall be permitted in exposed or partially exposed locations. Metal connectors of approved equivalent corrosion-resistant material are permitted to be accepted. See Table ~~R4605.5~~ R4606.1.

**TABLE ~~R4605.5~~\* R4606.1  
CORROSION RESISTANCE**

	<b>OPEN (exterior, porches, under house)</b>	<b>EXPOSURE LEVEL VENTED/ENCLOSED (attic, floor trusses, enclosed crawl spaces and stud cavity)</b>	<b>CONDITIONED (heated/cooled living areas)</b>
Nails, staples, screws	Hot-dip galvanized	Hot-dip galvanized	-
Nuts, bolts, washers, tie rods	Hot-dip galvanized	Hot-dip galvanized	-
Steel connection plates & straps (3/16" minimum thickness)	Hot-dip galvanized after fabrication	Hot-dip galvanized	-
Sheet metal connectors, wind anchors, joists hangers, steel joists and beams	Stainless steel or hot-dipped galvanized after fabrication	Hot-dip galvanized after plate fabrication or triple galvanized <sup>b</sup>	Hot-dip galvanized or triple galvanized <sup>b</sup>
Truss plates	Stainless steel or hot-dipped galvanized after fabrication	Hot-dip galvanized after fabrication, stainless steel, triple galvanized <sup>b</sup> or in accordance with TPI-1 of the Truss Plate Institute within 6'-0" of a gable louver, ridge or soffit vent. Otherwise, standard galvanized <sup>b</sup>	Standard galvanized

a. Applies only to structures located in *Coastal High Hazard Area*, *Corrosion Resistance Area* and *Ocean High Hazard Area*.

b. Triple galvanizing – G185, standard galvanizing – G60, both per ASTM A 653 / A 653M.

**R4605.6 R4605.5 Building anchorage.**

1. For masonry buildings, the roof structure, including rafters and joists, shall be anchored to the wall in accordance with Section R606.11. All mortar used for masonry walls shall be Type M or S.

2. For masonry or wood frame buildings, all sills, beams or girders which resist uplift (including interior sills, beams, girders, and joists where the perimeter is unenclosed) shall be anchored to the footing in accordance with Section R4504. Footing dowel bars shall have an 8-inch (203 mm) hook.

3. Where wood partitions and masonry walls join, the stud abutting the masonry shall be double and bolted to the masonry with three 1/2-inch (13 mm) galvanized bolts.

4. Steel and wooden columns and posts, including porch columns, shall be anchored with metal ties and bolts to their foundations and to the members that they support.

~~R4605.7~~ **R4605.6 Insulation.** Insulation installed in floors in exposed areas under buildings elevated on pilings shall be held in place with plywood with exterior glue or other material approved by the *code official*.

~~R4605.8~~ **R4605.7 Accessory structures.** Detached accessory structures and out buildings shall be bolted to their foundation or otherwise constructed so as to prevent overturning.

The delayed effective date of this Rule is January 1, 2023.  
The Statutory authority for Rule-making is G. S. 143-136; 143-138.

**AM105.1 General.**

Girders shall bear directly on the support post with the post attached at top to prevent lateral displacement or be connected to the side of the posts ~~with two 5/8 inch (16 mm) hot dip galvanized bolts with nut and washer~~ with one of the methods shown in Table AM105.1. Girder support is permitted to be installed in accordance with Figure AM105.1(1) for top mount; Figure AM105.1(2) for side mount and Figure AM105.1(3) for split girders. See Figure AM105.1(4) for cantilevered girders.

**Table AM105.1 Girder Connection to Side of Post**

<u>Maximum Girder Thickness</u>		
<u>Any</u>	<u>3" (Double 2X)</u>	<u>1-1/2" (Single 2X)</u>
<u>Two 5/8" diameter bolts<sup>1</sup></u>	<u>Four 6" long screws<sup>2</sup></u>	<u>Three 4" long screws<sup>2</sup></u>

1. Bolts shall be hot dip galvanized through bolts with nut and washer

2. Screws shall be hot dipped galvanized self-drilling screw fastener having a minimum diameter of 0.270", staggered so that the screws are not in a line, and having a minimum edge distance of 1-1/2 inches.

The delayed effective date of this Rule is January 1, 2020.  
The Statutory authority for Rule-making is G. S. 143-136; 143-138.

**AM109.1 Deck bracing.**

Decks shall be braced to provide lateral stability. Lateral stability shall be provided in accordance with one of the methods in Sections AM109.1.1 through AM109.1.5.

**AM109.1.1. Lateral bracing not required.**

When the deck floor height is less than 4 feet (1219 mm) above finished grade as shown in Figure AM109.1(1) and the deck is attached to the structure in accordance with Section AM104, lateral bracing is not required. Lateral bracing is not required for freestanding decks with a deck floor height 30 inches (762 mm) or less above finished grade.

**AM109.1.2. Knee bracing.**

4x4 wood knee braces are permitted to be provided on each column in both directions for freestanding decks or parallel to the structure at the exterior column line for attached decks per Figure AM109.1(2). The knee braces shall attach to each post at a point not less than 1/3 of the post length from the top of the post, and the braces shall be angled between 45 degrees (0.79 rad) and 60 degrees (1.05 rad) from the horizontal. Knee braces shall be ~~bolted~~ fastened to the post and the girder/double band in accordance with one 5/8 inch (16 mm) hot dip galvanized bolt with nut and washer at both ends of the brace of the methods shown in Table AM109.1. as shown in Figure AM109.1(2).

**TABLE AM109.1**  
**FASTENING OF BRACE TO POST AND GIRDER/BAND (CHOOSE ONE)**

<u>Fastener</u>	<u>Installation</u>	<u>Minimum Distances</u>
<u>One 5/8" diameter hot dipped galvanized through bolt with nut and washer</u>	<u>Perpendicular to post or girder/band</u>	<u>2-3/16" end distance</u>
<u>Two hot dipped galvanized (ASTM A153, Class C, minimum) screws having minimum diameter of 0.270" and long enough to achieve 3" penetration into the post or girder/band.</u>	<u>Perpendicular to post or girder/band</u>	<u>1" edge distance, 1-1/2" horizontal spacing, minimum 3" end distance</u>

**AM109.1.3. Post embedment.**

For free standing decks without knee braces or diagonal bracing, lateral stability is permitted to be provided by embedding the post in accordance with Figure AM109.1(3) and ~~Table AM109.1~~ Table AM109.2.

**TABLE AM109.1 AM109.2**  
**POST EMBEDMENT FOR FREE STANDING DECKS**

<b>POST SIZE</b>	<b>MAXIMUM TRIBUTARY AREA</b>	<b>MAXIMUM POST HEIGHT</b>	<b>EMBEDMENT DEPTH</b>	<b>CONCRETE DIAMETER</b>
4" x 4"	48 SF	4'-0"	2'-6"	1'-0"
6" x 6"	120 SF	6'-0"	3'-6"	1'-8"

**AM109.1.4. Cross bracing.**

2x6 diagonal vertical cross bracing is permitted to be provided in two perpendicular directions for free standing decks or parallel to the structure at the exterior column line for attached decks. The 2x6 bracing shall be attached to the posts with one 5/8 inch (16 mm) hot dip galvanized bolt with nut and washer at each end of each bracing member per Figure AM109.1(4).

**AM109.1.5. Piles in coastal regions.**

For embedment of piles in coastal regions, see Chapter 46.

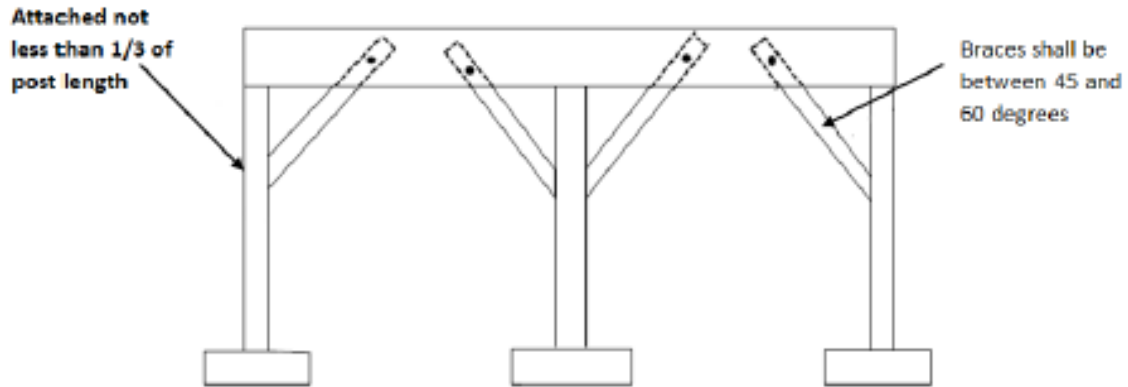

**FIGURE AM109.1(2)  
KNEE BRACING**

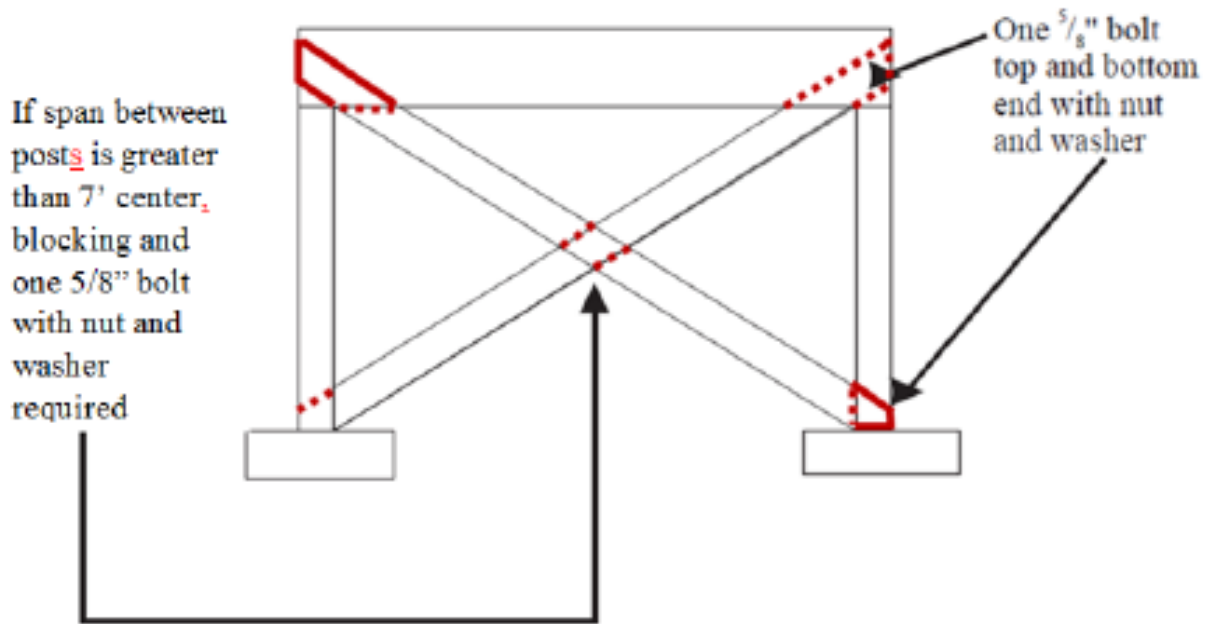

**FIGURE AM109.1(4)  
CROSS BRACING**

The delayed effective date of this Rule is January 1, 2020.  
The Statutory authority for Rule-making is G. S. 143-136; 143-138.

**AM109.1.4 Cross bracing.**

2x6 diagonal vertical cross bracing is permitted to be provided in two perpendicular directions for free standing decks or parallel to the structure at the exterior column line for attached decks. The 2x6 bracing shall be attached to the posts with one ~~of the methods in Table AM109.1.4~~ ~~5/8-inch (16 mm) hot dip galvanized bolt with nut and washer~~ at each end of each bracing member in accordance with Figure AM109.1(4).

**Table AM109.1.4  
 FASTENING OF BRACE (CHOOSE ONE)**

<u>Fastener Type</u>	<u>Diameter (inches)</u>	<u>QTY</u>	<u>Length</u>
<u>Bolt</u>	<u>5/8<sup>a</sup></u>	<u>1</u>	<u>As required</u>
<u>Screws</u>	<u>0.27<sup>b</sup></u>	<u>2</u>	<u>Long enough to achieve a 1 1/2" thread penetration of structural member opposite head of screw</u>

a. Bolts shall be hot dip galvanized through bolts with nut and washer

b. Screws shall be hot dip galvanized (ASTM A153, Class C, minimum) self drilling screw fastener having a minimum diameter of 0.27", and installed in the center of the post with a minimum of 1" space between screws.

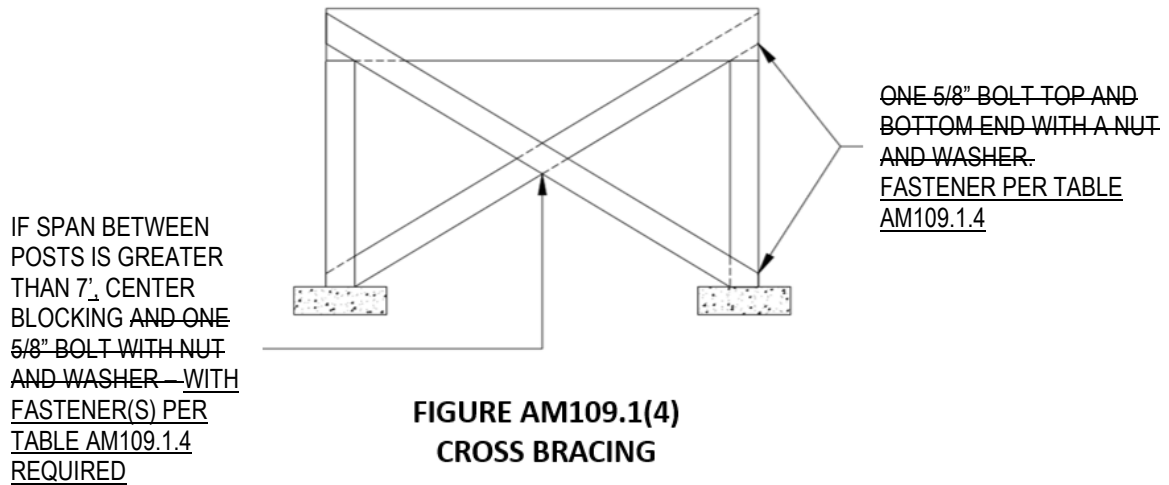

The delayed effective date of this Rule is January 1, 2021.  
 The Statutory authority for Rule-making is G. S. 143-136; 143-138.

2018 NC Residential Code

**ERRATA** – Figure AM109.1(4) corrected bracing location and lapping (200708).

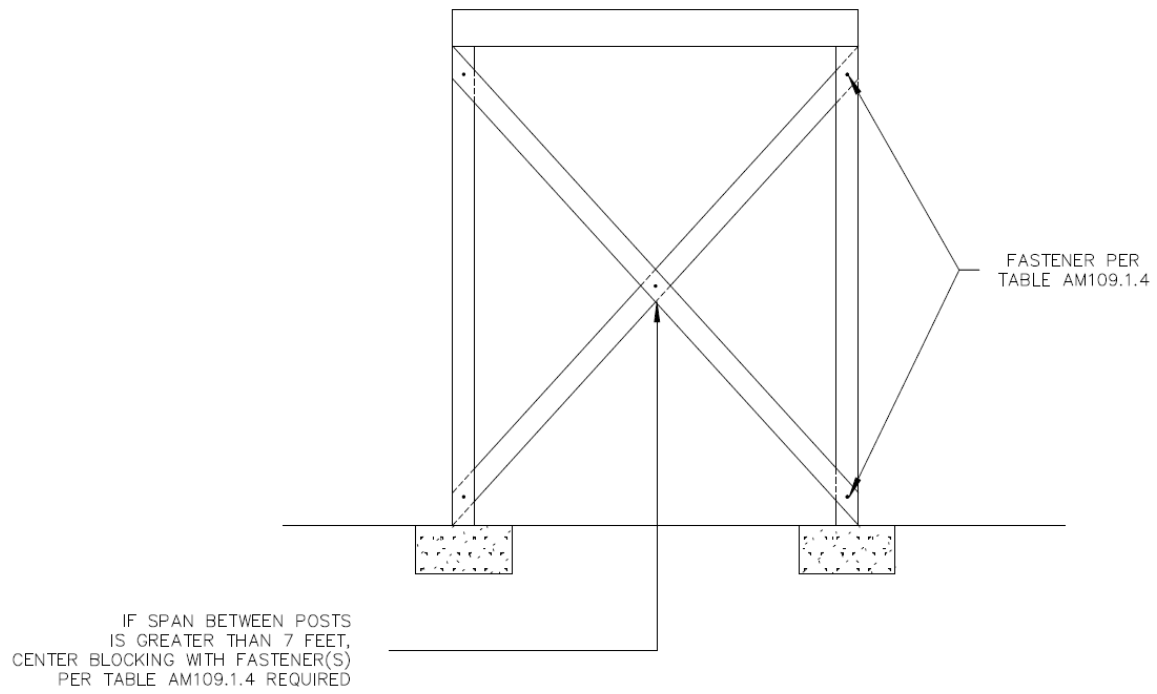



## **APPENDIX Q TINY HOUSES**

The provisions contained in this appendix are adopted as part of this code.

### **SECTION AQ101 GENERAL**

**AQ101.1 Scope.** This appendix shall be applicable to *tiny houses* used as single *dwelling unit*. *Tiny houses* shall comply with this code except as otherwise stated in this appendix.

### **SECTION AQ102 DEFINITIONS**

**AQ102.1 General.** The following words and terms shall, for the purposes of this appendix, have the meanings shown herein. Refer to Chapter 2 of this code for general definitions.

**LANDING PLATFORM.** A landing provided as the top step of a *stairway* accessing a *loft*.

**HABITABLE LOFT.** A floor level located more than 30 inches above the main floor and open to the main floor on one or more sides with a ceiling height of less than 6 feet 8 inches and used as a living or sleeping space.

**TINY HOUSE.** A *dwelling* that is 400 square feet or less in floor area excluding *lofts*.

### **SECTION AQ103 LOFTS**

**AQ103.1 General.** *Lofts* used as a sleeping or living space shall meet the minimum area and dimension requirements of Sections AQ103.1.1 through AQ103.1.4.

**AQ103.1.1 Minimum area.** *Lofts* shall have a floor area of not less than 35 square feet.

**AQ103.1.2 Minimum dimensions.** *Lofts* shall be not less than 5 feet in any horizontal dimension.

**AQ103.1.3 Minimum ceiling height.** *Habitable space* and hallways in *tiny houses* shall have a *ceiling height* of not less than 6 feet 8 inches. *Bathrooms, toilet rooms* and *kitchens* shall have a *ceiling height* of not less than 6 feet 4 inches. Obstructions including, but not limited to, beams, girders, *ducts* and lighting, shall not extend below these minimum *ceiling heights*.

**Exception:** *Ceiling heights* in *lofts* are permitted to be less than 6 feet 8 inches.

**AQ104.1.4 Height effect on loft area.** Portions of a *loft* with a sloped ceiling measuring less than 3 feet from the finished floor to the finished ceiling shall not be considered as contributing to the minimum required area for the *loft*.

**Exception:** Under gable roofs with a minimum slope of 6 units vertical in 12 units horizontal (50-percent slope), portions of a *loft* with a sloped ceiling measuring less than 16 inches from the finished floor to the finished ceiling shall not be considered as contributing to the minimum required area for the *loft*.

### **SECTION AQ104 MEANS OF EGRESS**

**AQ104.1 Loft access.** The access to and primary egress from *lofts* shall be of any type described in Sections AQ104.2.1 through AQ104.2.4.

**AQ104.2.1 Stairways.** *Stairways* accessing *lofts* shall comply with this code or with Sections AQ104.2.1.1 through AQ104.2.1.5.

**AQ104.2.1.1 Width.** *Stairways* accessing a *loft* shall not be less than 20 inches in clear width including *handrail*.

**AQ104.2.1.2 Headroom.** The headroom in *stairways* accessing a *loft* shall be not less than 6 feet 2 inches, as measured vertically, from a sloped line connecting the tread or *landing platform nosing* in the middle of their width.

**AQ104.2.1.3 Treads and risers.** *Risers* for *stairs* accessing a *loft* shall be a maximum of 12 inches in height and every *riser* shall be uniform within a tolerance of  $\frac{3}{4}$ ". Tread depth shall be a minimum 12" with all treads uniform within a tolerance  $\frac{3}{4}$ ".

**AQ104.2.1.4 Landing platforms.** The top tread and *riser* of *stairways* accessing *lofts* shall be constructed as a *landing platform* where the *loft ceiling height* is less than 6 feet 2 inches where the *stairway* meets the *loft*. The *landing platform* shall be the width of the *stairs* with a minimum depth of 18" inches measured from the *nosing* of the *landing platform* to the edge of the *loft*, and 16 to 18 inches in height measured from the *landing platform* to the *loft* floor.

**AQ104.2.1.5 Handrails.** *Handrails* shall comply with Section R311.7.8.

**AQ104.2.1.6 Stairway guards.** *Guards* at open sides of *stairways* shall comply with Section R312.1.

**AQ104.2.2 Ladders.** Non-removable ladders accessing *lofts* shall comply with Sections AQ104.2.2.1.

**Exception:** Ladders that slide out away from the *loft* opening that are within reach of the *loft* occupant.

**AQ104.2.2.1 Size and capacity.** Ladders accessing *lofts* shall have a rung width of not less than 12 inches, and no more than 18-inches spacing between rungs. Ladders shall be capable of supporting a 200-pound load on any rung. Rung spacing shall be uniform within  $\frac{3}{8}$  inch.

**AQ104.2.3 Ship's ladders.** Ship's ladders accessing *lofts* shall be installed at 70 to 80 degrees from horizontal and are permitted to be used as an element of a means of egress from *lofts*. *Ship ladders* shall comply with Sections R311.7.12.

**AQ104.2.4 Loft Guards.** *Loft guards* complying with R312.1 shall be located along the open side of *lofts*. *Loft guards* shall be not less than 36 inches in height or one-half of the clear height to the ceiling, whichever is less.

## **SECTION AQ105 EMERGENCY ESCAPE AND RESCUE**

**AS105.1 Emergency Escape and Rescue.** *Tiny houses* and their *lofts* shall meet the requirements of Section R310 for emergency escape and rescue openings.

## **SECTION AQ106 SMOKE AND CARBON MONOXIDE DETECTORS**

**AQ106.1 Smoke and Carbon monoxide detectors.** Smoke and carbon monoxide detectors shall be installed as required in Sections R314 and R315 and just below the highest point of any *loft*.

## **SECTION AQ107 FOUNDATION**

**AQ107.1 Foundation options.** *Tiny Houses* are permitted to be constructed without a masonry or concrete foundation per Section AQ107.1.1 and AQ107.1.2, except in *coastal high hazard, ocean hazard* and *flood hazard areas*.

**AQ107.1.1 Wood Foundation.** The building shall be supported on a wood foundation of minimum 4-inch by 4-inch or 6-inch by 6-inch mudsill or runner of approved wood in accordance with Section R317. Structural floor systems that include joists and subfloor material shall also comply with Section R317.1, item #1.

**AQ107.1.2. Anchorage.** *Tiny houses* with wood foundations per AQ107.1.1 shall be designed and anchored to resist overturning and sliding.

**Exception:** *Tiny houses* with no more than 12' vertical mean roof height shall be anchored to resist overturning and sliding by installing a minimum of one ground anchor at each corner of the building. The total resisting force of the anchors shall be equal to 20psf (958 Pa) times the plan area of the building.

The delayed effective date of this Rule is January 1, 2023.  
The Statutory authority for Rule-making is G. S. 143-136; 143-138.