

APPENDIX C
CODE CHANGE PROPOSAL
NORTH CAROLINA
BUILDING CODE COUNCIL

B-6

325 North Salisbury Street, Room 5_44
Raleigh, North Carolina 27603
(919) 647-0009
carl.martin@ncdoi.gov

Granted by BCC _____ Petition for Rule Making Item Number _____
Denied by BCC _____ Adopted by BCC _____ Approved by RRC _____
Disapproved by BCC _____ Objection by RRC _____

PROPONENT: Gloria Shealey, Chair of the BCC Energy Code Standing Committee PHONE: (919) 888-0284

REPRESENTING: BCC Energy Code Standing Committee

ADDRESS: Mail Service Center 1202

CITY: Raleigh STATE: NC ZIP: 27699-1202

E-MAIL: carl.martin@ncdoi.gov FAX: () -

North Carolina State Building Code, Volume 2024 NC Residential Code-Chapter 11 Section _____

CHECK ONE: [] Revise section to read as follows: [] Delete section and substitute the following:
[X] Add new section to read as follows: [] Delete section without substitution:

~~LINE THROUGH MATERIAL TO BE DELETED~~

UNDERLINE MATERIAL TO BE ADDED

Please type. Continue proposal or reason on plain paper attached to this form. See reverse side for instructions.

The 2024 NCRC-Chapter 11 is based on Chapter 11 of the 2021 IRC which can be viewed at: [Digital Codes \(iccsafe.org\)](https://www.iccsafe.org)
The NC amendments to Chapter 11 of the 2021 IRC that make up 2024 NCRC-Chapter 11 are shown in ATTACHMENT A below

Will this proposal change the cost of construction? Decrease [] Increase [] No [X]
Will this proposal increase to the cost of a dwelling by \$80 or more? Yes [] No [X]
Will this proposal affect the Local or State funds? Local [] State [] No [X]
Will this proposal cause a substantial economic impact (≥\$1,000,000)? Yes [] No [X]

- Non-Substantial – Provide an economic analysis including benefit/cost estimates.
- Substantial – The economic analysis must also include 2-alternatives, time value of money and risk analysis.
- Pursuant to §143-138(a1)(2) a cost-benefit analysis is required for all proposed amendments to the NC Energy Conservation Code. The Building Code Council shall also require same for the NC Residential Code, Chapter 11.

REASON: This amendment is proposed to protect the public by updating the code to current standards of practice.

BCC CODE CHANGES

Signature: CARL MARTIN Date: Febraury 1, 2023

FORM 11/26/19

ATTACHMENT A

THIS DOCUMENT CONTAINS PROPOSED NORTH CAROLINA AMENDMENTS TO THE 2021 EDITION OF THE INTERNATIONAL RESIDENTIAL CODE (IRC) FOR THE PURPOSE OF ESTABLISHING THE 2024 EDITION OF THE NORTH CAROLINA RESIDENTIAL CODE.

UNDERLINED TEXT INDICATE NORTH CAROLINA PROPOSED AMENDMENTS TO THE 2021 INTERNATIONAL RESIDENTIAL CODE FOR THE 2024 NORTH CAROLINA RESIDENTIAL CODE.

~~STRUCKTHROUGH~~ TEXT INDICATES IRC TEXT THAT IS PROPOSED TO BE REMOVED FROM THE 2024 NORTH CAROLINA RESIDENTIAL CODE.

TEXT THAT IS HIGHLIGHTED IN **YELLOW** INDICATES PROPOSED NORTH CAROLINA AMENDMENTS THAT ARE NEW OR DIFFERENT THAN THE 2018 NORTH CAROLINA RESIDENTIAL CODE.

Part IV—Energy Conservation

CHAPTER 11 [RE] ENERGY EFFICIENCY

User note:

~~— **About this chapter:** The purpose of Chapter 11 [RE] is to provide minimum design requirements that will promote efficient utilization of energy in buildings. The requirements are directed toward the design of building envelopes with adequate thermal resistance and low air leakage, and toward the design and selection of mechanical, water heating, electrical and illumination systems that promote effective use of depletable energy resources.~~

SECTION N1101 GENERAL

N1101.1 Scope. This chapter regulates the energy efficiency for the design and construction of buildings regulated by this code.

*Note: The text of Sections N1101.2 through N1113 parallels the text of the 2021/2024 edition of the **International North Carolina Energy Conservation Code—Residential Provisions (IECC-R)** and has been editorially revised to conform to the scope and application of this code. The section numbers appearing in parenthesis after each section number are the section numbers of the corresponding text in the **IECC-R, North Carolina Energy Conservation Code—Residential Provisions**. If a section does not have a section number in parenthesis after it, then there is no corresponding text in the IECC-R.*

N1101.2 (R101.3) Intent. This chapter shall regulate the design and construction of *buildings* for the effective use and conservation of energy over the useful life of each *building*. This chapter is intended to provide flexibility to permit the use of innovative approaches and techniques to achieve this objective. This chapter is not intended to abridge safety, health or environmental requirements contained in other applicable codes or ordinances.

N1101.3 (R101.5.1) Compliance materials. The *code official* shall be permitted to approve specific computer software, worksheets, compliance manuals and other similar materials that meet the intent of this chapter.

N1101.4 (R102.1.1) Above code programs. The *code official* or other authority having *jurisdiction* shall be permitted to deem a national, state or local energy-efficiency program to exceed the energy efficiency required by this code. *Buildings approved* in writing by such an energy-efficiency program shall be considered to be in compliance with this code. The requirements identified in Table N1105.2, as applicable, shall be met, where such buildings also meet the requirements identified in Table R405.2 and the *building thermal envelope* is greater than or equal to levels of efficiency and solar heat gain coefficients (SHGC) in Tables 402.1.1 and 402.1.3 of the 2009 *International Energy Conservation Code*.

N1101.5 (R103.1) General. Construction documents, technical reports and other supporting data shall be submitted in one or more sets, or in a digital format where allowed by the *code official*, with each application for a permit. The construction documents and technical reports shall be prepared by a registered design professional where required by the statutes of the jurisdiction in which the project is to be constructed. Where special conditions exist, the *code official* is authorized to require necessary construction documents to be prepared by a registered design professional.

Exceptions:

1. The *code official* is authorized to waive the requirements for construction documents or other supporting data if the *code official* determines they are not necessary to confirm compliance with this code.
2. Refer to (NCGS 160D-1110 (b) for statutory limitations on requirements for one-and-two family dwellings and townhouses plans.

N1101.5.1 (R103.2) Information on construction documents. Construction documents shall be drawn to scale on suitable material. Electronic media documents are permitted to be submitted when *approved* by the *code official*. Construction documents shall be of sufficient clarity to indicate the location, nature and extent of the work proposed, and show in sufficient detail pertinent data and features of the building, systems and equipment as herein governed. Details shall include the following as applicable:

1. Energy compliance path.
2. Insulation materials and their *R*-values.
3. Fenestration *U*-factors and solar heat gain coefficients (SHGC).
4. Area-weighted *U*-factor and solar heat gain coefficient (SHGC) calculations.
5. Mechanical system design criteria.
6. Mechanical and service water heating systems and equipment types, sizes and efficiencies.
7. Equipment and system controls.
8. Duct sealing, duct and pipe insulation and location.
9. Air sealing details.

N1101.5.1 (R103.2.1) Building thermal envelope depiction. The *building thermal envelope* shall be represented on the *construction documents*.

N1101.6 (R202) Defined terms. The following words and terms shall, for the purposes of this chapter, have the meanings shown herein.

ABOVE-GRADE WALL. A wall more than 50 percent above grade and enclosing *conditioned space*. This includes between-floor spandrels, peripheral edges of floors, roof and *basement* knee walls, dormer walls, gable end walls, walls enclosing a mansard roof and *skylight* shafts.

ACCESS (TO). That which enables a device, appliance or equipment to be reached by *ready access* or by a means that first requires the removal or movement of a panel or similar obstruction. □

ADDITION. An extension or increase in the *conditioned space* floor area, number of stories or height of a building or structure.

AIR BARRIER. One or more materials joined together in a continuous manner to restrict or prevent the passage of air through the *building thermal envelope* and its assemblies. □

AIR BARRIER MATERIAL. Material(s) that have an air permeability not to exceed 0.004 cfm/ft² under a pressure differential of 0.3 in. water (1.57psf) (0.02 L/s.m² @ 75 Pa) when tested in accordance with ASTM E2178.

AIR BARRIER SYSTEM. Material(s) assembled and joined together to provide a barrier to air leakage through the building envelope. An air barrier system is a combination of air barrier materials and sealants.

ALTERATION. Any construction, retrofit or renovation to an existing structure other than *repair* or *addition*. Also, a change in a building, electrical, gas, mechanical or plumbing system that involves an extension, *addition* or change to the arrangement, type or purpose of the original installation.

APPROVED. Acceptable to the *code official*.

APPROVED AGENCY. An established and recognized agency that is regularly engaged in conducting tests furnishing inspection services, or furnishing product certification, where such agency has been *approved* by the *code official*.

AUTOMATIC. Self-acting, operating by its own mechanism when actuated by some impersonal influence, as, for example, a change in current strength, pressure, temperature or mechanical configuration (see “*Manual*”).

BASEMENT WALL. A wall 50 percent or more below grade and enclosing *conditioned space*.

BUILDING. Any structure used or intended for supporting or sheltering any use or occupancy, including any mechanical systems, service water-heating systems and electric power and lighting systems located on the *building site* and supporting the building.

BUILDING SITE. A contiguous area of land that is under the ownership or control of one entity.

BUILDING THERMAL ENVELOPE. The *basement walls, exterior walls, floors, ceilings, roofs and any other building element assemblies that enclose conditioned space* or provide a boundary between *conditioned space* and exempt or *unconditioned space*.

CAVITY INSULATION. Insulating material located between framing members.

CIRCULATING HOT WATER SYSTEM. A specifically designed water distribution system where one or more pumps are operated in the service hot water piping to circulate heated water from the water-heating equipment to fixtures and back to the water-heating equipment.

CLIMATE ZONE. A geographical region based on climatic criteria as specified in this code.

CLOSED CRAWL SPACE. A foundation without wall vents that uses air sealed walls, ground and foundation moisture control, and mechanical drying potential to control crawl space moisture. Insulation may be located at the floor level or at the exterior walls

CONDITIONED FLOOR AREA. The horizontal projection of the floors associated with the *conditioned space*.

CONDITIONED SPACE. An area, room or space that is enclosed within the *building thermal envelope* and that is directly heated or cooled or indirectly heated or cooled. Spaces are indirectly heated or cooled where they communicate through openings with *conditioned spaces*, where they are separated from *conditioned spaces* by uninsulated walls, floors or ceilings, or where they contain uninsulated ducts, piping or other sources of heating or cooling.

CONTINUOUS AIR BARRIER. A combination of materials and assemblies that restrict or prevent the passage of air through the *building thermal envelope*.

CONTINUOUS INSULATION (ci). Insulating material that is continuous across all structural members without thermal bridges other than fasteners and service openings. It is installed on the interior or exterior, or is integral to any opaque surface, of the *building envelope*.

CRAWL SPACE WALL. The opaque portion of a wall that encloses a *crawl space* and is partially or totally below grade.

CURTAIN WALL. Fenestration products used to create an external nonload-bearing wall that is designed to separate the exterior and interior environments.

DEMAND RECIRCULATION WATER SYSTEM. A water distribution system where one or more pumps prime the service hot water piping with heated water on demand for hot water.

DIMMER. A control device that is capable of continuously varying the light output and energy use of light sources.

DUCT. A tube or conduit utilized for conveying air. The air passages of self-contained systems are not to be construed as air ducts.

DUCT SYSTEM. A continuous passageway for the transmission of air that, in addition to ducts, includes duct fittings, dampers, plenums, fans and accessory air-handling equipment and appliances.

DWELLING UNIT. A single unit providing complete independent living facilities for one or more persons, including permanent provisions for living, sleeping, eating, cooking and sanitation.

DWELLING UNIT ENCLOSURE AREA. The sum of the area of ceiling, floors and walls separating a dwelling unit's conditioned space from the exterior or from adjacent conditioned or unconditioned spaces. Wall height shall be measured from the finished floor of the dwelling unit to the underside of the floor above.

ENERGY ANALYSIS. A method for estimating the annual energy use of the proposed design and standard reference design based on estimates of energy use.

ENERGY COST. The total estimated annual cost for purchased energy for the building functions regulated by this code, including applicable demand charges.

ENERGY SIMULATION TOOL. An *approved* software program or calculation-based methodology that projects the annual energy use of a *building*.

ERI REFERENCE DESIGN. A version of the *rated design* that meets the minimum requirements of the 2006 *International Energy Conservation Code*.

EXTERIOR WALL. Walls including both above-grade walls and *basement walls*.

FENESTRATION. Products classified as either *vertical fenestration* or *skylights*.

Skylights. Glass or other transparent or translucent glazing material installed at a slope of less than 60 degrees (1.05 rad) from horizontal, including *unit skylights*, *tubular daylighting devices*, and glazing materials in solariums, *sunrooms*, roofs and sloped walls.

Vertical fenestration. Windows that are fixed or operable, opaque doors, glazed doors, glazed block and combination opaque/glazed doors composed of glass or other transparent or translucent glazing materials and installed at a slope of not less than 60 degrees (1.05 rad) from horizontal.

FENESTRATION PRODUCT, FIELD-FABRICATED. A fenestration product whose frame is made at the construction site of standard dimensional lumber or other materials that were not previously cut, or otherwise formed with the specific intention of being used to fabricate a fenestration product or exterior door. Field fabricated does not include site-built fenestration.

FENESTRATION PRODUCT, SITE-BUILT. A fenestration designed to be made up of field-glazed or field-assembled units using specific factory cut or otherwise factory-formed framing and glazing units. Examples of site-built fenestration include storefront systems, curtain walls, and atrium roof systems.

HEATED SLAB. Slab-on-grade construction in which the heating elements, hydronic tubing, or hot air distribution system is in contact with, or placed within or under, the slab.

HIGH-EFFICACY LIGHT SOURCES. Compact fluorescent lamps, light-emitting diode (LED) lamps, T-8 or smaller diameter linear fluorescent lamps, other lamps with an efficacy of not less than 65 lumens per watt, or luminaires with an efficacy of not less than 45 lumens per watt.

HISTORIC BUILDING. Any building or structure that is one or more of the following:

1. Listed, or certified as eligible for listing by the State Historic Preservation Officer or the Keeper of the National Register of Historic Places, in the National Register of Historic Places.
2. Designated as historic under an applicable state or local law.
3. Certified as a contributing resource within a National Register-listed, state-designated or locally designated historic district.

HERS RATER. An individual that has completed training and been certified by RESNET (Residential Energy Services Network) Accredited Rating Provider and has a current certification.

INFILTRATION. The uncontrolled inward air leakage into a building caused by the pressure effects of wind or the effect of differences in the indoor and outdoor air density or both.

INSULATED SIDING. A type of continuous insulation with manufacturer-installed insulating material as an integral part of the cladding product having an *R*-value of not less than R-2.

INSULATING SHEATHING. An insulating board with a core material having an *R*-value of not less than R-2.

LABELED. Appliances, equipment, ~~Equipment~~, materials or products to which have been affixed a label, seal, symbol or other identifying mark of a nationally recognized testing laboratory, approved agency or other organization concerned with product evaluation that maintains periodic inspection of the production of such labeled items and whose labeling indicates either that the appliances, equipment, material or product meets identified standards or has been tested and found suitable for a specified purpose.

LISTED. Appliances. Equipment, materials, products or services included in a list published by an organization acceptable to the *code official* and concerned with evaluation of products or services that maintains periodic inspection of production of *listed appliances*, equipment or materials or periodic evaluation of services and whose listing states either that the equipment, material, product or service meets identified standards or has been tested and found suitable for a specified purpose.

MANUAL. Capable of being operated by personal intervention (see “*Automatic*”).

OCCUPANT SENSOR CONTROL. An automatic control device that detects the presence or absence of people within an area and causes lighting, equipment or appliances to be regulated accordingly.

ON-SITE RENEWABLE ENERGY. Energy from renewable energy resources harvested at the building site.

OPAQUE DOOR. A door that is not less than 50-percent opaque in surface area.

PROPOSED DESIGN. A description of the proposed building used to estimate annual energy use for determining compliance based on total building performance.

RATED DESIGN. A description of the proposed *building* used to determine the energy rating index. □

REGISTERED DESIGN PROFESSIONAL. An individual who is registered or licensed to practice their respective design profession as defined by the statutory requirements of the professional registration laws of the state or jurisdiction in which the project is to be constructed. Design by a registered design professional is not required where exempt under the registration or licensure laws.

READY ACCESS (TO). That which enables a device, appliance or equipment to be directly reached without requiring the removal or movement of any panel or similar obstruction.

RENEWABLE ENERGY CERTIFICATE (REC). An instrument that represents the environmental attributes of one megawatt hour of renewable energy; also known as an energy attribute certificate (EAC).

RENEWABLE ENERGY RESOURCES. Energy derived from solar radiation, wind, waves, tides, landfill gas, biogas, biomass or extracted from hot fluid or steam heated within the earth.

REPAIR. The reconstruction or renewal of any part of an existing *building* for the purpose of its maintenance or to correct damage.

REROOFING. The process of recovering or replacing an existing roof covering. See “*Roof recover*” and “*Roof replacement*.”

RESIDENTIAL BUILDING. For this chapter, includes detached one- and two-family dwellings and townhouses as well as Group R-2, R-3 and R-4 buildings three stories or less in height above *grade plane*.

ROOF ASSEMBLY. A system designed to provide weather protection and resistance to design loads. The system consists of a roof covering and *roof deck* or a single component serving as both the roof covering and the *roof deck*. A *roof assembly* includes the roof covering, underlayment, and *roof deck*, and can also include a thermal barrier, ignition barrier, insulation or a vapor retarder.

ROOF RECOVER. The process of installing an additional roof covering over an existing roof covering without removing the existing roof covering.

ROOF REPAIR. Reconstruction or renewal of any part of an existing roof for the purposes of its maintenance.

ROOF REPLACEMENT. The process of removing the existing roof covering, repairing any damaged substrate and installing a new roof covering.

R-VALUE (THERMAL RESISTANCE). The inverse of the time rate of heat flow through a body from one of its bounding surfaces to the other surface for a unit temperature difference between the two surfaces, under steady state conditions, per unit area ($h \times \text{ft}^2 \times \text{°F/Btu}$) [$\text{m}^2 \times \text{K/W}$].

SITE-RECOVERED ENERGY. Waste energy recovered at the building site that is used to off-set consumption of purchased fuel or electrical energy supplies.

SERVICE WATER HEATING. Supply of hot water for purposes other than comfort heating.

SOLAR HEAT GAIN COEFFICIENT (SHGC). The ratio of the solar heat gain entering the space through the fenestration assembly to the incident solar radiation. Solar heat gain includes directly transmitted solar heat and absorbed solar radiation that is then reradiated, conducted or convected into the space.

STANDARD REFERENCE DESIGN. A version of the *proposed design* that meets the minimum requirements of this code and is used to determine the maximum annual energy use requirement for compliance based on total building performance.

SUNROOM. A one-story structure attached to a dwelling with a glazing area in excess of 40 percent of the gross area of the structure's *exterior walls* and roof.

THERMAL DISTRIBUTION EFFICIENCY (TDE). The resistance to changes in air heat as air is conveyed through a distance of air duct. TDE is a heat-loss calculation evaluating the difference in the heat of the air between the air duct inlet and outlet caused by differences in temperatures between the air in the duct and the duct material. TDE is expressed as a percent difference between the inlet and outlet heat in the duct.

THERMAL ISOLATION. Physical and space conditioning separation from *conditioned spaces*. The *conditioned spaces* shall be controlled as separate *zones* for heating and cooling or conditioned by separate equipment.

THERMOSTAT. An automatic control device used to maintain temperature at a fixed or adjustable set point.

U-FACTOR (THERMAL TRANSMITTANCE). The coefficient of heat transmission (air to air) through a building component or assembly, equal to the time rate of heat flow per unit area and unit temperature difference between the warm side and cold side air films (Btu/h × ft² × °F) [W/(m² × K)].

VENTILATION. The natural or mechanical process of supplying conditioned or unconditioned air to, or removing such air from, any space.

VENTILATION AIR. That portion of supply air that comes from outside (outdoors) plus any recirculated air that has been treated to maintain the desired quality of air within a designated space.

VISIBLE TRANSMITTANCE [VT]. The ratio of visible light entering the space through the fenestration product assembly to the incident visible light. Visible Transmittance includes the effects of glazing material and frame and is expressed as a number between 0 and 1.

WHOLE HOUSE MECHANICAL VENTILATION SYSTEM. An exhaust system, supply system, or combination thereof that is designed to mechanically exchange indoor air with outdoor air when operating continuously or through a programmed intermittent schedule to satisfy the whole house ventilation rates.

ZONE. A space or group of spaces within a *building* with heating or cooling requirements that are sufficiently similar so that desired conditions can be maintained throughout using a single controlling device.

N1101.7 (R301.1) Climate zones. Climate zones from Figure N1101.7 or Table N1101.7 shall be used for determining the applicable requirements in Sections N1101 through N1113. Locations not indicated in Table N1101.7 shall be assigned a climate zone in accordance with Section N1101.7.2.

TABLE N1101.7(R301.1)

NORTH CAROLINA CLIMATE ZONES, MOISTURE REGIMES, AND WARM-HUMID DESIGNATIONS BY COUNTY
CLIMATE ZONES, MOISTURE REGIMES, AND WARM HUMID DESIGNATIONS BY STATE, COUNTY AND TERRITORY^a
NORTH CAROLINA

<u>3A Alamance</u>	<u>3A Forsyth</u>	<u>3A Onslow*</u>
<u>3A Alexander</u>	<u>3A Franklin</u>	<u>3A Orange</u>
<u>5A Alleghany</u>	<u>3A Gaston</u>	<u>3A Pamlico</u>
<u>3A Anson</u>	<u>3A Gates</u>	<u>3A Pasquotank</u>
<u>5A Ashe</u>	<u>4A Graham</u>	<u>3A Pender*</u>

5A Avery	3A Granville	3A Perquimans
3A Beaufort	3A Greene	3A Person
3A Bertie	3A Guilford	3A Pitt
3A Bladen	3A Halifax	3A Polk
3A Brunswick*	3A Harnett	3A Randolph
4A Buncombe	4A Haywood	3A Richmond
4A Burke	4A Henderson	3A Robeson
3A Cabarrus	3A Hertford	3A Rockingham
4A Caldwell	3A Hoke	3A Rowan
3A Camden	3A Hyde	3A Rutherford
3A Carteret*	3A Iredell	3A Sampson
3A Caswell	4A Jackson	3A Scotland
3A Catawba	3A Johnston	3A Stanly
3A Chatham	3A Jones	4A Stokes
3A Cherokee	3A Lee	4A Surry
3A Chowan	3A Lenoir	4A Swain
3A Clay	3A Lincoln	4A Transylvania
3A Cleveland	4A Macon	3A Tyrrell
3A Columbus*	4A Madison	3A Union
3A Craven	3A Martin	3A Vance
3A Cumberland	4A McDowell	3A Wake
3A Currituck	3A Mecklenburg	3A Warren
3A Dare	4A Mitchell	3A Washington
3A Davidson	3A Montgomery	5A Watauga
3A Davie	3A Moore	3A Wayne
3A Duplin	3A Nash	3A 4A Wilkes
3A Durham	3A New Hanover*	3A Wilson
3A Edgecombe	3A Northampton	4A Yadkin
		5A Yancey

a. Key: A – Moist, B – Dry, C – Marine. Absence of moisture designation indicates moisture regime is irrelevant. Asterisk (*) indicates a Warm Humid location.

N1101.7.1 (R301.2) Warm Humid counties. In Table N1101.7, Warm Humid counties are identified by an asterisk.

N1101.7.2 (R301.3) Climate zone definitions. To determine the climate zones for locations not listed in this code, use the following information to determine climate zone numbers and letters in accordance with Items 1 through 5.

1. Determine the thermal climate zone, 0 through 8, from Table N1101.7.2 using the heating (HDD) and cooling degree-days (CDD) for the location.
2. Determine the moisture zone (Marine, Dry or Humid) in accordance with Items 2.1 through 2.3.
 - 2.1. If monthly average temperature and precipitation data are available, use the Marine, Dry and Humid definitions to determine the moisture zone (C, B or A).

2.2. If annual average temperature information (including degree-days) and annual precipitation (i.e., annual mean) are available, use Items 2.2.1 through 2.2.3 to determine the moisture zone. If the moisture zone is not Marine, then use the Dry definition to determine whether Dry or Humid.

2.2.1. If thermal climate zone is 3 and $CDD_{50^{\circ}F} \leq 4,500$ ($CDD_{10^{\circ}C} \leq 2500$), climate zone is Marine (3C).

2.2.2. If thermal climate zone is 4 and $CDD_{50^{\circ}F} \leq 2,700$ ($CDD_{10^{\circ}C} \leq 1500$), climate zone is Marine (4C).

2.2.3. If thermal climate zone is 5 and $CDD_{50^{\circ}F} \leq 1,800$ ($CDD_{10^{\circ}C} \leq 1000$), climate zone is Marine (5C).

2.3. If only degree-day information is available, use Items 2.3.1 through 2.3.3 to determine the moisture zone. If the moisture zone is not Marine, then it is not possible to assign Humid or Dry moisture zone for this location.

2.3.1. If thermal climate zone is 3 and $CDD_{50^{\circ}F} \leq 4,500$ ($CDD_{10^{\circ}C} \leq 2500$), climate zone is Marine (3C).

2.3.2. If thermal climate zone is 4 and $CDD_{50^{\circ}F} \leq 2,700$ ($CDD_{10^{\circ}C} \leq 1500$), climate zone is Marine (4C).

2.3.3. If thermal climate zone is 5 and $CDD_{50^{\circ}F} \leq 1,800$ ($CDD_{10^{\circ}C} \leq 1000$), climate zone is Marine (5C).

3. Marine (C) Zone definition: Locations meeting all of the criteria in Items 3.1 through 3.4.

3.1. Mean temperature of coldest month between $27^{\circ}F$ ($-3^{\circ}C$) and $65^{\circ}F$ ($18^{\circ}C$).

3.2. Warmest month mean $< 72^{\circ}F$ ($22^{\circ}C$).

3.3. Not fewer than four months with mean temperatures over $50^{\circ}F$ ($10^{\circ}C$).

3.4. Dry season in summer. The month with the heaviest precipitation in the cold season has at least three times as much precipitation as the month with the least precipitation in the rest of the year. The cold season is October through March in the Northern Hemisphere and April through September in the Southern Hemisphere.

4. Dry (B) definition: Locations meeting the criteria in Items 4.1 through 4.4.

4.1. Not Marine (C).

4.2. If 70 percent or more of the precipitation, P , occurs during the high sun period, defined as April through September in the Northern Hemisphere and October through March in the Southern Hemisphere, then the dry/humid threshold is in accordance with Equation 11-1.

$$P < 0.44 \times (T - 7)$$
$$[P < 20.0 \times (T + 14) \text{ in SI units}]$$

(Equation 11-1)

where:

P = Annual precipitation, inches (mm).

T = Annual mean temperature, $^{\circ}F$ ($^{\circ}C$).

4.3. If between 30 and 70 percent of the precipitation, P , occurs during the high sun period, defined as April through September in the Northern Hemisphere and October through March in the Southern Hemisphere, then the dry/humid threshold is in accordance with Equation 11-2.

$$P < 0.44 \times (T - 19.5)$$
$$[P < 20.0 \times (T + 7) \text{ in SI units}]$$

(Equation 11-2)

where:

P = Annual precipitation, inches (mm).

T = Annual mean temperature, $^{\circ}F$ ($^{\circ}C$).

4.4. If 30 percent or less of the precipitation, P , occurs during the high sun period, defined as April through September in the Northern Hemisphere and October through March in the Southern Hemisphere, then the dry/humid threshold is in accordance with **Equation 11-3**.

$$P < 0.44 \times (T - 32)$$

$$[P < 20.0 \times T \text{ in SI units}]$$

(Equation 11-3)

where:

P = Annual precipitation, inches (mm).

T = Annual mean temperature, °F (°C).

5. **Humid (A) definition: Locations that are not Marine (C) or Dry (B).** □

TABLE N1101.7.2 (R301.3)
THERMAL CLIMATE ZONE DEFINITIONS

ZONE NUMBER	THERMAL CRITERIA	
	IP Units	SI Units
0	10,800 < CDD50°F	6000 < CDD10°C
1	9,000 < CDD50°F < 10,800	5000 < CDD10°C < 6000
2	6,300 < CDD50°F ≤ 9,000	3500 < CDD10°C ≤ 5000
3	CDD50°F ≤ 6,300 AND HDD65°F ≤ 3,600	CDD10°C ≤ 3500 AND HDD18°C ≤ 2000
4 □	CDD50°F ≤ 6,300 AND 3,600 < HDD65°F ≤ 5,400	CDD10°C ≤ 3500 AND 2000 < HDD18°C ≤ 3000
5	CDD50°F < 6,300 AND 5,400 < HDD65°F ≤ 7,200	CDD10°C < 3500 AND 3000 < HDD18°C ≤ 4000
6	7,200 < HDD65°F ≤ 9,000	4000 < HDD18°C ≤ 5000
7	9,000 < HDD65°F ≤ 12,600	5000 < HDD18°C ≤ 7000
8	12,600 < HDD65°F	7000 < HDD18°C

For SI: °C = [(°F) - 32]/1.8.

N1101.8 (R301.4) Tropical climate region. ~~The tropical climate region shall be defined as:~~ Deleted.

- ~~1. Hawaii, Puerto Rico, Guam, American Samoa, US Virgin Islands, Commonwealth of Northern Mariana Islands; and~~
- ~~2. Islands in the area between the Tropic of Cancer and the Tropic of Capricorn.~~

N1101.9 (R302.1) Interior design conditions. The interior design temperatures used for heating and cooling load calculations shall be a maximum of 72°F (22°C) for heating and minimum of 75°F (24°C) for cooling.

N1101.10 (R303.1) Identification. Materials, systems and equipment shall be identified in a manner that will allow a determination of compliance with the applicable provisions of this code.

N1101.10.1 (R303.1.1) Building thermal envelope insulation. An R -value identification mark shall be applied by the manufacturer to each piece of *building thermal envelope* insulation that is 12 inches (305 mm) or greater in width. Alternatively, the insulation installers shall provide a certification that indicates the type, manufacturer and R -value of insulation installed in each element of the *building thermal envelope*. For blown-in or sprayed fiberglass and cellulose insulation, the initial installed thickness, settled thickness, settled R -value, installed density, coverage area and number of bays installed shall be indicated on the certification. For sprayed polyurethane foam (SPF)

insulation, the installed thickness of the areas covered and the *R*-value of the installed thickness shall be indicated on the certification. For *insulated siding*, the *R*-value shall be on a label on the product's package and shall be indicated on the certification. The insulation installer shall sign, date and post the certification in a conspicuous location on the job site.

Exception: For roof insulation installed above the deck, the *R*-value shall be *labeled* as required by the material standards specified in Table R906.2.

N1101.10.1.1 (R303.1.1.1) Blown-in or sprayed roof and ceiling insulation. The thickness of blown-in or sprayed fiberglass and cellulose roof and ceiling insulation shall be written in inches (mm) on markers that are installed at not less than one for every 300 square feet (28 m²) throughout the attic space. The markers shall be affixed to the trusses or joists and marked with the minimum initial installed thickness with numbers not less than 1 inch (25 mm) in height. Each marker shall face the attic access opening. The thickness and installed *R*-value of sprayed polyurethane foam insulation shall be indicated on the certification provided by the insulation installer.

N1101.10.2 (R303.1.2) Insulation mark installation. Insulating materials shall be installed such that the manufacturer's *R*-value *mark* is readily observable at inspection. For insulation materials that are installed without an observable manufacturer's *R*-value mark, such as blown or draped products, an insulation certificate complying with Section N1101.10.1 shall be left immediately after installation by the installer, in a conspicuous location within the building, to certify the installed *R*-value of the insulation material.

N1101.10.3 (R303.1.3) Fenestration product rating. *U*-factors of fenestration products such as windows, doors and *skylights* shall be determined in accordance with NFRC 100.

Exception: Where required, garage door *U*-factors shall be determined in accordance with either NFRC 100 or ANSI/DASMA 105.

U-factors shall be determined by an accredited, independent laboratory, and *labeled* and certified by the manufacturer.

Products lacking such a *labeled U*-factor shall be assigned a default *U*-factor from Table N1101.10.3(1) or N1101.10.3(2). The *solar heat gain coefficient* (SHGC) and visible transmittance (VT) of glazed fenestration products such as windows, glazed doors and *skylights* shall be determined in accordance with NFRC 200 by an accredited, independent laboratory, and *labeled* and certified by the manufacturer. Products lacking such a *labeled* SHGC or VT shall be assigned a default SHGC or VT from Table N1101.10.3(3).

**TABLE N1101.10.3(1) [R303.1.3(1)]
DEFAULT GLAZED WINDOW,
GLASS DOOR AND SKYLIGHT *U*-FACTORS**

FRAME TYPE	WINDOW AND GLASS DOOR		SKYLIGHT	
	Single pane	Double pane	Single	Double
Metal	1.20	0.80	2.00	1.30
Metal with Thermal Break	1.10	0.65	1.90	1.10
Nonmetal or Metal Clad	0.95	0.55	1.75	1.05
Glazed Block	0.60			

**TABLE N1101.10.3(2) [R303.1.3(2)]
DEFAULT OPAQUE DOOR *U*-FACTORS**

DOOR TYPE	OPAQUE <i>U</i> -FACTOR
Uninsulated Metal	1.20
Insulated Metal	0.60

Wood	0.50
Insulated, nonmetal edge, not exceeding 45% glazing, any glazing double pane	0.35

**TABLE N1101.10.3(3) [R303.1.3(3)]
DEFAULT GLAZED FENESTRATION SHGC AND VT**

	SINGLE GLAZED		DOUBLE GLAZED		GLAZED BLOCK
	Clear	Tinted	Clear	Tinted	
SHGC	0.8	0.7	0.7	0.6	0.6
VT	0.6	0.3	0.6	0.3	0.6

N1101.10.4 (R303.1.4) Insulation product rating. The thermal resistance, *R*-value, of insulation shall be determined in accordance with Part 460 of US-FTC CFR Title 16 in units of $h \times ft^2 \times ^\circ F/Btu$ at a mean temperature of 75°F (24°C).

N1101.10.4.1 (R303.1.4.1) Insulated siding. The thermal resistance, *R*-value, of *insulated siding* shall be determined in accordance with ASTM C1363. Installation for testing shall be in accordance with the manufacturer's instructions.

N1101.10.5 (R303.1.5) Air-impermeable insulation. Insulation having an air permeability not greater than 0.004 cubic feet per minute per square foot [0.002 L/(s × m²)] under pressure differential of 0.3 inch water gauge (75 Pa) when tested in accordance with ASTM E2178 shall be determined air-impermeable insulation.

N1101.11 (R303.2) Installation. Materials, systems and equipment shall be installed in accordance with the manufacturer's instructions and this code.

N1101.11.1 (R303.2.1) Protection of exposed foundation insulation. Insulation applied to the exterior of *basement walls, crawl space* walls and the perimeter of slab-on-grade floors shall have a rigid, opaque and weather-resistant protective covering to prevent the degradation of the insulation's thermal performance. The protective covering shall cover the exposed exterior insulation and extend not less than 6 inches (153 mm) below grade.

N1101.12 (R303.3) Maintenance information. Operations and Maintenance instructions and manuals shall be furnished for equipment and systems that require preventive maintenance. ~~Required regular maintenance actions shall be clearly stated and incorporated on a readily visible label. The label shall include the title or publication number for the operation and maintenance manual for that particular model and type of product.~~

N1101.13 (R401.2) Application. Residential buildings shall comply with Section N1101.13.5 and Section N1101.13.1, N1101.13.2, N1101.13.3 ~~or N1101.13.4, or N1101.13.6.~~

Exception: Additions, alterations, repairs and changes of occupancy to existing buildings complying with Section N1109.

N1101.13.1 (R401.2.1) Prescriptive Compliance Option. The Prescriptive Compliance Option requires compliance with Sections N1101 through N1104.

N1101.13.2 (R401.2.2) Total Building Performance Option. The Total Building Performance Compliance Path requires compliance with Section N1105.

N1101.13.3 (R401.2.3) Energy Rating Index Option. The Energy Rating Index (ERI) option requires compliance with Section N1106.

N1101.13.4 (R401.2.4) Tropical Climate Region Option. ~~The Tropical Climate Region Option requires compliance with Section N1107.~~

N1101.13.5 (R401.2.5) Additional energy efficiency. This section establishes additional requirements applicable to all compliance approaches to achieve additional energy efficiency.

1. For buildings complying with Section N1101.13.1, one of the additional efficiency package options shall be installed according to Section N1108.2.
2. For buildings complying with Section N1101.13.2, the building shall meet one of the following:
 - 2.1. One of the additional efficiency package options in Section N1108.2 shall be installed without including such measures in the proposed design under Section N1105.
 - 2.2. The proposed design of the building under Section N1105.3 shall have an annual energy cost that is less than or equal to 95 percent of the annual energy cost of the standard reference design.
3. For buildings complying with the Energy Rating Index alternative Section N1101.13.3, the Energy Rating Index value shall be at least 5 percent less than the Energy Rating Index target specified.

The option selected for compliance shall be identified on the certificate required by Section N1101.14. *

N1101.14 (R401.3) Certificate. A permanent certificate shall be completed by the builder, permit holder, registered design professional or other *approved* party. ~~and posted on a wall in the space where the furnace is located, a utility room or an approved~~ The permanent certificate shall be posted in a readily accessible location on the electrical distribution panel, in the attic next to the attic insulation card, in a utility room or other approved location inside the *building*. Where located on an electrical panel, the certificate shall not cover or obstruct the visibility of the circuit directory *label*, service disconnect *label* or other required *labels*. The certificate shall indicate the following:

1. The predominant *R*-values of insulation installed in or on ceilings, roofs, walls, foundation components such as slabs, *basement walls, crawl space walls* and floors, and ducts outside *conditioned spaces*.
2. *U*-factors of fenestration and the *solar heat gain coefficient* (SHGC) of fenestration. Where there is more than one value for any component of the building envelope, the certificate shall indicate both the value covering the largest area and the area weighted average value if available.
3. The results from any required duct system and building envelope air leakage testing performed on the building.
4. The types, sizes and efficiencies of heating, cooling and service water-heating equipment. Where a gas-fired unvented room heater, electric furnace, or baseboard electric heater is installed in the residence, the certificate shall indicate “gas-fired unvented room heater,” “electric furnace” or “baseboard electric heater,” as appropriate. An efficiency is not required to be indicated for gas-fired unvented room heaters, electric furnaces and electric baseboard heaters.
5. Where on-site *photovoltaic panel* systems have been installed, the array capacity, inverter efficiency, panel tilt and orientation shall be noted on the certificate.
6. For buildings where an Energy Rating Index score is determined in accordance with Section N1106, the Energy Rating Index score, both with and without any on-site generation, shall be listed on the certificate.
7. The code edition under which the structure was permitted and the compliance path used.

N1101.15 (R401.4) Additional voluntary criteria for increasing residential energy efficiency. Appendix E-4 is a placeholder appendix for adding above-minimum code requirements that can be followed at the discretion of the user.

SECTION N1102 (R402) BUILDING THERMAL ENVELOPE

N1102.1 (R402.1) General. The *building thermal envelope* shall comply with the requirements of Sections N1102.1.1 through N1102.1.5.

Exceptions:

1. The following low-energy *buildings*, or portions thereof, separated from the remainder of the building by *building thermal envelope* assemblies complying with this section shall be exempt from the *building thermal envelope* provisions of Section N1102.

- 1.1. Those with a peak design rate of energy usage less than 3.4 Btu/h × ft² (10.7 W/m²) or 1.0 watt/ft² of floor area for space-conditioning purposes.
- 1.2. Those that do not contain *conditioned space*.

2. Log homes designed in accordance with ICC 400.

3. Deleted.

N1102.1.1 (R402.1.1) Vapor retarder. Wall assemblies in the *building thermal envelope* shall comply with the vapor retarder requirements of Section R702.7.

N1102.1.2 (R402.1.2) Insulation and fenestration criteria. The *building thermal envelope* shall meet the requirements of Table N1102.1.2 based on the *climate zone* specified in Section N1101.7. Assemblies shall have a *U-factor* equal to or less than that specified in Table N1102.1.2. Fenestration shall have a *U-factor* and glazed fenestration SHGC equal to or less than that specified in Table N1102.1.2.

TABLE R1102.1.2 (R402.1.2)
MAXIMUM ASSEMBLY U-FACTORS^a AND FENESTRATION REQUIREMENTS

CLIMATE ZONE	FENESTRATION U-FACTOR ^f	SKYLIGHT U-FACTOR	GLAZED FENESTRATION SHGC ^{d, e}	CEILING U-FACTOR ^g	FRAME WALL U-FACTOR	MASS WALL U-FACTOR ^b	FLOOR U-FACTOR	BASEMENT WALL U-FACTOR	CRAWL SPACE WALL U-FACTOR
0	0.50	0.75	0.25	0.035	0.084	0.197	0.064	0.360	0.477
1	0.50	0.75	0.25	0.035	0.084	0.197	0.064	0.360	0.477
2	0.40	0.65	0.25	-0.026	0.084	0.165	0.064	0.360	0.477
3	0.30	0.55	0.25	0.026	0.060	0.098	0.047	0.091 ^c	0.136
4 except Marine	0.30	0.55	0.40	0.024	0.045	0.098	0.047	0.059	0.065
5 and Marine 4	0.30	0.55	NR	0.024	0.045	0.082	0.033	0.050	0.055
6	0.30	0.55	NR	-0.024	0.045	0.060	0.033	0.050	0.055
7 and 8	0.30	0.55	NR	-0.024	0.045	0.057	0.028	0.050	0.055

For SI: 1 foot = 304.8 mm.

- a. Nonfenestration *U-factors* shall be obtained from measurement, calculation or an approved source.
- b. Mass walls shall be in accordance with Section N1102.2.5. Where more than half the insulation is on the interior, the mass wall *U-factors* shall not exceed 0.17 in Climate Zones 0 and 1, 0.14 in Climate Zone 2, 0.12 in Climate Zone 3, 0.087 in Climate Zone 4 except Marine, 0.065 in Climate Zone 5 and Marine 4, and 0.057 in Climate Zones 6 through 8.
- c. In Warm Humid locations as defined by Figure R301.1 and Table R301.1, the basement wall *U-factor* shall not exceed 0.360.
- d. The SHGC column applies to all glazed fenestration.
Exception: In Climate Zones 0 through 3, skylights shall be permitted to be excluded from glazed fenestration SHGC requirements provided that the SHGC for such skylights does not exceed 0.30.
- e. There are no SHGC requirements in the Marine Zone. Deleted.
- f. A maximum *U-factor* of 0.32 shall apply in Marine Climate Zone 4 and Climate Zones 5 Zone 5 through 8 to vertical fenestration products installed in buildings located either:
 1. Above 4,000 feet in elevation above sea level, or
 2. In windborne debris regions where protection of openings is required by Section R301.2.1.2.
- g. Roofs insulated at the deck (above, below, or combination) shall meet the *U-factors* for the climate zone of the building location.

TABLE N1102.1.3 (R402.1.3)
INSULATION MINIMUM R-VALUES AND FENESTRATION REQUIREMENTS BY COMPONENT^a

CLIMATE ZONE	FENESTRATION U-FACTOR ^{b,i}	SKYLIGHT ^b U-FACTOR	GLAZED FENESTRATION SHGC ^{b,e}	CEILING R-VALUE ⁱ	WOOD FRAME WALL R-VALUE ^g	MASS WALL R-VALUE ^h	FLOOR R-VALUE	BASEMENT ^{c,g} WALL R-VALUE	SLAB ^d R-VALUE & DEPTH	CRAWL SPACE ^{c,g} WALL R-VALUE
0	NR	0.75	0.25	30	13 or 0+10	3/4	13	0	0	0
1	NR	0.75	0.25	30	13 or 0+10	3/4	13	0	0	0
2	0.40	0.65	0.25	49	13 or 0+10	4/6	13	0	0	0
3	0.30	0.55	0.25	49	20 or 13 + 5ci or 0 + 15	8/13	19	5ci or 13 ^f	10ci, 2 ft	5ci or 13 ^f
4 except Marine	0.30	0.55	0.40	60	20 + 5 or 13 + 10ci or 0 + 15	8/13	19	10ci or 13	10ci, 4 ft	10ci or 13
5 and Marine 4	0.30	0.55	0.40	60	20 + 5 or 13 + 10ci or 0 + 15	13/17	30	15ci or 19 or 13 + 5ci	10ci, 4 ft	15ci or 19 or 13 + 5ci
6	0.30	0.55	NR	60	20 + 5ci or 13 + 10ci or 0 + 20	15/20	30	15ci or 19 or 13 + 5ci	10ci, 4 ft	15ci or 19 or 13 + 5ci
7 and 8	0.30	0.55	NR	60	20 + 5ci or 13 + 10ci or 0 + 20	19/21	38	15ci or 19 or 13 + 5ci	10ci, 4 ft	15ci or 19 or 13 + 5ci

For SI: 1 foot = 304.8 mm.

NR = Not Required.

ci = continuous insulation.

a. *R*-values are minimums. *U*-factors and SHGC are maximums. Where insulation is installed in a cavity that is less than the label or design thickness of the insulation, the installed *R*-value of the insulation shall be not less than the *R*-value specified in the table.

b. The fenestration *U*-factor column excludes skylights. The SHGC column applies to all glazed fenestration.

Exception: In Climate Zones 0 through 3, skylights shall be permitted to be excluded from glazed fenestration SHGC requirements provided that the SHGC for such skylights does not exceed 0.30.

c. "5ci or 13" means R-5 continuous insulation (ci) on the interior or exterior surface of the wall or R-13 cavity insulation on the interior side of the wall. "10ci or 13" means R-10 continuous insulation (ci) on the interior or exterior surface of the wall or R-13 cavity insulation on the interior side of the wall. "15ci or 19 or 13 + 5ci" means R-15 continuous insulation (ci) on the interior or exterior surface of the wall; or R-19 cavity insulation on the interior side of the wall; or R-13 cavity insulation on the interior of the wall in addition to R-5 continuous insulation on the interior or exterior surface of the wall.

d. R-5 insulation shall be provided under the full slab area of a heated slab in addition to the required slab edge insulation *R*-value for slabs, as indicated in the table. The slab-edge insulation for heated slabs shall not be required to extend below the slab.

e. There are no SHGC requirements in the Marine Zone.

f. Basement wall insulation shall not be required in Warm Humid locations as defined by Figure N1101.7 and Table N1101.7. □

g. The first value is cavity insulation; the second value is continuous insulation. Therefore, as an example, "13 + 5" means R-13 cavity insulation plus R-5 continuous insulation.

h. Mass walls shall be in accordance with Section N1102.2.5. The second *R*-value applies where more than half of the insulation is on the interior of the mass wall.

i. A maximum *U*-factor of 0.32 shall apply in Climate Zones 3 through 8 Zone 5 to vertical fenestration products installed in buildings located either:

1. Above 4,000 feet in elevation, or

2. In windborne debris regions where protection of openings is required by Section R301.2.1.2.

j. Roofs insulated at the deck (above, below, or combination) shall meet the *U*-factors in Table 1102.1.2.

N1102.1.3 (R402.1.3) *R*-value alternative. Assemblies with *R*-value of insulation materials equal to or greater than that specified in Table N1102.1.3 shall be an alternative to the *U*-factor in Table N1102.1.2. □

N1102.1.4 (R402.1.4) *R*-value computation. Cavity insulation alone shall be used to determine compliance with the cavity insulation *R*-value requirements in Table N1102.1.3. Where cavity insulation is installed in multiple layers, the *R*-values of the cavity insulation layers shall be summed to determine compliance with the cavity

insulation *R*-value requirements. The manufacturer's settled *R*-value shall be used for blown-in insulation. Continuous insulation (ci) alone shall be used to determine compliance with the continuous insulation *R*-value requirements in Table N1102.1.3. Where continuous insulation is installed in multiple layers, the *R*-values of the continuous insulation layers shall be summed to determine compliance with the continuous insulation *R*-value requirements. Cavity insulation *R*-values shall not be used to determine compliance with the continuous insulation *R*-value requirements in Table N1102.1.3. Computed *R*-values shall not include an *R*-value for other building materials or air films. Where *insulated siding* is used for the purpose of complying with the continuous insulation requirements of Table N1102.1.3, the manufacturer's *labeled R*-value for *insulated siding* shall be reduced by R-0.6.

N1102.1.5 (R402.1.5) Total UA alternative. Where the total *building thermal envelope* UA, the sum of *U*-factor times assembly area, is less than or equal to the total UA resulting from multiplying the *U*-factors in Table N1102.1.2 by the same assembly area as in the proposed *building*, the *building* shall be considered to be in compliance with Table N1102.1.2. The UA calculation shall be performed using a method consistent with the ASHRAE *Handbook of Fundamentals* and shall include the thermal bridging effects of framing materials. In addition to UA compliance, the SHGC requirements of Table N1102.1.2 and the maximum fenestration *U*-factors of Section N1102.5 shall be met.

REScheck Option. North Carolina approved version of REScheck shall be permitted to demonstrate compliance with this code. Envelope requirements may not be traded off against the use of high efficiency heating or cooling equipment. No tradeoff calculations are needed for required termite inspection and treatment gaps.

N1101.1.6 Rooms containing fuel-burning appliances. In Climate Zones 3 through 8-5, where open combustion air ducts provide combustion air to open combustion fuel burning appliances, the appliances and combustion air opening shall be located outside the building thermal envelope or enclosed in a room that is isolated from inside the thermal envelope. Such rooms shall be sealed and insulated in accordance with the envelope requirements of Table R402.1.3, where the walls, floors and ceilings shall meet a minimum of the basement wall *R*-value requirement. The door into the room shall be fully gasketed and any water lines and ducts in the room insulated in accordance with Section R403. The combustion air duct shall be insulated where it passes through conditioned space to an *R*-value of not less than R-8.

Exceptions:

1. Direct vent appliances with both intake and exhaust pipes installed continuous to the outside.
2. Fireplaces and stoves complying with Section N1102.4.2 and Section R1006 of the International Residential Code.

N1102.2 (R402.2) Specific insulation requirements. In addition to the requirements of Section N1102.1, insulation shall meet the specific requirements of Sections N1102.2.1 through N1102.2.12.

N1102.2.1 (R402.2.1) Ceilings with attic spaces. Where Section N1102.1.3 requires R-49 insulation in the ceiling or attic, installing R-38 insulation over 100 percent of the ceiling or attic area requiring insulation shall satisfy the requirement for R-49 insulation wherever the full height of uncompressed R-38 insulation extends over the wall top plate at the eaves. Where Section N1102.1.2 requires R-60 insulation in the ceiling, installing R-49 over 100 percent of the ceiling area requiring insulation shall satisfy the requirement for R-60 insulation wherever the full height of uncompressed R-49 insulation extends over the wall top plate at the eaves. This reduction shall not apply to the insulation and fenestration criteria in Section N1102.1.2 and the Total UA alternative in Section N1102.1.5.

Exception. In other details such as bay window and dormer roofs, and similar areas where the space is limited, the available space shall be filled with insulation for unvented details, and to the insulation baffle for vented assemblies.

N1102.2.2 (R402.2.2) Ceilings without attics. Where Section N1102.1.3 requires insulation *R*-values greater than R-30 in the interstitial space above a ceiling and below the structural roof deck, and the design of the roof/ceiling assembly, including cathedral ceilings, dormers, bay windows and other similar areas, does not allow sufficient space for the required insulation, the minimum required insulation *R*-value for such roof/ceiling assemblies shall be R-30. Insulation shall extend over the top of the wall plate to the outer edge of such plate and shall not be compressed. This reduction of insulation from the requirements of Section N1102.1.3 shall be limited to 500 square

feet (46 m²) or 20 percent of the total insulated ceiling area, whichever is less. This reduction shall not apply to the Total UA alternative in Section N1102.1.5.

N1102.2.3 (R402.2.3) Eave Soffit baffle. For air-permeable insulation in vented attics, a baffle shall be installed adjacent to soffit and eave vents. Baffles shall maintain a net free area opening equal to or greater than the size of the vent. The baffle shall extend over the top of the attic insulation. The baffle shall be permitted to be any solid material. The baffle shall be installed to the outer edge of the exterior wall top plate so as to provide maximum space for attic insulation coverage over the top plate. Where soffit venting is not continuous, baffles shall be installed continuously to prevent ventilation air in the eave / soffit from bypassing the baffle.

N1102.2.4 (R402.2.4) Access hatches and doors. Access hatches and doors from conditioned to unconditioned spaces such as attics and crawl spaces shall be insulated to the same R-value required by Table N1102.1.3 for the wall or ceiling in which they are installed.

Exceptions:

1. Vertical doors providing access from conditioned spaces to unconditioned spaces that comply with the fenestration requirements of Table N1102.1.3 based on the applicable climate zone specified in Chapter 3.
2. Horizontal pull-down, stair-type access hatches in ceiling assemblies that provide access from conditioned to unconditioned spaces in Climate Zones 0 through 4, 3.4, & 5 shall not be required to comply with the insulation level of the surrounding surfaces provided that the hatch meets all of the following:
 - 2.1. The average *U*-factor of the hatch shall be less than or equal to U-0.10 or have an average insulation *R*-value of R-10 or greater.
 - 2.2. Not less than 75 percent of the panel area shall have an insulation *R*-value of R-13 or greater.
 - 2.3. The net area of the framed opening shall be less than or equal to 13.5 square feet (1.25 m²).
 - 2.4. The perimeter of the hatch edge shall be weatherstripped.

The reduction shall not apply to the total UA alternative in Section N1102.1.5.

N1102.2.4.1 (R402.2.4.1) Access hatch and door insulation installation and retention. Vertical or horizontal access hatches and doors from *conditioned spaces* to *unconditioned spaces* such as attics and crawl spaces shall be weatherstripped. Access that prevents damaging or compressing the insulation shall be provided to all equipment. Where loose-fill insulation is installed, a wood-framed or equivalent baffle or retainer, or dam shall be installed to prevent loose-fill insulation from spilling into living spaces, from higher to lower sections of the attic, and from attics covering conditioned spaces to unconditioned spaces. The baffle or retainer shall provide a permanent means of maintaining the installed *R*-value of the loose-fill insulation. □

N1102.2.5 (R402.2.5) Mass walls. Mass walls for the purposes of this chapter shall be considered walls of concrete block, concrete, insulated concrete form (ICF), masonry cavity, brick (other than brick veneer), earth (adobe, compressed earth block, rammed earth) and solid timber/logs, or any other walls meeting the following:

- Masonry or concrete walls having a mass greater than or equal to 30 pounds per square foot (146 kg/m²).
- Solid wood walls having a mass greater than 20 pounds per square foot (98 kg/m²).
- Any walls having a heat capacity greater than or equal to 6 Btu/ft² · °F [266 J/(m² · K)].

Mass walls where used as a component of the *building thermal envelope* shall be one of the following:

1. ~~Above ground walls of concrete block, concrete, insulated concrete form, masonry cavity, brick but not brick veneer, adobe, compressed earth block, rammed earth, solid timber, mass timber or solid logs.~~
2. ~~Any wall having a heat capacity greater than or equal to 6 Btu/ft² · °F (123 kJ/m² · K).~~

N1102.2.6 (R402.2.6) Steel-frame ceilings, walls, and floors. Steel-frame ceilings, walls, and floors shall comply with the insulation requirements of Table N1102.2.6 or the *U*-factor requirements of Table N1102.1.2. The calculation of the *U*-factor for a steel-frame envelope assembly shall use a series-parallel path calculation method. □

TABLE N1102.2.6 (R402.2.6)
STEEL-FRAME CEILING, WALL AND FLOOR INSULATION R-VALUES

WOOD FRAME R-VALUE REQUIREMENT	COLD-FORMED STEEL-FRAME EQUIVALENT R-VALUE ^a
Steel Truss Ceilings ^b	
R-30	R-38 or R-30 + 3 or R-26 + 5
R-38	R-49 or R-38 + 3
R-49	R-38 + 5
Steel Joist Ceilings ^b	
R-30	R-38 in 2 × 4 or 2 × 6 or 2 × 8 R-49 in any framing
R-38	R-49 in 2 × 4 or 2 × 6 or 2 × 8 or 2 × 10
Steel-frame Wall, 16 inches on center	
R-13	R-13 + 4.2 or R-21 + 2.8 or R-0 + 9.3 or R-15 + 3.8 or R-21 + 3.1 □
R-13 + 5	R-0 + 15 or R-13 + 9 or R-15 + 8.5 or R-19 + 8 or R-21 + 7
R-13 + 10	R-0 + 20 or R-13 + 15 or R-15 + 14 or R-19 + 13 or R-21 + 13
R-20	R-0 + 14.0 or R-13 + 8.9 or R-15 + 8.5 or R-19 + 7.8 or R-21 + 7.5
R-20 + 5	R-13 + 12.7 or R-15 + 12.3 or R-19 + 11.6 or R-21 + 11.3 or R-25 + 10.9
R-21	R-0 + 14.6 or R-13 + 9.5 or R-15 + 9.1 or R-19 + 8.4 or R-21 + 8.1 or R-25 + 7.7
Steel-frame Wall, 24 inches on center	
R-13	R-0 + 9.3 or R-13 + 3.0 or R-15 + 2.4 □
R-13 + 5	R-0 + 15 or R-13 + 7.5 or R-15 + 7 or R-19 + 6 or R-21 + 6
R-13 + 10	R-0 + 20 or R-13 + 13 or R-15 + 12 or R-19 + 11 or R-21 + 11
R-20	R-0 + 14.0 or R-13 + 7.7 or R-15 + 7.1 or R-19 + 6.3 or R-21 + 5.9
R-20 + 5	R-13 + 11.5 or R-15 + 10.9 or R-19 + 10.1 or R-21 + 9.7 or R-25 + 9.1
R-21	R-0 + 14.6 or R-13 + 8.3 or R-15 + 7.7 or R-19 + 6.9 or R-21 + 6.5 or R-25 + 5.9
Steel Joist Floor	
R-13	R-19 in 2 × 6, or R-19 + 6 in 2 × 8 or 2 × 10
R-19	R-19 + 6 in 2 × 6, or R-19 + 12 in 2 × 8 or 2 × 10

For SI: 1 inch = 25.4 mm.

- The first value is cavity insulation *R*-value; the second value is continuous insulation *R*-value. Therefore, for example, “R-30 + 3” means R-30 cavity insulation plus R-3 continuous insulation.
- Insulation exceeding the height of the framing shall cover the framing.

N1102.2.7 (R402.2.7) Floors. Floor *cavity* insulation shall comply with one of the following:

1. Insulation shall be installed to maintain permanent contact with the underside of the subfloor decking in accordance with manufacturer instructions to maintain required *R*-value or readily fill the available cavity space. The distance between tension support wires or other devices that hold the floor insulation in place against the subfloor shall be no more than 18 inches. In addition, supports shall be located no further than 6 inches from each end of the insulation.
2. Floor framing cavity insulation shall be permitted to be in contact with the top side of sheathing/gypsum separating the cavity and the unconditioned space below. Insulation shall extend from the bottom to the top of all perimeter floor framing members (the band boards) and the framing members shall be air sealed.
3. A combination of cavity and continuous insulation shall be installed so that the cavity insulation is in contact with the top side of the continuous insulation that is installed on the underside of the floor framing separating the cavity and the unconditioned space below. The combined *R*-value of the cavity and continuous insulation shall equal the required *R*-value for floors. Insulation shall extend from the bottom to the top of all perimeter floor framing members and the framing members shall be air sealed. □

N1102.2.8 (R402.2.8) Basement walls. *Basement walls* shall be insulated in accordance with Table N1102.1.3.

Exception: Basement walls associated with unconditioned basements where all of the following requirements are met:

1. The floor overhead, including the underside stairway stringer leading to the basement, is insulated in accordance with Section N1102.1.3 and applicable provisions of Sections N1102.2 and N1102.2.7.
2. There are no uninsulated duct, domestic hot water or hydronic heating surfaces exposed to the basement.
3. There are no HVAC supply or return diffusers serving the basement.
4. The walls surrounding the stairway and adjacent to conditioned space are insulated in accordance with Section N1102.1.3 and applicable provisions of Section N1102.2.
5. The door(s) leading to the basement from conditioned spaces are insulated in accordance with Section N1102.1.3 and applicable provisions of Section N1102.2, and weatherstripped in accordance with Section N1102.4.
6. The building thermal envelope separating the basement from adjacent conditioned spaces complies with Section N1102.4.

N1102.2.8.1 (R402.2.8.1) Basement wall insulation installation. Where basement walls are insulated, the insulation shall be installed from the top of the *basement wall* down to 10 feet (3048 mm) below grade or to the basement floor, whichever is less. Foam plastic insulation applied to exterior of basement walls shall be provided with termite inspection and treatment gaps in accordance with Appendix O (Appendix R2).

Dan to add back Appendix R2 details from 2018 code to 2024 code.

N1102.2.9 (R402.2.9) Slab-on-grade floors. Slab-on-grade floors with a floor surface less than 12 inches (305 mm) below grade shall be insulated in accordance with Table N1102.1.3.

Exception: ~~Slab edge insulation is not required in jurisdictions designated by the code official as having a very heavy termite infestation.~~ Deleted

N1102.2.9.1 (R402.2.9.1) Slab-on-grade floor insulation installation. Where installed, the insulation shall extend downward from the top of the slab on the outside or inside of the foundation wall. Insulation located below grade shall extend the distance provided in Table N1102.1.3 or the distance of the proposed design, as applicable, by any combination of vertical insulation, insulation extending under the slab or insulation extending out from the building. Insulation extending away from the building shall be protected by pavement or by not less than 10 inches (254 mm)

of soil. The top edge of the insulation installed between the exterior wall and the edge of the interior slab shall be permitted to be cut at a 45-degree (0.79 rad) angle away from the exterior wall. Slab edge insulation shall have a 2-inch termite inspection gap consistent with Appendix O (Appendix R2) of this code.

N1102.2.10 (R402.2.10) Crawl space walls. Crawl space walls shall be insulated in accordance with Table N1102.1.3.

Exception: Crawl space walls associated with a crawl space that is vented to the outdoors and the floor overhead is insulated in accordance with Table N1102.1.3 and Section N1102.2.7.

N1102.2.10.1 (R402.2.10.1) Crawl space wall insulation installation. Where crawl space wall insulation is installed, it shall be permanently fastened to the wall and shall extend downward from the floor to the finished grade elevation and then vertically or horizontally for not less than an additional 24 inches (610 mm). Exposed earth in unvented crawl space foundations shall be covered with a continuous Class I vapor retarder in accordance with this code. Joints of the vapor retarder shall overlap by 6 inches (153 mm) and be sealed or taped. The edges of the vapor retarder shall extend not less than 6 inches (153 mm) up the stem walls and shall be attached to the stem walls.

Wall insulation may be located in any combination of the outside and inside wall surfaces and within the structural cavities or materials of the wall system. Wall insulation requires that the exterior wall band joist area of the floor frame be insulated. Wall insulation shall begin 3 inches (76.2 mm) below the top of the masonry foundation wall and shall extend down to 3 inches (76.2 mm) above the top of the footing or concrete floor, 3 inches (76.2 mm) above the interior ground surface or 24 inches (609.6 mm) below the outside finished ground level, whichever is less. (See Appendix E details).

Termite inspection, clearance, and wicking gaps are allowed in wall insulation systems. Insulation may be omitted in the gap area without energy penalty. The allowable insulation gap widths are listed in Table N1102.2.10.1 (Table R402.2.11). If gap width exceeds the allowances, one of the following energy compliance options shall be met:

1. Wall insulation is not allowed and the required insulation value shall be provided in the floor system.
2. Compliance shall be demonstrated with energy trade-off methods provided by the UA Alternative method or Section N1102.1.5 (R405).

TABLE N1102.2.10.1
WALL INSULATION ALLOWANCES FOR TERMITE
TREATMENT AND INSULATION GAPS

GAP WIDTH (inches)		INSULATION LOCATION	GAP DESCRIPTION
Minimum	Maximum		
2	3	Outside	<u>Above grade inspection between top of insulation and bottom of siding</u>
4	6	Outside	<u>Below grade treatment</u>
3 ^a	4 ^a	Inside	<u>Wall inspection between top of insulation and bottom of sill</u>
3 ^a	4 ^a	Inside	<u>Clearance/wicking space between bottom of insulation and top of ground surface, footing, or concrete floor</u>

a. No insulation shall be required on masonry walls of 9 inches in height or less.

N1102.2.11 (R402.2.11) Masonry veneer. Insulation shall not be required on the horizontal portion of a foundation that supports a masonry veneer.

N1102.2.12 (R402.2.12) Sunroom and heated garage insulation. Sunrooms enclosing conditioned space and heated garages shall meet the insulation requirements of this code.

Exception: For *sunrooms* and heated garages provided with *thermal isolation*, and enclosing *conditioned space*, the following exceptions to the insulation *requirements* of this code shall apply:

1. The minimum ceiling insulation *R*-values shall be R-19 in *Climate Zones 0 through 3 and 4* and R-24 in Climate ~~*Zone 5. Zones 5 through 8.*~~
2. The minimum wall insulation *R*-value shall be R-13 in all climate zones. Walls separating a *sunroom* or *heated garage* with *thermal isolation* from *conditioned space* shall comply with the *building thermal envelope* requirements of this code.

N1102.3 (R402.3) Fenestration. In addition to the requirements of Section N1102, fenestration shall comply with Sections N1102.3.1 through N1102.3.5.

N1102.3.1 (R402.3.1) U-factor. An area-weighted average of fenestration products shall be permitted to satisfy the *U*-factor requirements.

N1102.3.2 (R402.3.2) Glazed fenestration SHGC. An area-weighted average of fenestration products more than 50-percent glazed shall be permitted to satisfy the SHGC requirements.

Dynamic glazing shall be permitted to satisfy the SHGC requirements of Table N1102.1.2 provided that the ratio of the higher to lower *labeled* SHGC is greater than or equal to 2.4, and the dynamic glazing is automatically controlled to modulate the amount of solar gain into the space in multiple steps. Dynamic glazing shall be considered separately from other fenestration, and area-weighted averaging with other fenestration that is not dynamic glazing shall be prohibited.

Exception: Dynamic glazing shall not be required to comply with this section where both the lower and higher *labeled* SHGC comply with the requirements of Table N1102.1.2.

N1102.3.3 (R402.3.3) Glazed fenestration exemption. Not greater than 15 square feet (1.4 m²) of glazed fenestration per *dwelling unit* shall be exempt from the *U*-factor and SHGC requirements in Section N1102.1.2. This exemption shall not apply to the Total UA alternative in Section N1102.1.5.

N1102.3.4 (R402.3.4) Opaque door exemption. One side-hinged opaque door assembly not greater than 24 square feet (2.22 m²) in area shall be exempt from the *U*-factor requirement in Section N1102.1.2. This exemption shall not apply to the and the Total UA alternative in Section N1102.1.5.

N1102.3.5 (R402.3.5) Sunroom and heated garage fenestration. *Sunrooms* and *heated garages* enclosing *conditioned space* shall comply with the fenestration requirements of this code.

Exception: In Climate Zones ~~*2 3*~~ through ~~*5, 8*~~, for *sunrooms* and *heated garages* with *thermal isolation* and enclosing *conditioned space*, the fenestration *U*-factor shall not exceed 0.45 and the skylight *U*-factor shall not exceed 0.70.

New fenestration separating a *sunroom* or *heated garages* with *thermal isolation* from *conditioned space* shall comply with the *building thermal envelope* requirements of this code.

N1102.4 (R402.4) Air leakage. The *building thermal envelope* shall be constructed to limit air leakage in accordance with the requirements of Sections N1102.4.1 through N1102.4.5.

N1102.4.1 (R402.4.1) Building thermal envelope air leakage. The *building thermal envelope* shall comply with Sections N1102.4.1.1 through N1102.4.1.3. The sealing methods between dissimilar materials shall allow for differential expansion and contraction.

N1102.4.1.1 (R402.4.1.1) Installation. The components of the *building thermal envelope* as indicated in Table N1102.4.1.1 shall be installed in accordance with the manufacturer's instructions and the criteria indicated in Table N1102.4.1.1, as applicable to the method of construction. Where required by the *code official*, an *approved* third party shall inspect all components and verify compliance.

TABLE N1102.4.1.1 (R402.4.1.1)
AIR BARRIER, AIR SEALING AND INSULATION INSTALLATION^a

COMPONENT	AIR BARRIER CRITERIA	INSULATION INSTALLATION CRITERIA
General requirements	A continuous air barrier shall be installed in the building envelope. Breaks or joints in the air barrier shall be sealed.	Air-permeable insulation shall not be used as a sealing material.

Ceiling/attic	<p>The air barrier in any dropped ceiling or soffit shall be aligned with the insulation and any gaps in the air barrier shall be sealed.</p> <p>Access openings, drop-down stairs or knee wall doors to unconditioned attic spaces shall be sealed.</p>	The insulation in any dropped ceiling/soffit shall be aligned with the air barrier.
Walls	<p>The junction of the foundation and sill plate shall be sealed.</p> <p>The junction of the top plate and the top of exterior walls shall be sealed.</p> <p>Knee walls shall be sealed.</p>	Cavities within corners and headers of frame walls shall be insulated by completely filling the cavity with a material having a thermal resistance, <i>R</i> -value, of not less than <i>R</i> -3 per inch. Exterior thermal envelope insulation for framed walls shall be installed in substantial contact and continuous alignment with the air barrier.
Windows, skylights and doors	The space between framing and skylights, and the jambs of windows and doors, shall be sealed.	—
Rim joists	<p>Rim joists shall include an exterior air barrier.^b</p> <p>The junctions of the rim board to the sill plate and the rim board and the subfloor shall be air sealed.</p>	Rim joists shall be insulated so that the insulation maintains permanent contact with the exterior rim board. ^b
Floors, including cantilevered floors and floors above garages	The air barrier shall be installed at any exposed edge of insulation.	Floor framing cavity insulation shall be installed to maintain permanent contact with the underside of subfloor decking. Alternatively, floor framing cavity insulation shall be in contact with the top side of sheathing, or continuous insulation installed on the underside of floor framing and extending from the bottom to the top of all perimeter floor framing members.
Basement crawl space, and slab foundations	<p>Exposed earth in unvented crawl spaces shall be covered with a Class I vapor retarder/air barrier in accordance with Section R402.2.10.</p> <p>Penetrations through concrete foundation walls and slabs shall be air sealed.</p> <p>Class 1 vapor retarders shall not be used as an air barrier on below-grade walls and shall be installed in accordance with Section R702.7.</p>	<p>Crawl space insulation, where provided instead of floor insulation, shall be installed in accordance with Section R402.2.10.</p> <p>Conditioned basement foundation wall insulation shall be installed in accordance with Section R402.2.8.1.</p> <p>Slab-on-grade floor insulation shall be installed in accordance with Section R402.2.10.</p>
Shafts, penetrations	<p>Duct and flue shafts and other similar penetrations to exterior or unconditioned space shall be sealed to allow for expansion, contraction and mechanical vibration.</p> <p>Utility penetrations of the air barrier shall be caulked, gasketed or otherwise sealed and shall allow for expansion, contraction of materials and mechanical vibration.</p>	Insulation shall be fitted tightly around utilities passing through shafts and penetrations in the building thermal envelope to maintain required <i>R</i> -value.
Narrow cavities	Narrow cavities of 1 inch or less that are not able to be insulated shall be air sealed.	Batts to be installed in narrow cavities shall be cut to fit or narrow cavities shall be filled with insulation that on installation readily conforms to the available cavity space.
Garage separation	Air sealing shall be provided between the garage and conditioned spaces.	Insulated portions of the garage separation assembly shall be installed in accordance with Sections R303 and R402.2.7.

(continued)

TABLE N1102.4.1.1 (R402.4.1.1)—continued
AIR BARRIER AND INSULATION INSTALLATION^a

COMPONENT	AIR BARRIER CRITERIA	INSULATION INSTALLATION CRITERIA
Recessed lighting	Recessed light fixtures installed in the building thermal envelope shall be air sealed in accordance with Section R402.4.5.	Recessed light fixtures installed in the building thermal envelope shall be airtight and IC rated, and shall be buried or surrounded with insulation.
Plumbing, wiring or other obstructions	All holes created by wiring, plumbing or other obstructions in the air barrier assembly shall be air sealed.	Insulation shall be installed to fill the available space and surround wiring, plumbing, or other obstructions, unless the required R-value can be met by installing insulation and air barrier systems completely to the exterior side of the obstructions.
Shower/tub on exterior wall	The air barrier installed at exterior walls adjacent to showers and tubs shall separate the wall from the shower or tub.	Exterior walls adjacent to showers and tubs shall be insulated.
Electrical/phone box on exterior walls	The air barrier shall be installed behind electrical and communication boxes. Alternatively, air-sealed boxes shall be installed.	—
HVAC register boots	HVAC supply and return register boots that penetrate building thermal envelope shall be sealed to the subfloor, wall covering or ceiling penetrated by the boot.	—
Concealed sprinklers	Where required to be sealed, concealed fire sprinklers shall only be sealed in a manner that is recommended by the manufacturer. Caulking or other adhesive sealants shall not be used to fill voids between fire sprinkler cover plates and walls or ceilings.	—

For SI: 1 inch = 25.4 mm.

a. Inspection of log walls shall be in accordance with the provisions of ICC 400.

b. Air barrier and insulation full enclosure is not required in unconditioned/ventilated attic spaces and at rim joists.

N1102.4.1.2 (R402.4.1.2) Testing. The *building* or *dwelling unit* shall be tested for air leakage. The maximum air leakage rate for any *building* or *dwelling unit* under any compliance path shall not exceed ~~5.0~~ **4.0** air changes per hour or ~~0.28~~ **0.23** cubic feet per minute (CFM) per square foot [0.0079 m³/(s × m²)] of dwelling unit enclosure area. Testing shall be conducted in accordance with ANSI/RESNET/ICC 380, ASTM E779, ASTM E3158 or ASTM E1827 and reported at a pressure of 0.2 inch w.g. (50 Pascals). Alternately, if using a higher test pressure of 0.30 in. w.g. (75 Pa), a maximum air leakage rate of 0.30 cubic feet per minute per square foot of dwelling unit enclosure area shall be met. Where required by the *code official*, testing shall be conducted by an *approved* third party. A written report of the results of the test shall be signed by the party conducting the test and provided to the *code official*. Testing shall be performed at any time after creation of all penetrations of the *building thermal envelope* have been sealed.

Exception: For heated, attached private garages and heated, detached private garages accessory to one- and two-family dwellings and townhouses not more than three stories above *grade plane* in height, building envelope tightness and insulation installation shall be considered acceptable where the items in Table N1102.4.1.1, applicable to the method of construction, are field verified. Where required by the code official, an *approved* third party independent from the installer shall inspect both air barrier and insulation installation criteria. Heated, attached private garage space and heated, detached private garage space shall be thermally isolated from all other *conditioned spaces* in accordance with Sections N1102.2.12 and N1102.3.5, as applicable.

During testing:

1. Exterior windows and doors, fireplace and stove doors shall be closed, but not sealed, beyond the intended weatherstripping or other infiltration control measures.
2. Dampers including exhaust, intake, makeup air, backdraft and flue dampers shall be closed, but not sealed beyond intended infiltration control measures.
3. Interior doors, where installed at the time of the test, shall be open.
4. Exterior or interior terminations for continuous ventilation systems shall be sealed.
5. Heating and cooling systems, where installed at the time of the test, shall be turned off.
6. Supply and return registers, where installed at the time of the test, shall be fully open.

Exception: ~~When testing individual dwelling units, an air leakage rate not exceeding 0.30 cubic feet per minute per square foot [0.008 m³/(s × m²)] of the dwelling unit enclosure area, tested in accordance with ANSI/RESNET/ICC 380, ASTM E779 or ASTM E1827 and reported at a pressure of 0.2 inch water gauge (50 Pa), shall be permitted in all climate zones for:~~

- ~~1. Attached single and multiple family building dwelling units.~~
- ~~2. Buildings or dwelling units that are 1,500 square feet (139.4 m²) or smaller.~~

Exceptions:

1. When testing individual dwelling units, an air leakage rate not exceeding 0.30 cubic feet per minute per square foot [0.008 m³/(s × m²)] of the dwelling unit enclosure area, tested in accordance with ANSI/RESNET/ICC 380, ASTM E779 or ASTM E1827 and reported at a pressure of 0.2 inch w.g. (50 Pa), shall be an accepted alternative permitted in all climate zones for:
 - a. Attached single and multiple family building dwelling units.
 - b. Buildings or dwelling units that are 1,500 square feet (139.4 m²) or smaller.
2. For heated, attached private garages and heated, detached private garages accessory to one and two-family dwellings and townhouses not more than three stories above grade plane in height, building envelope tightness and insulation installation shall be considered acceptable where the items in Table R402.4.1.1, applicable to the method of construction, are field verified. Where required by the code official, an approved third party independent from the installer shall inspect both air barrier and insulation installation criteria. Heated, attached private garage space and heated, detached private garage space shall be thermally isolated from all other habitable, conditioned spaces in accordance with Sections R402.2.12 and R402.3.5, as applicable.

Mechanical *ventilation* shall be provided in accordance with Section M1505 of this code or Section 403.3.2 of the *International Mechanical Code*, as applicable, or with other *approved* means of *ventilation*.

N1102.4.1.3 (R402.4.1.3) Leakage rate. Where complying with Section N1101.13.1, the building or *dwelling unit* shall have an air leakage rate not exceeding ~~5.0 air changes per hour in Climate Zones 0, 1 and 2, and~~ 3.0 air changes per hour in Climate Zones 3 through ~~8, 5,~~ when tested in accordance with Section N1102.4.1.2.

N1102.4.2 (R402.4.2) Fireplaces. New wood-burning fireplaces shall have tight-fitting flue dampers or doors, and outdoor combustion air. Where using tight-fitting doors on factory-built fireplaces *listed* and *labeled* in accordance with UL 127, the doors shall be tested and *listed* for the fireplace.

N1102.4.3 (R402.4.3) Fenestration air leakage. Windows, *skylights* and sliding glass doors shall have an air infiltration rate of not greater than 0.3 cfm per square foot (1.5 L/s/m²), and for swinging doors not greater than 0.5 cfm per square foot (2.6 L/s/m²), when tested in accordance with NFRC 400 or AAMA/WDMA/CSA 101/I.S.2/A440 by an accredited, independent laboratory and *listed* and *labeled* by the manufacturer.

Exception: Site-built windows, *skylights* and doors.

~~N1102.4.4 (R402.4.4) Rooms containing fuel-burning appliances. In Climate Zones 3 through 8, 5 where opencombustion airducts provide combustion air to open combustion fuel-burning appliances, the appliances and combustion air opening shall be located outside the **building thermal envelope** or enclosed in a room that is isolated from inside the thermal envelope. Such rooms shall be sealed and insulated in accordance with the envelope requirements of Table N1102.1.3, where the walls, floors and ceilings shall meet a minimum of the **basement wall R-value** requirement. The door into the room shall be fully gasketed and any water lines and ducts in the room insulated in accordance with Section N1103. The combustion air duct shall be insulated where it passes through **conditioned space** to an **R-value** of not less than **R-8**.~~

Exceptions:

- ~~1.—Direct vent appliances with both intake and exhaust pipes installed continuous to the outside.~~
- ~~2.—Fireplaces and stoves complying with Sections N1102.4.2 and R1006.~~

N1102.4.5 (R402.4.5) N1102.4.4 (R402.4.5) Recessed lighting. Recessed luminaires installed in the **building thermal envelope** shall be sealed to limit air leakage between conditioned and **unconditioned spaces**. Recessed luminaires shall be IC-rated and **labeled** as having an air leakage rate of not greater than 2.0 cfm (0.944 L/s) when tested in accordance with ASTM E283 at a pressure differential of 1.57 psf (75 Pa). Recessed luminaires shall be sealed with a gasket or caulked between the housing and the interior wall or ceiling covering.

N1102.4.6 (R402.4.6) N1102.4.5 (R402.4.5) Electrical and communication outlet boxes (air-sealed boxes). Electrical and communication outlet boxes installed in the building thermal envelope shall be sealed to limit air leakage between conditioned and unconditioned spaces. Electrical and communication outlet boxes shall be tested in accordance with NEMA OS 4, Requirements for Air-Sealed Boxes for Electrical and Communication Applications, and shall have an air leakage rate of not greater than 2.0 cubic feet per minute (0.944 L/s) at a pressure differential of 1.57 psf (75 Pa). Electrical and communication outlet boxes shall be marked “NEMA OS 4” or “OS 4” in accordance with NEMA OS 4. Electrical and communication outlet boxes shall be installed per the manufacturer’s instructions and with any supplied components required to achieve compliance with NEMA OS 4.

N1102.5 (R402.5) Maximum fenestration U-factor and SHGC. The area-weighted average maximum fenestration **U-factor** permitted using tradeoffs from Section N1102.1.5 or N1105 shall be 0.48 in Climate Zones 4 and 5 ~~and 0.40 in Climate Zones 6 through 8~~ for vertical fenestration, and 0.75 in Climate Zones 4 through 8 ~~5~~ for **skylights**. The area-weighted average maximum fenestration SHGC permitted using tradeoffs from Section N1105 in Climates ~~4 through 3~~ shall be **0.40**.

Exception: The maximum U-factor and solar heat gain coefficient (SHGC) for fenestration shall not be required in storm shelters complying with ICC 500.

SECTION N1103 (R403) SYSTEMS

N1103.1 (R403.1) Controls. Not less than one thermostat shall be provided for each separate heating and cooling system.

N1103.1.1 (R403.1.1) Programmable thermostat. The thermostat controlling the primary heating or cooling system of the **dwelling unit** shall be capable of controlling the heating and cooling system on a daily schedule to maintain different temperature set points at different times of the day **and different days of the week**. This thermostat shall include the capability to set back or temporarily operate the system to maintain **zone** temperatures of not less than 55°F (13°C) to not greater than 85°F (29°C). The thermostat shall be programmed initially by the manufacturer with a heating temperature setpoint of not greater than 70°F (21°C) and a cooling temperature setpoint of not less than 78°F (26°C).

N1103.1.2 (R403.1.2) Heat pump supplementary heat. Heat pumps having supplementary electric-resistance heat shall have controls that, except during defrost, prevent supplemental heat operation when the heat pump compressor can meet the heating load.

N1103.2 (R403.2) Hot water boiler outdoor temperature reset. The manufacturer shall equip each gas, oil and electric boiler (other than a boiler equipped with a tankless domestic water heating coil) with automatic means of adjusting the water temperature supplied by the boiler to ensure incremental change of the inferred heat load will cause

an incremental change in the temperature of the water supplied by the boiler. This can be accomplished with outdoor reset, indoor reset or water temperature sensing.

N1103.3 (R403.3) Ducts. Ducts and air handlers shall be installed in accordance with Sections N1103.3.1 through N1103.3.7.

N1103.3.1 (R403.3.1) Ducts located outside conditioned space. Supply and return ducts located outside *conditioned space* shall be insulated to an *R*-value of not less than R-8 for ducts 3 inches (76 mm) in diameter and larger and not less than R-6 for ducts smaller than 3 inches (76 mm) in diameter. Ducts buried beneath a building shall be insulated as required by this section or have an equivalent thermal distribution efficiency. Underground ducts utilizing the thermal distribution efficiency method shall be listed and labeled to indicate the *R*-value equivalency.

N1103.3.2 (R403.3.2) Ducts located in conditioned space. For ductwork to be considered inside a *conditioned space*, it shall comply with one of the following:

1. The duct system is located completely within the *continuous air barrier* and within the *building thermal envelope*.
2. Ductwork in ventilated attic spaces is buried within ceiling insulation in accordance with Section N1103.3.3 and all of the following conditions exist:
 - 2.1. The air handler is located completely within the *continuous air barrier* and within the *building thermal envelope*.
 - 2.2. The duct leakage, as measured either by a rough-in test of the ducts or a post-construction total system leakage test to outside the *building thermal envelope* in accordance with Section N1103.3.6, is less than or equal to 1.5 cubic feet per minute (42.5 L/min) per 100 square feet (9.29 m²) of *conditioned floor area* served by the duct system.
 - 2.3. The ceiling insulation *R*-value installed against and above the insulated duct is greater than or equal to the proposed ceiling insulation *R*-value, less the *R*-value of the insulation on the duct.
3. Ductwork in floor cavities located over unconditioned space shall have the following:
 - 3.1. A continuous air barrier installed between unconditioned space and the duct.
 - 3.2. Insulation installed in accordance with Section N1102.2.7.
 - 3.3. A minimum R-19 insulation installed in the cavity width separating the duct from unconditioned space.
4. Ductwork located within exterior walls of the building thermal envelope shall have the following:
 - 4.1. A continuous air barrier installed between unconditioned space and the duct.
 - 4.2. Minimum R-10 insulation installed in the cavity width separating the duct from the outside sheathing.
 - 4.3. The remainder of the cavity insulation fully insulated to the drywall side.

N1103.3.3 (R403.3.3) Ducts buried within ceiling insulation. Where supply and return air ducts are partially or completely buried in ceiling insulation, such ducts shall comply with all of the following:

1. The supply and return duct shall have an insulation *R*-value not less than R-8.
2. In Zones 4 and 5, at-A+ all points along each duct, the sum of the ceiling insulation *R*-values against and above the top of the duct, and against and below the bottom of the duct shall be not less than R-19, excluding the *R*-value of the duct insulation.
3. In Climate Zones 0A, 1A, 2A and 3A, Zone 3, the supply ducts shall be completely buried within ceiling insulation, insulated to an *R*-value of not less than R-13 and in compliance with the vapor retarder requirements of Section M1601.4.6.

Exception: Sections of the supply duct that are less than 3 feet (914 mm) from the supply outlet shall not be required to comply with these requirements.

N1103.3.3.1 (R403.3.3.1) Effective *R*-value of deeply buried ducts. Where using the Total Building Performance Compliance Option in accordance with Section N1101.13.2, sections of ducts that are installed in accordance with Section N1103.3.3, located directly on or within 5.5 inches (140 mm) of the ceiling, surrounded with blown-in attic insulation having an *R*-value of R-30 or greater and located such that the top of the duct is

not less than 3.5 inches (89 mm) below the top of the insulation, shall be considered as having an effective duct insulation *R*-value of R-25.

N1103.3.4 (R403.3.4) Sealing. Ducts, air handlers and filter boxes shall be sealed. Joints and seams shall comply with Section M1601.4.1.

N1103.3.4.1 (R403.3.4.1) Sealed air handler. Air handlers shall have a manufacturer's designation for an air leakage of not greater than 2 percent of the design airflow rate when tested in accordance with ASHRAE 193.

N1103.3.5 (R403.3.5) Duct testing. Ducts shall be pressure tested in accordance with ANSI/RESNET/ICC 380 or ASTM E1554 to determine air leakage by one of the following methods:

1. Rough-in test: Total leakage shall be measured with a pressure differential of 0.1 inch w.g. (25 Pa) across the system, including the manufacturer's air handler enclosure if installed at the time of the test. Registers shall be taped or otherwise sealed during the test.
2. Postconstruction test: Total leakage shall be measured with a pressure differential of 0.1 inch w.g. (25 Pa) across the entire system, including the manufacturer's air handler enclosure. Registers shall be taped or otherwise sealed during the test.

Exception: A duct air-leakage test shall not be required for ducts serving heating, cooling or ventilation systems that are not integrated with ducts serving heating or cooling systems.

N1103.3.6 (R403.3.6) Duct leakage. The total leakage of the ducts, where measured in accordance with Section N1103.3.5, shall be as follows:

Duct testing shall be performed and reported by a certified BPI Envelope Professional, a certified HERS rater, or other certified third-party professional trained in duct leakage testing by the test equipment manufacturer.

1. Rough-in test: The total leakage shall be less than or equal to 4.0 cubic feet per minute (113.3 L/min) per 100 square feet (9.29 m²) of **conditioned floor area** where the air handler is installed at the time of the test. Where the air handler is not installed at the time of the test, the total leakage shall be less than or equal to 3.0 cubic feet per minute (85 L/min) per 100 square feet (9.29 m²) of **conditioned floor area**.
2. Postconstruction test: Total leakage shall be less than or equal to 4.0 cubic feet per minute (113.3 L/min) per 100 square feet (9.29 m²) of conditioned floor area.
3. Test for ducts within thermal envelope: Where all ducts and air handlers are located entirely within the building thermal envelope, total leakage shall be less than or equal to 8.0 cubic feet per minute (226.6 L/min) per 100 square feet (9.29 m²) of conditioned floor area.

N1103.3.7 (R403.3.7) Building cavities. *Building* framing cavities shall not be used as ducts or plenums.

N1103.4 (R403.4) Mechanical system piping insulation. Mechanical system piping capable of carrying fluids greater than 105°F (41°C) or less than 55°F (13°C) shall be insulated to an *R*-value of not less than R-3.

N1103.4.1 (R403.4.1) Protection of piping insulation. Piping insulation exposed to weather shall be protected from damage, including that caused by sunlight, moisture, equipment maintenance and wind. The protection shall provide shielding from solar radiation that can cause degradation of the material. Adhesive tape shall be prohibited.

N1103.5 (R403.5) Service hot water systems. Energy conservation measures for service hot water systems shall be in accordance with Sections N1103.5.1 through N1103.5.3.

N1103.5.1 Heated water circulation and temperature maintenance systems. Heated water circulation systems shall be in accordance with Section N1103.5.1.1. Heat trace temperature maintenance systems shall be in accordance with Section N1103.5.1.2. Automatic controls, temperature sensors and pumps shall be in a location with access. Manual controls shall be in a location with ready access.

N1103.5.1.1 (R403.5.1.1) Circulation systems. Heated water circulation systems shall be provided with a circulation pump. The system return pipe shall be a dedicated return pipe or a cold water supply pipe. Gravity and thermosyphon circulation systems shall be prohibited. Controls for circulating hot water system pumps shall automatically turn off the pump when the water in the circulation loop is at the desired temperature and when there is no demand for hot water. The controls shall limit the temperature of the water entering the cold water piping to not greater than 104°F (40°C).

N1103.5.1.1.1 (R403.5.1.1.1) Demand recirculation water systems. Where installed, *demand recirculation water systems* shall have controls that start the pump upon receiving a signal from the action of a user of a fixture or appliance, sensing the presence of a user of a fixture or sensing the flow of hot or tempered water to a fixture fitting or appliance.

N1103.5.1.2 Heat trace systems. Electric heat trace systems shall comply with IEEE 515.1 or UL 515. Controls for such systems shall automatically adjust the energy input to the heat tracing to maintain the desired water temperature in the piping in accordance with the times when heated water is used in the occupancy.

N1103.5.2 (R403.5.2) Hot water pipe insulation. Insulation for *service* hot water piping with a thermal resistance, *R*-value, of not less than R-3 shall be applied to the following:

1. Piping ³/₄ inch (19 mm) and larger in nominal diameter located *inside the conditioned space*.
2. Piping serving more than one *dwelling unit*.
3. Piping located outside the *conditioned space*.
4. Piping from the water heater to a distribution manifold.
5. Piping located under a floor slab.
6. Buried piping.
7. Supply and return piping in *circulation and* recirculation systems other than *cold water pipe return* demand recirculation systems.

N1103.5.3 (R403.5.3) Drain water heat recovery units. Where installed, drain water heat recovery units shall comply with CSA B55.2. Drain water heat recovery units shall be tested in accordance with CSA B55.1. Potable water-side pressure loss of drain water heat recovery units shall be less than 3 psi (20.7 kPa) for individual units connected to one or two showers. Potable water-side pressure loss of drain water heat recovery units shall be less than 2 psi (13.8 kPa) for individual units connected to three or more showers.

N1103.6 (R403.6) Mechanical ventilation. As applicable, *Buildings buildings and dwelling units* shall be provided with *mechanical ventilation* that complies with the requirements of Section M1505 or with other *approved* means of *ventilation*. Outdoor air intakes and exhausts shall have automatic or gravity dampers that close when the *ventilation* system is not operating.

N1103.6.1 (R403.6.1) Heat or energy recovery ventilation. ~~Dwelling units shall be provided with a heat recovery or energy recovery ventilation system in Climate Zones 7 and 8. The system shall be balanced with a minimum sensible heat recovery efficiency of 65 percent at 32°F (0°C) at a flow greater than or equal to the design airflow.~~

N1103.6.2 (R403.6.2) Whole-dwelling mechanical ventilation system fan efficacy. Fans used to provide whole-dwelling mechanical ventilation shall meet the efficacy requirements of Table N1103.6.2 at one or more rating points. Fans shall be tested in accordance with HVI 916 and listed. The airflow shall be reported in the product listing or on the label. Fan efficacy shall be reported in the product listing or shall be derived from the input power and airflow values reported in the product listing or on the label. Fan efficacy for fully ducted HRV, ERC, balanced and in-line fans shall be determined at a static pressure of not less than 0.2 inch water column (49.82 Pa). Fan efficacy for ducted range hoods, bathroom, and utility room fans shall be determined at a static pressure of not less than 0.1 inch water column (24.91 Pa). □

TABLE N1103.6.2 (R403.6.2)

WHOLE-DWELLING MECHANICAL VENTILATION SYSTEM FAN EFFICACY^a

FAN LOCATION	AIRFLOW RATE MINIMUM (CFM)	MINIMUM EFFICACY (CFM/WATT)
HRV, ERV	Any	1.2 cfm/watt □
In-line supply or exhaust fan	Any	3.8 cfm/watt
Other exhaust fan	< 90	2.8 cfm/watt

Other exhaust fan	≥ 90	3.5 cfm/watt
Air-handler that is integrated to tested and listed HVAC equipment	Any	1.2 cfm/watt

For SI: 1 cubic foot per minute = 28.3 L/min.

a. Design outdoor airflow rate/watts of fan used.

N1103.6.3 (R403.6.3) Testing. Mechanical ventilation systems shall be tested and verified to provide the minimum ventilation flow rates required by Section N1103.6. Testing shall be performed according to the ventilation equipment manufacturer’s instructions, or by using a flow hood or box, flow grid, or other airflow measuring device at the mechanical ventilation fan’s inlet terminals or grilles, outlet terminals or grilles, or in the connected ventilation ducts. Where required by the code official, testing shall be conducted by an approved third party. A written report of the results of the test shall be signed by the party conducting the test and provided to the code official.

Exception: Kitchen range hoods that are ducted to the outside with 6-inch (152 mm) or larger duct and not more than one 90-degree (1.57 rad) elbow or equivalent in the duct run.

N1103.7 (R403.7) Equipment sizing and efficiency rating. Heating and cooling *equipment* shall be sized in accordance with ACCA Manual S based on *building* loads calculated in accordance with ACCA Manual J or other *approved* heating and cooling calculation methodologies. New or replacement heating and cooling *equipment* shall have an efficiency rating equal to or greater than the minimum required by federal law for the geographic location where the *equipment* is installed.

N1103.8 (R403.8) Systems serving multiple dwelling units. Systems serving multiple *dwelling units* shall comply with Sections C403 and C404 of the *International Energy Conservation Code*—Commercial Provisions instead of Section N1103.

N1103.9 (R403.9) Snow melt system controls. Snow- and ice-melting systems, supplied through energy service to the building, shall include automatic controls capable of shutting off the system when the pavement temperature is greater than 50°F (10°C) and precipitation is not falling, and an automatic or manual control that will allow shutoff when the outdoor temperature is greater than 40°F (4.8°C).

N1103.10 (R403.10) Energy consumption of pools and spas. The energy consumption of pools and permanent spas shall be controlled by the requirements in Sections N1103.10.1 through N1103.10.3.

N1103.10.1 (R403.10.1) Heaters. The electric power to heaters shall be controlled by an on-off switch that is an integral part of the heater mounted on the exterior of the heater in a location with *ready access*, or external to and within 3 feet (914 mm) of the heater. Operation of such switch shall not change the setting of the heater thermostat. Such switches shall be in addition to a circuit breaker for the power to the heater. Gas-fired heaters shall not be equipped with continuously burning ignition pilots.

N1103.10.2 (R403.10.2) Time switches. Time switches or other control methods that can automatically turn *heaters and pump motors* off and on according to a preset schedule shall be installed for heaters and pump motors. Heaters and pump motors that have built-in time switches shall be in compliance with this section.

Exceptions:

1. Where public health standards require 24-hour pump operation.
2. Pumps that operate solar- and waste-heat-recovery pool heating systems.

N1103.10.3 (R403.10.3) Covers. Outdoor heated pools and outdoor permanent spas shall be provided with a vapor-retardant cover or other *approved* vapor-retardant means.

Exception: Where more than 75 percent of the energy for heating, computed over an operation season of not fewer than 3 calendar months, is from a heat pump or an on-site renewable energy system, covers or other vapor-retardant means shall not be required.

N1103.11 (R403.11) Portable spas. The energy consumption of electric-powered portable spas shall be controlled by the requirements of APSP 14.

N1103.12 (R403.12) Residential pools and permanent residential spas. Where installed, the energy consumption of residential swimming pools and permanent residential spas shall be controlled in accordance with the requirements of APSP 15.

SECTION N1104 (R404) **ELECTRICAL POWER AND LIGHTING SYSTEMS**

N1104.1 (R404.1) Lighting equipment. All permanently installed lighting fixtures, excluding kitchen appliance lighting fixtures, shall contain only *high-efficacy high-effieaeey* lighting sources.

N1104.1.1 (R404.1.1) Exterior lighting. Connected exterior lighting for Group R-2, R-3 and R-4 buildings shall comply with Section C405.4 of the *International Energy Conservation Code*—Commercial Provisions.

Exceptions:

1. Detached one- and two-family dwellings.
2. Townhouses.
3. Solar-powered lamps not connected to any electrical service.
4. Luminaires controlled by a motion sensor.

N1104.1.2 (R404.1.1) Fuel gas lighting equipment. Fuel gas lighting systems shall not have continuously burning pilot lights.

N1104.2 (R404.2) Interior lighting controls. Permanently installed lighting fixtures shall be controlled with a dimmer, an occupant sensor control or another control that is installed or built into the fixture.

Exception: Lighting controls shall not be required for the following:

1. Bathrooms.
2. Hallways.
3. Exterior lighting fixtures.
4. Lighting designed for safety or security.

N1104.3 (R404.3) Exterior lighting controls. Where the total permanently installed exterior lighting power is greater than 30 watts, the permanently installed exterior lighting shall comply with the following:

1. Lighting shall be controlled by a manual on and off switch that permits automatic shut-off actions.

Exception: Lighting serving multiple *dwelling units*.

2. Lighting shall be automatically shut off when daylight is present and satisfies the lighting needs.
3. Controls that override automatic shut-off actions shall not be allowed unless the override automatically returns automatic control to its normal operation within 24 hours.

SECTION N1105 (R405) **TOTAL BUILDING PERFORMANCE**

N1105.1 (R405.1) Scope. This section establishes criteria for compliance using total building performance analysis. Such analysis shall include heating, cooling, mechanical ventilation and service water-heating energy only.

N1105.2 (R405.2) Performance-based compliance. Compliance based on total building performance requires that a *proposed design* meets all of the following:

1. The requirements of the sections indicated within Table N1105.2.
2. The building thermal envelope greater than or equal to levels of efficiency and solar heat gain coefficients in Table R402.1.1 or R402.1.3 of the 2009 International Energy Conservation Code.
3. An annual energy cost that is less than or equal to the annual energy cost of the standard reference design. Energy prices shall be taken from a source approved by the code official, such as the Department of Energy, Energy Information Administration's State Energy Data System Prices and Expenditures reports. Code officials shall be permitted to require time-of-use pricing in energy cost calculations.

Exception: The energy use based on source energy expressed in Btu or Btu per square foot of conditioned floor area shall be permitted to be substituted for the energy cost. The source energy multiplier for electricity shall be 3.16. The source energy multiplier for fuels other than electricity shall be 1.1. □

TABLE N1105.2 (R405.2)
REQUIREMENTS FOR TOTAL BUILDING PERFORMANCE

SECTION ^a	TITLE
General	
N1101.13.5	Additional energy efficiency
N1101.14	Certificate
Building Thermal Envelope	
N1102.1.1	Vapor retarder
N1102.2.3	Eave baffle
N1102.2.4.1	Access hatches and doors
N1102.2.10.1	Crawl space wall insulation installation
N1102.4.1.1	Installation
N1102.4.1.2	Testing
N1102.5	Maximum fenestration U-factor and SHGC
Mechanical	
N1103.1	Controls
N1103.3, including N1103.3.1, except Sections N1103.3.2, N1103.3.3 and N1103.3.6	Ducts
N1103.4	Mechanical system piping insulation
N1103.5.1	Heated water circulation and temperature maintenance systems
N1103.5.3	Drain water heat recovery units
N1103.6	Mechanical ventilation
N1103.7	Equipment sizing and efficiency rating
N1103.8	Systems serving multiple dwelling units
N1103.9	Snow melt system controls
N1103.10	Energy consumption of pools and spas
N1103.11	Portable spas
N1103.12	Residential pools and permanent residential spas
Electrical Power and Lighting Systems	
N1104.1	Lighting equipment
N1104.2	Interior lighting controls

a. Reference to a code section includes all the relative subsections except as indicated in the table.

N1105.3 (R405.3) Documentation. Documentation of the software used for the performance design and the parameters for the *building* shall be in accordance with Sections N1105.3.1 through N1105.3.2.2.

N1105.3.1 (R405.3.1) Compliance software tools. Documentation verifying that the methods and accuracy of the compliance software tools conform to the provisions of this section shall be provided to the *code official*.

N1105.3.2 (R405.3.2) Compliance report. Compliance software tools shall generate a report that documents that the *proposed design* complies with Section N1105.3. A compliance report on the *proposed design* shall be submitted with the application for the building permit. Upon completion of the building, a confirmed compliance report based on the confirmed condition of the building shall be submitted to the *code official* before a certificate of occupancy is issued.

Compliance reports shall include information in accordance with Sections N1105.3.1 and N1105.3.2.2.

N1105.3.2.1 (R405.3.2.1) Compliance report for permit application. A compliance report submitted with the application for building permit shall include the following:

1. Building street address, or other *building site* identification.
2. The name of the individual performing the analysis and generating the compliance report.
3. The name and version of the compliance software tool.
4. Documentation of all inputs entered into the software used to produce the results for the reference design and/or the rated home.
5. A certificate indicating that the proposed design complies with Section N1105.3. The certificate shall document the building components' energy specifications that are included in the calculation, including component-level insulation *R*-values or *U*-factors; duct system and building envelope air leakage testing assumptions; and the type and rated efficiencies of proposed heating, cooling, mechanical ventilation and service water-heating equipment to be installed. If on-site renewable energy systems will be installed, the certificate shall report the type and production size of the proposed system.
6. When a site-specific report is not generated, the proposed design shall be based on the worst-case orientation and configuration of the rated home.

N1105.3.2.2 (R405.3.2.2) Compliance report for certificate of occupancy. A compliance report submitted for obtaining the certificate of occupancy shall include the following:

1. Building street address, or other building site identification.
2. Declaration of the total building performance path on the title page of the energy report and the title page of the building plans.
3. A statement, bearing the name of the individual performing the analysis and generating the report, indicating that the as-built building complies with Section N1105.3.
4. The name and version of the compliance software tool.
5. A site-specific energy analysis report that is in compliance with Section N1105.3.
6. A final confirmed certificate indicating compliance based on inspection, and a statement indicating that the confirmed rated design of the built home complies with Section N1105.3. The certificate shall report the energy features that were confirmed to be in the home, including component-level insulation *R*-values or *U*-factors; results from any required duct system and building envelope air leakage testing; and the type and rated efficiencies of the heating, cooling, mechanical ventilation and service water heating equipment installed.
7. Where on-site renewable energy systems have been installed, the certificate shall report the type and production size of the installed system.

N1105.4 (R405.4) Calculation procedure. Calculations of the performance design shall be in accordance with Sections N1105.4.1 and N1105.4.2.

N1105.4.1 (R405.4.1) General. Except as specified by this section, the *standard reference design* and *proposed design* shall be configured and analyzed using identical methods and techniques.

N1105.4.2 (R405.4.2) Residence specifications. The *standard reference design* and *proposed design* shall be configured and analyzed as specified by Table N1105.4.2(1). Table N1105.4.2(1) shall include, by reference, all notes contained in Table N1102.1.3.

TABLE N1105.4.2(1) [R405.4.2(1)]

SPECIFICATIONS FOR THE STANDARD REFERENCE AND PROPOSED DESIGNS

BUILDING COMPONENT	STANDARD REFERENCE DESIGN	PROPOSED DESIGN
Above-grade walls	Type: mass where the proposed wall is a mass wall; otherwise wood frame.	As proposed
	Gross area: same as proposed.	As proposed
	<i>U</i> -factor: as specified in Table N1102.1.2.	As proposed
	Solar absorptance = 0.75.	As proposed
	Emittance = 0.90.	As proposed
Basement and crawl space walls	Type: same as proposed.	As proposed
	Gross area: same as proposed.	As proposed
	<i>U</i> -factor: as specified in Table N1102.1.2, with the insulation layer on the interior side of the walls.	As proposed
Above-grade floors	Type: wood frame.	As proposed
	Gross area: same as proposed.	As proposed
	<i>U</i> -factor: as specified in Table N1102.1.2.	As proposed
Ceilings	Type: wood frame.	As proposed
	Gross area: same as proposed.	As proposed
	<i>U</i> -factor: as specified in Table N1102.1.2.	As proposed
Roofs	Type: composition shingle on wood sheathing.	As proposed
	Gross area: same as proposed.	As proposed
	Solar absorptance = 0.75.	As proposed
	Emittance = 0.90.	As proposed
Attics	Type: vented with an aperture of 1 ft ² per 300 ft ² of ceiling area.	As proposed
Foundations	Type: same as proposed.	As proposed
	Foundation wall area above and below grade and soil characteristics: same as proposed.	As proposed
Opaque doors	Area: 40 ft ² .	As proposed
	Orientation: North.	As proposed
	<i>U</i> -factor: same as fenestration as specified in Table N1102.1.2.	As proposed
Vertical fenestration other than opaque doors	Total area ^b = (a) The proposed glazing area, where the proposed glazing area is less than 45 12 percent of the conditioned floor building thermal envelope above-grade wall area. (b) 45 12 percent of the conditioned floor area, where the proposed glazing area is 45 12 percent or more of the conditioned floor building thermal envelope above-grade wall area.	As proposed
	Orientation: equally distributed to four cardinal compass orientations (N, E, S & W).	As proposed

	<i>U</i> -factor: as specified in Table N1102.1.2.	As proposed
	SHGC: as specified in Table N1102.1.2 except for climate zones without an SHGC requirement, the SHGC shall be equal to 0.40.	As proposed
	Interior shade fraction: $0.92 - (0.21 \times \text{SHGC for the standard reference design})$.	Interior shade fraction: $0.92 - (0.21 \times \text{SHGC as proposed})$
	External shading: none	As proposed
Skylights	None	As proposed
Thermally isolated sunrooms	None	As proposed

(continued)

TABLE N1105.4.2(1) [R405.4.2(1)]—continued
SPECIFICATIONS FOR THE STANDARD REFERENCE AND PROPOSED DESIGNS

BUILDING COMPONENT	STANDARD REFERENCE DESIGN	PROPOSED DESIGN
Air exchange rate	The air leakage rate at a pressure of 0.2 inch w.g. (50 Pa) shall be Climate Zones 0 through 2: 5.0 air changes per hour. Climate Zones 3 through 4: 3.0 air changes per hour.	The measured air exchange rate. ^a
	The mechanical ventilation rate shall be in addition to the air leakage rate and shall be the same as in the proposed design, but not greater than $0.01 \times CFA + 7.5 \times (N_{br} + 1)$ where: CFA = conditioned floor area, ft ² . N_{br} = number of bedrooms. The mechanical ventilation system type shall be the same as in the proposed design. Energy recovery shall not be assumed for mechanical ventilation.	
Mechanical ventilation	Where mechanical ventilation is not specified in the proposed design: None Where mechanical ventilation is specified in the proposed design, the annual vent fan energy use, in units of kWh/yr, shall equal $(1/e_f) \times [0.0876 \times CFA + 65.7 \times (N_{br} + 1)]$ where: e_f = the minimum exhaust fan efficacy, as specified in Table N1103.6.2, corresponding to the system type at a flow rate of $0.01 \times CFA + 7.5 \times (N_{br} + 1)$ CFA = conditioned floor area, ft ² . N_{br} = number of bedrooms.	As proposed
Internal gains	IGain, in units of Btu/day per dwelling unit, shall equal $17,900 + 23.8 \times CFA + 4,104 \times N_{br}$ where: CFA = conditioned floor area, ft ² . N_{br} = number of bedrooms.	Same as standard reference design.

Internal mass	Internal mass for furniture and contents: 8 pounds per square foot of floor area.	Same as standard reference design, plus any additional mass specifically designed as a thermal storage element ^c but not integral to the building envelope or structure.
Structural mass	For masonry floor slabs: 80 percent of floor area covered by R-2 carpet and pad, and 20 percent of floor directly exposed to room air.	As proposed
	For masonry basement walls: as proposed, but with insulation as specified in Table N1102.1.3, located on the interior side of the walls.	As proposed
	For other walls, ceilings, floors, and interior walls: wood frame construction.	As proposed
Heating systems ^{d, e}	For other than electric heating without a heat pump: as proposed. Where the proposed design utilizes electric heating without a heat pump, the standard reference design shall be an air source heat pump meeting the requirements of Section C403 of the IECC—Commercial Provisions. Capacity: sized in accordance with Section N1103.7.	As proposed
Cooling systems ^{d, f}	As proposed. Capacity: sized in accordance with Section N1103.7.	As proposed

(continued)

TABLE N1105.4.2(1) [R405.4.2(1)]—continued
SPECIFICATIONS FOR THE STANDARD REFERENCE AND PROPOSED DESIGNS

BUILDING COMPONENT	STANDARD REFERENCE DESIGN	PROPOSED DESIGN			
Service water heating ^{d, g}	As proposed. Use, in units of gal/day = $30 + (10 \times N_{br})$ where: N_{br} = number of bedrooms.	As proposed			
		Use, in units of gal/day = $25.5 + (8.5 \times N_{br}) \times (1 - HWDS)$ where: N_{br} = number of bedrooms. $HWDS$ = factor for the compactness of the hot water distribution system.			
		Compactness ratio ^l factor		HWDS	
		1 story	2 or more stories		
		> 60%	> 30%		0
		> 30% to ≤ 60%	> 15% to ≤ 30%		0.05
		> 15% to ≤ 30%	> 7.5% to ≤ 15%		0.10
< 15%	< 7.5%		0.15		

Thermal distribution systems	<p>Duct insulation: in accordance with Section N1103.3.1.</p> <p>A thermal distribution system efficiency (DSE) of 0.88 shall be applied to both the heating and cooling system efficiencies for all systems other than tested duct systems.</p> <p>Duct location: same as proposed design.</p> <p>Exception: For nonducted heating and cooling systems that do not have a fan, the standard reference design thermal distribution system efficiency (DSE) shall be 1. For tested duct systems, the leakage rate shall be 4 cfm (113.3 L/min) per 100 ft² (9.29 m²) of conditioned floor area at a pressure of differential of 0.1 inch w.g. (25 Pa).</p>	<p>Duct insulation: as proposed.</p> <p>As tested or, where not tested, as specified in Table N1105.4.2(2).</p>
Thermostat	Type: Manual, cooling temperature setpoint = 75°F; Heating temperature setpoint = 72°F.	Same as standard reference design.
Dehumidistat	<p>Where a mechanical ventilation system with latent heat recovery is not specified in the proposed design:</p> <p>None.</p> <p>Where the proposed design utilizes a mechanical ventilation system with latent heat recovery:</p> <p>Dehumidistat type: manual, setpoint = 60% relative humidity.</p> <p>Dehumidifier: whole-dwelling with integrated energy factor = 1.77 liters/kWh.</p>	Same as standard reference design.

(continued)

TABLE N1105.4.2(1) [R405.4.2(1)]—continued
SPECIFICATIONS FOR THE STANDARD REFERENCE AND PROPOSED DESIGNS

For SI: 1 square foot = 0.93 m², 1 British thermal unit = 1055 J, 1 pound per square foot = 4.88 kg/m², 1 gallon (US) = 3.785 L, °C = (°F – 32)/1.8,

1 degree = 0.79 rad.

- a. Where required by the code official, testing shall be conducted by an approved party. Hourly calculations as specified in the ASHRAE *Handbook of Fundamentals*, or the equivalent, shall be used to determine the energy loads resulting from infiltration.
- b. The combined air exchange rate for infiltration and mechanical ventilation shall be determined in accordance with Equation 43 of 2001 ASHRAE *Handbook of Fundamentals*, page 26.24 and the “Whole-house Ventilation” provisions of 2001 ASHRAE *Handbook of Fundamentals*, page 26.19 for intermittent mechanical ventilation.
- c. Thermal storage element shall mean a component that is not part of the floors, walls or ceilings that is part of a passive solar system, and that provides thermal storage such as enclosed water columns, rock beds, or phase-change containers. A thermal storage element shall be in the same room as fenestration that faces within 15 degrees (0.26 rad) of true south, or shall be connected to such a room with pipes or ducts that allow the element to be actively charged.
- d. For a proposed design with multiple heating, cooling or water heating systems using different fuel types, the applicable standard reference design system capacities and fuel types shall be weighted in accordance with their respective loads as calculated by accepted engineering practice for each equipment and fuel type present.
- e. For a proposed design without a proposed heating system, a heating system having the prevailing federal minimum efficiency shall be assumed for both the standard reference design and proposed design.
- f. For a proposed design home without a proposed cooling system, an electric air conditioner having the prevailing federal minimum efficiency shall be assumed for both the standard reference design and the proposed design.
- g. For a proposed design with a nonstorage-type water heater, a 40-gallon storage-type water heater having the prevailing federal minimum energy factor for the same fuel as the predominant heating fuel type shall be assumed. For a proposed design without a proposed water heater, a 40-gallon storage-type water heater having the prevailing federal minimum efficiency for the same fuel as the predominant heating fuel type shall be assumed for both the proposed design and standard reference design.
- h. For residences with conditioned basements, R-2 and R-4 residences, and for townhouses, the following formula shall be used to determine glazing area:

$$AF = A_s \times FA \times F$$

where:

AF = Total glazing area.

A_s = Standard reference design total glazing area.

FA = (Above-grade thermal boundary gross wall area)/(above-grade boundary wall area + 0.5 × below-grade boundary wall area);

F = (above-grade thermal boundary wall area)/(above-grade thermal boundary wall area + common wall area) or 0.56, whichever is greater.

and where:

Thermal boundary wall is any wall that separates conditioned space from unconditioned space or ambient conditions.

Above-grade thermal boundary wall is any thermal boundary wall component not in contact with soil.

Below-grade boundary wall is any thermal boundary wall in soil contact.

Common wall area is the area of walls shared with an adjoining dwelling unit.

h. not used

- i. The factor for the compactness of the hot water distribution system is the ratio of the area of the rectangle that bounds the source of hot water and the fixtures that it serves (the “hot water rectangle”) divided by the floor area of the dwelling.
 1. Sources of hot water include water heaters, or in multiple-family buildings with central water heating systems, circulation loops or electric heat traced pipes.
 2. The hot water rectangle shall include the source of hot water and the points of termination of all hot water fixture supply piping.
 3. The hot water rectangle shall be shown on the floor plans and the area shall be computed to the nearest square foot.
 4. Where there is more than one water heater and each water heater serves different plumbing fixtures and appliances, it is permissible to establish a separate hot water rectangle for each hot water distribution system and add the area of these rectangles together to determine the compactness ratio.
 5. The basement or attic shall be counted as a story when it contains the water heater.
 6. Compliance shall be demonstrated by providing a drawing on the plans that shows the hot water distribution system rectangle(s), comparing the area of the rectangle(s) to the area of the dwelling and identifying the appropriate compactness ratio and HWDS factor.

TABLE N1105.4.2(2) [R405.4.2(2)]

DEFAULT DISTRIBUTION SYSTEM EFFICIENCIES FOR PROPOSED DESIGNS^a

DISTRIBUTION SYSTEM CONFIGURATION AND CONDITION	FORCED AIR SYSTEMS	HYDRONIC SYSTEMS ^b
Distribution system components located in unconditioned space	—	0.95
Untested distribution systems entirely located in conditioned space ^c	0.88	1
“Ductless” systems ^d	1	—

- a. Default values this table are for untested distribution systems, which must still meet minimum requirements for duct system insulation.
- b. Hydronic systems shall mean those systems that distribute heating and cooling energy directly to individual spaces using liquids pumped through closed-loop piping and that do not depend on ducted, forced airflow to maintain space temperatures.
- c. Entire system in conditioned space shall mean that no component of the distribution system, including the air handler unit, is located outside of the conditioned space.
- d. Ductless systems shall be allowed to have forced airflow across a coil but shall not have any ducted airflow external to the manufacturer’s air handler enclosure.

N1105.5 (R405.5) Calculation software tools. Calculation software, where used, shall be in accordance with Sections N1105.5.1 through N1105.5.3.

N1105.5.1 (R405.5.1) Minimum capabilities. Calculation procedures used to comply with this section shall be software tools capable of calculating the annual energy consumption of all building elements that differ between the *standard reference design* and the *proposed design* and shall include the following capabilities:

1. Computer generation of the *standard reference design* using only the input for the *proposed design*. The calculation procedure shall not allow the user to directly modify the building component characteristics of the *standard reference design*.
2. Calculation of whole-building (as a single *zone*) sizing for the heating and cooling *equipment* in the *standard reference design* residence in accordance with Section N1103.6.
3. Calculations that account for the effects of indoor and outdoor temperatures and part-load ratios on the performance of heating, ventilating and air-conditioning *equipment* based on climate and *equipment* sizing.
4. Printed *code official* inspection checklist listing each of the *proposed design* component characteristics from Table N1105.4.2(1) determined by the analysis to provide compliance, along with their respective performance ratings such as *R*-value, *U*-factor, SHGC, HSPF, AFUE, SEER and EF.

N1105.5.2 (R405.5.2) Specific approval. Performance analysis tools meeting the applicable provisions of Section N1105 shall be permitted to be *approved*. Tools are permitted to be *approved* based on meeting a specified

threshold for a *jurisdiction*. The *code official* shall be permitted to approve such tools for a specified application or limited scope.

N1105.5.3 (R405.5.3) Input values. When calculations require input values not specified by Sections N1102, N1103, N1104 and N1105, those input values shall be taken from an *approved* source.

**SECTION N1106 (R406)
ENERGY RATING INDEX
COMPLIANCE ALTERNATIVE**

N1106.1 (R406.1) Scope. This section establishes criteria for compliance using an Energy Rating Index (ERI) analysis. □

N1106.2 (R406.2) ERI compliance. Compliance based on the Energy Rating Index (ERI) requires that the rated design meet all of the following:

1. The requirements of the sections indicated within Table N1106.2.
2. Maximum ERI of Table N1106.5.

**TABLE N1106.2 (R406.2)
REQUIREMENTS FOR ENERGY RATING INDEX**

SECTION*	TITLE
General	
N1101.13.5	Additional efficiency packages
N1101.14	Certificate
Building Thermal Envelope	
N1102.1.1	Vapor retarder
N1102.2.3	Eave baffle
N1102.2.4.1	Access hatches and doors
N1102.2.10.1	Crawl space wall insulation installation
N1102.4.1.1	Installation
N1102.4.1.2	Testing
Mechanical	
N1103.1	Controls
N1103.3 except Sections N1103.3.2, N1103.3.3 and N1103.3.6	Ducts
N1103.4	Mechanical system piping insulation
N1103.5.1	Heated water circulation and temperature maintenance systems
N1103.5.3	Drain water heat recovery units
N1103.6	Mechanical ventilation
N1103.7	Equipment sizing and efficiency rating
N1103.8	Systems serving multiple dwelling units
N1103.9	Snow melt system controls
N1103.10	Energy consumption of pools and spas

N1103.11	Portable spas
N1103.12	Residential pools and permanent residential spas
Electrical Power and Lighting Systems	
N1104.1	Lighting equipment
N1104.2	Interior lighting controls
N1106.3	Building thermal envelope

- a. Reference to a code section includes all of the relative subsections except as indicated in the table.

N1106.3 (R406.3) Building thermal envelope. Building and portions thereof shall comply with Section N1106.3.1 or N1106.3.2.

N1106.3.1 (R406.3.1) On-site renewables are not included. Where on-site renewable energy is not included for compliance using the ERI analysis of Section N1106.4, the proposed total building thermal envelope UA, which is sum of U-factor times assembly area, shall be less than or equal to the building thermal envelope UA using the prescriptive U-factors from Table N1102.1.2 multiplied by 1.15 in accordance with Equation 11-4. The area-weighted maximum fenestration SHGC permitted in Climate Zones 0 through 3 shall be 0.30.

$$UA_{\text{Proposed design}} = 1.15 \times UA_{\text{Prescriptive reference design}}$$

(Equation 11-4)

N1106.3.2 (R406.3.2) On-site renewables are included. Where on-site renewable energy is included for compliance using the ERI analysis of Section N1106.4, the building thermal envelope shall be greater than or equal to the levels of efficiency and SHGC in Table N1102.1.2, or Table R402.1.4 of the 2015 *International Energy Conservation Code*.

N1106.4 (R406.4) Energy Rating Index. The Energy Rating Index (ERI) shall be determined in accordance with RESNET/ICC 301 except that the *ERI reference design* ventilation rate shall be in accordance with Equation 11-5.

$$\text{Ventilation rate, CFM} = (0.01 \times \text{total square foot area of house}) + [7.5 \times (\text{number of bedrooms} + 1)]$$

(Equation 11-5)

Energy used to recharge or refuel a vehicle used for transportation on roads that are not on the *building site* shall not be included in the *ERI reference design* or the *rated design*. For compliance purposes, any reduction in energy use of the rated design associated with on-site renewable energy shall not exceed 5 percent of the total energy use.

N1106.5 (R406.5) ERI-based compliance. Compliance based on an ERI analysis requires that the *rated proposed design* and *confirmed built dwelling* be shown to have an ERI less than or equal to the appropriate value indicated in Table N1106.5 when compared to the *ERI reference design*.

TABLE N1106.5 (R406.5)

MAXIMUM ENERGY RATING INDEX

CLIMATE ZONE	ENERGY RATING INDEX
0-1	52
2	52
3	51
4	54
5	55
6	54
7	53
8	53 □

N1106.6 (R406.6) Verification by approved agency. Verification of compliance with Section N1106 as outlined in Sections N1106.4 and N1106.6 shall be completed by an *approved* third party. Verification of compliance with Section N1106.2 shall be completed by the authority having jurisdiction or an approved third-party inspection agency in accordance with Section R105.4.

N1106.7 (R406.7) Documentation. Documentation of the software used to determine the ERI and the parameters for the *residential building* shall be in accordance with Sections N1106.7.1 through N1106.7.4.

N1106.7.1 (R406.7.1) Compliance software tools. Software tools used for determining ERI shall be *Approved* Software Rating Tools in accordance with RESNET/ICC 301.

N1106.7.2 (R406.7.2) Compliance report. Compliance software tools shall generate a report that documents that the home and the ERI score of the *rated design* comply with Sections N1106.2, N1106.3 and N1106.4. Compliance

documentation shall be created for the proposed design and shall be submitted with the application for the building permit. Confirmed compliance documents of the built dwelling unit shall be created and submitted to the code official for review before a certificate of occupancy is issued. Compliance reports shall include information in accordance with Sections N1106.7.2.1 and N1106.7.2.2. □

N1106.7.2.1 (R406.7.2.1) Proposed compliance report for permit application. Compliance reports submitted with the application for a building permit shall include the following:

1. Building street address, or other *building site* identification.
2. Declaration of ERI on the title page and on the building plans.
3. The name of the individual performing the analysis and generating the compliance report.
4. The name and version of the compliance software tool.
5. Documentation of all inputs entered into the software used to produce the results for the reference design and/or the rated home.
6. A certificate indicating that the proposed design has an ERI less than or equal to the appropriate score indicated in Table N1106.5 when compared to the ERI reference design. The certificate shall document the building component energy specifications that are included in the calculation, including: component level insulation *R*-values or *U*-factors; assumed duct system and building envelope air leakage testing results; and the type and rated efficiencies of proposed heating, cooling, mechanical ventilation and service water-heating equipment to be installed. If on-site renewable energy systems will be installed, the certificate shall report the type and production size of the proposed system.
7. When a site-specific report is not generated, the proposed design shall be based on the worst-case orientation and configuration of the rated home.

N1106.7.2.2 (R406.7.2.2) Confirmed compliance report for a certificate of occupancy. A confirmed compliance report submitted for obtaining the certificate of occupancy shall be made site and address specific and include the following:

1. Building street address or other *building site* identification.
2. Declaration of ERI on the title page and on the building plans.
3. The name of the individual performing the analysis and generating the report.
4. The name and version of the compliance software tool.
5. Documentation of all inputs entered into the software used to produce the results for the reference design and/or the rated home.
6. A final confirmed certificate indicating that the confirmed rated design of the built home complies with Sections N1106.2 and N1106.4. The certificate shall report the energy features that were confirmed to be in the home, including: component-level insulation *R*-values or *U*-factors; results from any required duct system and building envelope air leakage testing; and the type and rated efficiencies of the heating, cooling, mechanical ventilation, and service water-heating equipment installed. Where on-site renewable energy systems have been installed on or in the home, the certificate shall report the type and production size of the installed system.

N1106.7.3 (R406.7.3) Renewable energy certificate (REC) documentation. Where on-site renewable energy is included in the calculation of an ERI, one of the following forms of documentation shall be provided to the code official:

1. **Substantiation that the RECs associated with the on-site renewable energy are owned by, or retired on behalf of, the homeowner.**
2. A contract that conveys to the homeowner the RECs associated with the on-site renewable energy, or conveys to the homeowner an equivalent quantity of RECs associated with other renewable energy.

N1106.7.4 (R406.7.4) Additional documentation. The *code official* shall be permitted to require the following documents:

1. Documentation of the building component characteristics of the *ERI reference design*.
2. A certification signed by the builder providing the building component characteristics of the *rated design*.
3. Documentation of the actual values used in the software calculations for the *rated design*.

N1106.7.5 (R406.7.5) Specific approval. Performance analysis tools meeting the applicable subsections of Section N1106 shall be **approved**. Documentation demonstrating the approval of performance analysis tools in accordance with Section N1106.7.1 shall be provided.

N1106.7.6 (R406.7.6) Input values. Where calculations require input values not specified by Sections N1102, N1103, N1104 and N1105, those input values shall be taken from RESNET/ICC 301.

SECTION N1107 (R407) TROPICAL CLIMATE REGION COMPLIANCE PATH

N1107.1 (R407.1) Scope. ~~Deleted. This section establishes alternative criteria for residential buildings in the tropical region at elevations less than 2,400 feet (731.5 m) above sea level.~~ **

N1107.2 (R407.2) Tropical climate region. Compliance with this section requires the following:

- ~~1. Not more than one-half of the occupied space is air conditioned.~~
- ~~2. The occupied space is not heated.~~
- ~~3. Solar, wind or other renewable energy source supplies not less than 80 percent of the energy for service water heating.~~
- ~~4. Glazing in conditioned spaces has a solar heat gain coefficient (SHGC) of less than or equal to 0.40, or has an overhang with a projection factor equal to or greater than 0.30.~~
- ~~5. Permanently installed lighting is in accordance with Section N1104.~~
- ~~6. The exterior roof surface complies with one of the options in Table C402.3 of the International Energy Conservation Code or the roof or ceiling has insulation with an R value of R-15 or greater. Where attics are present, attics above the insulation are vented and attics below the insulation are unvented.~~
- ~~7. Roof surfaces have a slope of not less than $\frac{1}{4}$ unit vertical in 12 units horizontal (21 percent slope). The finished roof does not have water accumulation areas.~~
- ~~8. Operable fenestration provides a ventilation area of not less than 14 percent of the floor area in each room. Alternatively, equivalent ventilation is provided by a ventilation fan.~~
- ~~9. Bedrooms with exterior walls facing two different directions have operable fenestration on exterior walls facing two directions.~~
- ~~10. Interior doors to bedrooms are capable of being secured in the open position.~~
- ~~11. A ceiling fan or ceiling fan rough in is provided for bedrooms and the largest space that is not used as a bedroom.~~ □

SECTION N1108 (R408) ADDITIONAL EFFICIENCY PACKAGE OPTIONS

N1108.1 (R408.1) Scope. This section establishes additional efficiency package options to achieve additional energy efficiency in accordance with Section N1101.13.5.

N1108.2 (R408.2) Additional efficiency package options. Additional efficiency package options for compliance with Section N1101.13.5 are set forth in Sections N1108.2.1 through N1108.2.5.

N1108.2.1 (R408.2.1) Enhanced envelope performance option. The total building thermal envelope UA, the sum of U-factor times assembly area, shall be less than or equal to 95 percent of the total UA resulting from multiplying the U-factors in Table N1102.1.2 by the same assembly area as in the proposed building. The UA calculation shall be performed in accordance with Section N1102.1.5. The area-weighted average SHGC of all glazed fenestration shall be less than or equal to 95 percent of the maximum glazed fenestration SHGC in Table N1102.1.2.

N1108.2.2 (R408.2.2) More efficient HVAC equipment performance option. Heating and cooling equipment shall meet one of the following efficiencies:

1. Greater than or equal to 95 AFUE natural gas furnace and 16 SEER air conditioner.
2. Greater than or equal to 10 HSPF/16 SEER air source heat pump.

3. Greater than or equal to 3.5 COP ground source heat pump. For multiple cooling systems, all systems shall meet or exceed the minimum efficiency requirements in this section and shall be sized to serve 100 percent of the cooling design load. For multiple heating systems, all systems shall meet or exceed the minimum efficiency requirements in this section and shall be sized to serve 100 percent of the heating design load.

N1108.2.3 (R408.2.3) Reduced energy use in service water-heating option. The hot water system shall meet one of the following efficiencies:

1. Greater than or equal to 82 EF fossil fuel service water-heating system.
2. Greater than or equal to 2.0 EF electric service water-heating system.
3. Greater than or equal to 0.4 solar fraction solar water-heating system.

N1108.2.4 (R408.2.4) More efficient duct thermal distribution system option. The thermal distribution system shall meet one of the following efficiencies:

1. 100 percent of ducts and air handlers located entirely within the building thermal envelope.
2. 100 percent of ductless thermal distribution system or hydronic thermal distribution system located completely inside the building thermal envelope.
3. 100 percent of duct thermal distribution system located in conditioned space as defined by Section N1103.3.2.

N1108.2.5 (R408.2.5) Improved air sealing and efficient ventilation system option. The measured air leakage rate shall be less than or equal to 3.0 ACH50, with either an Energy Recovery Ventilator (ERV) or Heat Recovery Ventilator (HRV) installed. Minimum HRV and ERV requirements, measured at the lowest tested net supply airflow, shall be greater than or equal to 75 percent Sensible Recovery Efficiency (SRE), less than or equal to 1.1 cubic feet per minute per watt (0.03 m³/min/watt) and shall not use recirculation as a defrost strategy. In addition, the ERV shall be greater than or equal to 50 percent Latent Recovery/Moisture Transfer (LRMT).

SECTION N1109 (R501) EXISTING BUILDINGS—GENERAL

N1109.1 (R501.1) Scope. The provisions of Sections N1109 through N1113 shall control the *alteration, repair, addition* and *change of occupancy* of existing *buildings* and structures.

N1109.1.1 (R501.1.1) General. Except as specified in this chapter, this code shall not be used to require the removal, *alteration* or abandonment of, nor prevent the continued use and maintenance of, an existing *building* or *building* system lawfully in existence at the time of adoption of this code. *Unaltered portions of the existing building, or building supply system shall not be required to comply with this code.*

N1109.2 (R501.2) Compliance. *Additions, alterations, repairs* or changes of occupancy to, or relocation of, an existing *building, building* system or portion thereof shall comply with Section N1110, N1111, N1112 or N1113, respectively, in this code. Changes where unconditioned space is changed to *conditioned space* shall comply with Section N1110.

N1109.3 (R501.3) Maintenance. *Buildings* and structures, and parts thereof, shall be maintained in a safe and sanitary condition. Devices and systems that are required by this code shall be maintained in compliance with the code edition under which installed. The *owner* or the owner's authorized agent shall be responsible for the maintenance of *buildings* and structures. The requirements of this chapter shall not provide the basis for removal or abrogation of energy conservation, fire protection and safety systems and devices in existing structures.

N1109.4 (R501.4) Compliance. *Alterations, repairs, additions* and changes of occupancy to, or relocation of, existing *buildings* and structures shall comply with the provisions for *alterations, repairs, additions* and changes of occupancy or relocation, respectively, in this code.

N1109.5 (R501.5) New and replacement materials. Except as otherwise required or permitted by this code, materials permitted by the applicable code for new construction shall be used. Like materials shall be permitted for *repairs*, provided that hazards to life, health or property are not created. Hazardous materials shall not be used where the code for new construction would not allow their use in *buildings* of similar occupancy, purpose and location.

N1109.6 (R501.6) Historic buildings. Provisions of this chapter relating to the construction, *repair, alteration, restoration* and movement of structures, and *change of occupancy* shall not be mandatory for *historic buildings* provided that a report has been submitted to the *building official* and signed by the *owner, a registered design*

professional, or a representative of the State Historic Preservation Office or the historic preservation authority having *jurisdiction*, demonstrating that compliance with that provision would threaten, degrade or destroy the historic form, fabric or function of the *building*.

SECTION N1110 (R502) ADDITIONS

N1110.1 (R502.1) General. *Additions* to an existing *building*, *building* system or portion thereof shall conform to the provisions of this chapter as they relate to new construction without requiring the unaltered portion of the existing *building* or *building* system to comply with this chapter. *Additions* shall not create an unsafe or hazardous condition or overload existing *building* systems. An *addition* shall be deemed to comply with this chapter where the *addition* alone complies, where the existing *building* and *addition* comply with this chapter as a single *building*, or where the *building* with the *addition* does not use more energy than the existing *building*. *Additions* shall be in accordance with Section N1110.1.1 or N1110.1.2.

N1110.2 (R502.2) Change in space conditioning. Any unconditioned or low energy space that is altered to become *conditioned space* shall be required to be brought into full compliance with this chapter.

Exceptions:

1. Where the simulated performance option in Section N1105 is used to comply with this section, the annual energy cost of the proposed design is permitted to be 110 percent of the annual energy cost otherwise allowed by Section N1105.3.
2. Where the Total UA, as determined in Section N1102.1.5, of the existing building and the addition, and any alterations that are part of the project, is less than or equal to the Total UA generated for the existing building.
3. Where complying in accordance with Section N1105 and the annual energy cost or energy use of the addition and the existing building, and any alterations that are part of the project, is less than or equal to the annual energy cost of the existing building. The addition and any alterations that are part of the project shall comply with Section N1105 in its entirety.

N1110.3 (R502.3) Prescriptive compliance. *Additions* shall comply with Sections N1110.3.1 through N1110.3.4.

N1110.3.1 (R502.3.1) Building envelope. New *building* envelope assemblies that are part of the *addition* shall comply with Sections N1102.1, N1102.2, N1102.3.1 through N1102.3.5, and N1102.4.

Exception: New envelope assemblies are exempt from the requirements of Section N1102.4.1.2.

N1110.3.2 (R502.3.2) Heating and cooling systems. HVAC ducts newly installed as part of an *addition* shall comply with Section N1103.

Exception: Where ducts from an existing heating and cooling system are extended to an *addition*.

N1110.3.3 (R502.3.3) Service hot water systems. New service hot water systems that are part of the *addition* shall comply with Section N1103.5.

N1110.3.4 (R502.3.4) Lighting. New lighting systems that are part of the *addition* shall comply with Section N1104.1. □

SECTION N1111 (R503) ALTERATIONS

N1111.1 (R503.1) General. *Alterations* to any *building* or structure shall comply with the requirements of the code for new construction, without requiring the unaltered portions of the existing building or building system to comply with this chapter. *Alterations* shall be such that the existing *building* or structure is not less conforming with the provisions of this chapter than the existing building or structure was prior to the *alteration*.

Alterations shall not create an unsafe or hazardous condition or overload existing *building* systems. *Alterations* shall be such that the existing *building* or structure does not use more energy than the existing *building* or structure prior to the *alteration*. *Alterations* to existing *buildings* shall comply with Sections N1111.1.1 through N1111.1.4.

N1111.1.1 (R503.1.1) Building envelope. *Building* envelope assemblies that are part of the *alteration* shall comply with Section N1102.1.2 or N1102.1.4, Sections N1102.2.1 through N1102.2.12, N1102.3.1, N1102.3.2, N1102.4.3 and N1102.4.5.

Exception: The following *alterations* shall not be required to comply with the requirements for new construction provided that the energy use of the *building* is not increased:

1. Storm windows installed over existing fenestration.
2. Existing ceiling, wall or floor cavities exposed during construction provided that these cavities are filled with insulation. **Minimally this shall require: 2x4 cavity – R-13, 2x6 cavity – R-19, 2x8 cavity – R-30, 2x10 cavity – R-30, 2x12 cavity – R-38. See Section 504 Repairs for more specific language for repairs. Ventilated cladding air spaces shall not be required to be filled.**
3. Construction where the existing roof, wall or floor cavity is not exposed.
4. **Roof recover.**
5. Roofs without insulation in the cavity and where the sheathing or insulation is exposed during *reroofing* shall be insulated either above or below the sheathing.
6. Surface-applied window film installed on existing single-pane fenestration assemblies to reduce solar heat gain provided that the code does not require the glazing or fenestration assembly to be replaced.

N1111.1.1.1 (R503.1.1.1) Replacement fenestration. Where some or all of an existing fenestration unit is replaced with a new fenestration product, including sash and glazing, the replacement fenestration unit shall meet the applicable requirements for *U*-factor and SHGC as specified in Table N1102.1.3. **Where more than one replacement fenestration unit is to be installed, an area-weighted average of the *U*-factor, SHGC or both of all replacement fenestration units shall be an alternative that can be used to show compliance.**

N1111.1.2 (R503.1.2) Heating and cooling systems. **HVAC ducts newly installed as part of an *alteration* shall comply with Section N1103.**

Exception: Where ducts from an existing heating and cooling system are extended to an **addition.**

N1111.1.3 (R503.1.3) Service hot water systems. New service hot water systems that are part of the *alteration* shall comply with Section N1103.5.

N1111.1.4 (R503.1.4) Lighting. New lighting systems that are part of the *alteration* shall comply with Section N1104.1.

Exception: *Alterations* that replace less than **10** percent of the luminaires in a space, provided that such *alterations* do not increase the installed interior lighting power.

SECTION N1112 (R504) REPAIRS

N1112.1 (R504.1) General. *Buildings*, structures and parts thereof shall be repaired in compliance with Section N1109.3 and this section. Work on nondamaged components necessary for the required repair of damaged components shall be considered to be part of the *repair* and shall not be subject to the requirements for *alterations* in this chapter. Routine maintenance required by Section N1109.3, ordinary *repairs* exempt from *permit*, and abatement of wear due to normal service conditions shall not be subject to the requirements for *repairs* in this section.

N1112.2 (R504.2) Application. For the purposes of this code, the following shall be considered to be *repairs*:

1. Glass-only replacements in an existing sash and frame.
2. Roof *repairs*.
3. *Repairs* where only the bulb, ballast or both within the existing luminaires in a space are replaced provided that the replacement does not increase the installed interior lighting power.

SECTION N1113 (R505) CHANGE OF OCCUPANCY OR USE

N1113.1 (R505.1) General. Any space that is converted to a *dwelling unit* or portion thereof from another use or occupancy shall comply with this chapter.

Exception: Where the simulated performance option in Section N1105 is used to comply with this section, the annual energy cost of the *proposed design* is permitted to be 110 percent of the annual energy cost allowed by Section N1105.2.

N1113.1.1 (R505.1.1) Unconditioned space. Any unconditioned or low-energy space that is altered to become a conditioned space shall comply with Section N1108.

TABLE N1101.7 (R301.1)

~~CLIMATE ZONES, MOISTURE REGIMES, AND WARM HUMID DESIGNATIONS BY STATE, COUNTY AND TERRITORY^a~~

a. Key: A – Moist, B – Dry, C – Marine. Absence of moisture designation indicates moisture regime is irrelevant. Asterisk (*) indicates a Warm Humid location.

TABLE N1101.7 (R301.1)

~~CLIMATE ZONES, MOISTURE REGIMES, AND WARM HUMID DESIGNATIONS BY STATE, COUNTY AND TERRITORY^a~~

TABLE N1101.7 (R301.1)—continued

~~CLIMATE ZONES, MOISTURE REGIMES, AND WARM HUMID DESIGNATIONS BY STATE, COUNTY AND TERRITORY^a~~

(continued)

(continued)

TABLE N1101.7 (R301.1)—continued

~~CLIMATE ZONES, MOISTURE REGIMES, AND WARM HUMID DESIGNATIONS BY STATE, COUNTY AND TERRITORY^a~~

(continued)

Appendix O

FOAM PLASTIC DIAGRAMS

(Sections N1102.2.8.1 and N1102.2.9.1, (R402.2.9 and R402.2.10)

N1102.2.8.1 (R402.2.9) Basement walls. Insulation illustrations (Includes detailing from Section R402.2.10)

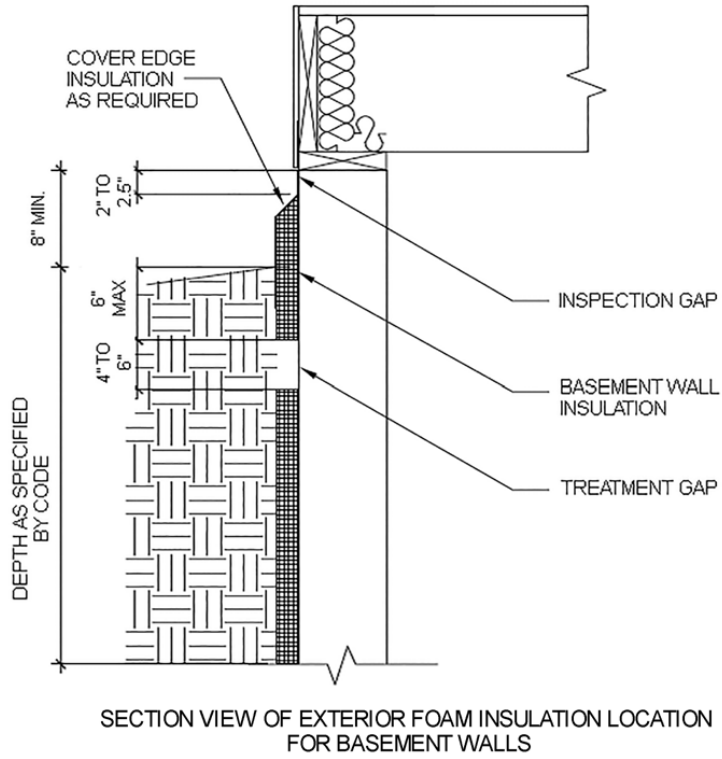

N1102.2.9.1 (R402.2.9.1) Slab-on-grade floors. Insulation illustrations

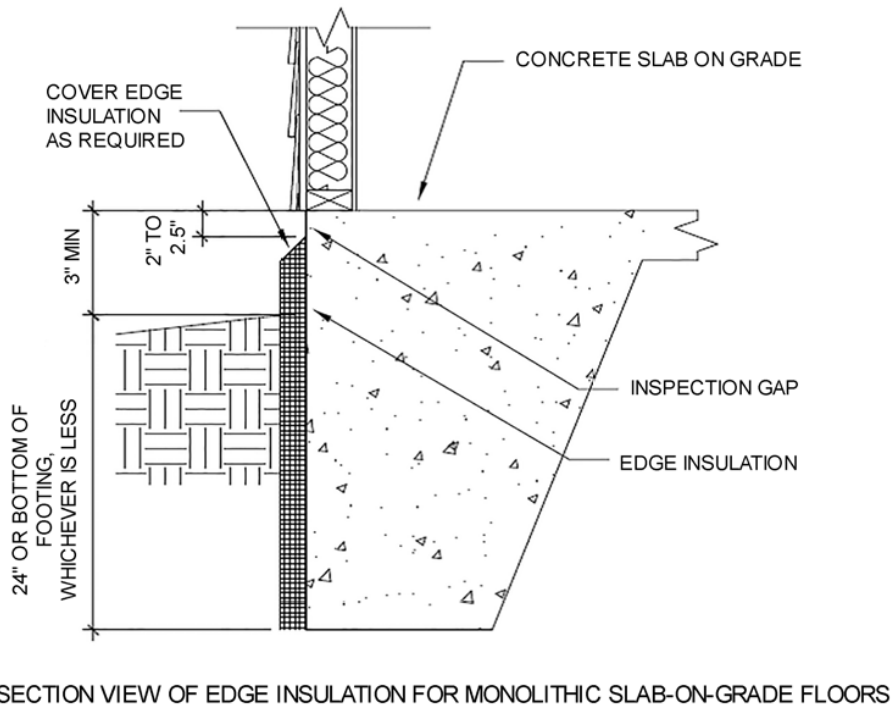

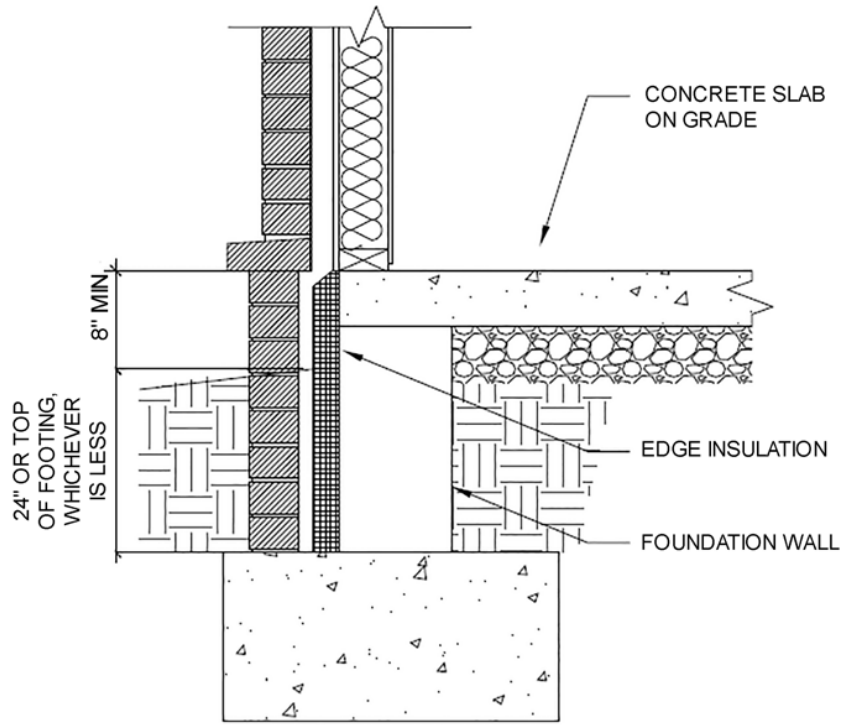

EXAMPLE FOR SLAB EDGE INSULATION LOCATION BEHIND
BRICK, STONE, OR MASONRY FACING

N1102.2.9.1 (R402.2.9.1) Slab-on-grade floors. Insulation illustrations – Floating Slab with Stem Wall

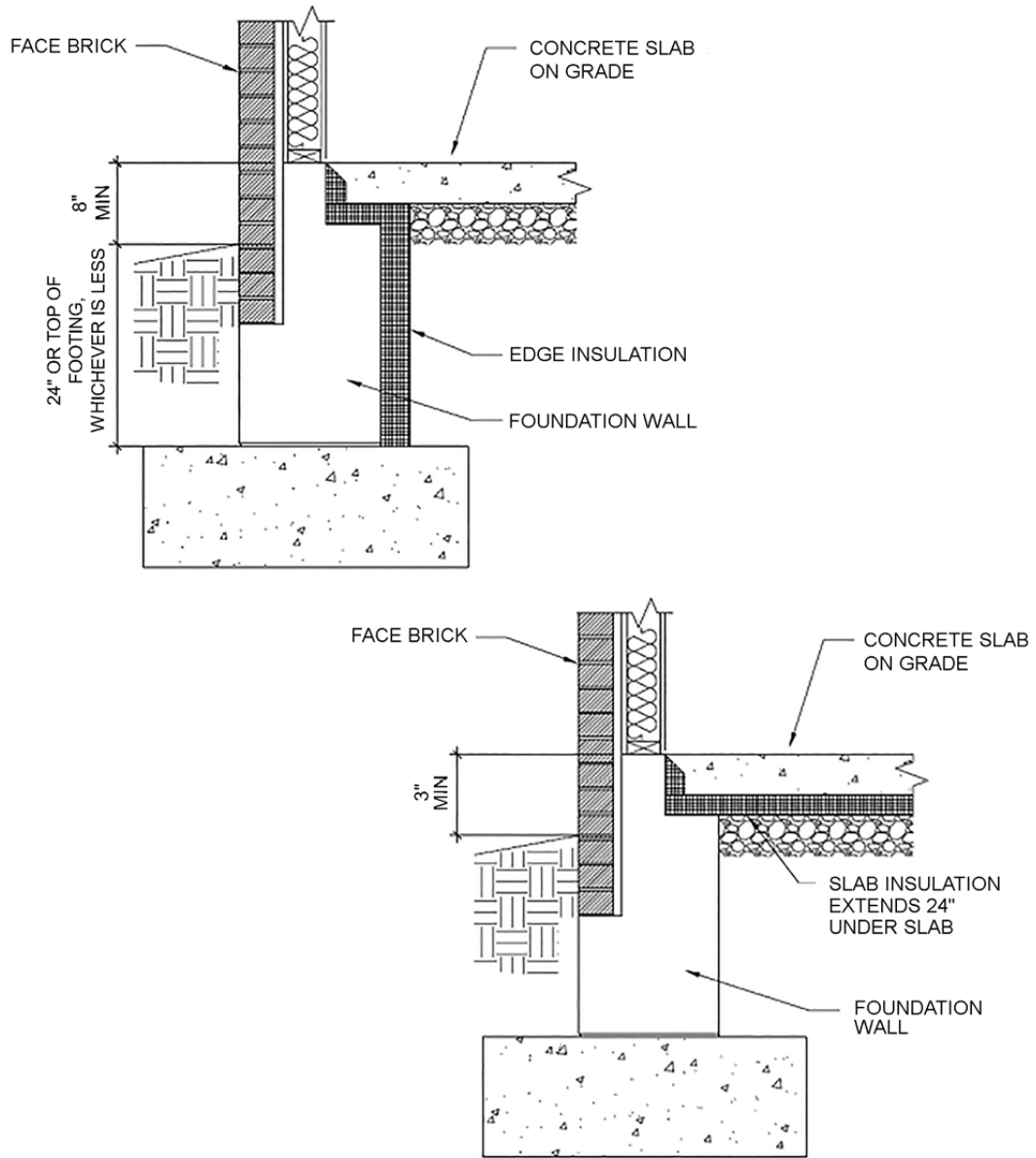

EXAMPLES FOR SLAB INSULATION LOCATION
FOR FLOATING SLAB WITH STEM WALL
(Options for brick facing are shown)

APPENDIX E
(E-1 through E-4)

RESIDENTIAL REQUIREMENTS for ENERGY CONSERVATION

This appendix is a North Carolina Appendix exclusive to the State of North Carolina, and not part of the 2021 International Residential Code. There will be no underlined text. (The provisions contained in this appendix are adopted as part of this code)

Appendix E-1 (R1.1) Energy Efficiency Certificate (Section N1101.14 (R401.3))

TABLE N1101.14 (R401.3)
ENERGY EFFICIENCY CERTIFICATE

Energy Efficiency Certificate – Code Edition Permitted under:	
Energy Code Compliance path used (Circle one): 1.Prescriptive 2.Total Building Performance 3.ERI	
Builder, Permit Holder or Registered Design Professional: Print Name: Signature:	
Property Address:	
Date:	
Insulation Rating – List the value covering largest area to all that apply	R-value
Ceiling/roof:	R-
Wall:	R-
Floor:	R-
Closed crawl space wall:	R-
Closed crawl space floor:	R-
Slab:	R-
Basement wall:	R-
Fenestration	
Fenestration (excluding skylights)	U- Uwa-
Fenestration (Skylights)	U- Uwa-
Solar Heat Gain Coefficient (SHGC)(All glazed fenestration)	SHGC - SHGCwa-
Building Air Leakage	
Building air leakage test results (See N1102.4.1.2, R402.4.1.2) Target value: 4.0 ACH@50; or See N1102.4 for alternate test pressures and leakage allowance values.	
Name of Tester/Company:	
Date of test:	Phone:
Ducts:	
Insulation	R-
Total Duct leakage test result (N1103.3.6, R403.3.6) Target value: 4.0 CFM per 100 sq. ft. of conditioned floor area, at test pressure of 0.1 inch of w.g. (25 Pascals); or 8.0 CFM per 100 sq. ft. of conditioned floor area, at test pressure of 0.1 inch of w.g. (25 Pascals) if all ductwork is within building thermal envelope	
Name of Tester or Company:	
Date of Test:	Phone:
Heating/Cooling Equipment	
Type(s): Size(s) Btu/hr: Fuel-fired Efficiency: Heat pump and/or AC SEER, HSPF:	
Water heating	

Type(s)	Size(s) (Watts or Btu/hr):	Fuel fired efficiency:	Heat pump Water heater COP:
Where a gas-fired unvented room heater, electric furnace or baseboard electric heater is installed in the residence, the certificate shall indicate "gas-fired unvented room heater," "electric furnace" or "baseboard electric heater," as appropriate:			
Energy Rating Index:			
If, and only if the ERI pathway was used, write the ERI Score:			
Without On-Site generation:		With On-Site generation (if applicable):	
Certificate to be displayed permanently- per N1101.14 (R401.3)			

APPENDIX E-2 INSULATION AND AIR SEALING DETAILS

APPENDIX E2.1 (Section R402.2.1)

N1102.2.1 (R402.2.1) Ceilings with attic spaces: Allowance for reduced insulation if full-height insulation is provided over the wall top plate at the eaves.

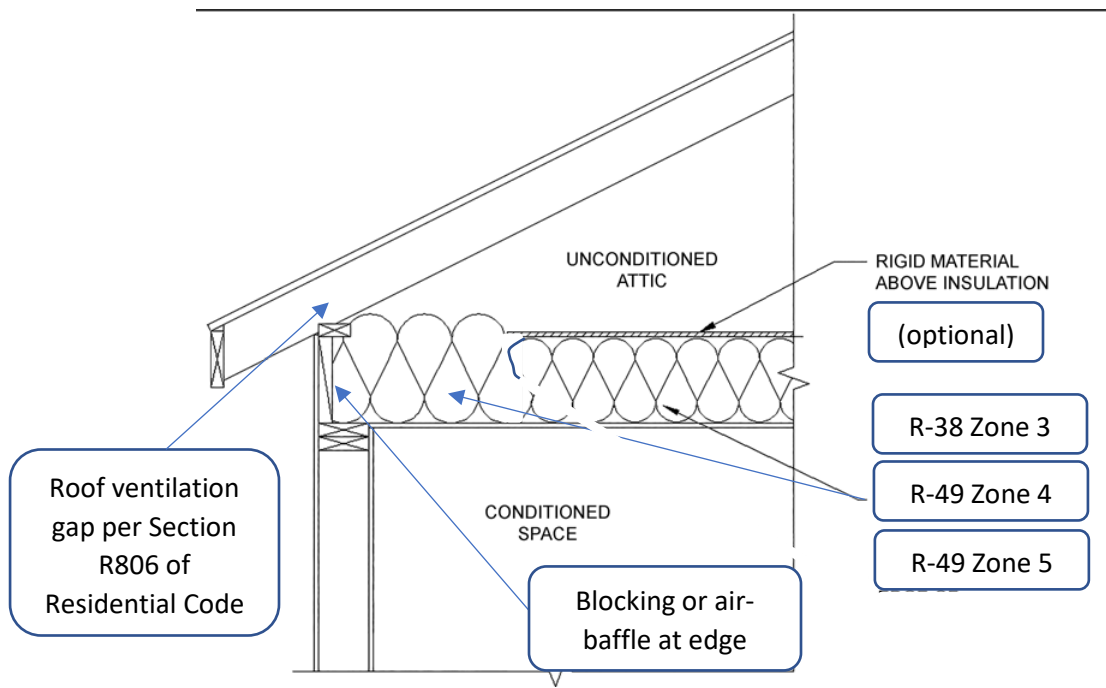

N1102.2.1 R402.2.1 Ceilings with attic spaces: Allowance for reduced insulation if full-height insulation is provided over the walls eaves – Optional method, Formerly “Fully enclosed attic floor assembly-2018 NC ECC”

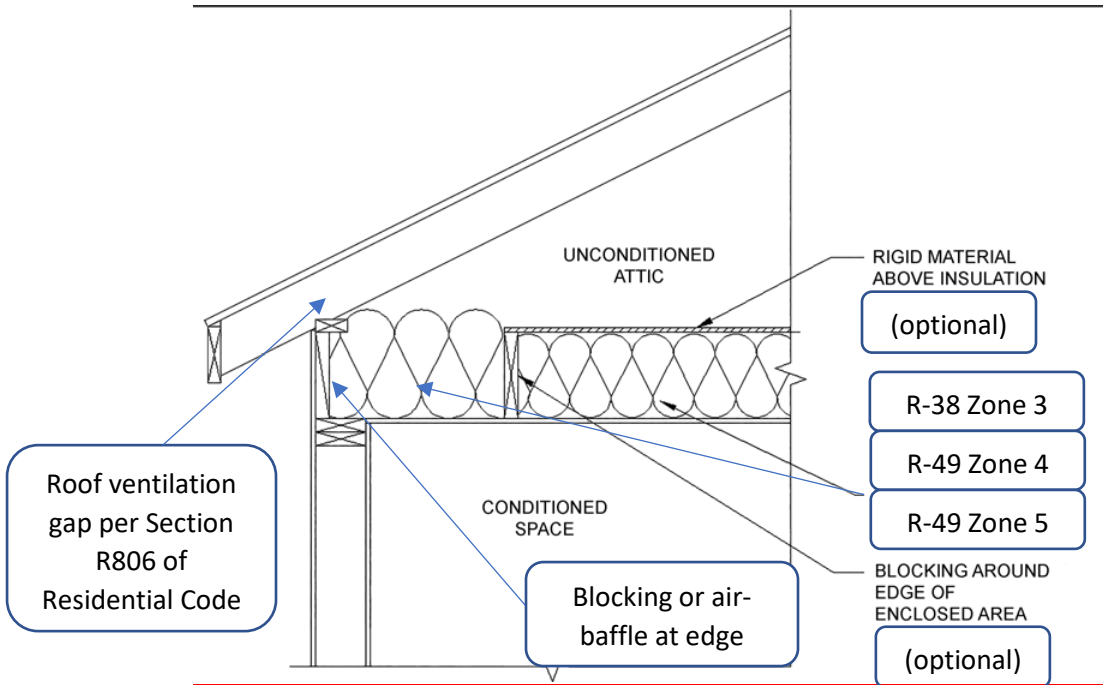

(R402.2.1) Ceilings with attic spaces: Exception for fully enclosed attic floor systems.

APPENDIX E-2.2 (Section R402.2.10)

N1102.2.10 (R402.2.10) Closed crawl space walls. Insulation illustrations.

FOAM OR POROUS INSULATION HAS 3" TO 4" TOP INSPECTION GAP AND EXTENDS DOWN 3" TO 4" ABOVE TOP OF WALL FOOTING OR CONCRETE FLOOR

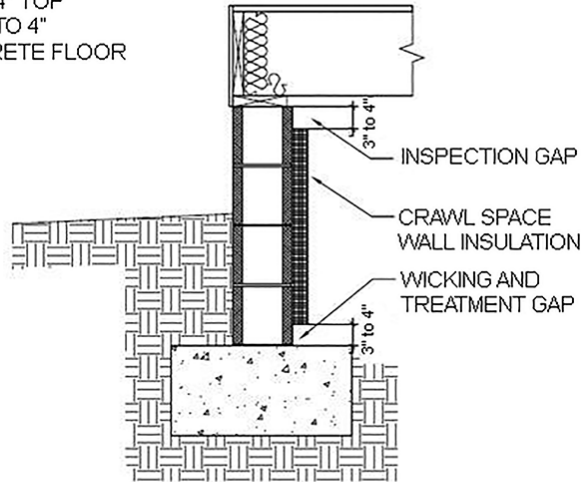

FOAM OR POROUS INSULATION HAS 3" TO 4" TOP INSPECTION GAP AND EXTENDS DOWN 24" BELOW GRADE

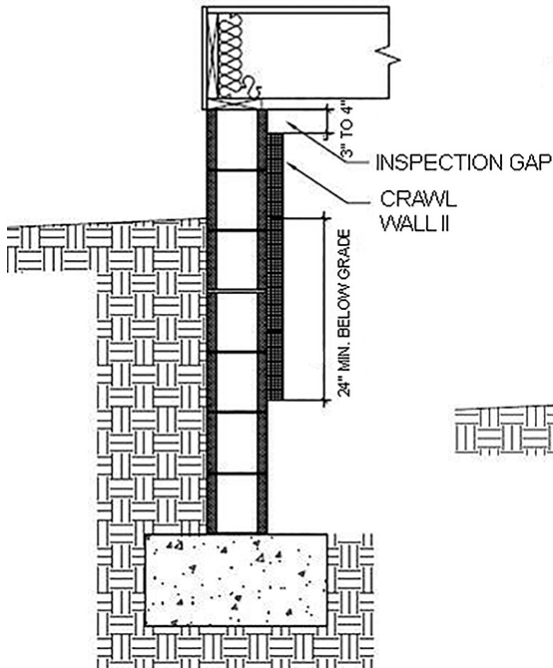

FOAM OR POROUS INSULATION HAS 3" TO 4" TOP INSPECTION GAP AND EXTENDS DOWN 3" TO 4" ABOVE INTERIOR GROUND SURFACE

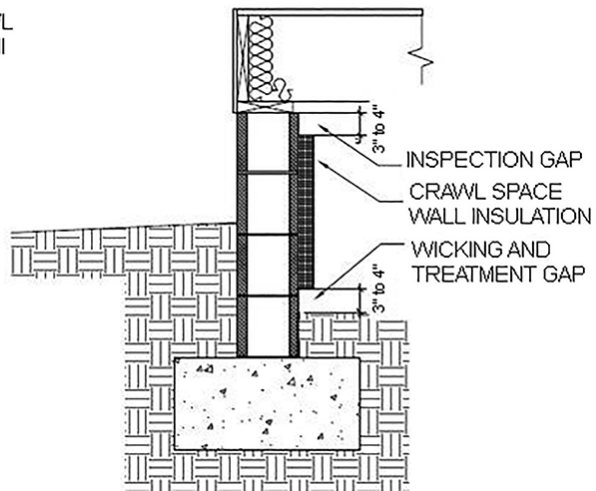

APPENDIX E-2.3 (Section R402.4.1.1, Table R402.4.1.1)

Table 1102.4.1.1 (R402.4.1.1) Air Barrier, Air Sealing and Insulation Installation. Shower/Tub on exterior wall

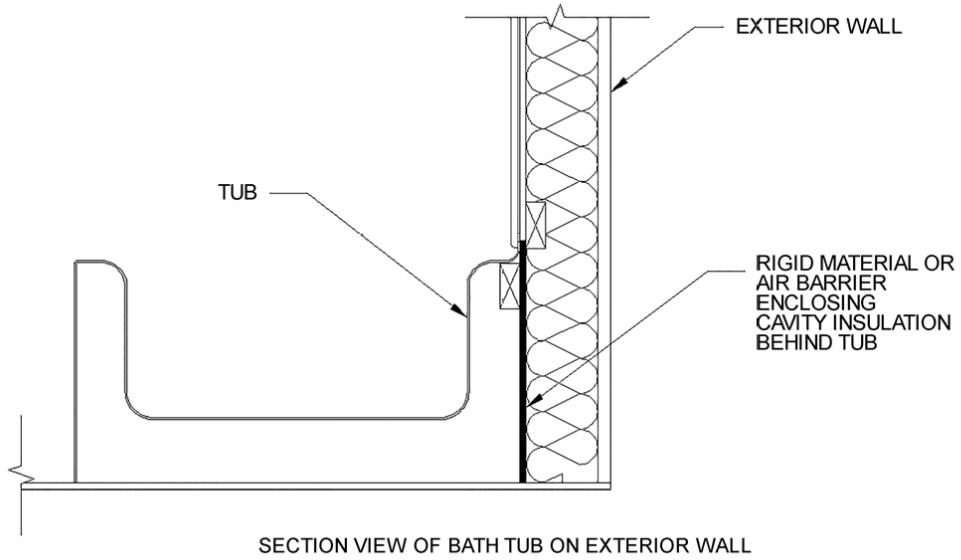
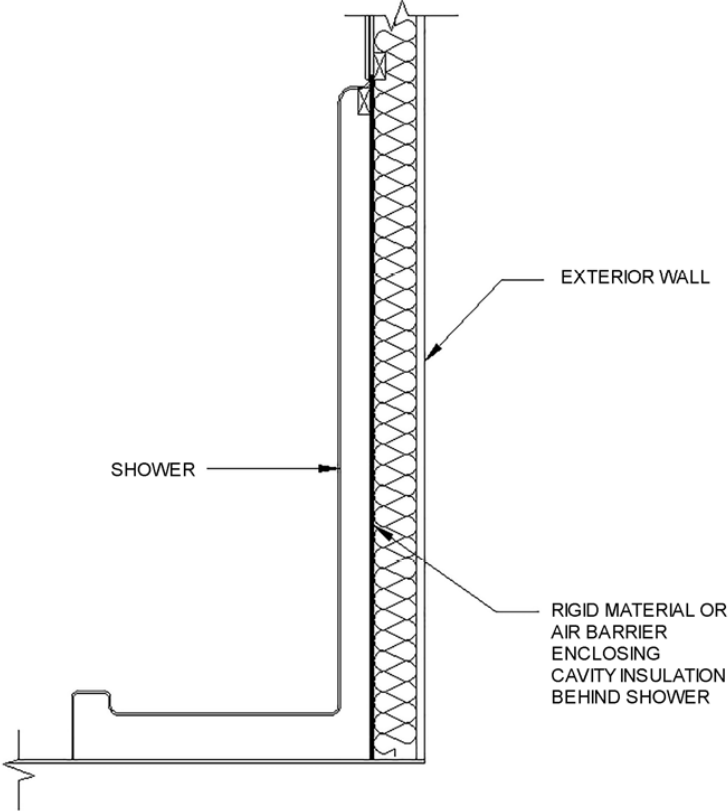

Table 1102.4.1.1 (R402.4.1.1) Air Barrier, Air Sealing and Insulation Installation. Shower/tub on exterior wall



SECTION VIEW OF SHOWER ON EXTERIOR WALL

Table 1102.4.1.1 (R402.4.1.1) Air Barrier, Air Sealing, and Insulation Installation – General Requirements

Note to ad hoc committee:

This is requirement not specifically mentioned anymore. If the sheathing is used as the air barrier, this would not be a requirement - DED

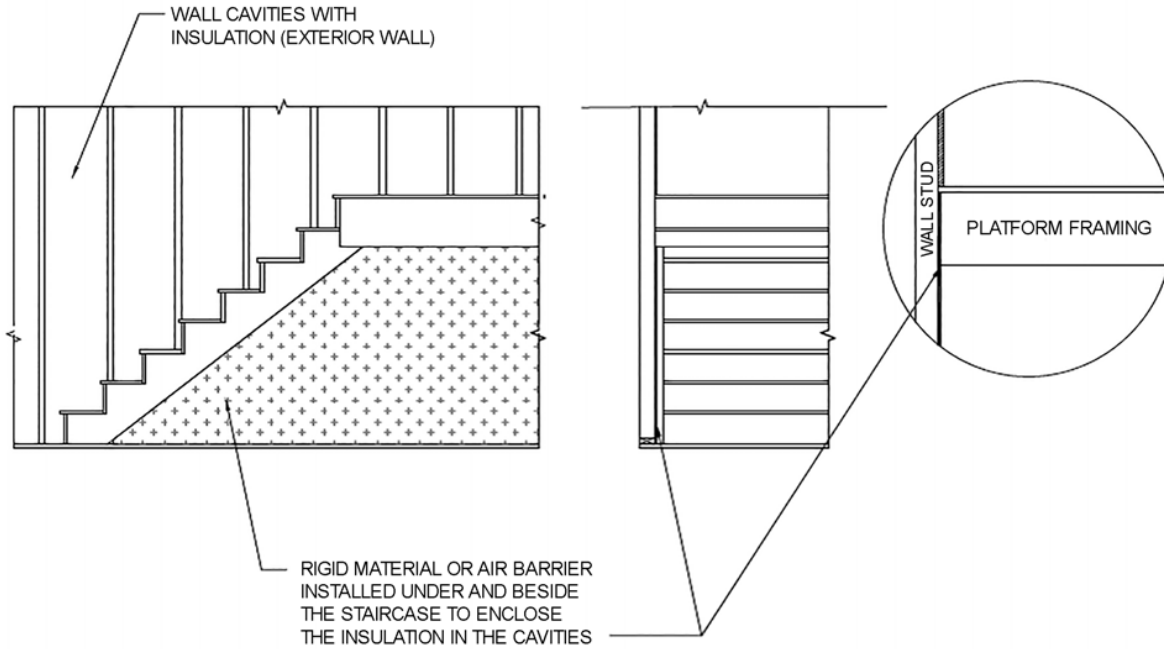

SECTION VIEW OF INTERIOR STAIRCASE ON EXTERIOR WALL (OPTION 1)

Table 1102.4.1.1 (R402.4.1.1) Air Barrier, Air Sealing, and Insulation Installation – General Requirements

Note to ad hoc committee:

This is requirement not specifically mentioned anymore. If the sheathing is used as the air barrier, this would not be a requirement - DED

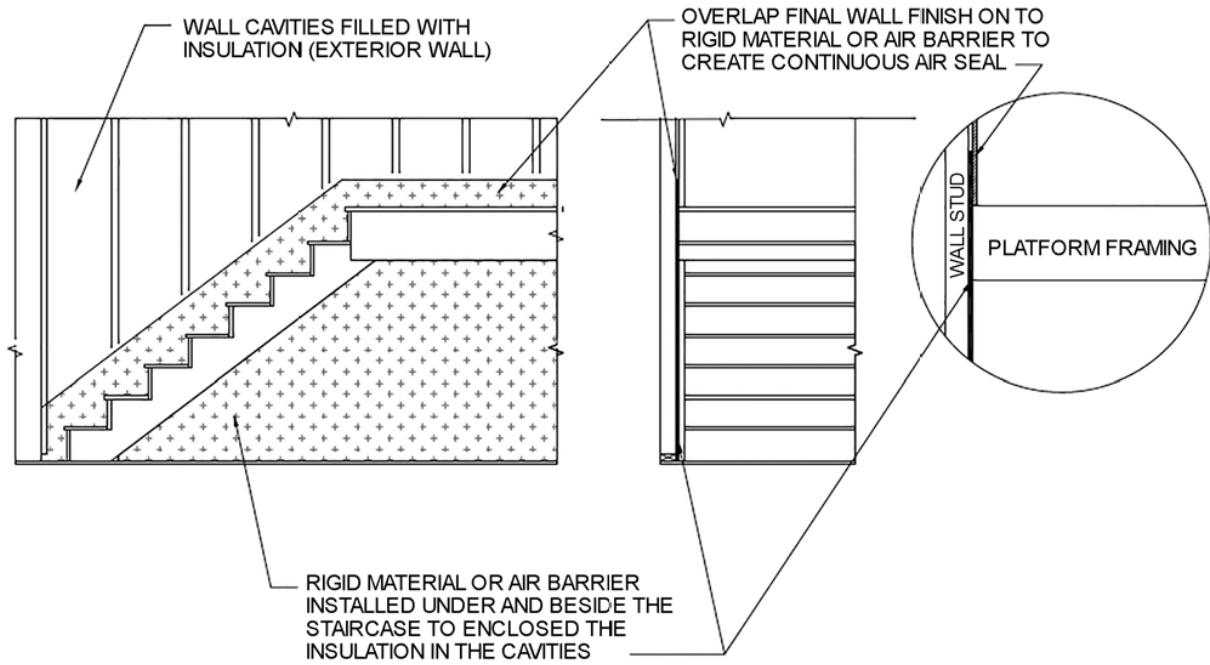

SECTION VIEW OF INTERIOR STAIRCASE ON EXTERIOR WALL (OPTION 2)

Table 1102.4.1.1 (R402.4.1.1) Air Barrier, Air Sealing, and Insulation Installation – Shafts, penetrations. Flue Shaft.

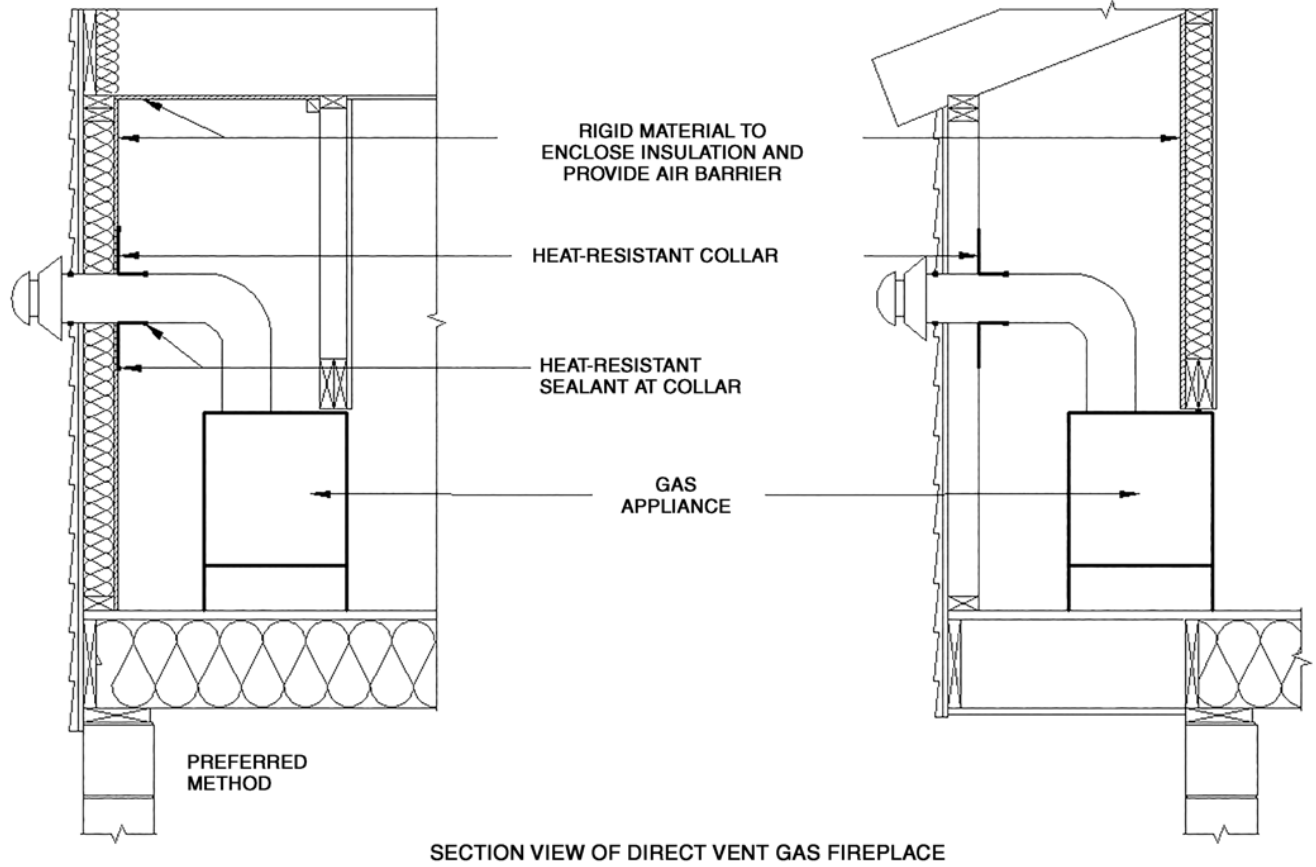
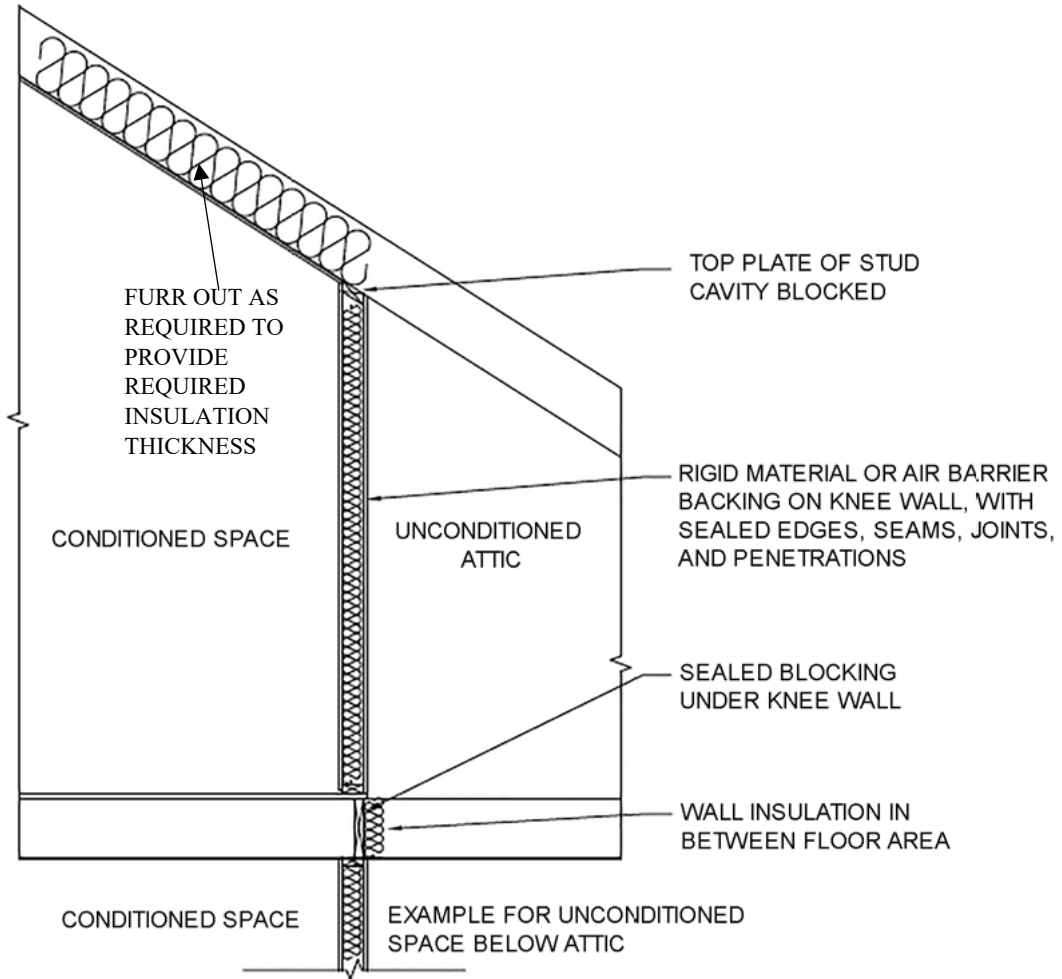
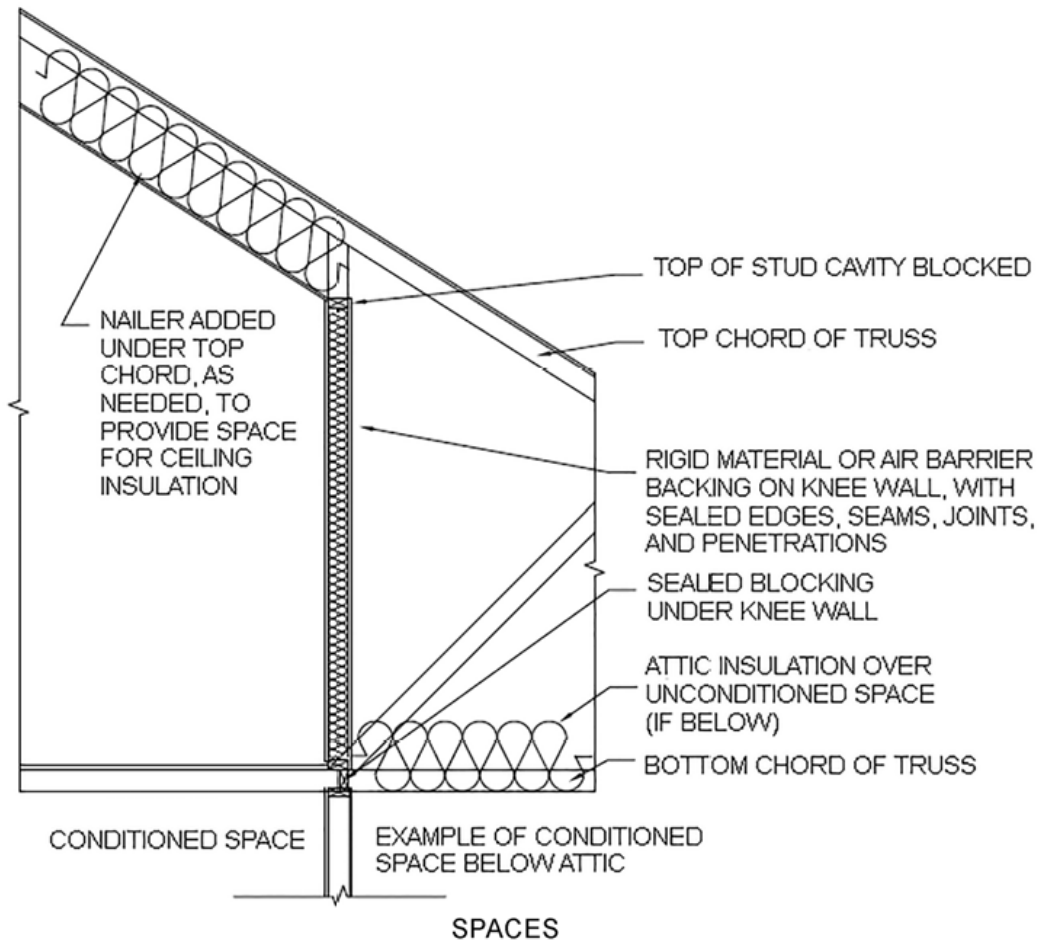

Table 1102.4.1.1 (R402.4.1.1) Air Barrier, Air Sealing, and Insulation Installation – Walls, Knee walls, stick framed roof



SECTION VIEW OF WALL ADJOINING ATTIC SPACE WITH STICK FRAMED ROOF

Table 1102.4.1.1 (R402.4.1.1) Air Barrier, Air Sealing, and Insulation Installation – Walls, Knee walls, trusses



SECTION VIEW OF WALL ADJOINING ATTIC SPACE WITH TRUSS ROOF

Table 1102.4.1.1 (R402.4.1.1) Air Barrier, Air Sealing, and Insulation Installation – Cantilevered floor – dimensional lumber

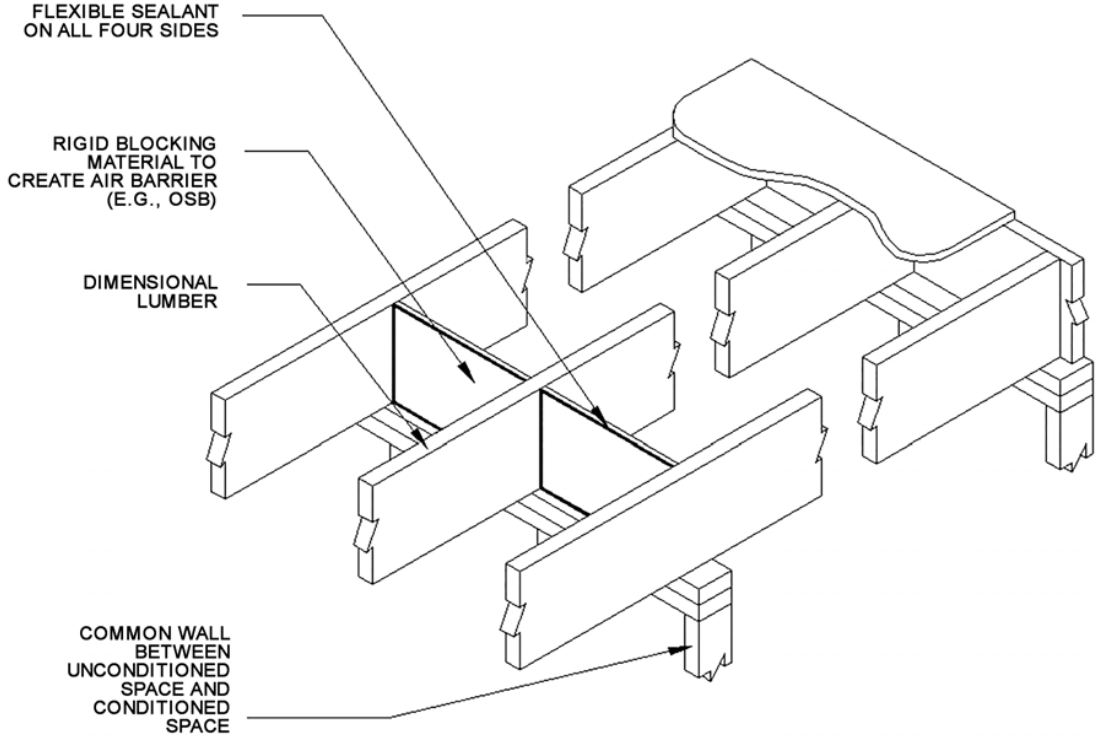

ISOMETRIC VIEW OF DIMENSIONAL LUMBER FLOOR/CEILING SYSTEM ABOVE COMMON WALL BETWEEN UNCONDITIONED AND CONDITIONED SPACE

Table 1102.4.1.1 (R402.4.1.1) Air Barrier, Air Sealing, and Insulation Installation – Cantilevered floor – floor trusses

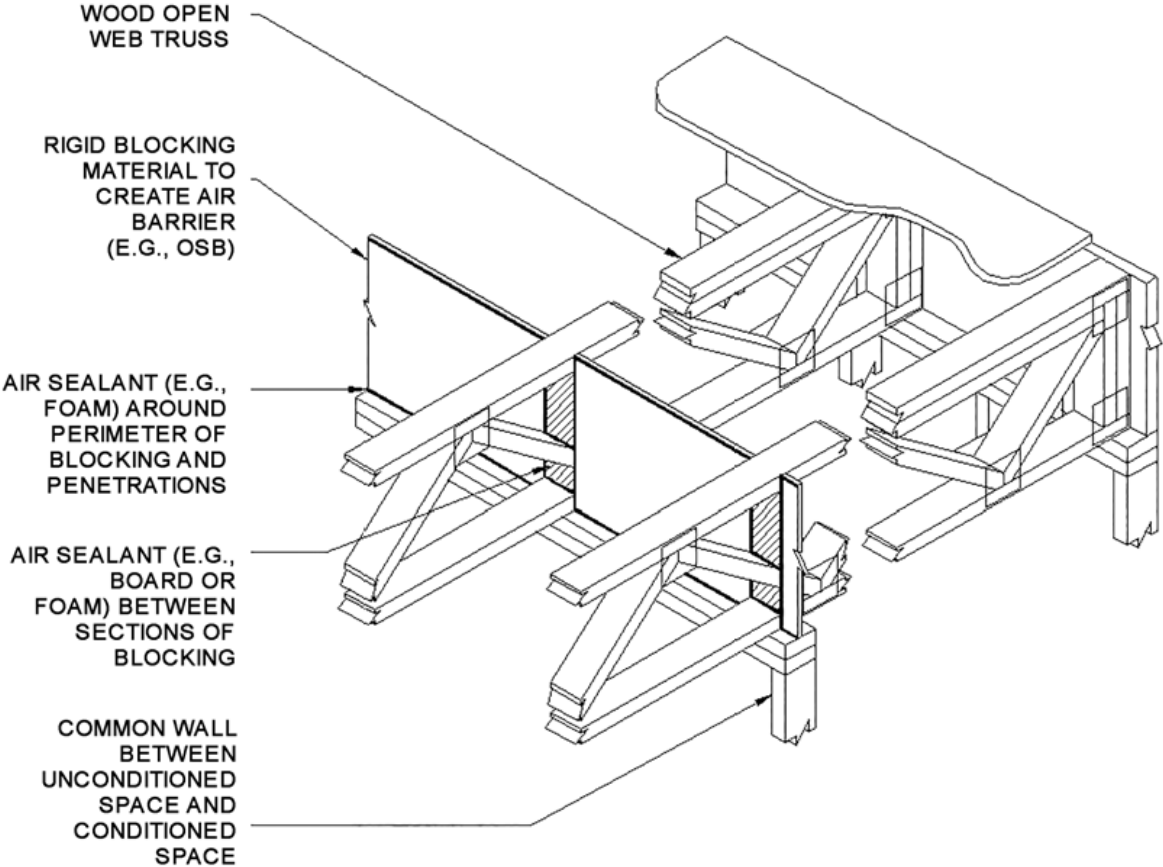

ISOMETRIC VIEW OF WOOD TRUSS FLOOR/CEILING SYSTEM ABOVE COMMON WALL BETWEEN UNCONDITIONED AND CONDITIONED SPACE

Table 1102.4.1.1 (R402.4.1.1) Air Barrier, Air Sealing, and Insulation Installation – Cantilevered floor – I-joists

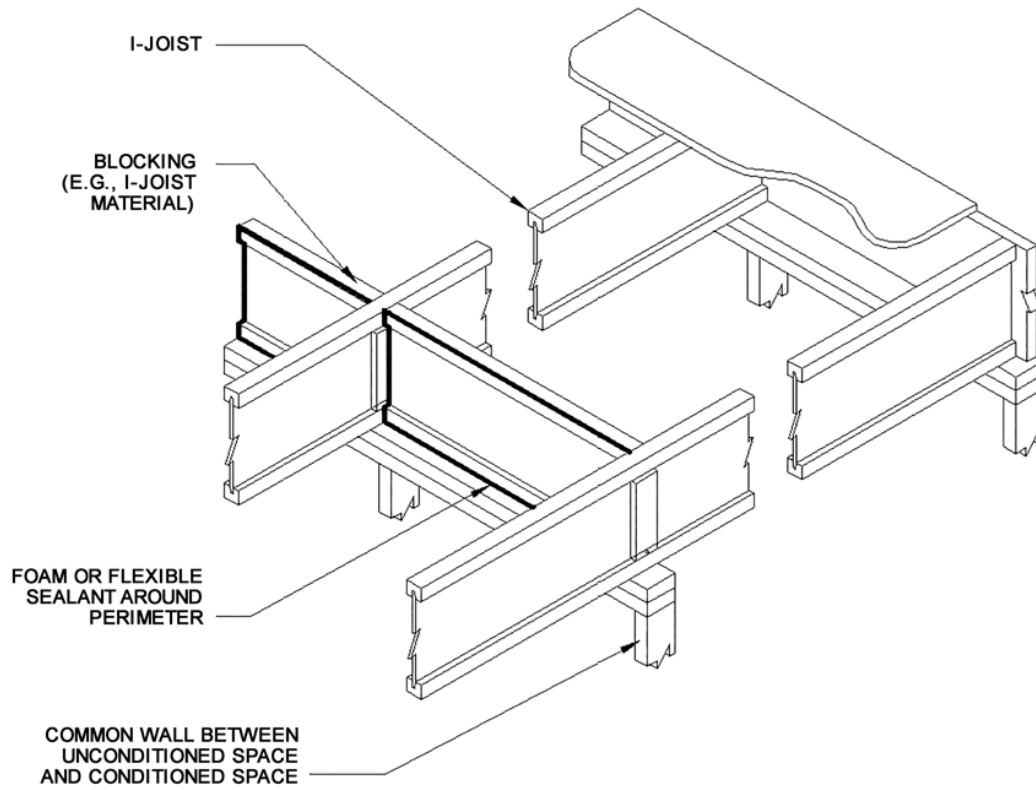

ISOMETRIC VIEW OF I-JOIST FLOOR/CEILING SYSTEM ABOVE COMMON WALL BETWEEN UNCONDITIONED AND CONDITIONED SPACE

Table 1102.4.1.1 (R402.4.1.1) Air Barrier, Air Sealing, and Insulation Installation – Shafts, penetrations

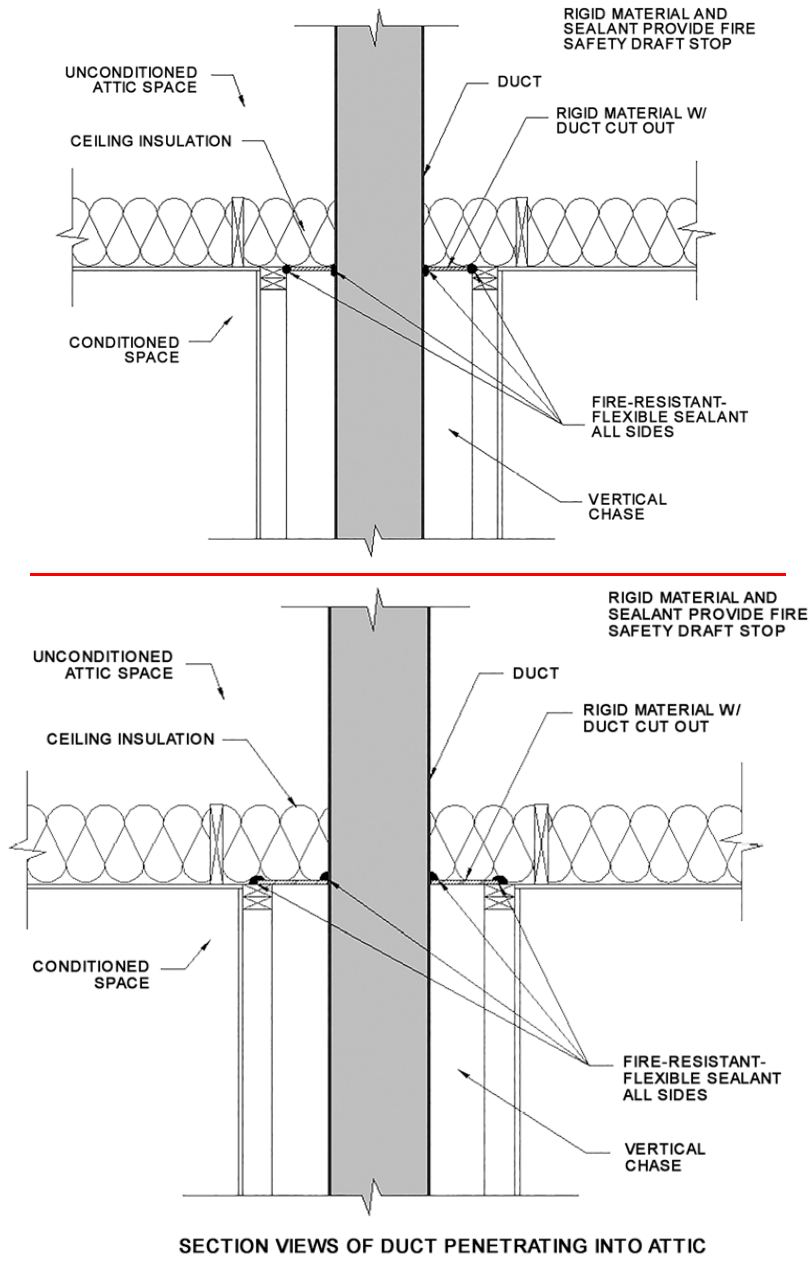
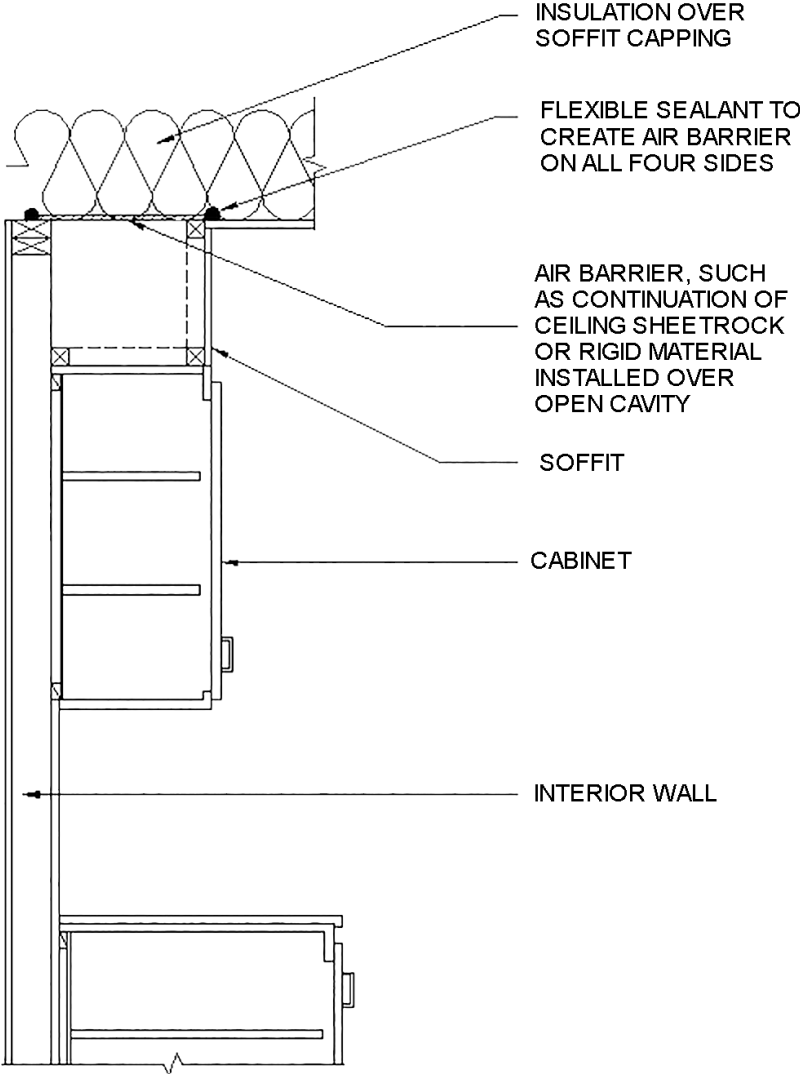
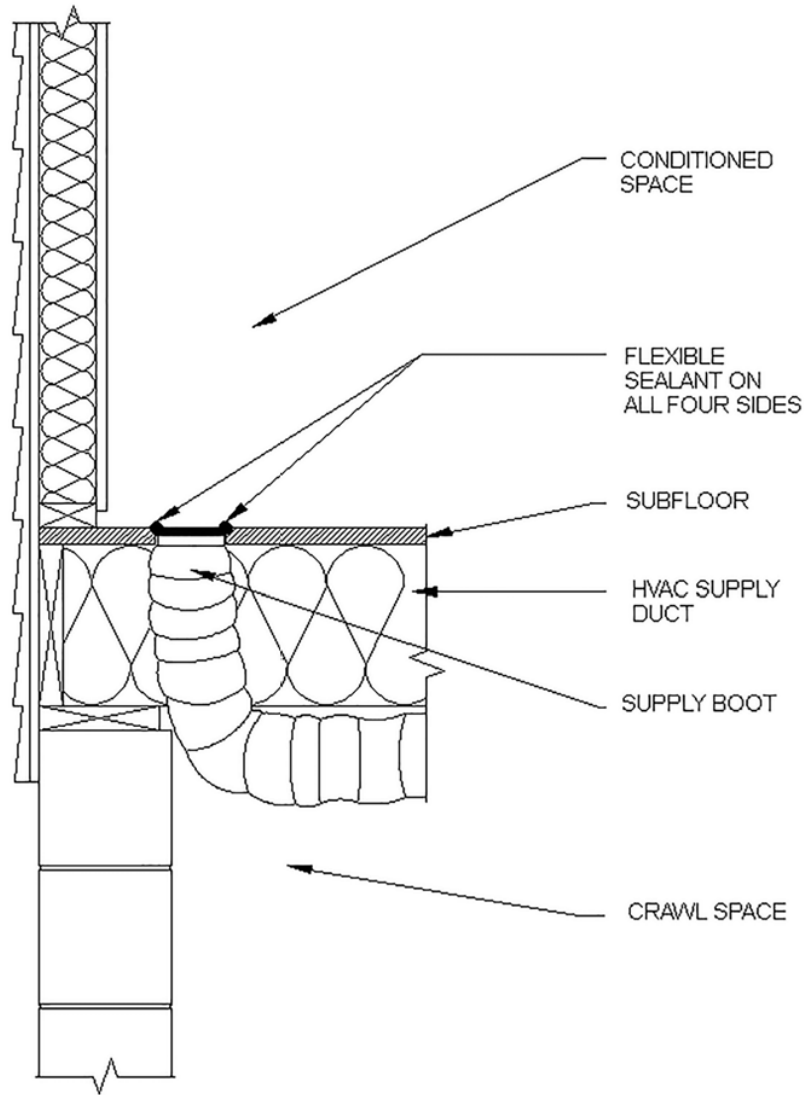

Table 1102.4.1.1 (R402.4.1.1) Air Barrier, Air Sealing, and Insulation Installation – Ceiling/attic – dropped soffit



SECTION VIEW OF SOFFIT OVER CABINET

Table 1102.4.1.1 (R402.4.1.1) Air Barrier, Air Sealing, and Insulation Installation – HVAC register boots - floor



SECTION VIEW OF FLOOR HVAC BOOT PENETRATION

Table 1102.4.1.1 (R402.4.1.1) Air Barrier, Air Sealing, and Insulation Installation – HVAC register boots - ceiling

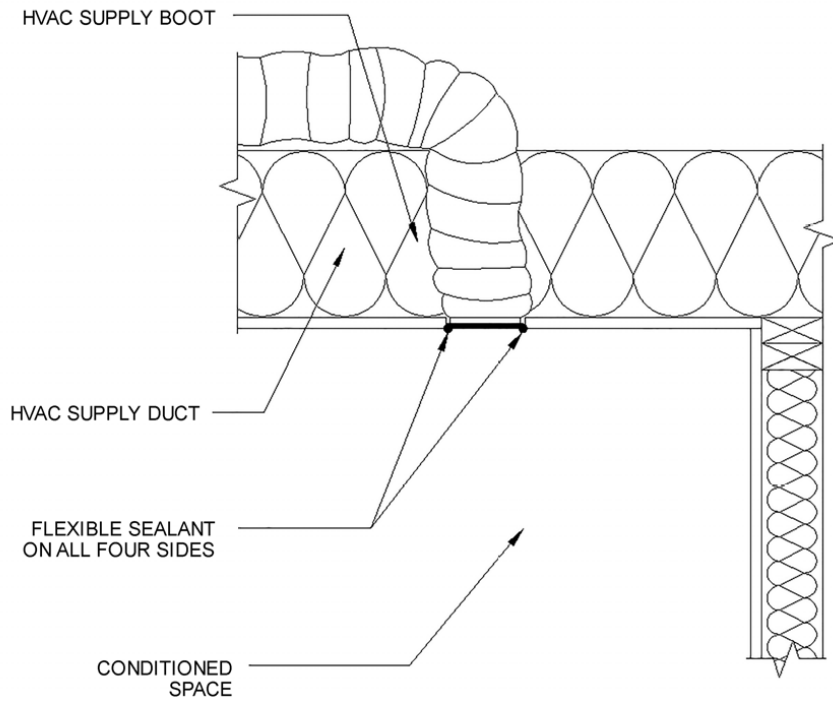

SECTION VIEW OF CEILING HVAC BOOT PENETRATION

Table 1102.4.1.1 (R402.4.1.1) Air Barrier, Air Sealing, and Insulation Installation – General requirements – housewrap option

Follow manufacturer’s instructions for sealing air barrier-rated housewrap, including choice of materials, to provide an exterior air barrier at the following locations:

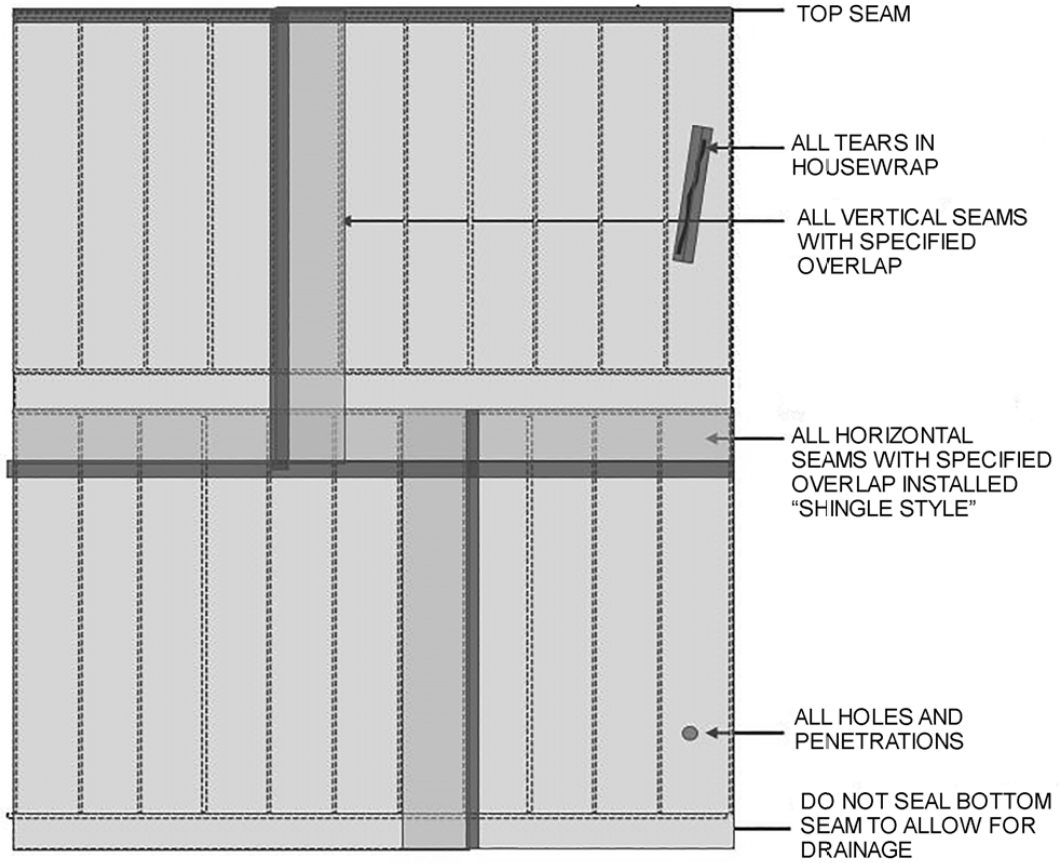
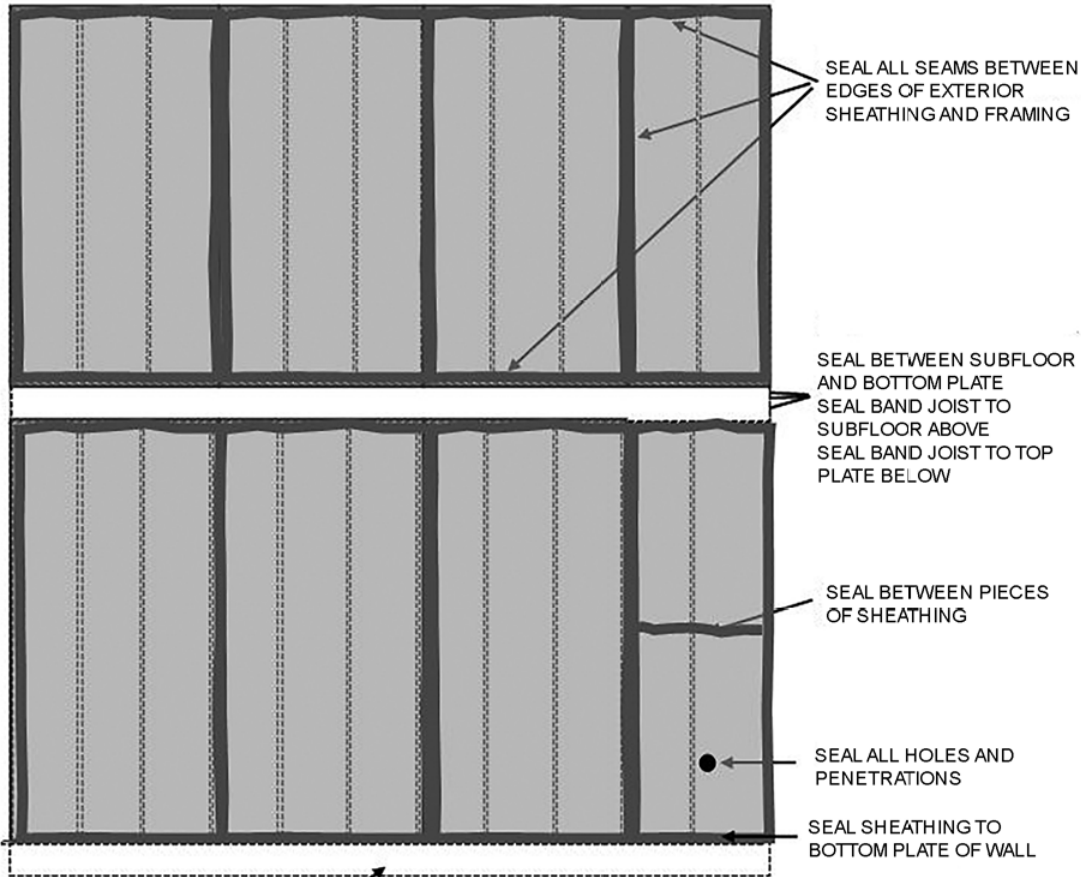

Table R402.4.1.1 Air Barrier, Air Sealing, and Insulation Installation – General requirements – sealed sheathing option



- 1) IF FIRST FLOOR IS SLAB-ON-GRADE, INSTALL SEAL SEALER UNDER BOTTOM PLATE OF EXTERIOR WALL.
- 2) IF FIRST FLOOR IS OVER UNCONDITIONED CRAWL SPACE OR BASEMENT, INSTALL SEAL SEALER UNDER BOTTOM PLATE AND SEAL SUBFLOOR TO BAND JOIST.
- 3) IF FIRST FLOOR IS OVER CONDITIONED BASEMENT OR CLOSED CRAWL SPACE WITH CRAWL SPACE WALL INSULATION BELOW, SEAL BETWEEN SUBFLOOR AND BOTTOM PLATE, SEAL BAND JOIST TO SUBFLOOR ABOVE, AND SEAL BAND JOIST TO TOP PLATE BELOW.

Table 1102.4.1.1 (R402.4.1.1) Air Barrier, Air Sealing, and Insulation Installation – Plumbing, wiring, or other obstructions – Exhaust fan

R402.4.2.1 Visual inspection option. — Table R402.4.2 Seal ceiling mechanical box penetrations

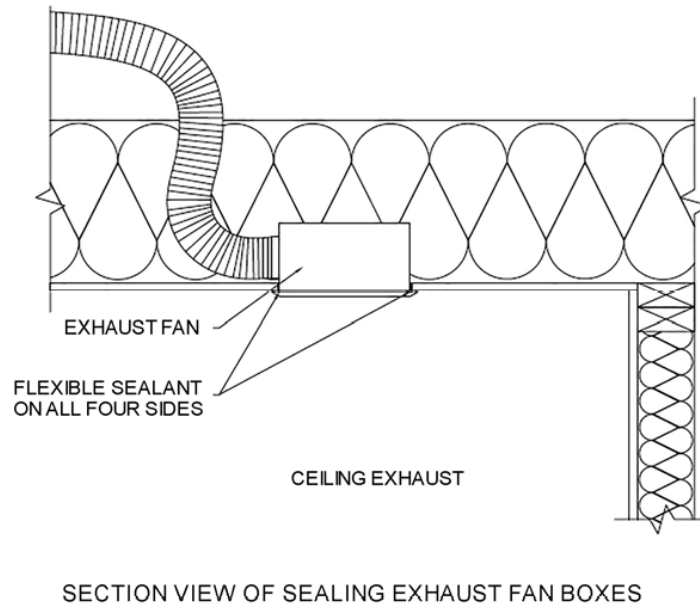

1102.4.5 (R402.4.5) Electrical and communication outlet boxes – field-sealed

R402.4.2.1 Visual inspection option. — Table R402.4.2 Seal ceiling electrical box penetrations

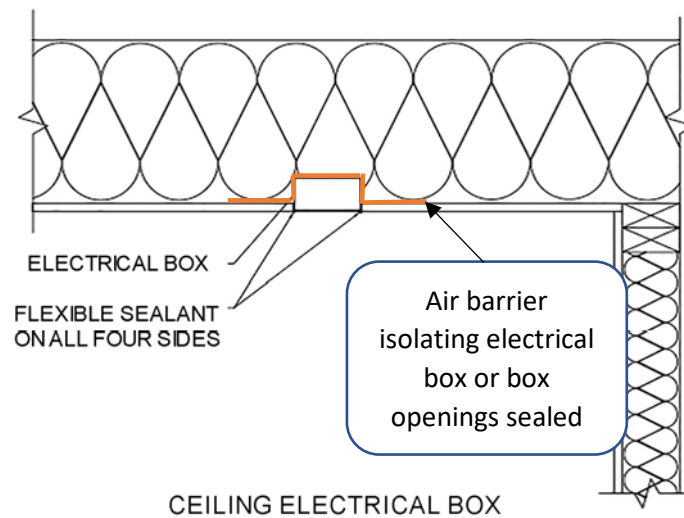

1102.4.5 (R402.4.5) Electrical and communication outlet boxes – NEMA OS 4

R402.4.2.1 Visual inspection option. — Table R402.4.2 Seal ceiling electrical box penetrations

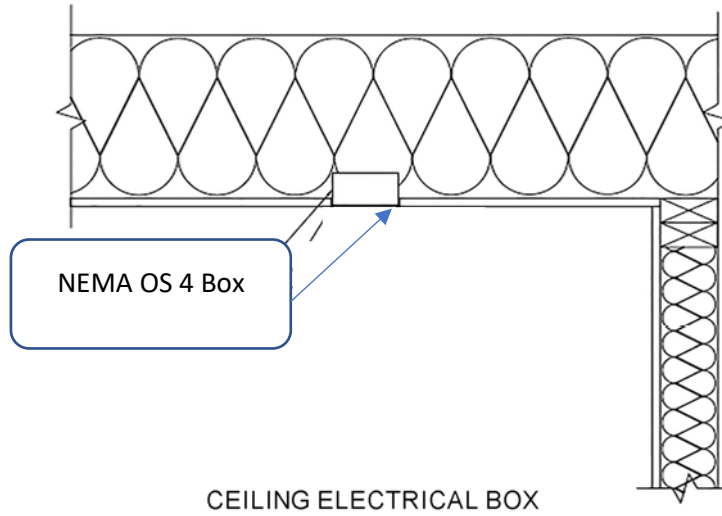

**SAMPLE WORKSHEETS FOR RESIDENTIAL AIR
AND DUCT LEAKAGE TESTING**

APPENDIX E-3A R3A

**Air sealing: Visual inspection option (Section N1102.4.2.1 (R402.4.2.1))
Sample Worksheet**

R402.4.2 Air sealing. Building envelope air tightness shall be demonstrated by compliance with Section R402.4.2.1 or R402.4.2.2.

R402.4.2.1 Visual inspection option. Building envelope tightness shall be considered acceptable when items providing insulation enclosure in Section R402.2.14 and enclosure and air sealing in Section R402.2.15 and air sealing in Section R402.4.1 are addressed and when the items listed in Table R402.4.2, applicable to the method of construction, are certified by the builder, permit holder or registered design professional via the certificate in Appendix R1.1.

COMPONENT	CRITERIA
Ceiling/attic	Sealants or gaskets provide a continuous air barrier system joining the top plate of framed walls with either the ceiling drywall or the top edge of wall drywall to prevent air leakage. Top plate penetrations are sealed. For ceiling finishes that are not air barrier systems such as tongue and groove planks, air barrier systems (for example, taped house wrap), shall be used above the finish. Note: It is acceptable that sealants or gaskets applied as part of the application of the drywall will not be observable by the code official.
Walls	Sill plate is gasketed or sealed to subfloor or slab.
Windows and doors	Space between window and exterior door jambs and framing is sealed.
Floors (including above garage and cantilevered floors)	Air barrier system is installed at any exposed edge of insulation.
Penetrations	Utility penetrations through the building thermal envelope, including those for plumbing, electrical wiring, ductwork, security and fire alarm wiring, and control wiring, shall be sealed.
Garage separation	Air sealing is provided between the garage and conditioned spaces. An air barrier system shall be installed between the ceiling system above the garage and the ceiling system of interior spaces.
Ceiling penetrations	Ceiling electrical box penetrations and ceiling mechanical box penetrations shall be caulked, gasketed, or sealed at the penetration of the ceiling finish. See Appendix R1.2.4. Exception: Ceiling electrical boxes and ceiling mechanical boxes not penetrating the building thermal envelope.
Recessed lighting	Recessed light fixtures are air tight, IC-rated, and sealed to drywall. Exception: Fixtures in conditioned space.

Property Address:

R402.4.2.1 Visual Inspection Option

The inspection information including tester name, date, and contact shall be included on the certificate described in Section R401.3.

Signature

Date

APPENDIX E-3B
Air sealing: Testing Section N1102.4.1.2 (R402.4.1.2)
Sample Worksheet – 4.0 ACH Requirement

R402.4.1.2 Testing. The *building or dwelling unit* shall be tested **for air leakage**. Testing shall be conducted in accordance with **ANSI/RESNET/ICC 380, ASTM E779 or ASTM E1827** and reported at a pressure of 0.2 inch w.g. (50 Pascals). **If testing at a pressure of 75 Pa (0.30 in w.g.), Table Appendix E-3B N1102.4.1.2 shall be used for corresponding maximum allowed leakage.** Where required by the *code official*, testing shall be conducted by an *approved* third party. A written report of the results of the test shall be signed by the party conducting the test and provided to the *code official*. Testing shall be performed at any time after creation of all penetrations of the *building thermal envelope* **have been sealed**.

- The maximum air leakage rate for any *building or dwelling unit* under any compliance path shall not exceed 4.0 air changes per hour (Test Criteria 1) or 0.23 cubic feet per minute (CFM) per square foot [0.0079 m³/(s × m²)] (Test Criteria 2) of dwelling unit enclosure area.
 - Warning: The 4.0 ACH threshold is a maximum for any compliance path, if following Section R401.2.1, 4.0 ACH is not allowed. See following section for requirements of R401.2.1
- When complying with Section R401.2.1, the building or dwelling unit shall have an air leakage rate not exceeding 3.0 air changes per hour in Climate Zones 3 through 5 when tested in accordance with Section R402.4.1.2. See APPENDIX R3B1 for Sample.

Table Appendix E-3B N1102.4.1.2 Adjustment for different test pressures

Pressure Differential (Pa)	Test pressure Adjustment Factor	Max Air Leakage / Building Thermal Envelope (CFM / ft ²)					
		0.25	0.28	0.30	0.35	0.372	0.40
75 (0.30 in. w.g.)							
50 (0.20 in. w.g.)	0.752897957	0.19	0.21	0.23	0.26	0.28	0.30

Example: If maximum air leakage allowed is 0.28 cfm/SF of bldg thermal envelope at 50 Pa(0.2 in w.g.), the corresponding maximum leakage rate is 0.372 cfm/SF of bldg thermal envelope if using a test pressure of 75 Pa(0.3 in w.g.)

Testing shall be reported by the permit holder, a North Carolina licensed general contractor, a North Carolina licensed HVAC contractor, a North Carolina licensed Home Inspector, a *registered design professional*, a certified *BPI Envelope Professional* or a certified *HERS rater*.

During testing:

1. Exterior windows and doors, fireplace and stove doors shall be closed, but not sealed;
2. Dampers shall be closed, but not sealed, including exhaust, backdraft, and flue dampers;
3. Interior doors shall be open;
4. Exterior openings for continuous ventilation systems, air intake ducted to the return side of the conditioning system, and energy or heat recovery ventilators shall be closed and sealed;
5. Heating and cooling system(s) shall be turned off; and
6. Supply and return registers shall not be sealed.

The air leakage information, building air leakage result, tester name, date, and contact information, shall be included on the certificate described in Section R401.3.

For Test Criteria 1 above, the report shall be produced in the following manner: Perform a blower door test and record the

CFM50 _____. Multiply the CFM50 by 60 minutes to create CFHour50 and record _____. Then calculate the total conditioned volume of the home and record _____. Divide the CFH50 by the total volume and record the result below. If the result is less than or equal to [4.0 ACH50] the envelope tightness is acceptable.

For Test Criteria 2 above, the report shall be produced in the following manner: Perform the blower door test and record the CFM50 _____. Calculate the total square feet of surface area for the building thermal envelope (all floors, ceilings, and walls including windows and doors, bounding conditioned space) and record the area _____. Divide CFM50 by the total square feet and record the result below. If the result is less than or equal to [0.23 CFM50/SFSA] the envelope tightness is acceptable.

Property Address: _____

Fan attachment location _____ Company Name _____

Contact Information: _____

Signature of Tester _____ Date _____

Duct testing shall be performed and reported by a certified BPI Envelope Professional, a certified HERS rater, or other certified third-party professional trained in duct leakage testing by the test equipment manufacturer.

(circle one)

APPENDIX E-3B1
Air sealing: Testing Section N1102.4.1.2 (R402.4.1.2))
Sample Worksheet - 3.0 ACH Requirement

R402.4.1.2 Testing. The *building or dwelling unit* shall be tested **for air leakage**. Testing shall be conducted in accordance with **ANSI/RESNET/ICC 380, ASTM E779 or ASTM E1827** and reported at a pressure of 0.2 inch w.g. (50 Pascals). Where required by the *code official*, testing shall be conducted by an *approved* third party. A written report of the results of the test shall be signed by the party conducting the test and provided to the *code official*. Testing shall be performed at any time after creation of all penetrations of the *building thermal envelope* **have been sealed**.

- Notice: When complying with Section N1101.2.1 (R401.2.1), the building or dwelling unit shall have an air leakage rate not exceeding **3.0** air changes per hour in Climate Zones 3 through 5 when tested in accordance with Section N1102.4.1.2 (R402.4.1.2).

Testing shall be reported by the permit holder, a North Carolina licensed general contractor, a North Carolina licensed HVAC contractor, a North Carolina licensed Home Inspector, a *registered design professional*, a certified *BPI Envelope Professional* or a certified *HERS rater*.

During testing:

1. Exterior windows and doors, fireplace and stove doors shall be closed, but not sealed;
2. Dampers shall be closed, but not sealed, including exhaust, backdraft, and flue dampers;
3. Interior doors shall be open;
4. Exterior openings for continuous ventilation systems, air intake ducted to the return side of the conditioning system, and energy or heat recovery ventilators shall be closed and sealed;
5. Heating and cooling system(s) shall be turned off; and
6. Supply and return registers shall not be sealed.

The air leakage information, building air leakage result, tester name, date, and contact information, shall be included on the certificate described in Section R401.3.

The report shall be produced in the following manner: Perform a blower door test and record the *CFM50* _____. Multiply the CFM50 by 60 minutes to create CFHour50 and record _____. Then calculate the total conditioned volume of the home and record _____. Divide the CFH50 by the total volume and record the result below. If the result is less than or equal to **[3.0 ACH50]** the envelope tightness is acceptable.

Property Address: _____

Fan attachment location _____ Company Name _____

Contact Information: _____

Signature of Tester _____ Date _____

Duct testing shall be performed and reported by a certified BPI Envelope Professional, a certified HERS rater, or other certified third-party professional trained in duct leakage testing by the test equipment manufacturer.

(circle one)

APPENDIX R3C

Duct sealing, Duct air leakage test (Sections R403.3.2, Section R403.3.3)

Sample Worksheet

R403.3.2 Sealing (Mandatory). Ducts, air handlers, filter boxes, and building cavities used as ducts shall be sealed. Joints and

seams shall comply with either the *International Mechanical Code* or *International Residential Code*, as applicable.

Exception: Air impermeable spray foam products shall be permitted to be applied without additional joint seals.

R403.3.3 Duct leakage (Prescriptive) and duct testing (Mandatory). Duct testing and duct leakage shall be verified by compliance with either Section R403.3.3.1 or R403.3.3.2. Duct testing shall be verified using one of the two following methods:

R403.3.3.1 Total duct leakage. Total duct leakage less than or equal to 5 cfm (12 L/min) per 100 square feet (9.29 m²) of conditioned floor area served by that system when tested at a pressure differential of 0.1 inches w.g. (25 Pa) across the entire system, including the manufacturer's air handler enclosure.

During testing:

1. Block, if present, ventilation air duct(s) connected to the conditioning system.
2. The duct air leakage testing equipment shall be attached to the largest return in the system or to the air handler.
3. The filter shall be removed and the air handler power shall be turned off.
4. Supply boots or registers and return boxes or grilles shall be taped, plugged, or otherwise sealed air tight.
5. The hose for measuring the 25 Pascals of pressure differential shall be inserted into the boot of the supply that is nominally closest to the air handler.
6. Specific instructions from the duct testing equipment manufacturer shall be followed to reach duct test pressure and measure duct air leakage.

R403.3.3.2 Duct leakage to the outside. Conduct the test using fan pressurization of distribution system and building at a fixed reference pressure for combined supply and return leaks. Duct leakage to the outside shall be less than or equal to 4 cfm (113.3 L/min) per 100 square feet (9.29 m²) of conditioned floor area served by that system when tested at a pressure differential of 0.1 inches w.g. (25 Pa) across the entire system, relative to the outside, including the manufacturer's air handler enclosure.

During testing:

1. Block, if present, the ventilation air duct(s) connected to the conditioning system.
2. The duct air leakage testing equipment shall be attached to the largest return in the system or to the air handler.
3. The filter shall be removed and the air handler power shall be turned off.
4. Supply boots or registers and return boxes or grilles shall be taped, plugged, or otherwise sealed air tight or as tight as possible.
5. The hose for measuring the 25 Pascals of pressure differential shall be inserted into the boot of the supply that is nominally closest to the air handler.
6. Open all interconnecting doors in the building, close dampers for fireplaces and other operable dampers.
7. Set up an envelope air moving/flow regulating/flow measurement assembly, such as a blower door, following the manufacturer's prescribed procedure.
8. Specific instructions from the duct testing equipment manufacturer shall be followed to reach duct test pressure and measure duct air leakage used in combination with a blower door. Typical steps are as follows:
 - a. Depressurize the ductwork system to 25 Pa using the measurement hose in Step 5 above.
 - b. Depressurize the house to 25 Pa using an envelope air moving/flow regulating/flow measurement assembly, such as a blower door.
 - c. Correct the duct pressure to measure 0 Pa of pressure differential between the house and the ductwork system.

d. Read the cfm of duct leakage using the procedures for the specific equipment being used. (Note that most automatically calculating pressure gauges cannot compute the CFM25 automatically with a duct to house difference in pressure of 0 Pa, so the gauge setting should be set to read cfm instead of CFM25).

Testing shall be performed and reported by the permit holder, a North Carolina licensed general contractor, a North Carolina licensed HVAC contractor, a North Carolina licensed home inspector, a *registered design professional*, a certified

BPI Envelope Professional or a certified *HERS rater*. A single point depressurization, not temperature corrected, test is sufficient to comply with this provision, provided that the duct testing fan assembly(s) has been certified by the manufacturer

to be capable of conducting tests in accordance with ASTM E1554—07.

The duct leakage information, including duct leakage test selected and result, tester name, date, and contact information,

shall be included on the certificate described in Section 401.3.

For the Test Criteria, the report shall be produced in the following manner: perform the HVAC system air leakage test

and record the CFM25. Calculate the total square feet of Conditioned Floor Area (CFA) served by that system.

Multiply

CFM25 by 100, divide the result by the CFA and record the result. If the result is less than or equal to 5

CFM25/100SF for

the Total duct leakage test or less than or equal to 4 CFM25/100SF for the “Duct leakage to the outside” test, then the

HVAC system air tightness is acceptable.

Complete one duct leakage report for each HVAC system serving the home:

Property Address: _____

Test Performed: Total duct leakage or Duct leakage to the outside **(circle one)**

HVAC System Number: _____ Describe area of home served: _____

CFM25 Total _____ . Conditioned Floor Area (CFA) served by system: _____ s.f.

CFM25 x 100 divided by CFA = _____ CFM25/100SF (e.g. 100 CFM25 x 100/ 2,000 CFA = 5 CFM25/100SF)

Fan attachment location _____

Company Name _____

Contact Information: _____

Signature of Tester _____ Date _____

Permit Holder, NC Licensed General Contractor, NC Licensed HVAC Contractor, NC Licensed Home Inspector, *Registered Design Professional*, Certified *BPI Envelope Professional*, or Certified *HERS Rater*
(circle one)

APPENDIX E-3C

Duct sealing. Duct air leakage test (Sections N403.3.5, N403.3.6 (R403.3.2, Section R403.3.3)) Sample Worksheet

N1103.3.4 (R403.3.4) Sealing (Mandatory). Ducts, air handlers, filter boxes, and building cavities used as ducts shall be sealed. Joints and seams shall comply with either the *International Mechanical Code* or *International Residential Code*, as applicable.

Exception: Air-impermeable spray foam products shall be permitted to be applied without additional joint seals.

N1103.3.5 (R403.3.5) Duct testing. Ducts shall be pressure tested in accordance with ANSI/RESNET/ICC 380 or ASTM E1554 to determine air leakage by one of the following methods:

1. Rough-in test: Total leakage shall be measured with a pressure differential of 0.1 inch w.g. (25 Pa) across the system, including the manufacturer's air handler enclosure if installed at the time of the test. Registers shall be taped or otherwise sealed during the test.
2. Postconstruction test: Total leakage shall be measured with a pressure differential of 0.1 inch w.g. (25 Pa) across the entire system, including the manufacturer's air handler enclosure. Registers shall be taped or otherwise sealed during the test.

Exception: A duct air-leakage test shall not be required for ducts serving heating, cooling or ventilation systems that are not integrated with ducts serving heating or cooling systems.

N1103.3.6 (R403.3.6) Duct leakage. The total leakage of the ducts, where measured in accordance with Section R403.3.5, shall be as follows:

1. Rough-in test: The total leakage shall be less than or equal to 4.0 cubic feet per minute (113.3 L/min) per 100 square feet (9.29 m²) of conditioned floor area where the air handler is installed at the time of the test. Where the air handler is not installed at the time of the test, the total leakage shall be less than or equal to 3.0 cubic feet per minute (85 L/min) per 100 square feet (9.29 m²) of conditioned floor area.
2. Postconstruction test: Total leakage shall be less than or equal to 4.0 cubic feet per minute (113.3 L/min) per 100 square feet (9.29 m²) of conditioned floor area.
3. Test for ducts within thermal envelope: Where all ducts and air handlers are located entirely within the building thermal envelope, total leakage shall be less than or equal to 8.0 cubic feet per minute (226.6 L/min) per 100 square feet (9.29 m²) of conditioned floor area.

During testing:

1. Block, if present, ventilation air duct(s) connected to the conditioning system.
2. The duct air leakage testing equipment shall be attached to the largest return in the system or to the air handler.
3. The filter shall be removed and the air handler power shall be turned off.
4. Supply boots or registers and return boxes or grilles shall be taped, plugged, or otherwise sealed air tight.
5. The hose for measuring the 25 Pascals of pressure differential shall be inserted into the boot of the supply that is nominally closest to the air handler.
6. Specific instructions from the duct testing equipment manufacturer shall be followed to reach duct test pressure and measure duct air leakage.

Testing shall be performed and reported by the permit holder, a North Carolina licensed general contractor, a North Carolina licensed HVAC contractor, a North Carolina licensed home inspector, a registered design professional, a certified BPI Envelope Professional or a certified HERS rater. A single point depressurization, not temperature corrected, test is sufficient to comply with this provision, provided that the duct testing fan assembly(s) has been certified by the manufacturer to be capable of conducting tests in accordance with ASTM E1554—07.

The duct leakage information, including duct leakage test selected and result, tester name, date, and contact information, shall be included on the certificate described in Section 401.3.

For the Test Criteria, the report shall be produced in the following manner: perform the HVAC system air leakage test and record the CFM25. Calculate the total square feet of Conditioned Floor Area (CFA) served by that system.

- (1) Rough-in test: The total leakage shall be less than or equal to 4.0 cubic feet per minute (113.3 L/min) per 100 square feet (9.29 m²) of *conditioned floor area* where the air handler is installed at the time of the test. Where the air handler is not installed at the time of the test, the total leakage shall be less than or equal to 3.0 cubic feet per minute (85 L/min) per 100 square feet (9.29 m²) of *conditioned floor area*. Multiply CFM25 by 100, divide the result by the CFA and record the result. If the result is less than or equal to 3.0 CFM25/100SF (without airhandler, 4.0 with air handler) for the Total duct leakage test, then the HVAC system air tightness is acceptable.
- (2) Postconstruction test: Multiply CFM25 by 100, divide the result by the CFA and record the result. If the result is less than or equal to 5 CFM25/100SF for the Total duct leakage test, then the HVAC system air tightness is acceptable.
- (3) Test for ducts within thermal envelope: Where all ducts and air handlers are located entirely within the *building thermal envelope*, total leakage shall be less than or equal to 8.0 cubic feet per minute (226.6 L/min) per 100 square feet (9.29 m²) of *conditioned floor area*. Multiply CFM25 by 100, divide the result by the CFA and record the result. If the result is less than or equal to 8.0 CFM25/100SF for the Total duct leakage test, then the HVAC system air tightness is acceptable.

Complete one duct leakage report for each HVAC system serving the home:

Property Address: _____

Test Performed: (1) Rough-in test, (2) Postconstruction test, (3) Ducts within thermal envelope test **(circle one)**

HVAC System Number: _____ Describe area of home served: _____

CFM25 Total _____. Conditioned Floor Area (CFA) served by system: _____ s.f.

CFM25 x 100 divided by CFA = ____ CFM25/100SF (e.g. 100 CFM25 x 100/ 2,000 CFA = 5 CFM25/100SF)

Fan attachment location _____

Company Name _____

Contact Information: _____

Signature of Tester _____ Date _____

Duct testing shall be performed and reported by a certified BPI Envelope Professional, a certified HERS rater, or other certified third-party professional trained in duct leakage testing by the test equipment manufacturer.

(circle one)

APPENDIX R4

**ADDITIONAL VOLUNTARY CRITERIA
FOR INCREASING ENERGY EFFICIENCY
(High-Efficiency Residential Option)**

Table R4C

Not used

Sample Confirmation Form for ADDITIONAL VOLUNTARY CRITERIA FOR INCREASING ENERGY EFFICIENCY
(High-Efficiency Residential Option)

Not Used

R4D:
SAMPLE WORKSHEETS FOR RESIDENTIAL AIR AND DUCT LEAKAGE TESTING

R4D.1

Air sealing: Testing (Section R402.4.2.2)

Sample Worksheet for Alternative Residential Energy Code for Higher Efficiency

Air sealing. Building envelope air tightness shall be demonstrated by Section R402.4.2.2:

Air sealing: Testing (Section R402.4.2.2)

Sample Worksheet for Alternative Residential Energy Code for Higher Efficiency

Not used in 2024 Proposed Code

