

State of North Carolina Regulations for Manufactured Homes



2019 Edition

**North Carolina Manufactured Housing Board
and
North Carolina Department of Insurance
Office of State Fire Marshal
Manufactured Building Division
1202 Mail Service Center
Raleigh, North Carolina 27669-1202**

State of North Carolina

Regulations for

Manufactured Homes

2019 Edition

*Second Printing: February 2023
(Errata through October 2022)*

Effective: September 1, 2019

This Standard for the Installation of Manufactured Homes is hereby adopted by the Commissioner of Insurance in accordance with the Act of the North Carolina General Assembly of 1969, Chapter 961.

Mike Causey
Commissioner of Insurance
State Fire Marshal

Joseph H. Sadler, Jr., P.E.
Deputy Commissioner
Manufactured Building Division

FOREWORD

North Carolina has been a pioneer in the field of regulations to protect its citizens from unsafe buildings, with a statewide building code in force since 1936. This building code provided local inspectors with clear guidelines for insuring that buildings constructed in their jurisdictions were safe with regard to building, plumbing, mechanical, and electrical systems. However, the building code was primarily directed to site built structures. The modern manufactured home is a factory built unit that is marketed as a finished product, making it difficult or impractical for a local building official to inspect the structure for code compliance.

In 1969, the North Carolina General Assembly enacted a law requiring all mobile homes that were manufactured, sold, or offered for sale in North Carolina after July 1, 1970 to be manufactured in accordance with a model code, *Standard for Mobile Homes USAS A119.1*. This 1969 legislation also preempted the local inspection of mobile homes provided that homes were evaluated, tested and inspected by Underwriters' Laboratories or a similar agency approved by the North Carolina State Building Code Council. Many manufacturers chose the factory inspection method which utilized affixed labels as proof of compliance with the *Standard for Mobile Homes USAS A119.1*. However, some manufacturers chose to rely on the availability and willingness of local inspectors to accept unlabeled mobile homes. Others simply elected to take the chance that there would be no local inspection of these homes in many areas of North Carolina.

In 1971, the General Assembly revised the 1969 legislation. This revision made it mandatory that all mobile homes manufactured to be sold in North Carolina after September 1, 1971 have a *Standard for Mobile Homes USAS A119.1* "Label of Compliance" affixed by an independent, competent, solvent and trustworthy organization approved and licensed by the North Carolina State Building Code Council. In 1974, the United States Congress determined that, in order "to reduce the number of personal injuries and deaths and the amount of insurance cost and property damage resulting from manufactured/mobile home accidents and to improve the quality and durability of manufactured/mobile homes", it would be necessary to establish federal construction and safety standards. These standards were implemented through the Department of Housing and Urban Development (HUD) effective June 15, 1976, and are entitled *Part 3280, Manufactured Home Construction and Safety Standards*. These standards preempted state jurisdiction over the construction of all manufactured/mobile homes after June 15, 1976. The Commissioner of Insurance retained jurisdiction over the *installation* of homes throughout the State and has promulgated this edition of the *State of North Carolina Regulations for Manufactured Homes* (hereafter called "this Code") and previous editions.

Effective August 11, 1982, the HUD officially changed the name "mobile home" to "manufactured home". The State of North Carolina also adopted this name change on June 27, 1985. It should be noted that the name change did not affect the federal construction standards in any way.

Prior to July 13, 1994, North Carolina was divided into two Wind Zones for the construction and installation of manufactured homes: Zone I (standard) and Zone II (hurricane resistive). Effective July 13, 1994, the federal *Manufactured Home Construction and Safety Standards* required North Carolina to be divided in three Wind Zones: Zone I (standard), Zone II (100 mph), and Zone III (110 mph). All homes with a date of manufacture on or after July 13, 1994 are subject to the requirements for these new Wind Zones.

The current General Statutes that apply to manufactured homes are included as **Appendix J** of this Code. Current APA Rules applicable to manufactured homes are included in **Appendix K** of this Code.

Effective January 1, 2009, HUD required the new **Part 3285, Model Manufactured Home Installation Standards**, to be used for the installation of all **NEW** manufactured homes nationwide. All licensed HUD manufacturers were required, not later than January 1, 2009, to update their installation manuals for all **NEW** homes to comply with **Part 3285, Model Manufactured Home Installation Standards**.

States such as North Carolina, which elect to operate an installation program for manufactured homes in lieu of the federal program, must implement installation standards that provide protection for consumers that is equal to or exceeds that provided by the **Part 3285 Standards**. The *State of North Carolina Regulations for Manufactured Homes, 2019 Edition*, which applies to **USED** homes, has been rewritten to incorporate the standards that will meet or exceed the requirements of **Part 3285**. Accordingly, **NEW and USED** manufactured homes in North Carolina may be set up using the installation manual which came with the home, if available, or by using the generic installation standards provided in the *State of North Carolina Regulations for Manufactured Homes, 2019 Edition*. Copies of the current edition of the *State of North Carolina Regulations for Manufactured Homes* can be found at this link: <https://www.ncosfm.gov/manufactured-bldg/manufactured-homes>

It is hoped that this Code will provide a better understanding of the requirements for manufactured home installations in North Carolina for both consumers and local officials, and that the result will be improved protection of the public health and safety of citizens of North Carolina who purchase manufactured homes.

MANUFACTURED HOME REGULATIONS

TABLE OF CONTENTS

| | |
|--|-----------|
| INTRODUCTION and GENERAL INFORMATION | 6 |
| CHAPTER 1 ADMINISTRATION | 8 |
| 1.1 TITLE | 8 |
| 1.2 GENERAL PROVISIONS | 8 |
| 1.2.1 Purpose | 8 |
| 1.2.2 Quality Control | 8 |
| 1.2.3 Permits | 8 |
| 1.2.4 License Holder to Obtain Permit | 8 |
| 1.2.5 Location of Home on Site | 8 |
| 1.3 SCOPE | 8 |
| 1.3.1 Applicability | 8 |
| 1.3.2 Authority | 9 |
| 1.3.3 Enforcement with Local Officials | 9 |
| 1.3.4 Repairs and Alterations | 9 |
| 1.3.5 Appendices | 9 |
| 1.3.6 Referenced Standards | 9 |
| 1.3.7 Suggested Guidelines for Acceptance of Pre-HUD Manufactured Homes | 9 |
| 1.3.8 Requirements for Dealer Lot Set-Ups | 9 |
| 1.3.9 HUD Labeled USED Homes that are Damaged or Deficient | 9 |
| CHAPTER 2 DEFINITIONS | 10 |
| CHAPTER 3 REGULATIONS FOR THE INSTALLATION OF MANUFACTURED HOMES | 15 |
| 3.1 PERSONS AUTHORIZED TO SET UP MANUFACTURED HOMES | 15 |
| 3.2 UTILITY CONNECTIONS | 15 |
| 3.3 SITE PREPARATION | 15 |
| 3.3.1 Suitability of Site | 15 |
| 3.3.2 Removal of Debris | 15 |
| 3.3.3 Vegetation and Organic Material | 15 |
| 3.3.4 Proper Drainage | 15 |
| 3.3.5 Fire Separation | 16 |
| 3.3.6 Siting of Home – Setup Contractor Responsibility | 16 |
| 3.4 WIND and THERMAL (U/O VALUE) ZONES | 17 |
| 3.4.1 Current Wind Zones | 17 |
| 3.4.2 Homes Manufactured on or after July 13, 1994 | 17 |
| 3.4.3 Homes Located within 1500 feet of the Coastline | 17 |
| 3.4.4 No Home Located in Higher Wind Zone than that Indicated on Data Plate | 17 |
| 3.4.5 Home Located in Lower Wind Zone than that Indicated on Data Plate | 18 |

TABLE OF CONTENTS (cont'd.)

| | | |
|------------|---|-----------|
| 3.4.6 | Homes Manufactured before July 13, 1994 | 18 |
| 3.4.7 | Thermal (U/O Value) Zones | 18 |
| 3.5 | FOOTINGS | 18 |
| 3.5.1 | Load Bearing Capacity of Footings | 18 |
| 3.5.2 | Bottom of Footings | 18 |
| 3.5.3 | Soil Bearing Capacity | 19 |
| | Table 3.5.2 Minimum Footing Depth | 20 |
| 3.5.4 | Footing Materials | 20 |
| 3.5.5 | Footing Size | 21 |
| 3.5.6 | Footing Orientation | 21 |
| 3.5.7 | Concrete Slabs or Continuous Footings | 21 |
| 3.6 | SKIRTING | 21 |
| 3.6.1 | Skirting -- General Requirements | 21 |
| 3.6.2 | Skirting Material | 21 |
| 3.6.3 | Masonry Curtain Walls Not More Than 40 Inches in Height | 21 |
| 3.6.4 | Masonry Curtain Walls More Than 40 Inches in Height | 22 |
| 3.6.5 | Ventilation | 23 |
| 3.6.6 | Crawl Space Access | 23 |
| 3.7 | PIERS and PIER SPACING | 24 |
| 3.7.1 | Pier Design and Spacing -- General | 24 |
| 3.7.2 | Minimum Pier Height and Ground Clearance | 24 |
| 3.7.3 | Pier Materials | 24 |
| 3.7.4 | Single Stacked Piers | 24 |
| 3.7.5 | Double Stacked Piers | 26 |
| 3.7.6 | Piers Designed by Professional Engineer or Architect | 28 |
| 3.7.7 | Elevated Manufactured Homes | 28 |
| 3.7.8 | Piers Double Stacked at Discretion of Installer | 29 |
| 3.7.9 | Leveling of Manufactured Homes | 29 |
| | Table 3.7 Main I-Beam Pier Spacing | 30 |
| 3.7.10 | Procedure for Determining Footing Size for Marriage Line and Perimeter Piers | 32 |
| 3.7.11 | Marriage Line and Perimeter Piers – Interference with Outriggers | 35 |
| 3.7.12 | Marriage Line Piers -- Allowable Offset | 35 |
| 3.8 | MULTI-SECTION CONNECTIONS | 35 |
| 3.8.1 | Multi-Section Homes -- General Provisions | 35 |
| 3.8.2 | Preparation for Marriage Line Connections | 35 |
| 3.8.3 | Prescriptive Marriage Line Connections for Manufactured Homes | 35 |
| 3.8.4 | Roofing Application | 44 |
| 3.8.5 | Exterior Wall Coverings | 45 |
| 3.8.6 | Hinged Roofs and Eaves | 45 |
| 3.8.7 | HUD Section §3282.14 Alternative Construction Procedures | 45 |
| 3.8.8 | HUD Section §3282.600 On-Site Completion of Construction (SC) | 46 |
| 3.8.9 | Garden and Bay Windows | 46 |
| 3.8.10. | Bottom Board Repair | 46 |
| 3.9 | ANCHORING SYSTEMS | 47 |
| 3.9.1 | Anchoring Systems -- General Requirements | 47 |
| 3.9.2 | Certification and Capacity of Anchoring Equipment | 47 |
| 3.9.3 | Resistance to Weather Deterioration | 47 |
| 3.9.4 | Tie Strapping Material | 47 |

TABLE OF CONTENTS (cont'd.)

| | | |
|-------------|---|-----------|
| 3.9.5 | Ground Anchors _____ | 47 |
| | Table 3.9.5 Soil Classification Chart _____ | 48 |
| 3.9.6 | Anchoring System Installation _____ | 48 |
| 3.9.7 | Maintaining Anchoring Systems _____ | 51 |
| 3.9.8 | Permanency of Connections _____ | 51 |
| 3.9.9 | Special Ties _____ | 51 |
| 3.9.10 | Alternate Anchoring Methods _____ | 51 |
| | Table 3.9.6 Diagonal Tie Strap Spacing _____ | 52 |
| 3.10 | CRAWLSPACE ENCLOSURES _____ | 57 |
| 3.10.1 | Ventilation of Skirted Homes _____ | 57 |
| 3.10.2 | Means of Providing Ventilation _____ | 57 |
| 3.10.3 | Required Vapor Barrier _____ | 57 |
| 3.10.4 | Required Ventilation Opening Area _____ | 57 |
| | Table 3.10.4 Crawlspace Ventilation _____ | 58 |
| 3.10.5 | Termination of Exhaust Air Vents and Condensate Drains _____ | 59 |
| 3.10.6 | Source of Intake or Combustion Air _____ | 60 |
| 3.11 | EGRESS REQUIREMENTS _____ | 60 |
| 3.11.1 | Egress - General Requirements _____ | 60 |
| 3.11.2 | Exterior Steps and Stairways _____ | 60 |
| 3.11.3 | Ramps _____ | 63 |
| 3.11.4 | Landings _____ | 63 |
| 3.11.5 | Fasteners _____ | 63 |
| 3.11.6 | Auxiliary Structures _____ | 63 |
| 3.12 | ELECTRICAL REQUIREMENTS _____ | 64 |
| 3.12.1 | Electrical Requirements – General _____ | 64 |
| 3.12.1.1 | Bonding _____ | 64 |
| 3.12.2 | Electrical Inspection Guidelines for Manufactured Homes _____ | 64 |
| 3.12.3 | Miscellaneous Lights and Fixtures _____ | 64 |
| 3.12.4 | Electrical Testing _____ | 65 |
| 3.12.5 | Telephone and Cable TV _____ | 66 |
| 3.13 | PLUMBING REQUIREMENTS _____ | 66 |
| 3.13.1 | Site Installed Plumbing – Administration _____ | 66 |
| 3.13.2 | Plumbing Definitions _____ | 67 |
| 3.13.3 | General Regulations _____ | 68 |
| 3.13.4 | Water Supply and Distribution _____ | 72 |
| 3.13.5 | Materials, Joints and Connections _____ | 72 |
| 3.13.6 | Requirements for Water Supply and Distribution System _____ | 75 |
| 3.13.7 | Sanitary Drainage _____ | 76 |
| 3.14 | MECHANICAL REQUIREMENTS _____ | 81 |
| 3.14.1 | Mechanical Requirements – General _____ | 81 |
| 3.14.2 | Fuel Gas Systems _____ | 81 |
| 3.14.3 | Unvented Gas-Fired Heaters in Manufactured Homes _____ | 82 |
| 3.14.4 | Prefabricated Fireplace Units in Manufactured Homes _____ | 82 |
| 3.14.5 | Prefabricated Fireplace Units with Gas Logs _____ | 83 |
| 3.14.6 | Oil Piping Systems _____ | 83 |
| 3.14.7 | Comfort Cooling Systems _____ | 84 |
| 3.14.8 | Clothes Dryer Exhaust _____ | 84 |
| 3.14.9 | Crossover Air-Handling Ducts _____ | 85 |

TABLE OF CONTENTS (cont'd.)

| | | |
|-------------------|--|------------|
| 3.15 | MANUFACTURED HOMES LOCATED IN FLOOD HAZARD AREAS | 86 |
| 3.15.1 | General | 86 |
| 3.15.2 | Definitions | 86 |
| 3.15.3 | Establishment of Flood Hazard Areas | 88 |
| 3.15.4 | Elevation Requirements | 88 |
| 3.15.5 | Foundation Design and Construction | 88 |
| 3.15.6 | Flood Hazard Certificates | 88 |
| 3.15.7 | Resistance to Weather Deterioration | 89 |
| 3.15.8 | Corrosion Resistance Requirements in Coastal and Ocean High Hazard Areas | 89 |
| 3.15.9 | Protection of Mechanical, Plumbing, and Electrical Systems | 90 |
| APPENDIX A | Elevated / Flood Hazard Foundation Design | 91 |
| APPENDIX B | Conversion of Manufactured Home to an Occupancy other than Single Family Dwelling | 97 |
| APPENDIX C | Repair of Damaged Homes, Refurbished Homes, and Homes Sold for Salvage | 98 |
| APPENDIX D | Recreational Park Trailers | 103 |
| APPENDIX E | Suggested Guidelines for Acceptance of Pre-HUD Manufactured Homes | 105 |
| APPENDIX F | Requirements for Dealer Lot Set-ups | 108 |
| APPENDIX G | Safety Guidelines for Manufactured Home Installations | 109 |
| APPENDIX H | Suggested Checklist for Use by Local Inspectors | 110 |
| APPENDIX I | Factory Built Home Identification | 111 |
| APPENDIX J | General Statutes -- Articles 9A, 9B, 9C and Excerpts | 123 |
| APPENDIX K | APA Rules | 138 |
| APPENDIX L | State Plan | 154 |

INTRODUCTION and GENERAL INFORMATION

INTENDED USAGE OF MANUFACTURED HOMES COVERED UNDER THIS CODE. The Provisions of this Code are intended to apply to manufactured homes (single-section, multi-section, or expandable types) for use as single family dwellings.

Note 1: The Federal Manufactured Home Construction and Safety Standards (MHCSS) cover one family occupancies only. This standard makes no provisions for other residential occupancies.

Note 2: This Code does not apply to manufactured homes used for other than dwelling purposes. **See Appendix B for Conversion of a Manufactured Home to an Occupancy Other Than A Single Family Dwelling.**

Note 3: The provisions of this Code shall not apply to recreational vehicles as defined in the **NFPA 1192, Standard on Recreational Vehicles**, current Edition, or to Park Trailers as defined in the **ANSI A119.5, Recreational Park Trailer Standard, current Edition**. See **Appendix D, Recreational Park Trailers**.

Note 4: With reference to Section 103.1.10 *Administration and Enforcement Requirements Code*, current edition, NC State Building Code, a manufactured home may be used as a storage building on a farm that is located outside the building regulation jurisdiction of any municipality, provided that any electrical wiring of the unit is verified by the applicable county building jurisdiction to be in accordance with the requirements of the *NC Electrical Code*, current edition, NC State Building Code.

TYPES OF STRUCTURE COVERED.

Manufactured Homes. The manufactured homes covered under this Code are:

1) manufactured homes complying with the U.S. Department of Housing and Urban Development *Manufactured Home Construction and Safety Standards Program* as set forth in U.S. 24 C.F.R., Parts as listed below and

2) manufactured homes built prior to June 15, 1976, including those complying with the *Standard for Mobile Homes NFPA 501B/ANSI A119.1* (edition in effect at the time of manufacture).

Note: The HUD *Manufactured Home Construction and Safety Standards Program* is composed of the following parts as authorized by 42.U.S.C.5401 et seq.:

*Part 3280 – Manufactured Home Construction and Safety Standards

*Part 3282 – Manufactured Home Procedural and Enforcement Regulations

*Part 3285 – Model Manufactured Home Installation Standards

*Part 3286 – Manufactured Housing Installation Rules and Regulations

*Part 3288 – Manufactured Home Dispute Resolution Program

Hereafter, “manufactured home” will be used interchangeably with “home”.

USE OF THIS CODE. This Code contains instructions, including specifications and procedures, for the installation and connection of a manufactured home. It has been written in an objective and straightforward manner so as to be understandable by persons without extensive technical training. It includes tables and figures giving important data for proper installation. Careful adherence to this Code by the homeowner and installer is essential, and consultation with a professional engineer or architect will be required if unusual circumstances occur that are not covered in the text. This will help assure the homeowner of a quality, safe and affordable home for many years to come.

PRE-INSTALLATION CONSIDERATIONS. Prior to locating or relocating a manufactured home, it will be necessary to contact the authority having jurisdiction regarding permitting procedures. Local jurisdictions will likely require permits to be obtained prior to the beginning any part of the installation. Inspections will be required in conjunction with permits to help assure a correct and safe installation of the manufactured home. Notification of the jurisdiction at various stages of the installation may be required. *The local jurisdiction shall be contacted as to the number and type of inspections that will be required.* Local zoning or development covenants may apply that should also be taken into consideration.

ALTERATIONS. Alterations of a home consist of activities such as modification of the electrical, plumbing, or HVAC systems, the addition of a room, carport or garage, or major repairs such as a new roof. The authority having jurisdiction must be contacted prior to beginning such work. Applicable permits will be required.

SAFETY. Installers should, at a minimum, follow the safety instructions provided **Appendix G, Safety Guidelines for Manufactured Home Installations**.

TRANSPORTATION DAMAGE. A new manufactured home that is damaged in transit so that it no longer conforms to the *Manufactured Home Construction and Safety Standards* shall not be accepted by local building officials until proper repairs are made. Manufactured home dealers are prohibited from selling, leasing, or offering for sale or lease any new manufactured home that does not conform to the applicable standards.

CONSUMER AND INSTALLATION MANUALS. Manufacturers of HUD-labeled homes are required by the federal regulations to provide each new home with *Consumer* and *Installation* manuals. The *Consumer* manual provides guidelines concerning the operation, maintenance, and repair of the manufactured home. The *Installation* manual describes the foundation and anchorage system designed for the home and provides detailed instructions for installation at the site. Authorized inspection personnel as well as installers shall ensure that consumer and installation manuals are available from the homeowner at the time of installation and inspection.

CONSUMER INFORMATION CARD. The dealer of a manufactured home shall fill out the CONSUMER INFORMATION CARD in accordance with Part 3282, *Manufactured Home Procedural and Enforcement Regulations*, Section §3282.255, and return it to the manufacturer. This will allow the homeowner to be readily notified if necessary.

CONSUMER ASSISTANCE. This edition of the *State of North Carolina Regulations For Manufactured Homes* is offered for the purpose of insuring the safe and efficient installation of manufactured homes throughout the State. The North Carolina General Assembly, in N.C.G.S. § 143-143.8, states that “it is reasonable and proper for the manufactured home industry to cooperate with the Commissioner of Insurance, through the establishment of the North Carolina Manufactured Housing Board, to provide for a comprehensive framework for industry regulations”. In its role as staff to the Board, the Manufactured Building Division has prepared these regulations and has made every effort to clarify potential ambiguities. Personnel of the Division are available on a daily basis to answer any questions that may arise and are available by phone or fax at:

Phone 919-647-0000
Fax 919-715-0067

Consumer Assistance Line
1-800-587-2716

Chapter 1 -- ADMINISTRATION

1.1 TITLE

Provisions in the following sections shall constitute and be known and may be cited as “The State of North Carolina Regulations for Manufactured Homes”, hereinafter referred to as “this Code”.

1.2 GENERAL PROVISIONS

1.2.1 Purpose

This Code is hereby construed to secure public safety, health and general welfare through protection of the quality, durability, and safety of manufactured home installations. Such interests and purposes are accomplished through structural integrity, stability, sanitation, and safety to life and property from fire and other hazards incidental to the installation, alteration, repair, removal, demolition, use and occupancy of manufactured homes.

1.2.2 Quality Control

Quality control of materials and workmanship is not within the purview of this Code except as it relates to the purposes stated herein. Federal Standards require workmanship reflecting journeyman quality of work for the various trades.

1.2.3 Permits

A person, firm or corporation shall not install, construct, enlarge, alter, repair, locate, improve, convert or demolish any manufactured home in the applicable jurisdiction, or cause the same to be done, without first obtaining a building permit from the Building Official. Note that per the **NC General Statutes**, a violation of the above shall constitute a Class 1 misdemeanor.

Exception: Warranty repairs do not require a permit.

1.2.4 License Holder to Obtain Permit

The set-up contractor who is installing a particular *home shall be the party who obtains required permits from the local jurisdiction*, and the name under which the set-up contractor is licensed, and the license number, shall appear on the permit.

EXCEPTION: The homeowner may obtain the permit on behalf of the installer so long as the name under which the set-up contractor is licensed, and the license number, appear on the permit. **NOTE:** This exception does not relieve the set-up contractor of the responsibility of insuring that permits are obtained prior to beginning any work pertaining to the set up. Regardless of which party obtains the permit, the setup contractor shall not move the home to the site until he or she has the permit in hand.

If a homeowner is acting as his or her own contractor and hires another party to perform the work, this party must be a licensed set-up contractor and this set-up contractor shall obtain the permit except as provided above. In all cases the license name and number of the set-up contractor shall appear on the permit.

1.2.5 Location of Home on Site

The homeowner may indicate the particular location where the home is to be placed on the site. However, *it is the responsibility of the licensed dealer or set-up contractor who is installing the home* to ensure that all local setback requirements are met and that the home as located on site does not encroach upon any right of way, septic system, or other such restrictions.

1.3 SCOPE

1.3.1 Applicability

The provisions of this Code shall apply to the installation, alteration, repair, use and occupancy of every manufactured home and the installation thereof. All appurtenances (i.e. field equipment, etc.) connected or attached to such manufactured homes shall comply with the *North Carolina Residential Code*, current edition and the *North Carolina Electrical Code*, current edition. All NEW homes shall be installed in accordance with the Manufacturer’s Installation Instructions, which are required to comply with the HUD document, *24 CFR Part 3285, Model Manufactured Home Installation Standards*. All USED manufactured homes **with a date of manufacture prior to January 1, 2009** shall be installed in accordance with the provisions of this Code. This Edition has been updated to meet or exceed the requirements of *24 CFR Part 3285, Model Manufactured Home Installation Standards*. All USED manufactured homes **with a date of manufacture on or after January 1, 2009** shall be installed in accordance with the Manufacturer’s Installation Instructions, if available, OR the provisions of this Code. For ALL homes that are installed using the Manufacturer’s Installation Instructions, any applicable areas not covered in the Manufacturer’s Installation Instructions shall be in accordance with this Code.

NOTE: IN ALL CASES WHERE ELECTRICAL CONNECTIONS OR EQUIPMENT ARE FIELD INSTALLED CONTACT THE LOCAL AUTHORITY HAVING JURISDICTION (LAHJ).

1.3.2 Authority

North Carolina General Statute § 143-143.15 vests the authority for the adoption of this Code with the Commissioner of Insurance, and requires that the set-up of manufactured homes be in accordance with the provisions of the Code. The statewide elected Commissioner of Insurance, responsible directly to the people of North Carolina, adopts the standards for manufactured/mobile homes and the installation thereof. The Federal Manufactured Home Construction and Safety Standards, as provided for under the National Manufactured Housing Construction and Safety Standards Act of 1974, was adopted as the standards for the construction of manufactured homes, effective June 15, 1976. Part 4, MOBILE HOME LOT FACILITIES OF ANSI A119.3, (Entitled “STANDARD FOR MOBILE HOMES INCLUDING MOBILE HOME PARK REQUIREMENTS”), was adopted as amended as the standard for the installation of manufactured/mobile homes, effective June 15, 1976 through June 30, 1995. The *State of North Carolina Regulations for Manufactured/Mobile Homes*, 1995 edition, became effective July 1, 1995, with 1996 revisions effective January 1, 1997. The *State of North Carolina Regulations for Manufactured Homes, 2004 Edition*, became effective March 1, 2004, with 2004 Revisions effective September 1, 2004. This Edition remained in force until the effective date of the present Code.

1.3.3 Enforcement With Local Officials

The Commissioner of Insurance administers the enforcement of the Code through the Manufactured Building Division. The enforcement of this Code by all local inspection jurisdictions throughout the State is *mandatory*. While this Code is not intended to circumvent any local ordinances concerning zoning, land use, etc., the technical provisions of this Code shall not be made more stringent by any local jurisdiction without the written consent of the Commissioner of Insurance or his designee. A suggested checklist for use by local inspectors is given in **Appendix H**.

1.3.4 Repairs & Alterations

The *State Plan* (see **Appendix L**) requires that repairs or alterations to **USED** manufactured homes be inspected by an independent third party inspection agency approved by HUD and that a certification be issued that repairs have been properly made. However, repairs and alterations may be inspected and approved by local officials. Minor repairs and alterations that are inspected and approved by local officials shall comply with the applicable requirements of the *North Carolina Residential Code* (current edition), or shall be of materials and workmanship that equal to or better than that of the original construction of the home. All electrical repairs, alterations, and additions that are inspected and approved by the local officials shall comply with the *North Carolina Electrical Code*, current edition. A certification shall be issued indicating that the repairs have been properly made. As an alternate to local inspection, such repairs and alterations may be certified by a North Carolina registered engineer or architect. The certification shall be in the form of a *sealed* document which states that the engineer, architect or his or her representative has personally inspected the home and confirmed that all repairs comply with applicable Sections of the *North Carolina Residential Code* and the *North Carolina Electrical Code*, current editions. For specific procedures regarding the repair of damaged homes and homes sold for salvage, see **Appendix C**. The Data Plate (if present) and the HUD label (if present) shall not be removed from the home in the course of making repairs. Repairs or alterations of **NEW** homes cannot take the home out of compliance with the regulations in 24 CFR Part 3280 or Part 3282.

1.3.5 Appendices

Appendices specifically referenced in the text of this Code shall be considered incorporated by reference and enforceable.

1.3.6 Referenced Standards

Standards referenced in this Code shall be considered an integral part of this Code without separate adoption. If specific portions of a standard are denoted by Code text, only those cited portions of the standard shall be enforced. Where Code provisions conflict with a standard, the Code provisions shall be enforced. Permissive and advisory provisions in a standard shall not be construed as mandatory.

1.3.7 Suggested Guidelines for Acceptance of Pre-HUD Manufactured Homes

Suggested guidelines for use by local inspection jurisdictions in accepting pre-HUD homes (date of manufacture prior to June 15, 1976) are given in **Appendix E**.

1.3.8 Requirements for Dealer Lot Set-ups

NEW homes manufactured on or after January 1, 2009 shall be set up on dealer lots in accordance with the manufacturer's installation manual. USED homes shall be set up on dealer lots in accordance with **Appendix F**.

1.3.9 HUD Labeled USED Homes that are Damaged or Deficient

The presence of a HUD label on a USED home indicates that the home was originally constructed in compliance with the Federal standard, *Part 3280, Manufactured Home Construction and Safety Standards*. If such a home is found to be damaged or deficient, then repairs can be made as described in **Section 1.3.4 - Repairs and Alterations, Appendix C - REPAIR OF DAMAGED HOMES, REFURBISHED HOMES, AND HOMES SOLD FOR SALVAGE**, and may be required to comply with minimum housing or other ordinances applicable to the local jurisdiction.

Chapter 2 -- DEFINITIONS

ACCESSORY BUILDING OR STRUCTURE — A building or structure which is an addition to or supplements the facilities provided by a manufactured home. All such buildings or structures not provided or approved by the home manufacturer shall be entirely self-supporting unless designed and approved by a North Carolina registered engineer or architect, and shall be constructed in accordance with the *North Carolina Residential Code* (current edition). Also known as AUXILIARY STRUCTURES. Examples are: awnings, garages, storage structures, carports, fences, windbreaks, or porches.

ANCHORING EQUIPMENT — Ties, straps, cables, turnbuckles, chains, and other approved components, including tensioning devices that are used to secure a manufactured home to anchor assembly.

ANCHORING SYSTEM --- A combination of anchoring equipment and anchor assemblies that will, when properly designed and installed, resist the uplift, overturning, and lateral forces on the manufactured home and on its support and foundation system.

APPROVED — Acceptable to the authority having jurisdiction.

AUTHORITY HAVING JURISDICTION — The organization, office, or individual responsible for approving plans, equipment, installations, or alteration procedures.

AWNING — A shade structure supported by posts or columns and entirely or partially supported by a manufactured home.

BALING — A method of “wrapping” a cross section (roof, walls, and floor) and the main frame (chassis) of a manufactured home.

BASE FLOOD --- The flood having a one percent chance of being equaled or exceeded in any given year.

BASE FLOOD ELEVATION (BFE) --- The elevation of the base flood, including wave height, relative to the datum specified on a Local Authority Having Jurisdiction’s flood hazard map.

CABANA — A room enclosure erected or constructed adjacent to a manufactured home for residential use by the occupant of the manufactured home.

CAP BLOCK (PIER) – The block of solid concrete masonry or other approved material immediately above the uppermost 8” concrete masonry unit in a pier. All material above the cap block is considered “filler”.

CARPORT — An awning or shade structure for a vehicle or vehicles that may be freestanding or partially supported by a manufactured home.

COASTLINE --- For the purposes of this Code, “coastline” is defined as land directly adjacent to the Atlantic Ocean, directly adjacent to all Sounds, whether mainland or island shores, and directly adjacent to the Intracoastal Waterway, whether mainland or island shores.

COMFORT COOLING CERTIFICATE --- A certificate permanently affixed to an interior surface of new homes specifying the factory design and preparations for air conditioning the manufactured home.

CONSTRUCTION ALTERATION — The replacement, addition, modification, or removal of any equipment or installation which may affect the originally approved design of construction, plumbing, heating, cooling, fuel-burning or electrical systems.

CONTROLLED FILL --- Fill that has been compacted to at least 90% of maximum relative density with a minimum load bearing capacity of 2000 psf, verified by a local soil testing agency or professional engineer. Controlled fill shall be placed and compacted in layers, and shall be free of grass or organic materials.

CROSSOVERS --- Utility interconnections in multi-section homes that are located where the sections are joined. Crossover connections include heating and cooling ducts, electrical circuits, water pipes, drain plumbing, and gas lines.

DAPIA (DESIGN APPROVAL PIA) --- See Primary Inspection Agency (PIA)

DECK — An exterior floor system supported on at least two opposing sides by an adjoining structure and/or posts, piers, or other independent supports, that is greater than 36 square feet in area and is constructed in accordance with the *North Carolina Residential Code, current edition*.

DEFECT --- Failure to comply with an applicable Federal manufactured home safety and construction standard that renders the manufactured home or any part or component thereof not fit for the ordinary use for which it was intended, but does not result in an unreasonable risk of injury or death to occupants of the affected manufactured home. (See IMMEDIATE SAFETY HAZARD, NONCOMPLIANCE, and SERIOUS DEFECT)

DESIGN APPROVAL PRIMARY INSPECTION AGENCY (DAPIA) --- A state or private organization that has been accepted by the Secretary in accordance with the requirements of Part 3282, Subpart H, which evaluates and approves or disapproves manufactured home designs and quality control procedures.

DIAGONAL TIE — A tie intended to resist horizontal or shear forces, but which may resist vertical, uplift, and overturning forces.

DWELLING UNIT — One or more habitable rooms which are designed to be occupied by one family, with facilities for living, sleeping, cooking, eating, and sanitation.

FEEDER ASSEMBLY — The overhead or under-chassis feeder conductors, including the grounding conductor, together with necessary fittings and equipment, or a power supply cord listed for manufactured home use, designed for the purpose of delivering energy from the source of electrical supply to the distribution panelboard within the manufactured home.

FLOOD HAZARD AREA --- The greater of either: The special flood hazard area shown on the flood insurance rate map; or the area subject to flooding during the design flood and shown on a Local Authority Having Jurisdiction's flood hazard map, or otherwise legally designated.

FLOOD HAZARD MAP --- A map delineating the flood hazard area and adopted by a Local Authority Having Jurisdiction.

FOOTING — That portion of the support system that transmits loads directly to the soil.

FRAME --- The fabricated rigid substructure which provides considerable support to the affixed manufactured home structure both during transport and on site, and also provides a platform for securement of the running gear assembly, the drawbar and coupling mechanism.

FOUNDATION SYSTEM — A system of support that is capable of transferring all design loads to the ground, including elements of the support system, as defined in this section, or a site-built permanent foundation that meets the requirements of 24 CFR 3282.12.

GARAGE — A structure located on a manufactured home site and designed for the storage of motor vehicles.

GAS SUPPLY CONNECTOR, MANUFACTURED HOME — A listed connector designed for connecting the manufactured home to the gas supply source.

GROUND ANCHOR — A specific anchoring assembly device designed to transfer home anchoring loads to the ground.

HABITABLE ROOM — A room or enclosed floor space arranged for living, eating, food preparation, or sleeping purposes, not including bathrooms, toilet compartments, laundries, pantries, foyers, hallways, or other accessory spaces.

IMMEDIATE SAFETY HAZARD --- A hazard that presents an imminent and unreasonable risk of death or severe personal injury that may or may not be related to failure to comply with an applicable Federal manufactured home construction or safety standard. (See DEFECT, NONCOMPLIANCE, and SERIOUS DEFECT)

INSTALLATION — Assembly, at the site of occupancy, of all portions of the manufactured home, connection of the home to existing utility connections, and installation of support or anchoring systems.

INSTALLATION ALTERATION — The replacement, addition, modification, or removal of any components of the required ground support or ground anchoring systems for a manufactured home.

INSTALLATION INSTRUCTIONS --- DAPIA-approved instructions provided by the home manufacturer that accompany each new manufactured home and detail the home manufacturer requirements for support and anchoring systems, and other work completed at the installation site to comply with the Model Installation Standards and the Manufactured Home Construction and Safety Standards in 24 CFR Part 3280.

INSTALLATION STANDARDS --- Reasonable specifications for the installation of a new manufactured home, at the place of occupancy, to ensure proper siting; the joining of all sections of the home; and the installation of stabilization, support, or anchoring systems.

INSTALLER --- A licensed set-up contractor, or a homeowner setting up his or her own home.

IPIA (PRODUCTION INSPECTION PIA) --- See Primary Inspection Agency (PIA)

LABELED — A label, symbol, or other identifying mark of a nationally recognized testing laboratory, inspection agency, or other organization concerned with product evaluation that maintains periodic inspection of production of labeled equipment or materials, and by whose labeling is indicated compliance with nationally recognized standards or tests to determine suitable usage in a specified manner.

LANDING — A platform at the top or bottom of manufactured home steps that is thirty-six (36) square feet or less in area and is constructed in accordance with this Code.

LENGTH OF A MANUFACTURED HOME --- Its largest overall length, not including bay windows, roof projections, overhangs or eaves under which there is no interior space, drawbars, couplings or hitches.

LISTED OR CERTIFIED — Included in a list published by a nationally recognized testing laboratory, inspection agency, or other organization concerned with product evaluation that maintains periodic inspection of production of listed equipment or materials, and whose listing states either that the equipment or material meets nationally recognized standards or has been tested and found suitable for use in a specified manner.

LOCAL AUTHORITY HAVING JURISDICTION (LAHJ) --- The state, city, county, city and county, municipality, utility, or organization that has local responsibilities and requirements that must be complied with during the installation of a manufactured home.

LOWEST FLOOR --- The floor of the lowest enclosed area of a manufactured home. An unfinished or flood-resistant enclosure, used solely for vehicle parking, home access, or limited storage, must not be considered the lowest floor, provided the enclosed area is not constructed so as to render the home in violation of the flood-related provisions of this standard.

MAIN FRAME — The structural component on which is mounted the body of the manufactured home.

MANUFACTURED HOME — A manufactured building designed to be used as a single family dwelling unit which has been constructed and labeled indicating compliance with the HUD administered National Manufactured Housing Construction and Safety Standards Act of 1974, as amended.

MANUFACTURED HOME CONSTRUCTION and SAFETY STANDARDS or MHCSS --- The Manufactured Home Construction and Safety Standards established in Part 3280, pursuant to section 604 of the Act, 42 U.S.C. 5403.

MANUFACTURED HOME LOT — Any space, area, or tract of land, or portion of a manufactured home park, which is designated or used for occupancy by one manufactured home.

MANUFACTURED HOME PARK — A parcel (or contiguous parcels) of land which has been so designated and improved that it contains two or more manufactured home lots available to the general public for the placement thereon of manufactured homes for occupancy.

MANUFACTURED HOME SERVICE EQUIPMENT — The equipment containing the disconnecting means, overcurrent protective devices, and receptacles or other means for connecting a manufactured home feeder assembly.

MANUFACTURED HOME SITE — A designated parcel of land designed for the installation of one manufactured home for the exclusive use of the occupants of the home.

MODEL INSTALLATION STANDARDS --- The installation standards established in part 3285, pursuant to section 605 of the Act, 42 U.S.C. 5404.

NON-COMPLIANCE — Failure of a manufactured home to comply with a Federal manufactured home construction or safety standard that does not constitute a defect, serious defect or imminent safety hazard. (See DEFECT, IMMINENT SAFETY HAZARD, and SERIOUS DEFECT)

PERSON --- A person, partnership, corporation, or other legal entity

PIER — That portion of the support system between the footing and the manufactured home, exclusive of shims. Types of piers include, but are not limited to: Manufactured steel stands; pressure-treated wood; manufactured concrete stands; concrete blocks; and portions of foundation walls.

PORCH — An outside walking area having the floor elevated more than 8 inches above grade.

POSITIVE DRAINAGE --- The configuration of the grade under and within 3 *ft.* of the perimeter of a manufactured home such that no water will collect and stand in these areas and, if the home has skirting, such that surface runoff is diverted away from the home.

PRIMARY INSPECTION AGENCY (PIA) - means a State/or private organization that has been accepted by the Secretary in accordance with the requirement of *Subpart H of 24 CFR Part 3282—Manufactured Home Procedural and Enforcement Regulations*. There are two types of PIA:

- (1) **Design Approval PIA (DAPIA)**, which evaluates and approves or disapproves manufactured home designs and quality control procedures, and
- (2) **Production Inspection PIA (IPIA)**, which evaluates the ability of manufactured home manufacturing plants to follow approved quality control procedures and provides ongoing surveillance of the manufacturing process. Organizations may act as one or both of these types.

RAMADA — Any free-standing roof, or shade structure, installed or erected above a manufactured home or any portion thereof.

READILY ACCESSIBLE --- Having direct access without the need of removing any panel, door or similar covering of the item described, and without requiring the use of portable ladders, chairs, etc.

RECREATIONAL PARK TRAILER --- A trailer type unit that is primarily designed to provide temporary living quarters for recreational, camping, or seasonal use that meets the following criteria:

- (a) Built on a single chassis mounted on wheels.
- (b) Having a gross trailer area not exceeding 400 square feet in the setup mode, and if less than 320 square feet in the setup mode would require a special movement permit for highway transit.
- (c) Certified by the manufacturer as complying with ANSI A119.5, Recreational Park Trailer Standard.

See also **Appendix D**.

RECREATIONAL VEHICLE (RV) --- A vehicular-type unit that is primarily designed as temporary living quarters for recreational, camping, or seasonal use; has its own motive power or is mounted on or towed by another vehicle; is regulated by the National Highway Traffic Safety Administration as a vehicle or vehicle equipment; does not require a special highway use permit for operation on the highways; and can be easily transported or set up on a daily basis by an individual.

See also **Appendix D**.

SECRETARY --- The Secretary of Housing and Urban Development or an official of HUD delegated the authority of the Secretary with respect to the Act.

SERIOUS DEFECT --- Any failure to comply with an applicable Federal manufactured home construction and safety standard that renders the manufactured home or any part thereof not fit for the ordinary use for which it was intended and which results in an unreasonable risk of injury or death to occupants of the manufactured home. (See DEFECT, IMMINENT SAFETY HAZARD, and NONCOMPLIANCE)

SHALL — Indicates a mandatory requirement.

SHOULD — Indicates a recommendation or that which is advised but not required.

SKIRTING — A weather-resistant material used to enclose the perimeter, under the living area of the home, from the bottom of the manufactured home to grade.

SPECIAL PERMISSION — The written consent of the authority having jurisdiction.

STABILIZING DEVICES — All components of the anchoring and support systems, such as piers, footings, ties, anchoring equipment, anchoring assemblies, or any other equipment, materials, and methods of construction, that support and secure the manufactured home to the ground.

STABILIZING SYSTEM — A combination of the anchoring system and the support system when properly installed.

SUBSTANTIAL DEFECT --- Any substantial deficiency in or damage to materials or workmanship occurring in a manufactured home which has been reasonably maintained and cared for in normal use. The term also means any structural element, utility system or component part of the manufactured home which fails to comply with the Code.

SUPPORT SYSTEM — Pilings, columns, footings, piers, foundation walls, shims, and any combination thereof that, when properly installed, support the manufactured home.

TIE --- Straps, cable, or securing devices used to connect the manufactured home to anchoring assemblies.

ULTIMATE LOAD --- The absolute maximum magnitude of load that a component or system can sustain, limited only by failure.

UTILITY CONNECTION --- The connection of the manufactured home to utilities that include, but are not limited to, electricity, water, sewer, gas, or fuel oil.

VERTICAL TIE — A tie intended to resist the uplifting and overturning forces.

WIDTH OF A MANUFACTURED HOME --- its largest overall width in the traveling mode, including cabinets and other projections which contain interior space. Width does not include bay windows, roof projections, overhangs, or eaves under which there is no interior space.

WIND ZONE --- The areas designated on the Basic Wind Zone Map, as further defined in § 3280.305(c) of the Manufactured Home Construction and Safety Standards, which delineate the wind design load requirements.

WORKING LOAD --- The maximum recommended load that may be exerted on a component or system determined by dividing the ultimate load of a component or system by an appropriate factor of safety.

Chapter 3 -- REGULATIONS FOR THE INSTALLATION OF MANUFACTURED HOMES **APPLICABLE TO ALL UNITS**

3.1 PERSONS AUTHORIZED TO SET UP MANUFACTURED HOMES

The General Statute allows manufactured homes to be set up by dealers or set-up contractors who have been licensed by the North Carolina Manufactured Housing Board. Dealers are only allowed to set-up homes that they sell from their licensed location. Pursuant to NCGS 143-143.16 (2)(b), "The dealer warrants that the set-up performed by the dealer on the manufactured home is performed in compliance with the Code." An individual may set-up his or her own home without a set-up contractor's license provided they fully comply with this Code and applicable local ordinances. However, if a homeowner is acting as his or her own contractor and hires another party to perform the work, this party must be a licensed set-up contractor and this set-up contractor shall obtain the permit and the license name and number of the set-up contractor shall appear thereon. The licenses held by a dealer or set-up contractor does not preempt the requirements of any other applicable licensing board for certain work done at the site, such as electrical hook-ups, HVAC installation, plumbing outside the perimeter of the home, etc. The licensed party or homeowner performing the set-up shall be in the remainder of this Code referred to as "the installer".

3.2 UTILITY CONNECTIONS

Manufactured home utility services shall be connected by means of approved materials. *Main* utility cut-offs shall be readily accessible (see **Chapter 2, Definitions**) for use in emergencies.

3.3 SITE PREPARATION

3.3.1 Suitability of Site

Each site shall be suitable for its intended use and acceptable to the authority having jurisdiction based on this Code and local land use regulations. *The installer should inspect the site well in advance of the arrival of the home to determine if conditions exist such as poor soil conditions, severe slope, uncompacted fill, or other factors that may require the services of a soil testing agency or consultation with a professional engineer.* If, during the inspection of the site, the installer determines that the services of a soil testing agency or professional engineer are required or that the site will require extensive grading in order to obtain proper drainage, the responsibility for securing and paying for these services shall rest with the homeowner unless otherwise agreed to by contract. If the installer has failed to inspect the site prior to the *setting* of the home, and it is determined that such services are required, the responsibility for securing and paying for these services shall rest with the installer.

3.3.2 Removal of Debris

The installer shall remove all debris from under the home after completion of the set-up.

3.3.3 Vegetation and Organic Material

All vegetation under the home shall be cut to a maximum height of 2 inches above grade. Roots, tree stumps, etc. shall be cut to grade level. ALL sod, stumps, and other organic materials shall be removed from areas where footings are to be located.

3.3.4 Proper Drainage

The area under and within a minimum of 10 ft. of the perimeter of every manufactured home shall be graded such that no water will collect and stand in these areas and such that surface runoff is diverted away from the home. The site shall be protected from runoff from adjacent areas. Such drainage may be accomplished as follows or by other acceptable practices: (See **Figure 3.3.4**)

- (1) The grade outside the home shall be sloped at a minimum of 1/2" per foot for a minimum of 10 feet on each side of the home. Where property lines, walls, slopes, or other physical conditions prohibit this slope, the site must be provided with drains or swales or otherwise graded to drain water away from the structure as shown in Figure 3.3.4.
- (2) If the ground level under the home is below outside finished grade, adequate precautionary measures shall be taken to assure positive drainage at all times. Drain tile and automatic sump pumps may be used.

In ALL cases the area under the home shall have all pockets filled and shall be reasonably smooth, and all excavations for footings shall be backfilled up to grade level to prevent entrapment of water. Manufacturers are responsible for specifying whether their homes are suitable for the installation of gutters and downspouts. If suitable, and gutters and downspouts are installed, the runoff must be directed away from the home.

3.3.5 Fire Separation

Fire separation distances must be in accordance with the requirements of 3.3.5.1 below or the requirements of the LAHJ, whichever is more stringent.

3.3.5.1 Fire Separation per Chapter 6 of NFPA 501A, 2003 Edition

No portion of a manufactured home, excluding the tongue, shall be located closer than 10 ft. side to side, 8 ft. end to side, or 6 ft. end to end horizontally from any other manufactured home or community building unless the exposed composite walls and roof of either structure are without openings and constructed of materials that will provide a 1-hour fire resistance rating or the structures are separated by a 1-hour fire rated barrier.

3.3.6 Siting of Home – Setup Contractor Responsibility

It shall be the responsibility of the setup contractor to verify that the location of the home on the site is in compliance with the LAHJ regarding encroachments in streets, yards, courts, proximity to septic systems, etc., and that permissible setback and fire separation distances (see 3.3.5 above) from property lines and public roads are met.

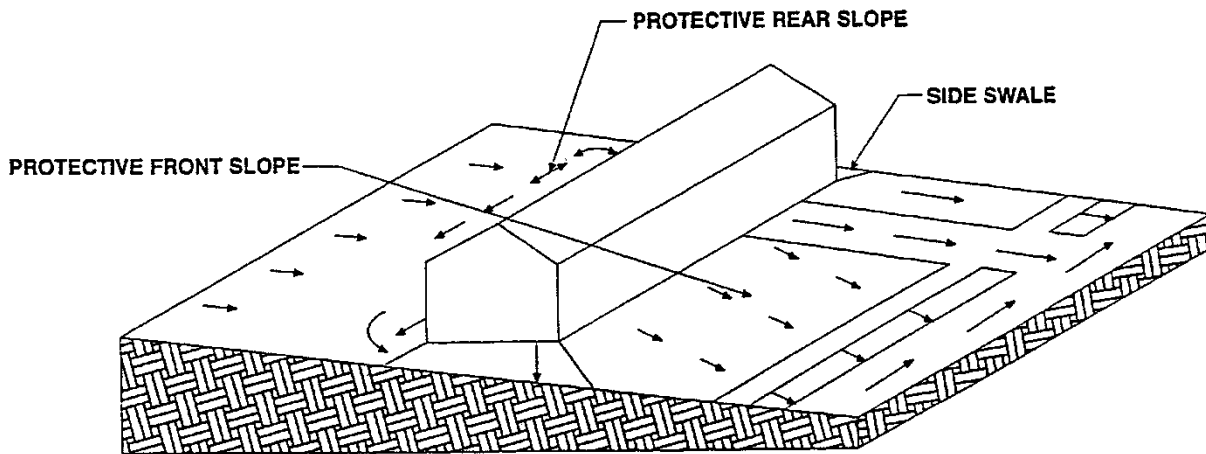

**GRADING METHOD FOR LOT WHERE SLOPE IS FROM REAR TO FRONT LOT.
DRAINAGE SWALES ARE LOCATED AT REAR AND SIDES OF DWELLING.**

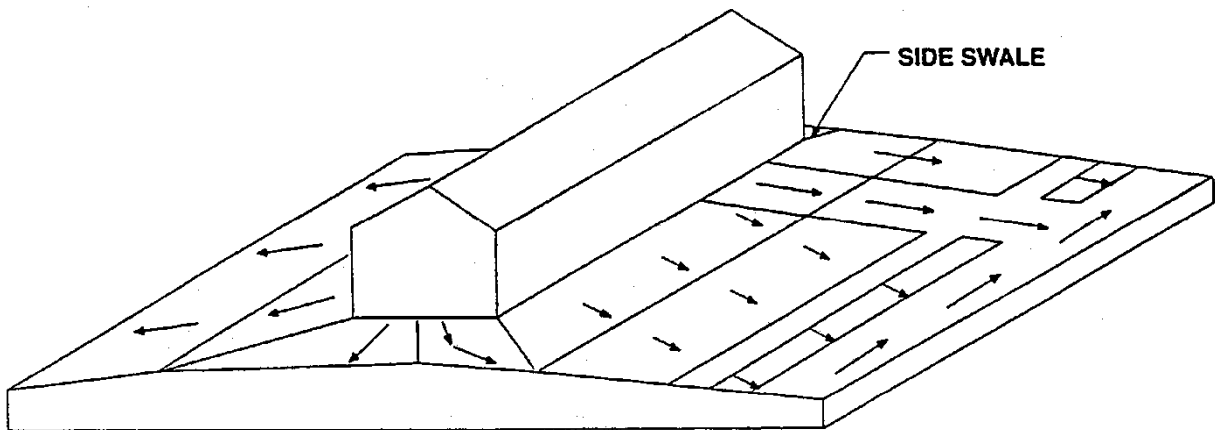

**GRADING METHOD FOR LOT WHERE DWELLING IS LOCATED ON A RIDGE.
DRAINAGE SWALES ARE LOCATED AT SIDE YARDS IN AREA OF POSITIVE SLOPES.**

FIGURE 3.3.4
Suggested Methods for Site Drainage

3.4 WIND AND THERMAL (U/O VALUE) ZONES

3.4.1 Current Wind Zones

Effective July 13, 1994 the Federal Manufactured Home Construction and Safety Standards required North Carolina to be divided into three Wind Zones: Zone I (standard), Zone II (100 mph), and Zone III (110 mph). Counties in Wind Zones II and III are listed below. *All counties not listed are in Wind Zone I.* The design wind forces established in the Federal Standards for Wind Zones II and III are based on ANSI/ASCE 7-88, Exposure “C”. If the stabilizing system for a home is designed by a professional engineer, *the criteria in ANSI/ASCE 7-88, Exposure “C” for the applicable wind velocity shall be used in the design.*

WIND ZONE II (100 MPH)

| | | |
|-----------|-------------|------------|
| Beaufort | Currituck | Pender |
| Brunswick | Jones | Perquimans |
| Camden | New Hanover | Tyrrell |
| Chowan | Onslow | Washington |
| Columbus | Pamlico | |
| Craven | Pasquotank | |

WIND ZONE III (110 MPH)

| | | |
|----------|------|------|
| Carteret | Dare | Hyde |
|----------|------|------|

3.4.2 Homes Manufactured on or after July 13, 1994

All homes with a Date of Manufacture on or after July 13, 1994 must have the applicable Wind Zone (I, II, or III) for the county where the home is to be located recorded on the Data Plate (see **Appendix I** for sample Data Plate). Anchoring and tie down requirements for the applicable Wind Zone shall be in accordance with the **Table 3.9.6** of this Code or the Manufacturer’s Installation Instructions (see **Section 1.3.1**).

3.4.3 Homes Located within 1500 feet of the Coastline (Exposure “D”)

All homes located within 1500 feet of the *coastline* (see **Chapter 2, Definitions**) in Wind Zones II and III shall have the structural system of the home and the stabilizing system designed in accordance with ASCE 7-88, Exposure “D”. Federal Standards require the Data Plate on all homes NOT designed for Exposure “D” to contain the following statement:

This home has not been designed for the higher wind pressures and anchoring provisions required for ocean/coastal areas and should not be located within 1500’ of the coastline in Wind Zones II and III, unless the home and its anchoring and foundation system have been designed for the increased requirements specified for Exposure D in ANSI/ASCE 7-88.

If a home HAS been designed for Exposure “D”, this will be indicated on the Data Plate, and the manufacturer must provide anchoring and tie down instructions specifically for Exposure “D”. *If the Data Plate of a home does not indicate design for Exposure “D”, then both the structural system of the home and the stabilizing system must be certified by a North Carolina Professional Engineer in order to be located within 1500 feet of the coastline in Wind Zones II and III.*

Where site or other conditions prohibit the use of the manufacturer’s instructions, a NC Professional Engineer or Registered Architect, in accordance with acceptable engineering practice, shall design anchorage for the special wind conditions.

3.4.4 No Home Located in Higher Wind Zone than that Indicated on Data Plate

No manufactured home shall be located in a county with a higher Wind Zone than that indicated on the Date Plate. (i.e., a Wind Zone I home shall not be located in Wind Zones II or III, a Wind Zone II home shall not be located in Wind Zone III).

- EXCEPTIONS:**
1. For a *new* home the manufacturer may provide documentation *sealed by a North Carolina professional engineer and approved by the manufacturer’s DAPIA* certifying that the home has been constructed to withstand the requirements of the higher Wind Zone. A new Data Plate shall be issued listing the higher Wind Zone, and shall be installed in the home by the manufacturer’s IPIA. The home may then be located in a higher Wind Zone county and anchoring and tie down requirements shall be as specified for the higher Wind Zone.
 2. For a *used* home a North Carolina professional engineer or his or her representative shall personally inspect and analyze the complete structural system of the home and shall provide to the local jurisdiction sealed documentation certifying that the home meets the applicable Wind Zone standards

of the Federal Manufactured Home Construction and Safety Standards effective July 13, 1994 for the higher Wind Zone, OR the engineer shall provide sealed documentation detailing instructions for any alterations that may be required to bring the home up to applicable Federal Standards for the higher Wind Zone. If such alterations are required, the engineer or his or her representative shall personally inspect the home during the process and after all work is completed and shall provide sealed documentation certifying that the alterations have been done properly. In addition, the engineer shall provide a sealed design for the entire stabilizing system for the higher Wind Zone and the engineer or his or her representative shall personally inspect the installation to insure that it has been done in accordance with the design.

3.4.5 Home Located in Lower Wind Zone than that Indicated on Data Plate

Any manufactured home may be placed in a Wind Zone that is lower than that indicated on the Data Plate (i.e., a Wind Zone II home may be placed in Wind Zone I, a Wind Zone III home may be placed anywhere in the State). However, the home need only meet the anchorage and tie down requirements for the Wind Zone where it is located.

3.4.6 Homes Manufactured before July 13, 1994.

Homes with a date of manufacture prior to July 13, 1994 will have either Wind Zone I or Wind Zone II indicated on the Data Plate. Wind Zone I homes shall be placed only in Wind Zone I counties unless the criteria of **Section 3.4.4, Exception 2** are met. Wind Zone II homes may be placed anywhere in the State. All homes manufactured prior to July 13, 1994 shall be installed in compliance with **current** anchorage and tie down requirements for the Wind Zone (I, II, or III) where they are located.

3.4.7 Thermal (U/O Value) Zones

Figure 506 in Part 3280, *Manufactured Home Construction and Safety Standards*, defines the U/O (coefficient of heat transmission) value zone for the entire state of North Carolina as **U/O Value Zone 2**. Section §3280.510 requires the following statement to appear on the Heating Certificate (found on the Data Plate):

This manufactured home has been thermally insulated to conform with the requirements of the Federal Manufactured Home Construction and Safety Standards for all locations within U/O Value Zone ____.

Local inspectors shall verify that the U/O Value Zone indicated in this statement is not less than **U/O Value Zone 2**. No home with a U/O Value Zone of 1 shall be sited anywhere within the state of North Carolina.

EXCEPTION: The U/O Value Zone 2 for the entire state became effective on October 25, 1994. Prior to this date, North Carolina had a U/O Value Zone of 1. Homes built prior to October 25, 1994 with a U/O Value Zone of 1 can be sited anywhere in the State.

3.5 FOOTINGS

3.5.1 Load Bearing Capacity of Footings

The capacity of individual piers and footings shall not be less than the tributary area of the roof, wall, and floor carried by the pier multiplied by the following design loads, which shall be assumed to act simultaneously:

| | |
|-------------------------|-------------------------|
| Roof Dead Load: 10 psf | Roof Live Load: 20 psf |
| Wall Dead Load: 5 psf | |
| Floor Dead Load: 10 psf | Floor Live Load: 40 psf |

Footings shall be of adequate size to carry the tributary loads as specified above plus the weight of the pier and the footing itself, and any concentrated load that may be imposed, without exceeding the predetermined soil bearing capacity of the site.

3.5.2 Bottom of Footings

The bottom of all footings shall be not less than that indicated in **Table 3.5.2**.

EXCEPTION 1: If a properly ventilated masonry skirt is installed around the entire perimeter of the home, the interior footings may be installed on top of the ground.

EXCEPTION 2: Per 24 CFR Part 3285.312, the bottom of all footings for NEW Homes must be at or below the frost line or minimum footing depth as indicated in Table 3.5.2 unless there is an alternate foundation plan designed by a North Carolina Professional Engineer or Registered Architect and approved by the Manufacturer and it's DAPIA that allows for higher footing levels via an insulated foundation system

The minimum footing depth for each county in North Carolina is indicated in **Table 3.5.2**.

3.5.3 Soil Bearing Capacity

Footings shall be placed on firm, level undisturbed soil or controlled fill. Controlled fill shall be free of grass and organic materials and shall be compacted to at least 90% of maximum relative density with a minimum load bearing capacity of 2000 PSF. The soil bearing capacity of the site must be determined in order to select an adequate footing size and pier spacing. Prior to setting up a home, the soil bearing capacity of the site shall be determined by the installer in accordance with one of the following:

- (a) Soil tests that are in accordance with generally accepted engineering practice.
- (b) Soil records of the applicable Local Authority Having Jurisdiction.
- (c) The pocket penetrometer method described in **Section 3.5.3.1**.

If unusual conditions are encountered, or if the soil appears to be peat or uncompacted fill, the services of a local soil testing agency, geologist, or North Carolina professional engineer will be required. If, during the inspection of the site prior to arrival of the home, the installer determines that the services of a soil testing agency, geologist, or professional engineer are required, the responsibility for securing and paying for these services shall rest with the homeowner unless otherwise agreed to by contract. If the installer has failed to inspect the site prior to the *setting* of the home and it is determined that such services are required, the responsibility for securing and paying for these services shall rest with the installer.

3.5.3.1 Soil Bearing Capacity Test Method

The use of a *pocket penetrometer* is approved for normal soil conditions. The procedure for use of the pocket penetrometer is as follows:

1. Test a typical area adjacent to or within 10 feet of the perimeter of the unit. Additional test sites may be required.
2. Dig down to the depth required for the bottom of footings as indicated in **Table 3.5.2**. The size of this excavation shall not be less than one square foot.
3. Remove the red cap from the penetrometer and push the plunger into the soil until the line on the plunger is level with the top of the soil. Record the value. Take seven such readings, eliminate the highest and lowest, and average the remaining five. Note that the penetrometer is calibrated in *tons per square foot*. Multiply the penetrometer reading by 2000 to obtain *pounds per square foot* (for example, penetrometer reads 1.5. $1.5 \times 2000 = 3000$ pounds per square foot).
4. Drive a wooden stake beside the test area and record the final average on the stake. This will allow the inspector to check or verify this reading.
5. A record of the soil bearing capacity as determined above shall be retained by the installer and furnished to the local inspector if required.

TABLE 3.5.2
Minimum Footing Depth

| | | | | | | | |
|-----------|-----|------------|----|-------------|-----|--------------|-----|
| Alamance | 4" | Cumberland | 4" | Johnston | 4" | Randolph | 4" |
| Alexander | 8" | Currituck | 4" | Jones | 4" | Richmond | 4" |
| Alleghany | 10" | Dare | 4" | Lee | 4" | Robeson | 4" |
| Anson | 4" | Davidson | 6" | Lenoir | 4" | Rockingham | 6" |
| Ashe | 10" | Davie | 6" | Lincoln | 6" | Rowan | 6" |
| Avery | 10" | Duplin | 4" | Macon | 4" | Rutherford | 6" |
| Beaufort | 4" | Durham | 4" | Madison | 6" | Sampson | 4" |
| Bertie | 4" | Edgecombe | 4" | Martin | 4" | Scotland | 4" |
| Bladen | 4" | Forsyth | 6" | McDowell | 8" | Stanly | 4" |
| Brunswick | 4" | Franklin | 4" | Mecklenburg | 6" | Stokes | 8" |
| Buncombe | 6" | Gaston | 6" | Mitchell | 10" | Surry | 8" |
| Burke | 8" | Gates | 4" | Montgomery | 4" | Swain | 6" |
| Cabarrus | 6" | Graham | 6" | Moore | 4" | Transylvania | 6" |
| Caldwell | 8" | Granville | 4" | Nash | 4" | Tyrrell | 4" |
| Camden | 4" | Greene | 4" | New Hanover | 4" | Union | 4" |
| Carteret | 4" | Guilford | 6" | Northampton | 4" | Vance | 4" |
| Caswell | 6" | Halifax | 4" | Onslow | 4" | Wake | 4" |
| Catawba | 6" | Harnett | 4" | Orange | 4" | Warren | 4" |
| Chatham | 4" | Haywood | 6" | Pamlico | 4" | Washington | 4" |
| Cherokee | 4" | Henderson | 6" | Pasquotank | 4" | Watauga | 10" |
| Chowan | 4" | Hertford | 4" | Pender | 4" | Wayne | 4" |
| Clay | 4" | Hoke | 4" | Perquimans | 4" | Wilkes | 8" |
| Cleveland | 6" | Hyde | 4" | Person | 4" | Wilson | 4" |
| Columbus | 4" | Iredell | 6" | Pitt | 4" | Yadkin | 8" |
| Craven | 4" | Jackson | 6" | Polk | 6" | Yancey | 8" |

NOTE: The bottom of all footings shall be not less than the depths indicated above, except as allowed in **Section 3.5.2, EXCEPTIONS.**

3.5.4 Footing Materials

Footing material shall consist of the following:

- (a) solid masonry (normal weight, Type I, in compliance with ASTM C90-02a, *Standard Specification for Loadbearing Concrete Masonry Units*) with a minimum thickness of 4 inches,
- (b) poured-in-place concrete pads, slabs, or ribbons with a 28-day compressive strength of not less than 3,000 psi, with a minimum thickness of 6 inches,
- (c) pressure treated lumber that is treated with a water-born adhesive in accordance with AWWA Standard U1-04 for Use Category 4B ground contact applications, or
- (d) other approved listed and labeled materials (such as ABS pads).

Pressure-treated wood footings up to 16"x16" shall consist of a minimum of two layers of nominal 2-inch thick pressure-treated wood, with the top layer laid perpendicular to the bottom layer, covered by a single layer of nominal 3/4-inch thick, pressure treated plywood. Pressure-treated wood footings of sizes greater than 16"x16" shall consist of a minimum of two layers of nominal 2-inch thick pressure-treated wood, with the top layer laid perpendicular to the bottom layer, covered by at least two layers of 3/4-inch thick, pressure-treated plywood. Plywood used in footing applications shall be rated *Exposure 1* or *exterior sheathing* in accordance with PS1-95, Construction and Industrial Plywood. When poured-in-place concrete footings are used, the home shall not be set in less than 3 days after the footings are poured.

EXCEPTION: If a high early strength concrete mix is used, the home may be set according to the specifications of the mix.

During prolonged cold spells in the winter (temp. 40 degrees F. or less), the home shall not be set in less than 7 days after the footings are poured (see EXCEPTION above for use of high early strength concrete). Deviation from the above minimum curing time for poured-in-place footings shall be permitted only with sealed documentation from a North Carolina Professional Engineer or Registered Architect, and must reflect personal investigation of site conditions by the engineer or his or her representative.

3.5.5 Footing Size

No footing, whether solid masonry, poured concrete, or other listed and labeled footing material shall be smaller than 16"x 16". A 16"x 16" or 20"x 20" footing of solid masonry may consist of either a single unit, or may be made up of two 8"x 16" or two 10"x 20" units respectively placed side by side. All masonry or concrete footings larger than 20"x 20" shall be a single unit, precast or poured.

3.5.6 Footing Orientation

A 16"x 16" or 20"x 20" footing that is made up of two units side by side shall be oriented such that the long dimension of the first course of concrete block for the pier is perpendicular to the joint between the footing blocks. (See **Figure 3.7.4.1**)

3.5.7 Concrete Slabs or Continuous Footings

If cast in place steel anchors in concrete slabs or continuous footings are used to anchor the home, then each cast in place steel anchor shall be capable of resisting a load of 4725 pounds in the direction of the tie without displacement of either the anchor or surrounding concrete. The top surface of concrete slabs or continuous footings shall be level to within 1/2" in 10 feet. Concrete for such slabs or footing shall be a minimum of 6" thick and have a minimum 28-day compressive strength of 3,000 psi. *Such anchoring systems shall be designed by a North Carolina registered engineer or architect.*

NOTE: For NEW homes, if the foundation and anchoring system is not a part of the Manufacturer's Installation Manual or an approved supplement to that manual then the foundation and anchoring system must be designed by a North Carolina Professional Engineer or Registered Architect and approved by the home manufacturer and its DAPIA in order to prevent from taking the home out of compliance with the manufacturer's warranty.

3.6 SKIRTING

3.6.1 Skirting -- General Requirements

Skirting, whether required by local ordinance or installed at the homeowner's option, shall fully comply with **Section 3.6.2**.

3.6.2 Skirting Material

Skirting shall be of material that is acceptable for exterior construction. Skirting material shall be durable and suitable for exterior exposures or provided with protection against weather deterioration at least equivalent to that provided by a coating of zinc on steel of not less than 0.30 oz./ft². Any wood framing used in the support of skirting shall be approved pressure treated wood. All wood skirting within 6 inches of the ground must be pressure-treated in accordance with AWPA Standard U1 for Use Category 4A, Ground Anchor Contact Applications, or be naturally resistant to decay and termite infestation. Skirting must not be attached in a manner that can cause water to be trapped between the siding and trim or forced up into the wall cavity trim to which it is attached. Skirting must not be attached in a manner that impedes the contraction and expansion characteristics of the home's exterior covering. Manufactured skirting material shall be installed in accordance with the skirting manufacturer's instructions. Masonry skirting or curtain walls shall be installed in accordance with **Section 3.6.3** or **Section 3.6.4**.

3.6.3 Masonry Curtain Walls not More Than 40 inches in Height

3.6.3.1 Footings for Masonry Curtain Walls Not More Than 40 inches in Height

Brick curtain walls for skirting which are not more than 40 inches in height shall be installed on a poured-in-place concrete footing with a minimum 28-day compressive strength of 3,000 psi. The footing shall be placed on firm, level, undisturbed soil or controlled fill and shall be 8 inches wide with a minimum thickness of 4 inches. The bottom of the footing shall be as indicated in **Table 3.5.2**.

EXCEPTION: Masonry curtain walls less than 40" in height may be placed on a footing made up of 8"x 16"x 4" thick solid masonry blocks. The bottom of the blocks shall be placed on firm, level, undisturbed soil or controlled fill, with the bottom of the blocks not less than the depth indicated in **Table 3.5.2**. The blocks shall be placed with no space between individual blocks, and with the 16" dimension parallel to the masonry curtain wall.

3.6.3.2 Wedges

Wedges having nominal dimensions of at least 4 inches wide and 6 inches long shall be used in pairs and shall be fitted parallel to the perimeter joist and driven tight between the top of the curtain wall and the perimeter joist of the home at not greater than 6'-0" on center. Wedges shall be of hardwood, treated wood, or other approved listed and labeled material. In no case shall wedges occupy more than 1" vertically.

3.6.3.3 Unbalanced Fill

A maximum of 6 inches of unbalanced fill, measured from the inside (under home) grade line, may be placed against masonry curtain walls that are not more than 40 inches in height. If more than 6 inches of unbalanced fill is required, then the wall must be installed as a pier and curtain wall system in accordance with **Section 3.6.4**.

3.6.4 Masonry Curtain Walls More Than 40 inches in Height

Masonry curtain walls more than 40 inches in height shall be installed as a pier and curtain wall system in accordance with the prescriptive requirements below, *or the system shall be designed and certified by a North Carolina professional engineer or architect.* (See **Figure 3.6.4**)

3.6.4.1 Prescriptive Pier and Curtain Wall Requirements

This Section assumes the use of 4 inch solid masonry for the curtain wall bonded in accordance with **Section 3.6.4.4** to 8" x 8"x 16" open cell or solid concrete masonry block or 4" solid concrete or brick masonry for piers. **The bonded pier and 4" masonry curtain wall shall not terminate below the top of the curtain wall.** The curtain wall is non-loadbearing and the piers are for lateral support of the wall only except as provided in **Section 3.6.4.7** below. Footings shall be poured-in-place concrete with a minimum 28-day compressive strength of 3,000 psi. All brick and concrete block shall be laid in Type M or S mortar.

3.6.4.2 Footings

Footings for piers shall be poured integrally with the wall footing. The minimum thickness of both the wall support and pier support areas of the footing shall be 6 inches. The section supporting the 4" curtain wall shall be 8 inches wide, and the section supporting the piers shall project not less than 2 inches beyond the edges of the pier. Piers shall be oriented such that the long dimension of the block is parallel to the wall. The bottom of the footing shall be not less than the depth indicated in **Table 3.5.2**.

3.6.4.3 Height and Pier Spacing Requirements

The maximum height of a 4" brick curtain wall shall be 67" above the top of the footing.

Pier and curtain walls higher than 67" shall be designed by a North Carolina Professional Engineer or Registered Architect. The maximum spacing of piers shall be as follows:

| | |
|----------------|-----------------|
| Wind Zone I: | 6'-0" on center |
| Wind Zone II: | 5'-0" on center |
| Wind Zone III: | 4'-4" on center |

3.6.4.4 Bonding

Each exterior pier shall laid in mortar and be bonded to the brick curtain wall with 3/16" diameter metal wall ties *or equivalent* embedded in the horizontal mortar joints or with masonry headers. The vertical spacing between ties or headers shall not exceed 24 inches.

3.6.4.5 Pier Cap

Piers shall be capped with solid concrete masonry of not less than 4 inches nominal (3 5/8" actual) thickness, or shall have

the cavities of the top course(s) solidly filled with a minimum of 8” thickness of concrete or grout.

3.6.4.6 Wedges

Wedges having nominal dimensions of at least 4 inches wide and 6 inches long shall be used in pairs and shall be fitted parallel to the perimeter joist and driven tight between the top of the pier and the perimeter joist of the home at each pier location. Wedges shall be of hardwood, treated wood, or other approved listed and labeled material. In no case shall wedges occupy more than 1” vertically.

3.6.4.7 Perimeter Support Piers

Required perimeter support piers specified by the home manufacturer may be used as part of the pier and curtain wall system so long as they are bonded to the brick curtain wall and installed in full compliance with all the provisions of **Section 3.7**.

NOTE: For NEW homes, if the foundation and anchoring system is not a part of the Manufacturer’s Installation Manual or an approved supplement to that manual then the foundation and anchoring system must be designed by a North Carolina Professional Engineer or Registered Architect and approved by the home manufacturer and its DAPIA in order to prevent from taking the home out of compliance with the manufacturer’s warranty.

3.6.4.8 Unbalanced Fill

Unbalanced fill placed against a pier and curtain wall installed in accordance with **Section 3.6.4** shall not exceed 24 inches.

3.6.5 Ventilation

All crawlspace enclosures, whether of brick or other materials, shall be ventilated in accordance with **Section 3.10**.

3.6.6 Crawl Space Access

Access shall be provided to each crawl space area by either an opening which is a minimum of 18 inches high by 24 inches wide or by panels which are removable without the use of tools.

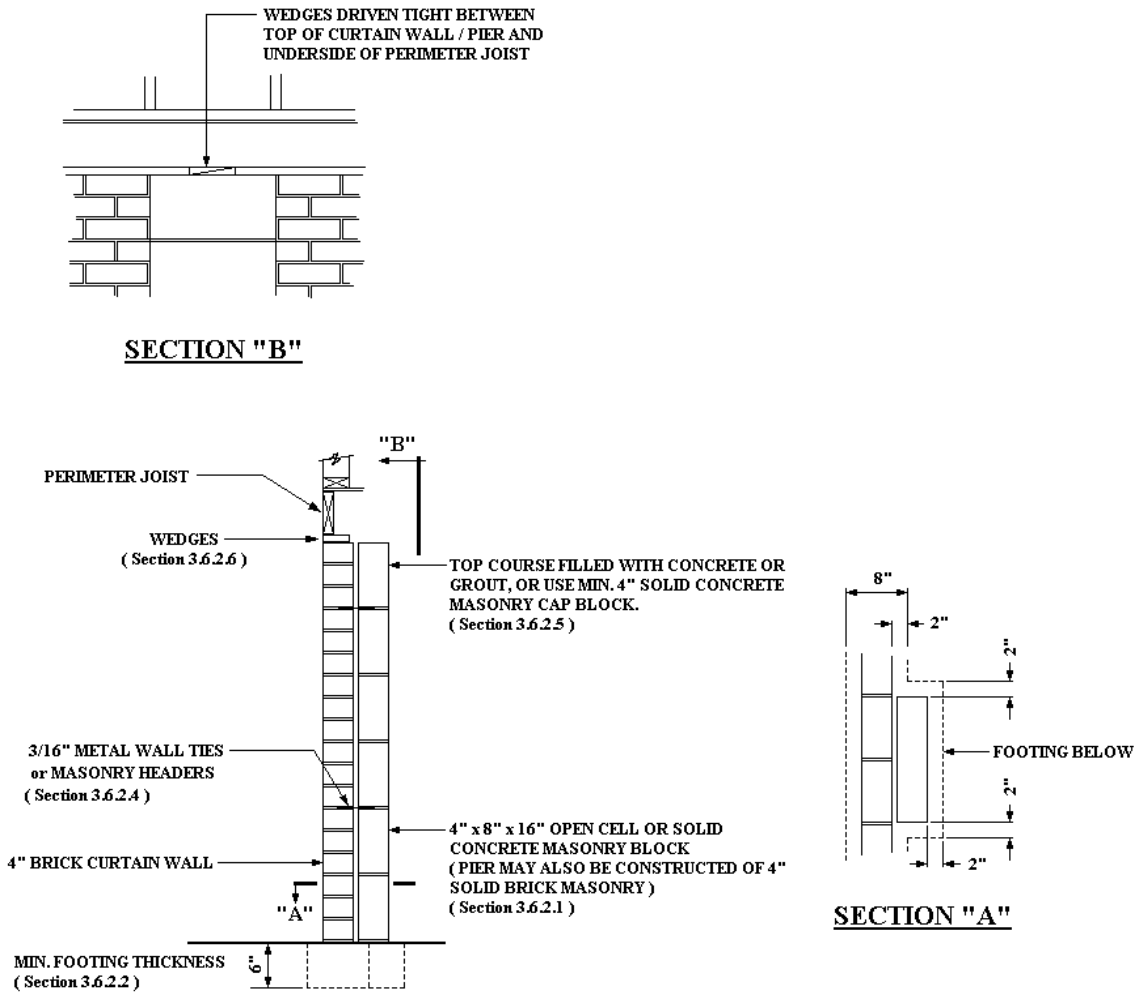

FIGURE 3.6.4
Prescriptive Pier and Curtain Wall Construction

3.7 PIERS AND PIER SPACING

3.7.1 Pier Design and Spacing -- General

3.7.1.1 Used Manufactured Homes

For USED manufactured homes the design and spacing of all main I-beam, marriage line, and perimeter support piers shall be in accordance with the requirements of **Section 3.7** of this Code, and main I-beam pier spacing shall be in accordance with **Table 3.7**, utilizing the predetermined soil bearing capacity of the site as specified in **Section 3.5.3**. Marriage line and perimeter support piers shall be located on both sides of openings of 48 inches or greater in width. Perimeter piers shall be located on both sides of side wall exterior doors (such as entry, patio, and sliding glass doors) and any other side wall openings of 48 inches or greater in width, and under load bearing porch posts, factory installed fireplaces and fireplace stoves. Footing sizes for marriage line and perimeter support piers shall be determined using the procedure given in **Section 3.7.10**.

3.7.2 Minimum Pier Height and Ground Clearance

Pier heights shall be such that a minimum clearance of 18 inches is maintained between the grade under the home and the bottom of floor joists. In addition, sufficient clearance shall be maintained between the bottom of the main frame I-beams and the grade level such that crossover ducts can be installed with required ground clearance. In no case shall the clearance between the underside of the I-beam and grade be less than 12".

3.7.2.1 Piers Set Plumb

Piers shall be set plumb such that horizontal offsets from the top to the bottom of the pier do not exceed one-half inch (1/2") for piers less than 36" high and do not exceed one inch (1") for piers 36 inches to 67 inches high. Piers over 67 inches high must be designed by an NC registered engineer or architect. The designer shall determine the acceptable tolerance for plumbness for these piers.

3.7.3 Pier Materials

Piers shall be constructed of 8"x 8" x 16" open or closed cell concrete masonry blocks, normal weight, Type I, in accordance with ASTM C90-02a, *Standard Specification for Loadbearing Concrete Masonry Units*, OR pressure-treated wood with a water borne preservative, in accordance with AWWA Standard U1-04 for Use Category 4B ground contact applications, OR listed and labeled adjustable manufactured piers, OR shall be of materials designed and certified by a North Carolina professional engineer or architect specifically for a given installation. Sealed documentation from the engineer or architect must be provided to the local official and must reflect that the engineer, architect, or his or her representative has personally inspected the specified materials and the completed installation. Listed and labeled adjustable manufactured piers shall be installed in strict compliance with the pier manufacturer's instructions. Metal or other manufactured piers shall be provided with corrosion protection at least equal to 0.30 oz./ft² of zinc surface coated on steel. The prescriptive pier design criteria given in this Section will assume the use of open cell concrete masonry block. For all piers constructed of concrete masonry blocks, whether single or double stacked, mortar is not required unless specified in the installation instructions or required by a registered professional engineer or architect for a particular installation.

NOTE: For NEW homes, if the foundation and anchoring system is not a part of the Manufacturer's Installation Manual or an approved supplement to that manual then the foundation and anchoring system must be designed by a North Carolina Professional Engineer or Registered Architect and approved by the home manufacturer and its DAPIA in order to prevent from taking the home out of compliance with the manufacturer's warranty.

3.7.4 Single Stacked Piers

3.7.4.1 Single Stacked Main I-Beam Support Piers

Subject to the limitations of **Section 3.7.7**, main I-beam support piers that are NOT MORE THAN 36 INCHES IN HEIGHT, MEASURED FROM THE GRADE LINE TO THE TOP OF THE CAP BLOCK (**See Figure 3.7.4.1**), shall be constructed of single stacked 8"x 8" x 16" concrete blocks, placed with open cells vertical. Piers shall be oriented such that the 16" dimension is perpendicular to the I-beam. **NOTE:** If the footing is installed on top of the ground as permitted in **Section 3.5.2, EXCEPTION**, the pier height shall be measured from the TOP OF THE FOOTING TO THE TOP OF THE CAP BLOCK.

3.7.4.2 Single Stacked Marriage Line and Perimeter Support Piers

Marriage line and perimeter support piers that are NOT MORE THAN 54 INCHES IN HEIGHT, MEASURED FROM THE GRADE LINE TO THE TOP OF THE CAP BLOCK (**See Figure 3.7.4.1**), shall be constructed of single stacked 8"x 8" x 16" concrete blocks, placed with open cells vertical. Marriage line piers may be oriented with the 16" dimension either perpendicular or parallel to the marriage line joists. Perimeter piers shall be oriented such that the 16" dimension is parallel to the perimeter joist, and with the outside face of the block flush with the outside face of the perimeter joist. If pier and curtain wall construction as described in **Section 3.6.4** is used, the outside face of the brick curtain wall shall be flush with the outside face of the perimeter joist. Footings for marriage line piers and perimeter piers that are not part of a pier and curtain wall system shall be sized in accordance with the procedure given in **Section 3.7.10**. **NOTE:** If the footing is installed on top of the ground as permitted in **Section 3.5.2, EXCEPTION**, the pier height shall be measured from the TOP OF THE FOOTING TO THE TOP OF THE CAP BLOCK. Single stacked perimeter piers shall be installed with the long dimension parallel to the perimeter rail.

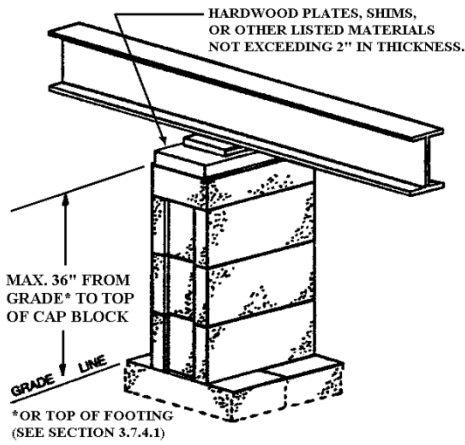

Single Stacked Main I-Beam Support Piers

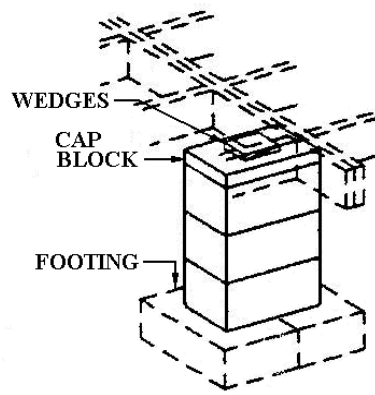

Single Stacked Marriage Line Support Piers – Perpendicular Orientation (Max. 54" from Grade Line to top of Cap Block)

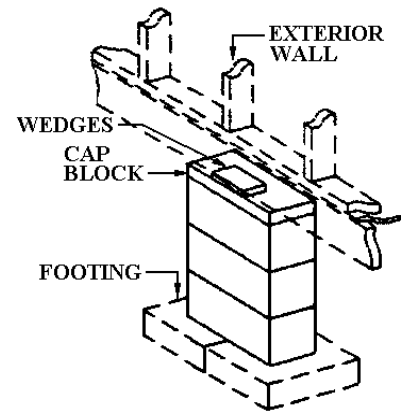

Single Stacked Perimeter Support Piers (Max. 54" from Grade Line to top of Cap Block)

**FIGURE 3.7.4.1
Typical Single Stacked Piers**

3.7.4.3 Caps Blocks for Single Stacked Piers (Applies to Main I-Beam, Marriage Line, and Perimeter Support Piers)
 Cap blocks (see Definitions) shall be 8" x 16" solid concrete masonry complying with ASTM C90-02a, not less than 4" in nominal thickness, or 2x8 nominal (1 1/2" x 7 1/4" actual dimensions) pressure treated or hardwood lumber, or 1/2" thick corrosion resistant steel or be of other listed materials. Any remaining gap between the top of the pier cap and the underside of the I-beam, marriage line joists, or perimeter joist shall be filled with either solid concrete masonry, pressure treated or hardwood lumber, and wedges as described in Section 3.7.4.4. When a solid concrete masonry cap is used, the cap directly above the top course of concrete block shall not be less than 2" in actual thickness. Solid concrete masonry less than 2" in thickness may be used as filler above the 2" minimum cap so long as it complies with ASTM C90-02a. The cumulative thickness of filler material above the top of the cap block shall not exceed 2 inches. See Figure 3.7.4.3.

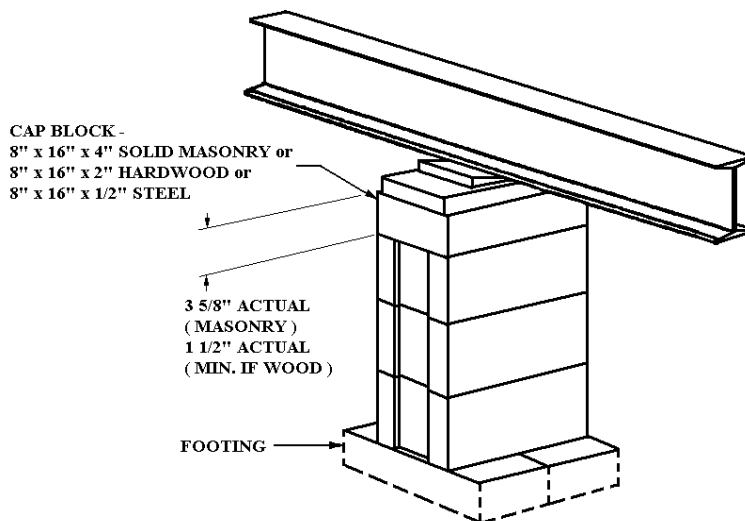

**FIGURE 3.7.4.3
Cap Blocks for Single Stacked Piers**

3.7.4.4 Wedges for Single Stacked Piers

Wedges used in filling the gap between the top of the pier cap and the underside of the I-beam, shall have actual dimensions of not less than 3 1/2" wide and 6" long. Wedges shall be of hardwood, pressure treated wood, or other approved listed and labeled materials. Wedges shall be used in pairs, opposite each other, and shall be fitted perpendicular to and driven tight to the bottom of the main I-beam or marriage line joists for main I-beam and marriage line piers. For perimeter piers wedges shall be used in pairs and shall be fitted parallel to and driven tight to the bottom of the perimeter joist. In no case shall wedges occupy more than 1" vertically.

3.7.5 Double Stacked Piers

3.7.5.1 Double Stacked Main I-Beam Support Piers

Subject to the limitations of **Section 3.7.7**, main I-beam support piers that are MORE THAN 36 INCHES BUT NOT OVER 67 INCHES IN HEIGHT, MEASURED FROM THE GRADE LINE TO THE TOP OF THE CAP BLOCK (See **Figure 3.7.5.1**), shall be constructed of double stacked 8"x 8" x 16" concrete blocks, placed with open cells vertical. Concrete blocks in double stacked piers shall be interlocked (each course placed at right angles to the previous course). When the required cap block as described in **Section 3.7.5.3** consists of two 8"x 16" blocks placed side by side, the joint between the blocks in the uppermost course (directly below the cap blocks) shall be at right angles to the joint between the cap blocks. NOTE: If the footing is installed on top of the ground as permitted in **Section 3.5.2, EXCEPTION**, the pier height shall be measured from the TOP OF THE FOOTING TO THE TOP OF THE CAP BLOCK.

3.7.5.1.1 Double Stacked Corner Piers

For the purposes of this Section "corner piers" refers to *main I-beam support piers only*, not perimeter or end wall marriage line piers. All corner main I-beam support piers MORE THAN THREE BLOCKS HIGH shall be constructed of double stacked 8"x 8" x 16" concrete blocks and shall fully comply with the requirements of **Section 3.7.5.1** above. Cap blocks shall comply with **Section 3.7.5.3**.

3.7.5.2 Double Stacked Marriage Line and Perimeter Support Piers

Marriage line and perimeter support piers that are MORE THAN 54 INCHES BUT NOT OVER 67 INCHES IN HEIGHT, MEASURED FROM THE GRADE LINE TO THE TOP OF THE CAP BLOCK (See **Figure 3.7.5.1**), shall be constructed of double stacked 8"x 8" x 16" concrete blocks and shall fully comply with the requirements of **Section 3.7.5.1** above. Double stacked perimeter piers shall be located such that the outside face of the block is flush with the outside face of the perimeter joist. If pier and curtain wall construction as described in **Section 3.6.4** is used, the outside face of the brick curtain wall shall be flush with the outside face of the perimeter joist. Footings for double stacked marriage line piers and perimeter piers that are NOT part of a pier and curtain wall system shall be sized in accordance with the procedure given in **Section 3.7.10**. NOTE: If the footing is installed on top of the ground as permitted in **Section 3.5.2, EXCEPTION**, the pier height shall be measured from the TOP OF THE FOOTING TO THE TOP OF THE CAP BLOCK.

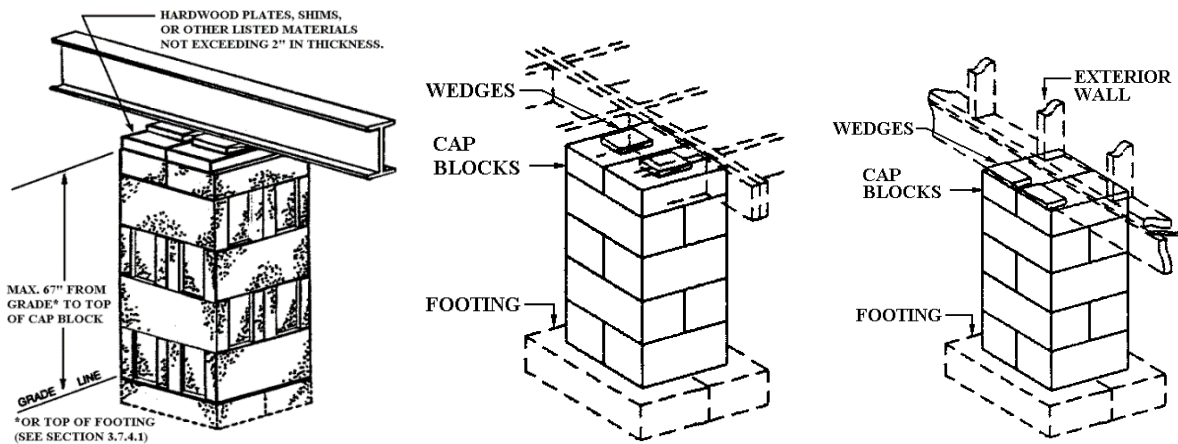

Double Stacked Main I-Beam Support Piers

**Double Stacked Marriage Line Support Piers
(Max. 67" from Grade Line to top of Cap Block)**

**Double Stacked Perimeter Support Piers
(Max. 67" from Grade Line to top of Cap Block)**

**FIGURE 3.7.5.1
Typical Double Stacked Piers**

3.7.5.3 Caps Blocks for Double Stacked Piers (Applies to Main I-Beam, Marriage Line, and Perimeter Support Piers)

Double stacked piers shall be capped with 16"x 16" solid concrete masonry of not less than 4" nominal (3 5/8" actual) thickness, OR two 8"x 16" solid concrete masonry blocks of not less than 4" nominal (3 5/8" actual) thickness placed side by side (shown in **Figure 3.7.5.3**) or be 1/2" thick for corrosion resistant steel or be of other listed materials.. Solid concrete masonry used in either of above shall comply with ASTM C90-02a. When two 8"x 16" solid concrete masonry blocks are placed side by side, the joint between the blocks shall be perpendicular to the I-beam, marriage line joists, or perimeter joist. Any remaining gap between the top of the pier cap and the underside of the I-beam, marriage line joists, or perimeter joist shall be filled with either solid concrete masonry, pressure treated or hardwood lumber, and wedges as described in **Section 3.7.5.4**. Wood filler above the masonry cap shall consist of not less than two 2x8 nominal (1 1/2" x 7 1/4" actual) x 16" long pieces placed side by side. Solid concrete masonry less than 2" in thickness may be used as filler above the cap as described above so long as it complies with ASTM C90-02a. The cumulative thickness of filler material above the top of the cap block shall not exceed 2 inches. See **Figure 3.7.5.3**.

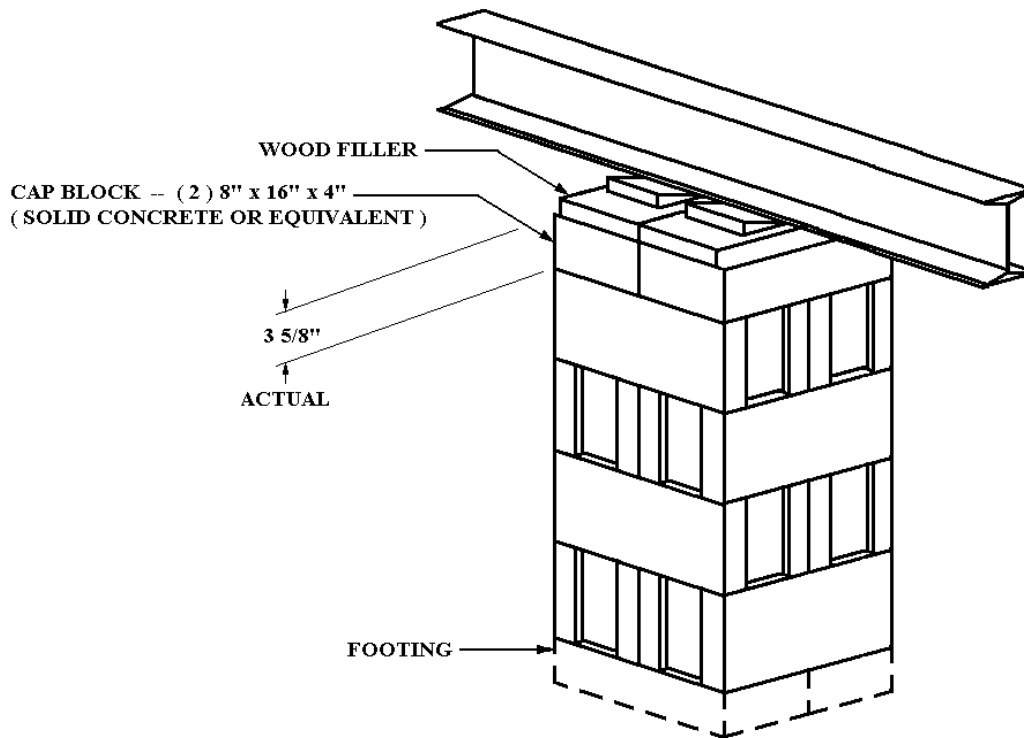

FIGURE 3.7.5.3
Cap Blocks For Double Stacked Piers

3.7.5.4 Wedges for Double Stacked Piers

Wedges used in filling the gap between the top of the pier cap and the underside of the I-beam shall have actual dimensions of not less than 3 1/2" wide and 6" long. Wedges shall be of hardwood, pressure treated wood, or other approved listed and labeled materials. Two pairs of wedges shall be used with double stacked piers. Each pair shall be installed opposite each other, fitted perpendicular to the main I-beam or marriage line joists, and driven tight to the bottom of the main I-beam or marriage line joists for main I-beam and marriage line piers. For perimeter piers the two pairs of wedges shall be fitted parallel to and driven tight to the bottom of the perimeter joist. In no case shall wedges occupy more than 1" vertically.

3.7.6 Piers Designed by Professional Engineer or Architect

Subject to the limitations of **Section 3.7.7**, all main I-beam support piers MORE THAN 67" IN HEIGHT, MEASURED FROM THE GRADE LINE TO THE TOP OF THE CAP BLOCK, and all marriage line and perimeter support piers MORE THAN 67" IN HEIGHT, MEASURED FROM THE GRADE LINE TO THE TOP OF THE CAP BLOCK, shall be designed and constructed per the drawings and specifications of a North Carolina registered engineer or architect. NOTE: If the

footing is installed on top of the ground as permitted in **Section 3.5.2, EXCEPTION 1**, the pier height shall be measured from the TOP OF THE FOOTING TO THE TOP OF THE CAP BLOCK. See **Section 3.6.3 and Section 3.6.4** for pier and curtain wall requirements.

3.7.7 Elevated Manufactured Homes

When more than one-fourth of the MAIN I-BEAM SUPPORT PIERS are greater than 36" in height, MEASURED FROM THE GRADE LINE TO THE TOP OF THE CAP BLOCK, the manufactured home stabilizing system (See **Chapter 2, Definitions**) shall be designed by a North Carolina registered engineer or architect. (NOTE: If the footing is installed on top of the ground as permitted in **Section 3.5.2, EXCEPTION**, the pier height shall be measured from the TOP OF THE FOOTING TO THE TOP OF THE CAP BLOCK.) Plans and specifications for the stabilizing system, bearing the seal of the professional engineer or architect and documenting that the engineer, architect, or his or her representative has personally inspected the site, shall be left with the homeowner or Building Official. The installation shall be subject to inspection by local the Building Official to insure compliance with the sealed design. A North Carolina registered engineer or architect who certifies an EXISTING stabilizing system where more than one-fourth of the main I-beam support piers are greater than 36" in height as described above shall provide sealed documentation stating that the engineer, architect, or his or her representative has personally inspected the site, and shall provide a thorough and detailed description of the system certified.

EXCEPTION: When a manufacturer's installation manual or a clearly marked addendum to a manufacturer's installation manual contains designs for piers exceeding the height limitations in this Section, *and such designs are sealed by a professional engineer (not necessarily registered in North Carolina)*, the use of these designs shall be acceptable when the piers are constructed and installed in strict compliance with the manufacturer's manual. HOWEVER, ALL PIERS EXCEEDING THE HEIGHT LIMITATIONS DEFINED IN **SECTION 3.7.6** SHALL BE DESIGNED AND CONSTRUCTED PER THE DRAWINGS AND SPECIFICATIONS OF A NORTH CAROLINA REGISTERED ENGINEER OR ARCHITECT.

3.7.7.1 Determination of One-Fourth of Main I-Beam Support Piers

Count the total number of main I-beam support piers. Divide this number by 4 and, if the result is not a whole number, round up to the next whole number.

Example 1: A single-wide home has 18 main I-beam support piers. $18 / 4 = 4.5$. Round up to 5. Therefore, *six* piers would have to be over 36" high as defined in **Section 3.7.7** to require an engineer or architect's sealed design.

Example 2: A double-wide home has 36 main I-beam support piers. $36 / 4 = 9$. Therefore ten piers would have to be over 36" high as defined in **Section 3.7.7** to require an engineer or architect's sealed design.

NOTE: This method shall also apply to triple-wide homes and homes with tag units, using the total number of main I-beam support piers for all sections and tag units.

3.7.8 Piers Double Stacked at Discretion of Installer

Any pier that is permitted to be single stacked by **Section 3.7.4** may be double stacked at the discretion of the installer. Cap blocks for such piers shall be in accordance with **Section 3.7.5.3**.

3.7.9 Leveling of Manufactured Homes

A manufactured home shall be considered adequately leveled if there is no more than 1/4 inch difference between adjacent pier supports (frame or perimeter) and the exterior doors and windows of the home do not bind and can be properly operated.

TABLE 3.7
MAIN I-BEAM PIER SPACING

For all USED homes with a date of manufacture prior to January 1, 2009, pier design shall comply with all the requirements of Section 3.7 of this Code and main I-beam pier spacing shall be in accordance with Table 3.7 for a given soil bearing capacity and footing size, OR the entire stabilizing system shall be designed by a North Carolina registered engineer or architect. The maximum pier spacings in this Table are calculated such that the tributary area of the roof, wall, and floor carried by the pier multiplied by the following design loads (assumed to act simultaneously), plus the pier and footing weight, does not exceed the maximum footing capacity:

Roof Dead Load: 10 psf
Wall Dead Load: 5 psf
Floor Dead Load: 10 psf

Roof Live Load: 20 psf
Floor Live Load: 40 psf

Pier and footing weights are based on an assumed 36" single stacked pier with 24x24x6 footing, or an 67" double stacked pier with 24x24x4 footing.

| SOIL CAPACITY (psf) | MINIMUM FOOTING SIZE (in. x in.) or minimum diameter in inches** | MAXIMUM FOOTING CAPACITY (lbs.) | MINIMUM FOOTING THICKNESS *** | | MAXIMUM I-BEAM PIER SPACING (See Notes 2 and 3) | | | | | |
|---------------------|--|---------------------------------|-------------------------------|---------------------|---|---------------------|------------------------|---------------------|------------------------|---------------------|
| | | | Single Stacked Pier **** | Double Stacked Pier | 12' Wide Section | | 14' Wide Section | | 16' Wide Section | |
| | | | | | Single Stacked Pier*** | Double Stacked Pier | Single Stacked Pier*** | Double Stacked Pier | Single Stacked Pier*** | Double Stacked Pier |
| 1000* | 20 x 20 (24") | 2778 | 4" | 4" | 4'-2" | 3'-0" | 3'-8" | 2'-7" | 3'-3" | 2'-3" |
| | 24 x 24 (28") | 4000 | 4" | 4" | 6'-5" | 5'-2" | 5'-7" | 4'-6" | 4'-11" | 4'-0" |
| | 30 x 30 (34") | 6250 | 5" | 4" | 10'-6" | 9'-3" | 9'-2" | 8'-1" | 8'-1" | 7'-2" |
| 1500 | 16 x 16 (20") | 2667 | 4" | 4" | 4'-0" | 2'-9" | 3'-6" | 2'-5" | 3'-1" | 2'-2" |
| | 20 x 20 (24") | 4167 | 4" | 4" | 6'-8" | 5'-6" | 5'-10" | 4'-9" | 5'-2" | 4'-3" |
| | 24 x 24 (28") | 6000 | 5" | 4" | 10'-0" | 8'-10" | 8'-9" | 7'-8" | 7'-9" | 6'-10" |
| | 30 x 30 (34") | 9375 | --- | 4" | --- | 12'-0" | --- | 12'-0" | --- | 11'-7" |
| 2000 | 16 x 16 (20") | 3556 | 4" | 4" | 5'-7" | 4'-5" | 4'-10" | 3'-10" | 4'-4" | 3'-5" |
| | 20 x 20 (24") | 5556 | 4" | 4" | 9'-3" | 8'-0" | 8'-0" | 7'-0" | 7'-2" | 6'-2" |
| | 24 x 24 (28") | 8000 | 6" | 4" | 12'-0" | 12'-0" | 11'-11" | 10'-11" | 10'-7" | 9'-8" |
| 2500 | 16 x 16 (20") | 4444 | 4" | 4" | 7'-2" | 6'-0" | 6'-2" | 5'-3" | 5'-7" | 4'-8" |
| | 20 x 20 (24") | 6944 | 5" | 4" | 11'-9" | 10'-7" | 10'-3" | 9'-2" | 9'-1" | 8'-2" |
| | 24 x 24 (28") | 10000 | --- | 4" | --- | 12'-0" | --- | 12'-0" | --- | 12'-6" |
| 3000 | 16 x 16 (20") | 5333 | 4" | 4" | 8'-10" | 7'-7" | 7'-8" | 6'-8" | 6'-10" | 5'-11" |
| | 20 x 20 (24") | 8333 | --- | 4" | --- | 12'-0" | --- | 11'-5" | --- | 10'-1" |
| 3500 | 16 x 16 (20") | 6222 | 4" | 4" | 10'-5" | 9'-3" | 9'-1" | 8'-1" | 8'-1" | 7'-2" |
| | 20 x 20 (24") | 9722 | --- | 4" | --- | 12'-0" | --- | 12'-0" | --- | 12'-0" |
| 4000 | 16 x 16 (20") | 7111 | 4" | 4" | 12'-0" | 10'-10" | 10'-6" | 9'-6" | 9'-4" | 8'-5" |
| | 20 x 20 (24") | 11111 | --- | 4" | --- | 12'-0" | --- | 12'-0" | --- | 12'-0" |

* Foundations in soil with a bearing capacity of less than 1,000 PSF must be designed by a North Carolina registered engineer or architect familiar with the site conditions.
** The minimum diameter circular footing with double stacked piers is 24".

***** For poured-in-place concrete footings, the minimum footing thickness is 6".**

****** The maximum load for a single stacked pier is 8000 lbs.**

NOTE: For NEW homes, if the foundation and anchoring system is not a part of the Manufacturer's Installation Manual or an approved supplement to that manual then the foundation and anchoring system must be designed by a North Carolina Professional Engineer or Registered Architect and approved by the home manufacturer and its DAPIA in order to prevent from taking the home out of compliance with the manufacturer's warranty.

NOTES to Table 3.7:

1. Main I-beam pier spacing shall be determined using the predetermined soil bearing capacity as described in **Section 3.5.3**, the selected footing size, and whether the pier is required to be single or double stacked in accordance with **Sections 3.7.4** and **3.7.5**. Footings shall fully comply with **Section 3.5**.
2. The maximum spacing for main I-Beam piers shall be the **LESSER** of 8'-0" for 8" deep I-Beams, 10'-0" for 10" deep I-Beams, 12'-0" for 12" deep I-Beams OR the spacings given in this Table.
3. When a pier is required to be double stacked, the spacing to the next pier on either side shall be taken from the appropriate "Double Stacked Piers" column above, whether or not the adjacent piers are required to be double stacked.
4. Spacing of piers is measured from the center of one pier to the center of the next pier.
5. Spacing of piers shall be as even as practical along the length of the I-beams.
6. Pier spacings may be exceeded by up to 10% of tabulated values so long as the average pier spacing does not exceed tabulated values.
7. Piers shall extend at least 6 inches on both sides of the supported I-beam.
8. The maximum distance to the centerline of the first pier at each end of the home shall be 2'-0".
9. Alternate footing materials (see **Section 3.5.4**) shall be utilized and installed in accordance with their listing.

Examples

1. For a 14' wide section with 10" deep I-beams, if the soil capacity is 3000 psf, a 16" X 16" footing is used and the piers are single stacked, space piers at 7'-8" center to center.
2. For a 12' wide section with 8" deep I-beams, if the soil capacity is 2500 psf, a 20" X 20" footing is used, and the piers are double stacked, space piers at 8'-0" center to center. (See Note 2 above).

3.7.10 Procedure for Determining Footing Size for Marriage Line and Perimeter Piers

This procedure is to be followed for all USED homes with a date of manufacture prior to January 1, 2009.

1. Determine the ridge beam or perimeter header span using **Figure 3.7.10** as a guide.
2. Find the span in the column entitled “Ridge Beam or Header Span” in **Table 3.7.10A**. The required height of the pier will determine whether it is single stacked or double stacked, in accordance with **Sections 3.7.4.2** and **3.7.5.2**. From the appropriate column designating the width of the home and whether the pier is single stacked or double stacked, read the load for which the footing must be sized. **NOTE: FOR PERIMETER PIERS, USE ONE-HALF OF THE LOAD GIVEN IN THE TABLE.**
3. Using the predetermined soil bearing capacity as specified in **Section 3.5.3**, enter **Table 3.7.10B** and find the first number in the column “Maximum Footing Capacity” that is equal to or greater than the load determined in step 2 above. On this same line, the Minimum Footing Size and Minimum Footing Thickness (depending on whether the pier is single or double stacked) is given.

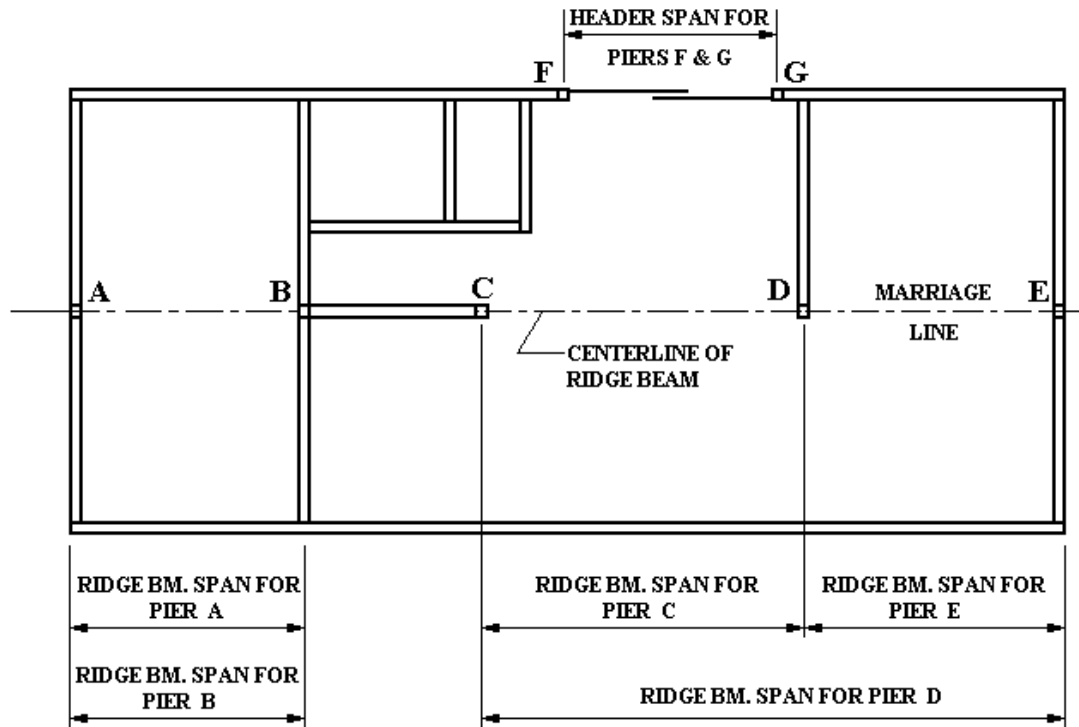

FIGURE 3.7.10
Ridge Beam and Header Spans for Marriage Line
and Perimeter Piers

TABLE 3.7.10A
COLUMN LOADS FOR USE IN DETERMINING FOOTING SIZE
FOR MARRIAGE LINE AND PERIMETER PIERS

The footing loads in this Table are calculated using the tributary area of roof carried by a ridge beam or perimeter header multiplied by the following design loads, plus the pier and footing weight:

Roof Dead Load: 10 psf
 Roof Live Load: 20 psf

Pier and footing weights are based on an assumed 56" single stacked pier with 24x24x6 footing, or a 96" double stacked pier with 24x24x4 footing.

| RIDGE BEAM OR HEADER SPAN (ft.) See Fig. 3.7.10 | LOADS FOR SIZING OF FOOTINGS (lbs.) | | | | | |
|---|--|---------------------------|---------------------------|---------------------------|---------------------------|---------------------------|
| | 24' WIDE | | 28' WIDE | | 32' WIDE | |
| | Single Stacked Pier | Double Stacked Pier | Single Stacked Pier | Double Stacked Pier | Single Stacked Pier | Double Stacked Pier |
| Over 4 to 8 | 2122 | 2880 | 2362 | 3120 | 2602 | 3360 |
| Over 8 to 12 | 2902 | 3660 | 3262 | 4020 | 3622 | 4380 |
| Over 12 to 16 | 3682 | 4440 | 4162 | 4920 | 4642 | 5400 |
| Over 16 to 20 | 4462 | 5220 | 5062 | 5820 | 5662 | 6420 |
| Over 20 to 24 | 5242 | 6000 | 5962 | 6720 | 6682 | 7440 |

NOTES to Table 3.7.10A:

1. For **perimeter** piers, use **one-half** the load given in this Table.
2. Single stacked and double stacked piers shall be in accordance with the height limitations of **Sections 3.7.4.2 and 3.7.5.2.**

TABLE 3.7.10B
Marriage Line and Perimeter Pier Footing Size and Thickness

| SOIL CAPACITY (psf) | MINIMUM FOOTING SIZE (in. x in.) or minimum diameter in inches** | MAXIMUM FOOTING CAPACITY (lbs.) | MINIMUM FOOTING THICKNESS *** | |
|---------------------|--|---------------------------------|-------------------------------|---------------------|
| | | | Single Stacked Pier **** | Double Stacked Pier |
| 1000* | 20 x 20 (24") | 2778 | 4" | 4" |
| | 24 x 24 (28") | 4000 | 4" | 4" |
| | 30 x 30 (34") | 6250 | 5" | 4" |
| 1500 | 16 x 16 (20") | 2667 | 4" | 4" |
| | 20 x 20 (24") | 4167 | 4" | 4" |
| | 24 x 24 (28") | 6000 | 5" | 4" |
| | 30 x 30 (34") | 9375 | --- | 4" |
| 2000 | 16 x 16 (20") | 3556 | 4" | 4" |
| | 20 x 20 (24") | 5556 | 4" | 4" |
| | 24 x 24 (28") | 8000 | 6" | 4" |
| 2500 | 16 x 16 (20") | 4444 | 4" | 4" |
| | 20 x 20 (24") | 6944 | 5" | 4" |
| | 24 x 24 (28") | 10000 | --- | 4" |
| 3000 | 16 x 16 (20") | 5333 | 4" | 4" |
| | 20 x 20 (24") | 8333 | --- | 4" |
| 3500 | 16 x 16 (20") | 6222 | 4" | 4" |
| | 20 x 20 (24") | 9722 | --- | 4" |
| 4000 | 16 x 16 (20") | 7111 | 4" | 4" |
| | 20 x 20 (24") | 11111 | --- | 4" |

* Foundations in soil with a bearing capacity of less than 1,000 PSF must be designed by a North Carolina registered engineer or architect familiar with the site conditions.

** The minimum diameter circular footing with double stacked piers is 24".

*** For poured-in-place concrete footings, the minimum footing thickness is 6".

**** The maximum load for a single stacked pier is 8000 lbs.

NOTE: For NEW homes, if the foundation and anchoring system is not a part of the Manufacturer's Installation Manual or an approved supplement to that manual then the foundation and anchoring system must be designed by a North Carolina Professional Engineer or Registered Architect and approved by the home manufacturer and its DAPIA in order to prevent from taking the home out of compliance with the manufacturer's warranty.

NOTE to Table 3.7.10B:

1. Soil bearing capacity shall be determined as specified in Section 3.5.3.

Section 3.7.10 Procedure Examples

1. A 28' wide home on a site with a soil bearing capacity of 1500 psf has a 48" high marriage line pier with openings on both sides (**Pier "D" in Figure 3.7.10**). The opening on one side of the pier has a span of 9'-8", and the other opening has a span of 11'-0". The ridge beam span for the pier is therefore 9'-8" + 11'-0" = 20'-8". Per **Section 3.7.4.2**, a 48" marriage line pier may be single stacked. In **Table 3.7.10A**, go to the last line in the left column ("Over 20 to 24"), and **Section 3.7.10 Procedure Examples (cont'd.)**

under the 28' wide, single stacked pier column, read a footing load of **5962 lbs.** In **Table 3.7.10B**, go to 1500 psf in the left column and, in the "Maximum Footing Capacity" column, find the first value in the 1500 psf section that equals or exceeds 5962 lbs. This value is 6000 lbs. On the 6000 lbs. line, read 24x24 in the "Minimum Footing Size" column and 5" in the "Minimum Footing Thickness, Single Stacked Pier" column. The required minimum footing size for this pier is therefore **24" x 24" x 5"**.

2. A 32' wide home on a site with a soil bearing capacity of 2000 psf has a 64" high perimeter piers on either side of an opening that spans 8'-0" (**Piers "F" and "G" in Figure 3.7.10**). Per **Section 3.7.5.2**, a 64" perimeter pier must be double stacked. In **Table 3.7.10A**, go to the line in the left column that reads "Over 4 to 8" (since the span is exactly 8'), and under the 32' wide, double stacked pier column, read a footing load of **3360 lbs.** Since these are perimeter piers, use **one-half** of the **Table 3.7.10A** load. The required load is **3360 divided by 2, or 1680 lbs.** In **Table 3.7.10B**, go to 2000 psf in the left column and, in the "Maximum Footing Capacity" column, find the first value in the 2000 psf section that equals or exceeds 1680 lbs. This value is 3556 lbs. On the 3556 lbs. line, read 16x16 in the "Minimum Footing Size" column and 4" in the "Minimum Footing Thickness, Double Stacked Pier" column. The required minimum footing size for the piers is therefore **16" x 16" x 4"**.

3.7.11 Marriage Line and Perimeter Piers -- Interference with Outriggers

Marriage line and perimeter piers may be shifted slightly to avoid interference with outriggers, so long as no part of the column above extends beyond the edge of the pier. Footings shall be centered under the piers.

3.7.12 Marriage Line Piers -- Allowable Offset

Marriage line piers may be offset a maximum of 6 inches in either direction along supported members to allow for plumbing, electrical, mechanical equipment, or other devices.

3.8 MULTI-SECTION CONNECTIONS

3.8.1 Multi-Section Homes -- General Provisions

3.8.1.1 Used Manufactured Homes

Marriage line connections for all USED homes **with a date of manufacture prior to January 1, 2009** shall comply with all the requirements of **Section 3.8** of this Code.

3.8.2 Preparation for Marriage Line Connections

Prior to joining the sections of a multi-section home, the home shall be prepared according to the following:

1. Remove all shipping materials from the marriage line floor, wall, and roof areas between the sections so that there are no exposed or protruding fasteners, material scraps, or other protrusions on either side of the marriage line.
2. Install an air infiltration barrier on the mating edges of the floor, end walls, and ceiling consisting of closed cell foam, sill seal, or a durable, non-porous caulking that is capable of expansion and contraction. If sill seal is used, it shall be a minimum of 5 1/2" wide and shall be doubled over and attached with fasteners staggered at 6" on center. The air infiltration barrier shall be installed such that no gaps occur at any point along the mating edges of the floor, end walls, and ceiling.

3.8.3 Prescriptive Marriage Line Connections for Manufactured Homes

For all USED manufactured homes **with a date of manufacture prior to January 1, 2009**, the methods described in the following Sections are acceptable. Alternate methods may be accepted at the discretion of the local building official provided they are structurally equivalent to or better than the methods in this Section.

3.8.3.1 Ridge Connections

Ridge connections may be accomplished by any of the following methods:

3.8.3.1.1 Ridge Connection Method 1

Space 3/8"x 6" minimum lag screws with washers on each side of ridge at a maximum of 36" o.c. for Wind Zone I, 20" for Wind Zone II, and 16" for Wind Zone III. Stagger the lags on each side of the ridge, making sure that the lag screw engages the top chords of the ridge beams on each section and the web of the opposite ridge beam (in the case of I-joist type ridge beams), or that the lag screw fully penetrates the thickness of the ridge beams on each section (in the case of solid or multiply ridge beams). **See Fig. 3.8.3.1.1.**

3.8.3.1.2 Ridge Connection Method 2

Space #8 x 4" screws at 32" o.c. max or 16d nails at 16" o.c. staggered side to side at the ridge. Place a 30 gauge x 6" wide minimum galvanized steel continuous strap the full length of unit fastened on each side of centerline with 7/16" x 16 GA staples or 1 1/2" galvanized roofing nails at 2" o.c. maximum through roof deck. Overlap strap a minimum of 4" at the splice overlap. A means must be provided to support the galvanized steel strap for the full length of the ridge line in order to prevent bending at the peak if accidentally stepped on by workers, etc.

See Fig. 3.8.3.1.2.

3.8.3.1.3 Ridge Connection Method 3

Space #10 x 4" screws at 12" o.c. staggered from side to side at 30° from vertical. Place 26 GA x 1 1/2" strap attached with (8) 15 GA x 1 1/2" staples per end or (4) #10 x 1 1/2" screws per end over trusses at a maximum spacing of 96" o.c. for Wind Zones I & II and 80" o.c. for Wind Zone III. **See Fig. 3.8.3.1.3.**

| Wind Zone | Max. Lag Spacing |
|-----------|------------------|
| I | 36" |
| II | 20" |
| III | 16" |

* LAG SPACING TABLE

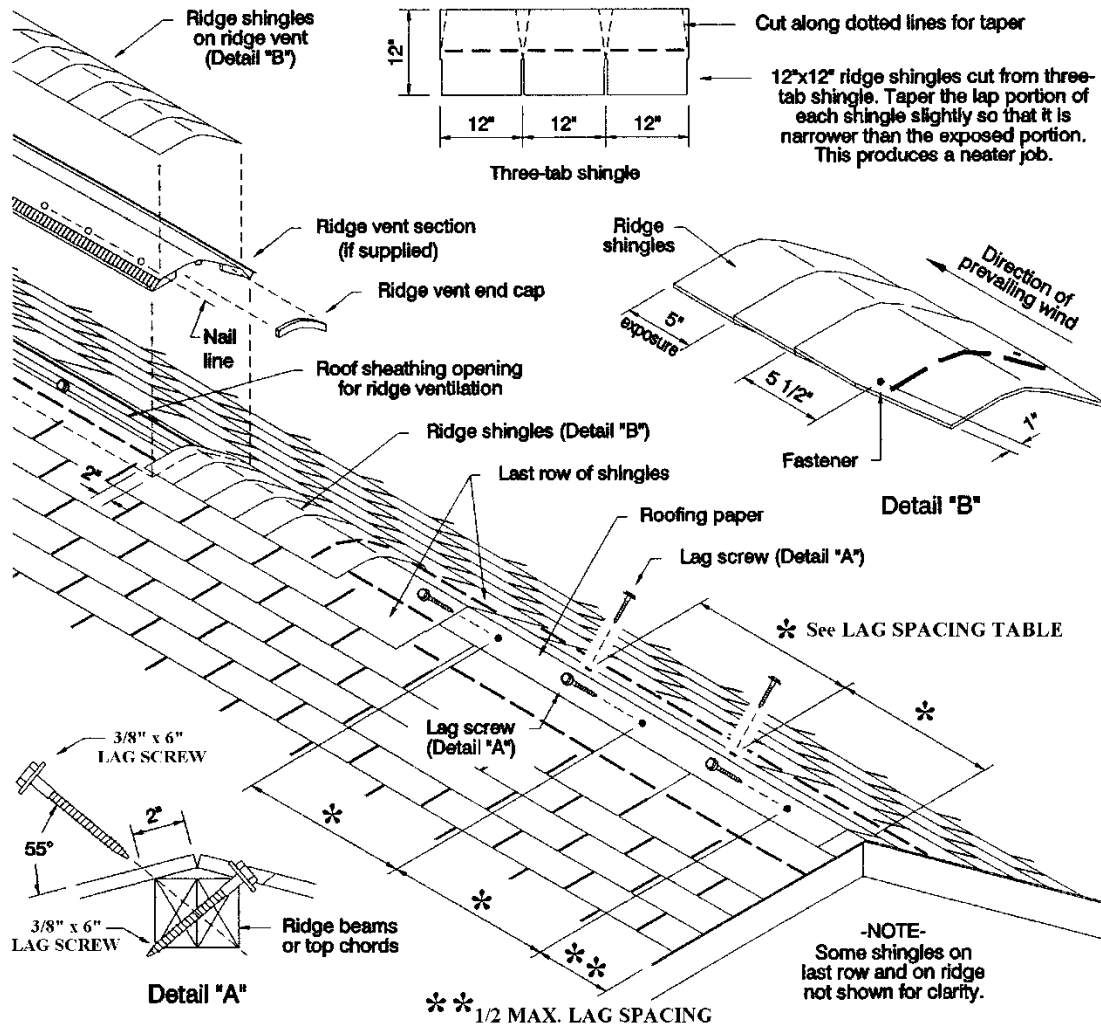

FIGURE 3.8.3.1.1
Ridge Connection Method 1

See General Notes for Ridge Connections, located after Figure 3.8.3.1.3.

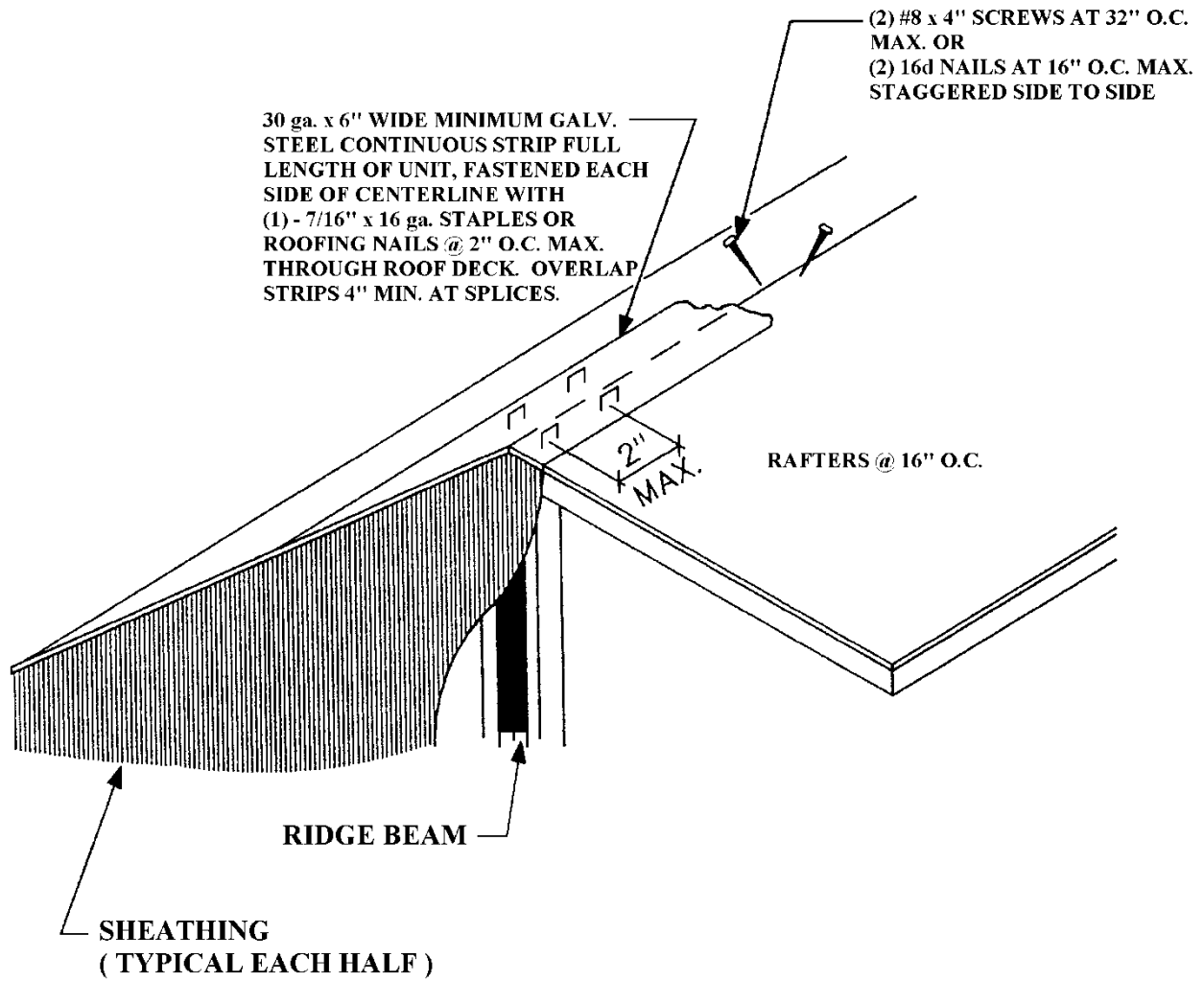

FIGURE 3.8.3.1.2
Ridge Connection Method 2

See **General Notes for Ridge Connections**, located after **Figure 3.8.3.1.3**.

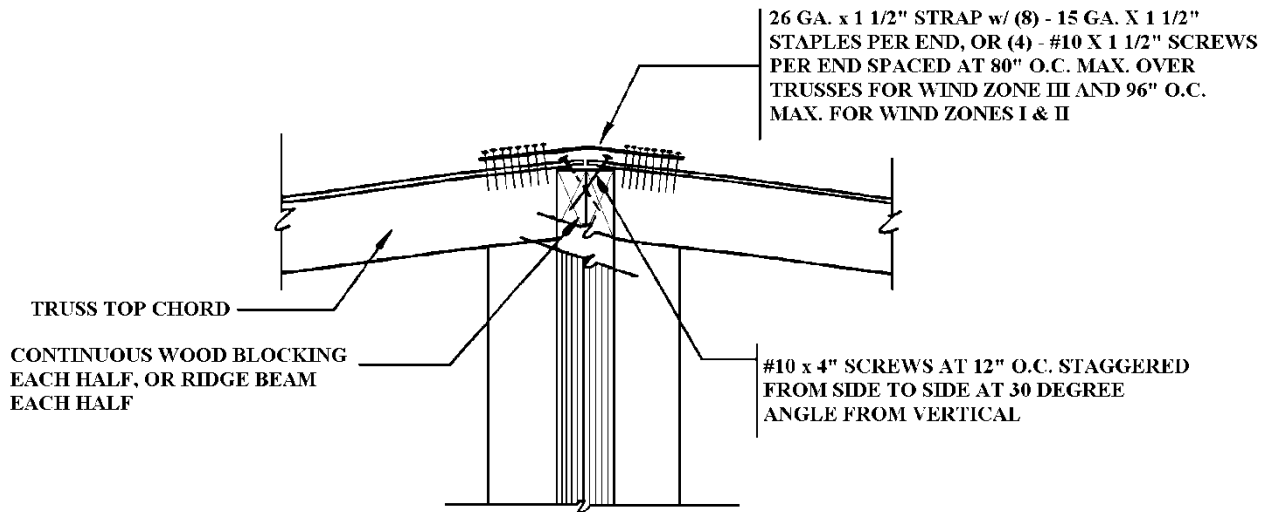

FIGURE 3.8.3.1.3
Ridge Connection Method 3

GENERAL NOTES FOR RIDGE CONNECTIONS (applies to **Ridge Connection Methods 1 through 3**)

1. A maximum gap of 1" is permitted between ridge beams or top chords. Prior to exterior close-up all gaps between units must be shimmed full length.
2. Shims shall be dimension lumber and shall be at least as deep as the ridge beam or top chord. Fastener length must be increased as necessary to maintain at least 1 1/2" penetration into the main member.
3. Where no ridge vent is installed, means must be provided for continuous support of the shingles at the ridge line.
4. All shingles damaged by shipping nails or staples must be replaced or repaired.

3.8.3.2 Floor Connections

Floor connections may be accomplished by any of the following methods:
(See **General Notes for Floor Connections**, located after **Figure 3.8.3.2.4**)

3.8.3.2.1 Floor Connection Method 1

Space 3/8" x 6" minimum lag screws at approximately 30° to vertical staggered side to side through the floor sheathing from the top. Recess lag heads into the floor decking and fill with wood putty or water based putty. Space lags on each side at 36" o.c. for Wind Zone I, 20" for Wind Zone II, and 16" for Wind Zone III. **See Figure 3.8.3.2.1.**

3.8.3.2.2 Floor Connection Method 2

Same as Method (1) except attached from bottom of mating floor members. **See Figure 3.8.3.2.2.**

3.8.3.2.3 Floor Connection Method 3

Space 3/8" x 4" minimum lag screws in two staggered rows with each row spaced at 36" o.c. for Wind Zone I, 20" for Wind Zone II, and 16" for Wind Zone III. Bolts of sufficient length may be used in lieu of lags for floor connections only. Floors should be leveled between units to eliminate offsets in the floor. **See Figure 3.8.3.2.3.**

3.8.3.2.4 Floor Connection Method 4

Space 3/8" x 3 1/2" lag screws on each side at 24" o.c. staggered side to side at 45° angle from vertical. Attach a 26 GA x 1 1/2" steel strap over opposite unit joists with (1) 3/8" x 3 1/2" lag screw into each joist at the ends of the strap. Space straps 32" o.c. maximum. **See Figure 3.8.3.2.4.**

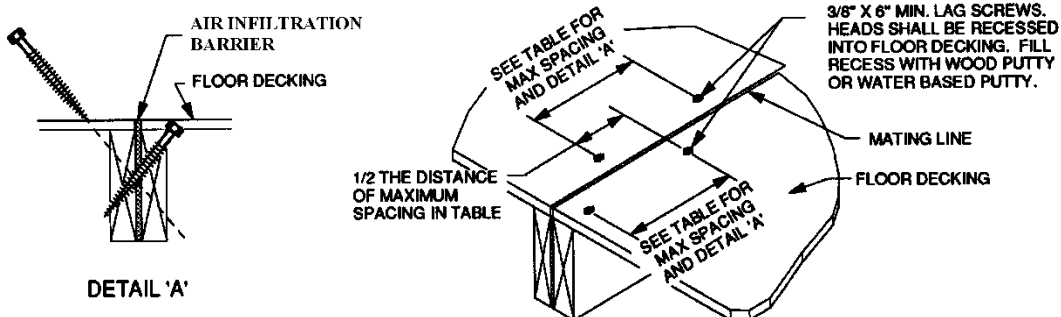
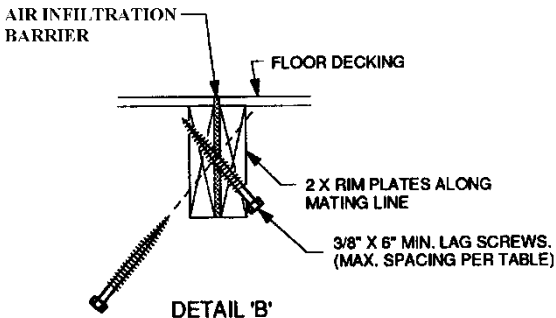

FIGURE 3.8.3.2.1
Floor Connection Method 1

| LAG SCREW MAXIMUM SPACING | |
|------------------------------|-------------------------|
| WIND ZONE | MAXIMUM O.C. SPACING |
| I | 36" |
| II | 20" |
| III | 16" |



- Note:
1. Bottom board not shown for clarity.
 2. Holes in bottom board created by lag screws must be patched with a vinyl tape designed for repairing tears or holes.

FIGURE 3.8.3.2.2
Floor Connection Method 2

| LAG SCREW MAXIMUM SPACING | |
|------------------------------|-------------------------|
| WIND ZONE | MAXIMUM O.C. SPACING |
| I | 36" |
| II | 20" |
| III | 16" |

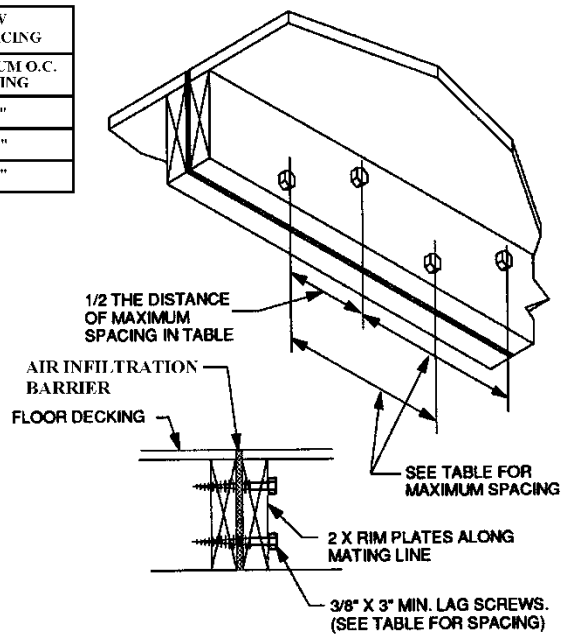

Note:

1. Bottom board not shown for clarity.
2. Holes in bottom board created by lag screws must be patched with a vinyl tape designed for repairing tears or holes.

FIGURE 3.8.3.2.3
Floor Connection Method 3

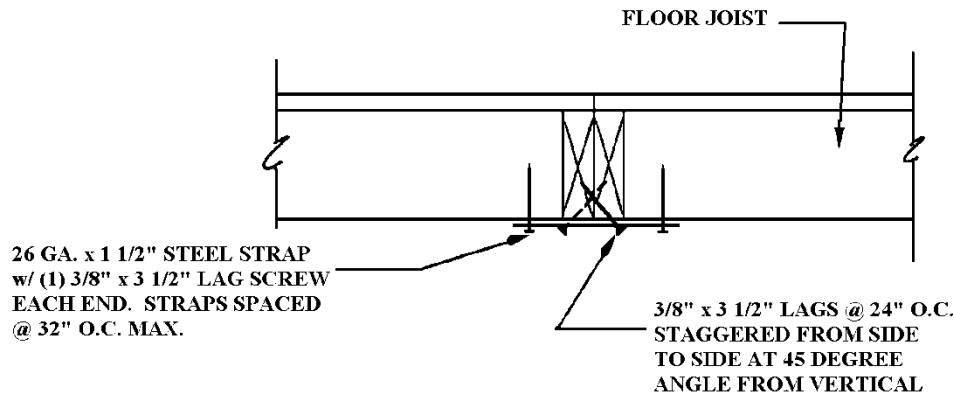

FIGURE 3.8.3.2.4
Floor Connection Method 4

GENERAL NOTES FOR FLOOR CONNECTIONS (applies to **Floor Connection Methods 1 through 4**)

1. A maximum gap of 1" is permitted between mate line rim joists. Prior to exterior close-up all gaps between units must be shimmed full length.
2. Shims shall be dimension lumber and shall be at least as deep as the mate line rim joists. Fastener length must be increased as necessary to maintain at least 1 1/2" penetration into the main member.
3. All marriage line gaps must be draftstopped.

3.8.3.3 Endwall Connections

Endwall connections may be accomplished as follows:

Space #8 x 4" wood screws staggered along marriage endwall at 12" o.c. (24" o.c. on each side). Place screws at an angle of approximately 45 degrees such that framing in each unit will be fully engaged. See Figure 3.8.3.3.

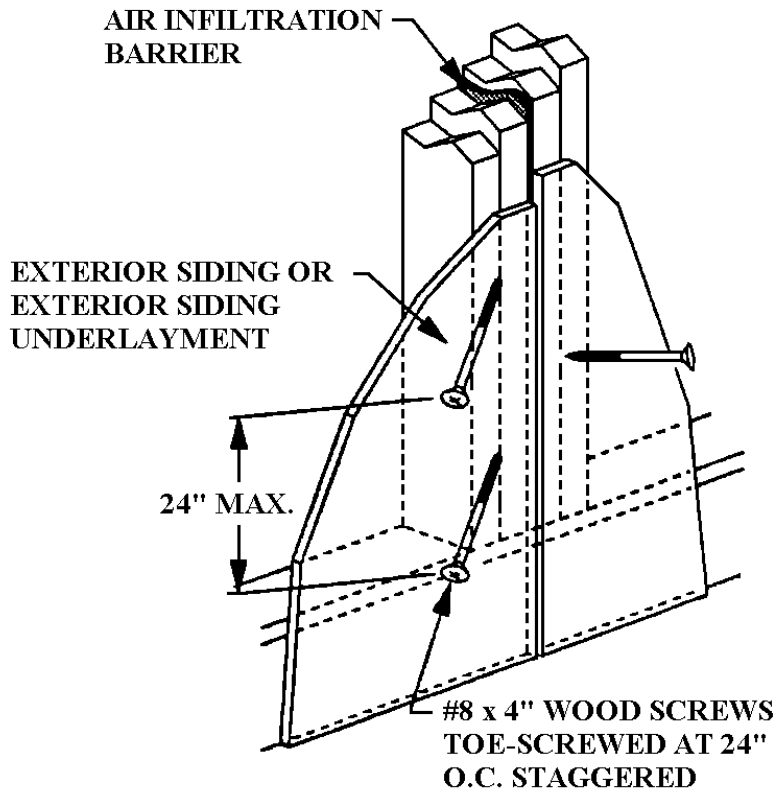

FIGURE 3.8.3.3
Endwall Connection

NOTES FOR FIGURE 3.8.3.3

1. A maximum gap of 1" is permitted between endwall mate studs. Prior to exterior close-up all gaps between units must be shimmed full length.
2. Shims shall be dimension lumber and shall be at least as deep as the mate line rim joists. Fastener length must be increased as necessary to maintain at least 1 1/2" penetration into the main member.

3.8.3.4 Marriage Wall Door & Case Opening Connections

Marriage wall door and case opening connections may be accomplished as follows:

Place (4) #10 x 4 1/2" wood screws through jack studs from one half to the other on each side of the opening. See Figure 3.8.3.4.

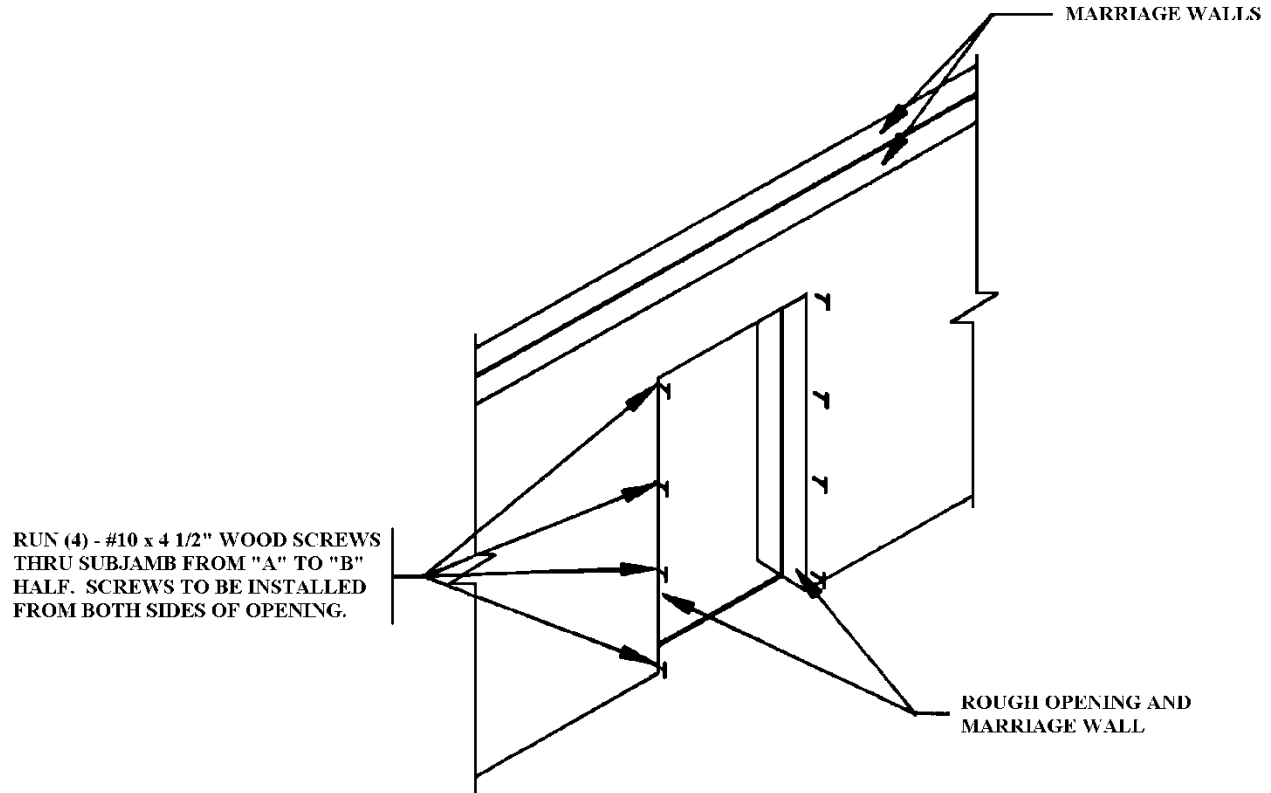

FIGURE 3.8.3.4
Marriage Wall Door & Case Opening Connection

NOTES FOR FIGURE 3.8.3.4

1. A maximum gap of 1" is permitted between marriage wall mate studs. Prior to exterior close-up all gaps between units must be shimmed full length.
2. Shims shall be dimension lumber and shall be at least as deep as the marriage wall mate studs. Fastener length must be increased as necessary to maintain at least 1 1/2" penetration into the main member.
3. All gaps at the sides and top of marriage wall door and case openings shall be firestopped.

3.8.3.5 Marriage Wall Ceiling Connections

Marriage wall ceiling connections may be accomplished as follows:

On units having vaulted ceilings a connection at the apex of the ceiling may be required. When this connection is required, place a 2" x 6" wood member along the ceiling apex and install (2) #10 x 4 1/2" wood screws, one in each ridge member at 24" o.c. See **Figure 3.8.3.5**

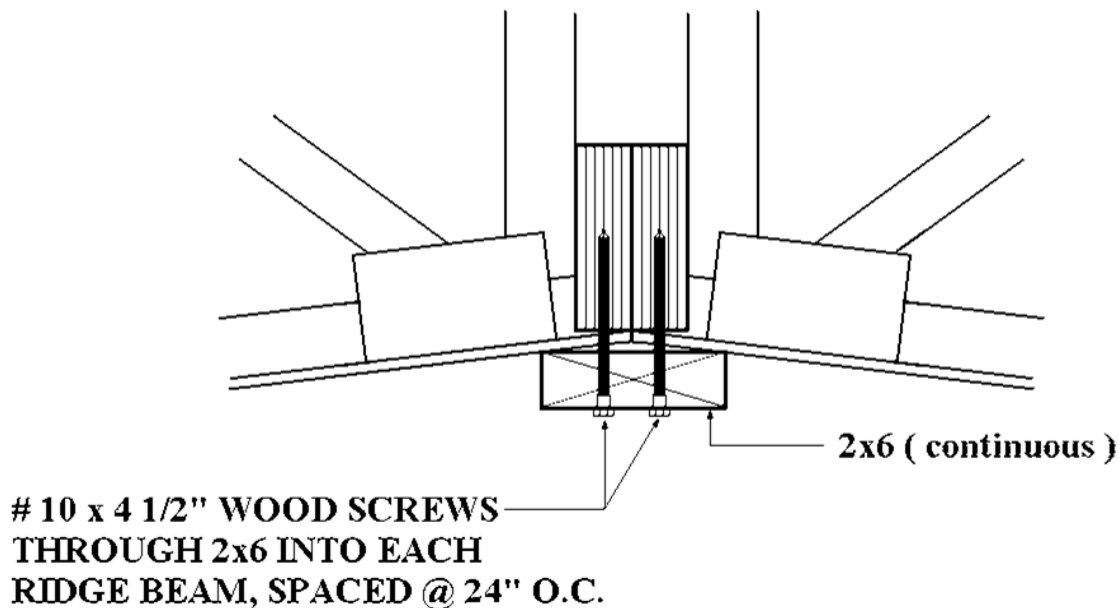

FIGURE 3.8.3.5
Marriage Wall Ceiling Connection

NOTE FOR FIGURE 3.8.3.5

1. Part 3280, *Manufactured Home Construction and Safety Standards*, Section §3280.206 requires that any concealed space communicating with the roof cavity be firestopped with at least 1" nominal lumber, 5/16" thick gypsum board, or equivalent. In areas where a continuous 2x6 as shown in **Figure 3.8.3.5** is not present, or if an alternate method is used for the marriage wall ceiling connection, any gap that occurs between the ridge beams must be firestopped as described above.
2. A maximum gap of 1" is permitted between ridge beams. Prior to exterior close-up all gaps between units must be shimmed full length.
3. Shims shall be dimension lumber and shall be at least as deep as the ridge beam or top chord. Fastener length must be increased as necessary to maintain at least 1 1/2" penetration into the main member.

3.8.4 Roofing Application

Multi-section units commonly require that a portion of the roof covering be site-installed. Prior to completing the exterior close-up, any holes in the roofing must be made weatherproof and sealed with a sealant or other material suitable for use with the roofing in which the holes occur. Any damaged shingles or roofing must be replaced or repaired. All site-installed roofing shall be in accordance with the manufacturer's installation instructions, but at a minimum the following:

3.8.4.1 Metal Roof

1. **Sealing.** Sealing is required between the site-installed metal ridge cap and the factory-installed portion of the metal roof. Additional approved exterior sealants are usually required along the edges of the ridge cap.
2. **Overlap.** The metal ridge cap shall overlap the factory-installed portion of the metal roof.
3. **Fasteners.** The type, quality, spacing and penetration of the fasteners shall be in accordance with the roofing manufacturer's instructions.

3.8.4.2 Shingle Roof

1. **Sheathing.** Connection of the mate beams may require that a portion of the roof sheathing be installed at the site. The appropriate sheathing shall be installed in accordance with the manufacturer's installation instructions.
2. **Underlayment.** Roofing felt paper shall be sufficiently overlapped and fastened.
3. **Shingle Application.** Each succeeding layer shall have the proper exposure to the weather. Joints between each course shall be staggered so they do not align with the space between the tabs (cut-outs). The manufacturer may require that the shingles be cut at the ridge lap, or that the open end (tab end) of the shingle be applied away from prevailing winds.
4. **Fasteners.** Fasteners shall be as required by the manufacturer's installation instructions.
5. **Fastener Application.** Shingle manufacturers typically require four fasteners to be applied to each shingle in "standard" or "normal" wind zones, one at each end and over each cut-out. Six fasteners are required in "high" wind zones. HUD Standards, **Section §3280.305** considers Zone I the "standard" wind zone and Zones II and III to be "high" wind zones. Fasteners are to be located above the shingle tabs, and shall not be located in the adhesive strip. In all cases, shingles shall be applied in accordance with the shingle manufacturer's instructions for the appropriate wind zone.
6. **Application of cap shingle (at ridge).** Cap shingles are most often cut out of a single shingle by splitting at the cut-outs (approximately 12" x 12"). Each shingle is bent along the center line of the mating wall ridge so that it extends equally on both sides. Five inches of each shingle will typically be exposed to the weather, with the leading edge away from the prevailing wind. Fasteners shall be placed 5 1/2" back from the leading edge, with one placed on each side of the ridge. Fasteners in the last cap shingle must be sealed.
7. **Ridge Vents.** With the installation of a continuous ridge vent, provisions shall be made for required openings in the roof at the ridge line. Such openings are typically accomplished either by a strip of roof sheathing being cut back on either side of the ridge, or by spaced blocks between the ridge beams or truss top chords. Roofing felt shall not cover the openings. In all cases, installation shall be in accordance with the ridge vent manufacturer's instructions.
8. **Continuous Shingle Support.** Except where ridge vents are located, provisions shall be made to provide continuous support for all shingles.

3.8.5 Exterior Wall Coverings

Multi-section homes commonly require that a portion of the exterior siding be installed at the site. Exterior wall coverings (i.e., hardboard, metal, vinyl siding, etc.) shall be installed in accordance with the siding manufacturer's instructions. If possible, the HUD label should not be removed, covered, damaged, or obscured when applying any exterior covering. If removal of the HUD label is unavoidable, it is recommended that it be reinstalled at the same location on the new exterior covering.

3.8.6 Hinged Roofs and Eaves

Manufactured homes with hinged roofs or eaves should be transported without dismantling of the roof or eave system if possible. If a hinged roof or eave must be dismantled, particular care must be taken that damage does not occur during the dismantling process. When reinstalling dismantled roofs or eaves, all vent stacks, furnaces, water heaters, ventilation systems, fireplaces, and similar items that may have components that penetrate the roof or eave system shall be installed in accordance with the listed appliance manufacturer's instructions. Continuous shingle support shall be provided at all hinged roof locations.

3.8.7 HUD Section §3282.14 Alternative Construction (AC) Procedures

Part 3282, Manufactured Home Procedural and Enforcement Regulations, Section §3282.14, provides for a home manufacturer to request Alternative Construction (AC) approval from HUD. This alternative construction may involve such items as the field completion of roof jack/vent assemblies of gas furnaces, water heaters, and fireplaces that are located in the hinged roof section of multi-section homes.

3.8.7.1 Identification of Alternative Construction Homes

Homes for which Alternative Construction has been approved will have the letters "AC" as part of the home's Serial Number.

3.8.7.2 Completion of Alternative Construction Site Work

All site work shall be accomplished by a licensed contractor or similarly qualified individual selected by the home manufacturer. The contractor shall be provided with plans and installation instructions required to complete the site work which have been approved by the home manufacturer's DAPIA (see **Chapter 2, Definitions**).

3.8.7.3 Inspection of Alternative Construction

All site construction shall be inspected in accordance with the HUD approved Alternate Construction ("AC") letter. Inspection, if required, shall be by the home manufacturer's IPIA (see **Chapter 2, Definitions**) or by a qualified and experienced independent inspector acceptable to the IPIA. Note that this person may be a local inspector. The manufacturer shall provide a HUD-approved Site Inspection Report form to the inspector, who will certify that the installation has been completed in accordance with the DAPIA approved installation instructions. The completed Site Inspection Report form shall then be sent to the home manufacturer, who will in turn provide a copy of the completed form to HUD and distribute copies according to the HUD regulations. All Alternate Construction site work shall be completed and inspected prior to occupancy of the home. A copy of the AC approval letter shall be given to the local inspector when requesting a permit. The IPIA shall provide a copy of the completed AC Site Inspection Report to the local inspector prior to occupancy.

3.8.8 HUD Section §3282.600 On-Site Completion of Construction (SC) of Manufactured Homes

Subpart M - Section §3282.600 of the *Manufactured Home Procedural and Enforcement Regulations*, provides for a home manufacturer to request On-Site Completion of Construction of Manufactured Homes (SC) approval from their Design Approval Primary Inspection Agency (DAPIA) acting on behalf of HUD. This SC construction may involve such items as the on-site completion of hinged roof and eave construction; any work required by the home design that cannot be completed in the factory; site installed appliances; shipped loose components or parts; exterior application such as brick siding, stucco, or tile roof systems; roof extensions (dormers); site installed windows in roofs; removable or open floor sections for basement stairs; and sidewall bay windows.

3.8.8.1 Identification of On-Site completion of Construction of Manufactured Homes

Homes for which On-Site completion of Construction has been approved will have the letters "SC" as part of the home's Serial Number.

3.8.8.2 Completion of On-Site (SC) Construction Procedures Site Work

The manufacturer or a licensed contractor or similarly qualified professional with prior authorization from the manufacturer may perform the on-site work in accordance with the DAPIA approvals and site completion instructions. However, the manufacturer is responsible for the adequacy of all on-site completion work regardless of who does the work, and must prepare and provide all site inspection reports, as well as the certification of completion, and must fulfill all of its responsibilities and maintain all records at the factory of origin as required by §3282.609.

3.8.8.3 Inspection of On-Site completion of Construction.

Prior to occupancy, the manufacturer must ensure that all site construction shall be inspected in accordance with the DAPIA's approved On-Site completion of construction ("SC") letter. Inspection, if required, shall be performed by the home manufacturer's IPIA or by a qualified and experienced independent inspector acceptable to the IPIA. Note that this person may be a local inspector if agreeable. The manufacturer shall prepare a site inspection report upon completion of the work on-site, certifying completion in accordance with §3282.605 - Requirements applicable to completion of construction and that the home conforms with the approved design or, as appropriate under §3282.362(a)(1)(iii), the construction and safety standards. The manufacturer shall also provide this final On-Site Inspection Report and Certification of Completion to the IPIA and, after approval, to the lessor or purchaser and, as applicable, the appropriate retailer, and to the SAA. The manufacturer shall provide a copy of the completed SC On-Site Inspection Report and Certification of Completion to the local inspector prior to occupancy.

3.8.9 Garden and Bay Windows

Manufactured homes (either single or multi-section) supplied with garden or bay windows that require dismantling or removal for transportation purposes shall have these items reinstalled to resist the elements and in strict accordance with the home and/or window manufacturer's installation instructions.

3.8.10 Bottom Board Repair

Penetrations of the bottom board, either as a result of transportation damage or of site-installed construction, shall be repaired to resist moisture and rodent entry. Only approved methods and materials shall be used in such repairs. Areas that commonly require attention include plumbing penetrations, electrical, mechanical, and plumbing crossovers, and marriage line floor connections.

3.9 ANCHORING SYSTEMS

3.9.1 Anchoring Systems -- General Requirements

After the installation of piers per **Section 3.7**, interconnection of units (in the case of multi-section homes) per **Section 3.8**, and leveling in accordance with **Section 3.7.9**, all homes shall be anchored as required for the Wind Zone where the home is located. For USED homes **with a date of manufacture prior to January 1, 2009**, anchoring shall be per **Section 3.9**.

3.9.2 Certification and Capacity of Anchoring Equipment

Each ground anchor must be manufactured and provided with installation instructions in accordance with its listing or certification. A nationally recognized testing agency must list, or a registered professional engineer or registered architect must certify, the ground anchor for use in a classified soil (see **Table 3.9.5**), based on a nationally recognized testing protocol, or a professional engineer or registered architect must certify that the ground anchor is capable of resisting all load as specified in this Section for the soil type or classification. Anchoring equipment, when installed, shall be capable of resisting a minimum ultimate load of 4,725 lbs. and a working load of 3,150 lbs. without failure of either the anchoring equipment or the attachment point on the manufactured home. All products and devices such as ground anchors, frame clamps, crimping devices, etc. for which test data exists, certified by a registered professional engineer or a nationally recognized testing laboratory, documenting the capacity to withstand the loads specified in this Section, shall be acceptable without specific reference to the product or device in this Code.

3.9.3 Anchoring System: Resistance to Weather Deterioration.

Anchoring equipment, including concrete encased anchors, shall have a resistance to weather deterioration at least equivalent to that provided by a coating of zinc on steel of not less than 0.30 ounces per square foot of surface coated.

NOTE: This requirement is still under review by HUD. Do not enforce until further notice.

3.9.4 Tie Strapping Material

All tie strapping material shall be protected in accordance with **Section 3.9.3**. Type 1, Finish B, Grade 1 steel strapping, 1 1/4" wide and 0.035 inches in thickness, conforming to ASTM D 3953 – 97, *Standard Specification for Strapping, Flat Steel, and Seals*, shall be considered to meet the weathering protection requirements of **Section 3.9.3** and the load capacity requirements of **Section 3.9.2**. Slit or cut edges of zinc-coated steel need not be zinc coated.

3.9.5 Ground Anchors

3.9.5.1 Spacing and Installation of Ground Anchors

Spacing of ground anchors shall be in accordance with **Table 3.9.6** for the Wind Zone where the home is located. Anchors shall be installed per **Figures 3.9.6.1, 3.9.6.2, 3.9.6.2.1, 3.9.6.3, or 3.9.6.3.1** as applicable. As an alternate, the entire stabilizing system may be designed and certified by a North Carolina registered engineer or architect who is familiar with the site. The engineer, architect, or his or her representative shall personally inspect the completed installation and shall provide sealed documentation regarding this certification to the local jurisdiction.

NOTE: For NEW homes, if the foundation and anchoring system is not a part of the Manufacturer's Installation Manual or an approved supplement to that manual then the foundation and anchoring system must be designed by a North Carolina Professional Engineer or Registered Architect and approved by the home manufacturer and its DAPIA in order to prevent from taking the home out of compliance with the manufacturer's warranty.

3.9.5.2 Capacity of Anchors

Each ground anchor, when installed, shall be capable of resisting the loads as specified in **Section 3.9.2** without failure. Failure shall be considered to have occurred when the anchor head has been displaced either 2 inches vertically or 3 inches horizontally, whichever occurs first.

3.9.5.3 Selection of Anchors

Anchor selection shall be based on a determination of the soil classification at the depth that the anchor helical plate will be installed. Anchor lengths and model numbers shall be selected in accordance with the anchor manufacturer's requirements for a particular soil classification. *In all cases* anchors should be embedded such that the helical plate is below the frost line and at least 12 inches above the water table. If these conditions cannot be met, the stabilizing system shall be designed and certified by a North Carolina registered engineer or architect.

NOTE: For NEW homes, if the foundation and anchoring system is not a part of the Manufacturer's Installation Manual or an approved supplement to that manual then the foundation and anchoring system must be designed by a North Carolina Professional Engineer or Registered Architect and approved by the home manufacturer and its DAPIA in order to prevent from taking the home out of compliance with the manufacturer's warranty.

3.9.5.3.1 Test Probe

Soil classification for selection of anchors shall be determined by means of a soil probe. The test probe used shall have a 10 3/4” helical section with a major diameter of 1 1/4”, a minor diameter of 13/16” (0.81”), and a pitch of 1 3/4”. The shaft shall be of sufficient length to test the soil at the depth of the anchor helical plate. The probe shall be augured into the ground at the area where the anchors will be installed to the depth of the anchor helix, and a torque wrench reading taken. Based on this reading, the anchor manufacturer’s charts shall be consulted to confirm proper anchor selection. **Table 3.9.5** is an example of such a chart. A record of the torque value obtained by this method *shall be retained by the installer and shall be furnished to the local official if required.*

**TABLE 3.9.5
Soil Classification Chart**

| Soil Class | Soil Description | Test Probe Value (in. – lbs.) | Recommended Anchor |
|-------------------|--|--------------------------------------|---------------------------|
| 1 | Rock or hard pan | N/A | Rock Anchor |
| 2 | Sandy gravel and gravel; very dense and/or cemented sands; coarse gravel/cobbles; preloaded silts, clays and coral | More than 550 | Per Anchor Mfr. |
| 3 | Sand; silty sand; clayey sand; silty gravel; medium dense course sands; sandy gravel; very stiff silts and clays | 351–550 | Per Anchor Mfr. |
| 4A | Loose to medium dense sands; firm to stiff clays and silts; alluvial fills | 276–350 | Per Anchor Mfr. |
| 4B | Loose sands; firm clays; alluvial fills | 175–275* | Per Anchor Mfr. |

* Below these values, a North Carolina registered engineer or architect shall be consulted.

3.9.5.4 Anchor Identification.

Each ground anchor shall have the manufacturer’s identification and tested model identification number permanently marked in a location such that the number is visible after installation. Instructions shall accompany each listed ground anchor specifying the types of soil for which the anchor is suitable under the requirements of **Section 3.9.5.3**.

3.9.6 Anchoring System Installation

3.9.6.1 Ground Anchor Design and Installation.

Each manufactured ground anchor shall be tested and installed in accordance with the terms of its testing and the anchor manufacturer’s instructions. The anchor manufacturer’s instructions shall include the means of attachment of ties, the amount of preload required, the methods of adjustment after installation, and the load capacity in various types of soils.

3.9.6.2 Ground Anchors Loaded in Direct Withdrawal

For anchors attached to a single strap, either diagonal or vertical, the anchor shall be considered to be loaded in direct withdrawal when the shaft of the anchor is parallel to the strap to within plus or minus 15 degrees. For anchors attached to two straps (i.e. diagonal and vertical), the anchor shall be considered to be loaded in direct withdrawal when the shaft of the anchor is aligned midway between the angle formed by the two straps. **See Figure 3.9.6.1**

3.9.6.3 Ground Anchors Loaded in Other Than Direct Withdrawal

For ground anchors not loaded in direct withdrawal as defined in **Section 3.9.6.2**, provision shall be made to minimize the deflection or slicing through the soil by the anchor shaft at ground level. The restriction of lateral deflection shall be accomplished by the installation of listed devices such as stabilizer plates obtained from the anchor supplier and installed in strict conformance with the anchor manufacturer’s instructions, or the encasement of the top portion of the anchor in a 10 inch diameter x 18 inch deep cylinder of concrete or equivalent. Alternate methods shall be approved by a North Carolina registered engineer or architect.

NOTE: For NEW homes, if the foundation and anchoring system is not a part of the Manufacturer’s Installation Manual or an approved supplement to that manual then the foundation and anchoring system must be designed by a North Carolina Professional Engineer or Registered Architect and approved by the home manufacturer and its DAPIA in order to prevent from taking the home out of compliance with the manufacturer’s warranty.

See Figure 3.9.6.1

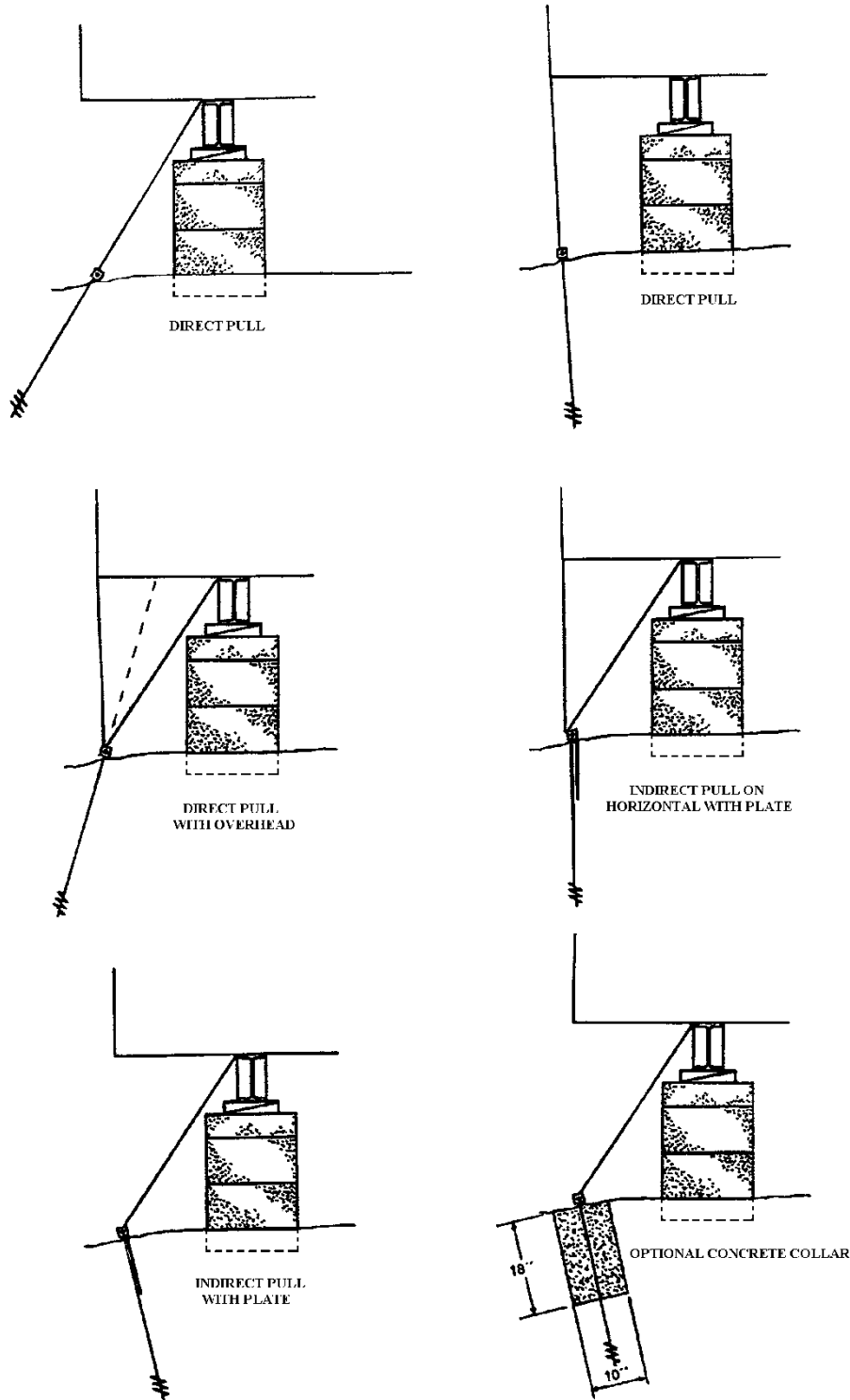

FIGURE 3.9.6.1
Examples of Approved Methods of Ground Anchor Installation

3.9.6.4 Anchors Embedded in Concrete

Anchors designed for embedment in concrete may be used in lieu of ground anchors. However, sufficient concrete must be placed in a single pour at each anchor location such that the anchor is capable of resisting a load of 4725 pounds in the direction of the tie without displacement of either the anchor or surrounding concrete.

3.9.6.5 Rock Anchors

Rock anchors are approved for use where substantial masses of solid rock or bedrock are encountered such that augured ground anchors cannot be installed to the proper depth. Rock anchors are NOT intended where site conditions are simply “rocky soil”, such that installation of augured ground anchors is difficult. Where such rocky soil conditions prevent the proper installation of ground anchors, a North Carolina registered engineer or architect shall be consulted for design of the entire stabilizing system. If, during the recommended inspection (see **Section 3.3.1**) of the site prior to arrival of the home, the installer determines that rocky soil conditions exist such that the services of a registered engineer or architect are required, the responsibility for securing and paying for these services shall rest with the homeowner unless otherwise agreed to by contract. If the installer has failed to inspect the site prior to the arrival of the home and it is determined that such services are required, the responsibility for securing and paying for these services shall rest with the installer.

3.9.6.6 Attachment of Tie Straps

3.9.6.6.1 Strap Protection Requirements

Where a tie strap passes through a bracket and doubles back on itself (such as at the attachment of vertical ties, longitudinal ties, or attachment of diagonal ties to a listed clamping device), protection shall be provided at the sharp corners of the bracket to prevent damage to the strap. Some brackets and clamping devices are manufactured with rounded corners where the strap passes through, and no further protection is required. Where special rounded corners are not provided, a protective clip may be fabricated using a 3” length of tie strap material that is manually bent into a “U” shape. The “U” shaped clip is then inserted in the slot of the bracket, with the tie strap passing over top of the clip.

3.9.6.6.2 Diagonal Tie Straps

Diagonal tie straps shall connect the ground anchor and the main structural steel frame (I-beam or other shape) which runs lengthwise under the home. Tie straps shall not connect to steel outrigger beams which fasten to and intersect the main structural frame unless specifically stated in the manufacturer’s installation instructions. Attachment of the tie strap to the anchor shall be in strict compliance with the anchor manufacturer’s instructions. Buckles, listed clamping devices, etc. used for attachment of the tie strap to the I-beam shall be installed in strict compliance with the anchor manufacturer’s instructions. Tie-down straps shall connect the anchor to the TOP of the “I” beam unless the *home manufacturer’s instructions* specifically indicate otherwise. If the home manufacturer permits connection to the bottom of the I-beam, the anchor manufacturer must provide an approved method for making this connection. Diagonal tie straps shall not be spliced.

3.9.6.6.3 Vertical Tie Straps

For all USED homes **with a date of manufacture prior to January 1, 2009**, single section homes in any Wind Zone and multi-section homes in Wind Zones II and III shall have all factory installed permanently attached vertical straps attached to an anchor. All such homes which do not have permanently attached vertical straps but have factory installed provisions for the attachment of vertical straps, such as brackets attached to the side of the home, shall have vertical straps connecting the bracket to an anchor. When brackets attached to the side wall are present, the underside of the home, including the I-beams, shall be carefully inspected to determine if additional brackets are present indicating a shear wall location. All such brackets shall have straps connecting the bracket to an anchor immediately below. Attachment to the bracket(s) shall be in accordance with the anchor manufacturer’s instructions. A factory installed permanently attached strap which has been cut off may be spliced once, provided a listed splicing device is used. A vertical and diagonal tie strap may connect to the same anchor, provided the anchor is designed to receive two straps.

3.9.6.6.4 Over-the-Roof Ties for Older Homes

Older models of single section homes sometimes utilized over-the-roof ties. In the absence of the Manufacturer’s Installation Instructions the roof and/or siding should be carefully inspected to determine if stains or other markings are present indicating where straps were previously located. All such locations shall have over-the-roof ties connected to an anchor on each side of the home. Single section homes in Wind Zone I that utilize over-the-roof ties shall have a minimum of two such ties per side. For single section homes in Wind Zones II and III, a North Carolina registered engineer or architect shall be consulted to determine the number of over-the-roof ties that are to be installed. All such ties shall be positioned at rafters and studs. Over-the-roof ties shall not be used on homes with “A” line or shingled roofs. Provision shall be made at sharp corners to protect both the straps and to minimize damage to roofing or siding by the straps. Anchors for use with over-the-roof straps shall fully comply with the requirements of **Section 3.9** of this Code. The attachment of over-the-roof ties to an anchor shall be in accordance with the anchor manufacturer’s instructions. Over-the-roof straps, when utilized, are to be IN ADDITION to required diagonal straps, which shall be located in accordance with **Table 3.9.6**.

3.9.6.6.5 Longitudinal Tie Straps

All USED homes (both single and multi-section) **with a date of manufacture prior to January 1, 2009**, shall have longitudinal ties installed in accordance with the schedule given below. Tie straps shall be connected to brackets welded to the underside of the main I-beams or to listed clamping devices designed to receive longitudinal ties. The attachment to the bracket or clamping device shall be in accordance with the anchor manufacturer’s instructions, and the tie strap shall be installed at an angle of not greater than 45 degrees, measured from the horizontal. Anchors for use with longitudinal ties shall fully comply with the requirements of Section 3.9 of this Code. Longitudinal tie straps shall not be spliced.

Single Section Homes:

| <u>Wind Zone</u> | <u>Number of Longitudinal Ties at Each End of Home</u> |
|------------------|--|
| I, II, & III | 2 |

Double Section Homes:

| <u>Wind Zone</u> | <u>Number of Longitudinal Ties at Each End of Home</u> |
|------------------|---|
| I | 2 (attach either to two innermost I-beams or two outermost I-beams) |
| II & III | 4 (attach to each I-beam of each section at each end) |

Note: For triple section homes or homes with tag units, add 2 longitudinal ties at each end of third section or tag unit.

3.9.7 Maintaining Anchoring Systems

Tie strap tension should be checked and adjusted annually when necessary to prevent damage to the manufactured home due to settling or other unforeseen movements (such as frost heave). The responsibility for monitoring tie strap tension shall rest with the homeowner.

3.9.8 Permanency Of Connections

Anchoring equipment shall be designed to prevent self-disconnection when tie straps are slack. Such design shall be the responsibility of the anchoring equipment manufacturer.

3.9.9 Special Ties

Clerestory roofs and add-on sections of expandable manufactured homes shall have provisions for vertical ties at the exposed ends.

3.9.10 Alternate Anchoring Methods

For USED homes, alternate anchoring devices or anchoring systems meeting the requirements of **Section 3.9** shall be permitted. For NEW homes, alternate anchoring devices or anchoring systems meeting the requirements of **Section 3.9** shall be permitted if approved by the home manufacturer.

TABLE 3.9.6

Diagonal Tie Strap Spacing

| Required Strap Angle (from horizontal) | MAXIMUM ANCHOR SPACING | | |
|---|------------------------|--------------|---------------|
| | Wind Zone I | Wind Zone II | Wind Zone III |
| 40° to 50° | 11'-0" | 6'-0" | 4'-6" |

NOTES to Table 3.9.6

1. Vertical tie straps are to be in accordance with **Sections 3.9.6.6.2** and **3.9.6.6.3**.
2. Longitudinal tie straps are to be in accordance with **Section 3.9.6.6.5**.
3. Maximum distance to first diagonal tie strap from either end of the home is 2'-0".
4. Minimum pier heights shall be such as to meet the requirements of **Section 3.7.2**.
5. Subject to the limitations of **Section 3.7.6** (main I-beam support piers more than 67" in height, measured from the grade line to the top of the cap block) and **Section 3.7.7** (more than one-fourth of the main I-beam support piers greater than 36" in height, measured from the grade line to the top of the cap block), when pier heights are such that the required strap angle cannot be obtained, the criss-cross method as described in **Figures 3.9.6.2** and **3.9.6.3** may be used. NOTE: If the footing is installed on top of the ground as permitted in **Section 3.5.2**, **EXCEPTION**, the pier height shall be measured from the TOP OF THE FOOTING TO THE TOP OF THE CAP BLOCK.
6. Tie strap spacing shall be as even as practical along the length of the home. Strap spacings may exceed the values in this Table by up to 10% so long as the average spacing does not exceed the Table values.

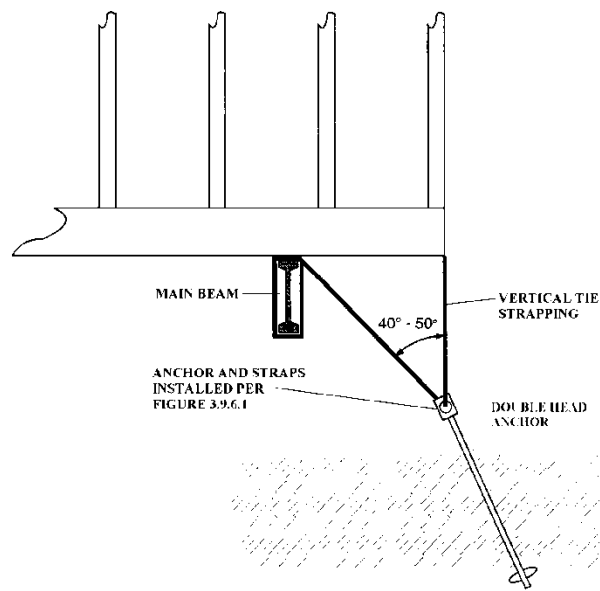
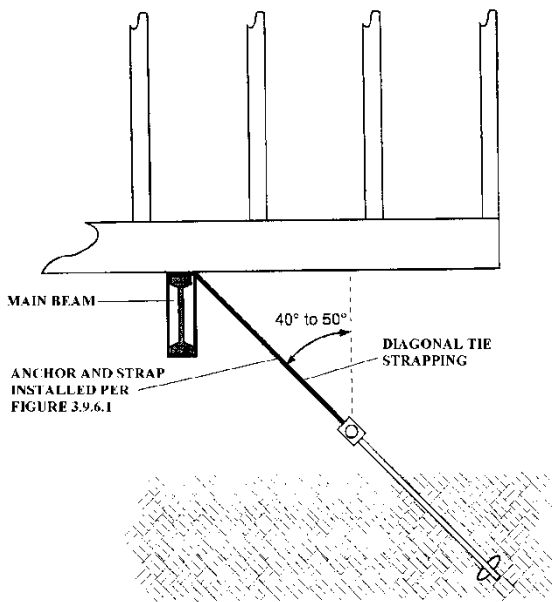

ALIGNMENT OF STRAPS AND ANCHORS

FIGURE 3.9.6.2

Criss-Cross Strapping System for Single Section Homes

(for use when required strap angle in Table 3.9.6 cannot be obtained)

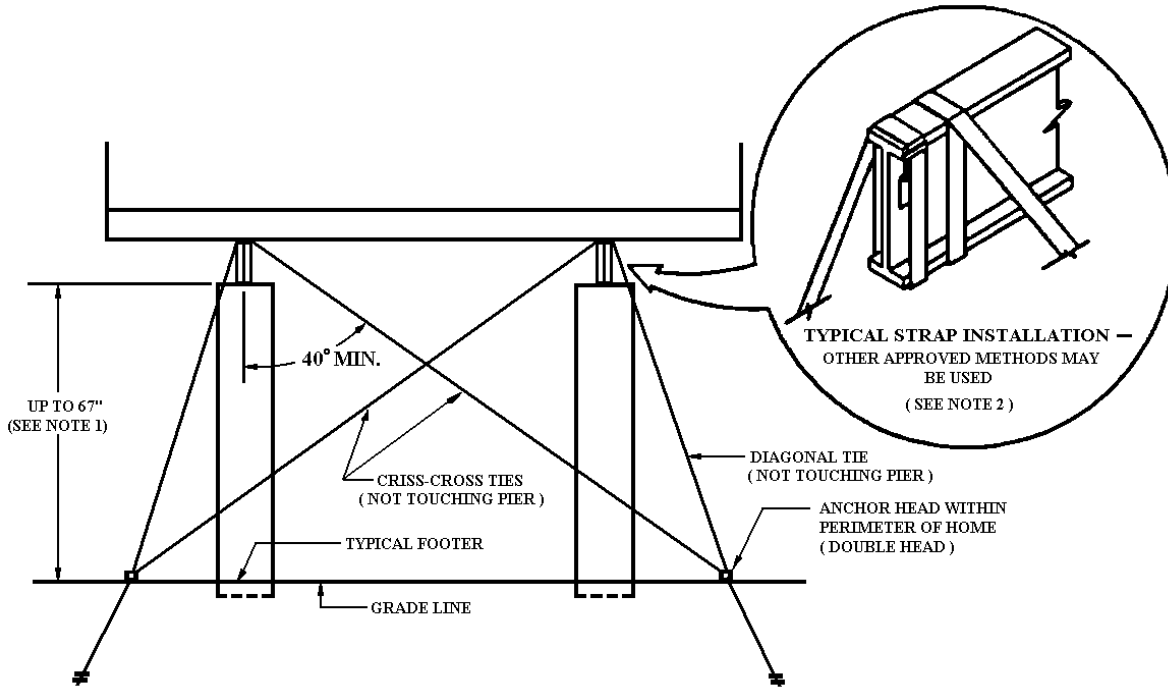

NOTES to Figure 3.9.6.2

1. Pier height is measured from the grade line to the top of the cap block, except as permitted in **Section 3.5.2**. **EXCEPTION.** The criss-cross method is NOT to be used where pier height exceeds 67" or where more than one-fourth of the main I-beam support piers have heights greater than 36". (See **Sections 3.7.6** and **3.7.7**)
2. Straps shall not be looped and continue under the home. Inset drawing shows typical strap installation. All anchors, devices, and straps used in the criss-cross method shall fully comply with the provisions of **Section 3.9**.
3. When the criss-cross method is used, either in a single location or in multiple locations, the maximum spacing to adjacent anchors on either side shall be as given in **Table 3.9.6**.
4. When the required strap angle in **Table 3.9.6** can be obtained on one side of the home but not the other, the criss-cross method may be applied only on the side where the angle cannot be met (see **Figure 3.9.6.2.1**). In all cases, the straps that attach to the near side I-beam shall be installed.
5. If the criss-cross method is used at the ends of the home, the maximum distance to the tie strap from the end of the home shall be 2'-0".
6. The illustrations in **Figures 3.9.6.2** and **3.9.6.2.1** show a direct pull orientation. For anchors in other than direct withdrawal, see **Section 3.9.6.3**.

FIGURE 3.9.6.2.1

Criss-Cross from One Side Only

(See Note 4 to Figure 3.9.6.2 above)

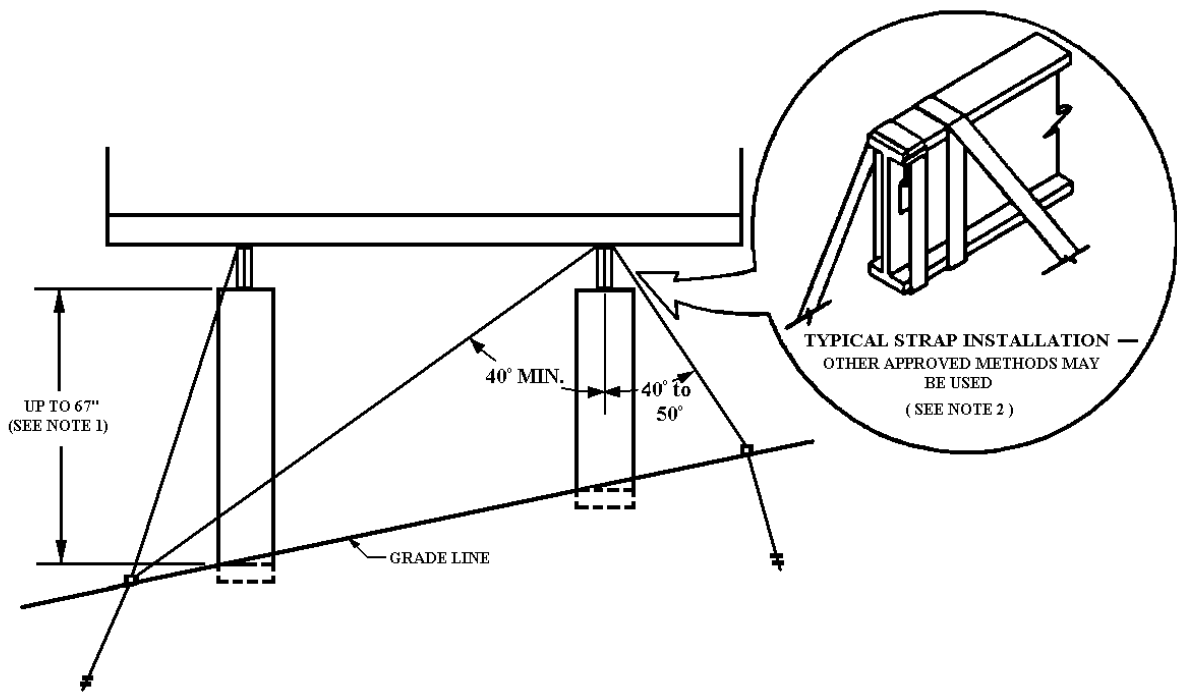
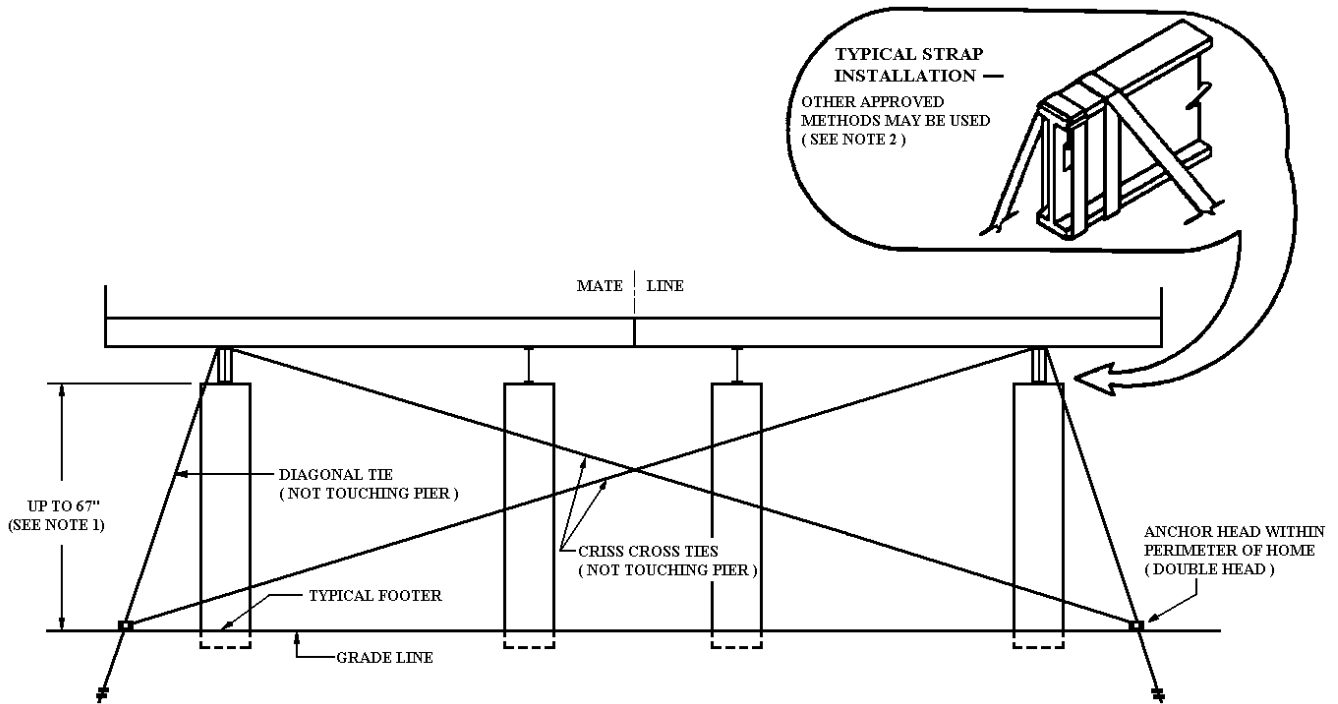

FIGURE 3.9.6.3

Criss-Cross Strapping System for Multi-Section Homes

(for use when required strap angle in Table 3.9.6 cannot be obtained)



NOTE: Criss-cross ties may be installed as shown below so long as the 40 degree minimum angle indicated is maintained.

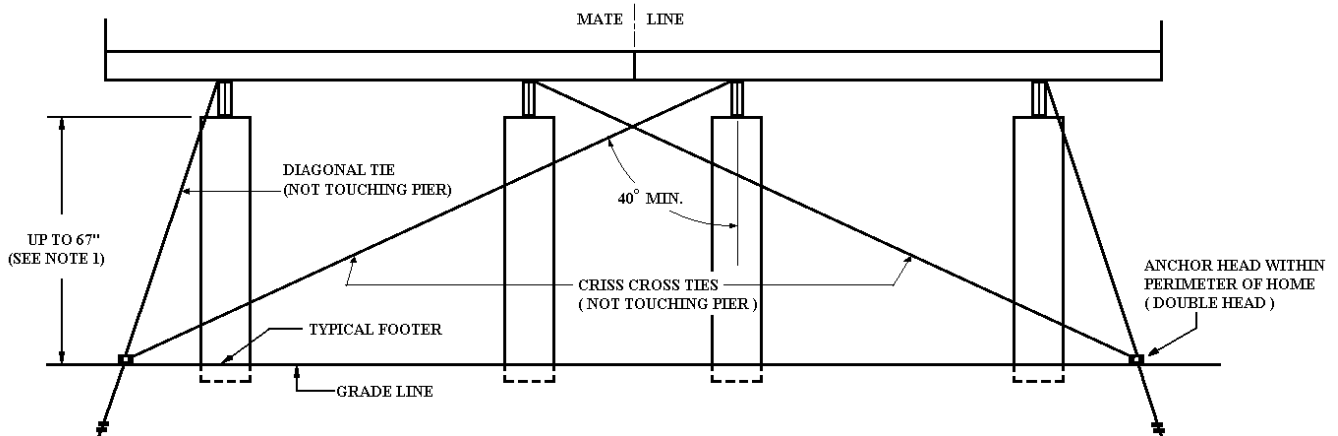

NOTES to Figure 3.9.6.3

1. Pier height is measured from the grade line to the top of the cap block, except as permitted in **Section 3.5.2. EXCEPTION**. The criss-cross method is NOT to be used where pier height exceeds 67" or where more than one-fourth of the main I-beam support piers have heights greater than 36". (See **Sections 3.7.6** and **3.7.7**)
2. Straps shall not be looped and continue under the home. Inset drawing shows typical strap installation. All anchors, devices, and straps used in the criss-cross method shall fully comply with the provisions of **Section 3.9**.
3. When the criss-cross method is used, either in a single location or in multiple locations, the maximum spacing to adjacent anchors on either side shall be as given in **Table 3.9.6**.
4. When the required strap angle in **Table 3.9.6** can be obtained on one side of the home but not the other, the criss-cross method may be applied only on the side where the angle cannot be met (see **Figure 3.9.6.3.1**). In all cases, the straps that attach to the near side I-beam shall be installed.
5. If the criss-cross method is used at the ends of the home, the maximum distance to the tie strap from the end of the home shall be 2'-0".
6. The illustrations in **Figures 3.9.6.3** and **3.9.6.3.1** show a direct pull orientation. For anchors in other than direct withdrawal, see **Section 3.9.6.3**.

FIGURE 3.9.6.3.1

Criss-Cross from One Side Only

(See Note 4 to Figure 3.9.6.3 above)

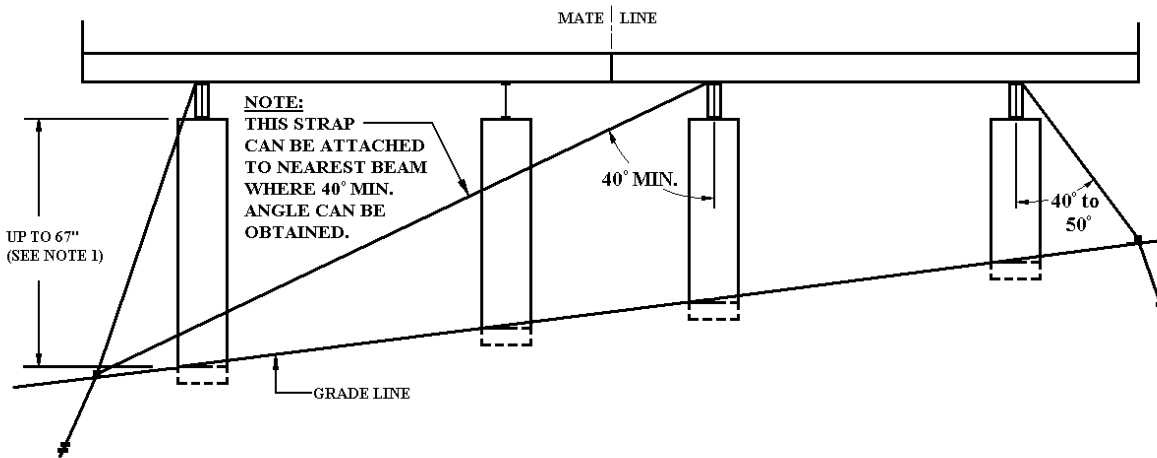

3.10 CRAWLSPACE ENCLOSURES

3.10.1 Ventilation Of Skirted Homes

Skirting or curtain wall construction is optional for manufactured homes unless required by local ordinance. However, if a skirting or curtain wall system is installed, ventilation for the crawl space shall be provided in accordance with this Section.

3.10.2 Means of Providing Ventilation

Required ventilation shall be provided by ventilated skirting panels, openings in the masonry that are covered with corrosion resistant wire mesh with the least dimension being 1/8", cast iron grills or grating, or equivalent means. *One such ventilation opening shall be placed within 3 feet of each corner of the building*, and the remaining openings shall be oriented around the perimeter of the home so as to provide cross-ventilation of the space. Louvers type vents are permitted, but shall be located and installed so as to be fully operable.

3.10.3 Required Vapor Barrier

In order to prevent moisture damage to the home, a 6 mil polyethylene vapor retarder or equivalent shall be installed over the complete area under the home, with joints overlapping at least 12 inches. The vapor retarder may be cut to fit around piers, and may be placed directly beneath, around, or over footings installed on top of the ground (see **Section 3.5.2**), and around anchors or other obstructions. The vapor barrier shall be placed by the installer.

3.10.4 Required Ventilation Opening Area

Ventilation shall be provided having not less than one (1) square foot of net free opening for each fifteen hundred (1500) square feet of crawl space. See **Table 3.10.4** (page 59) for determination of required area when a vapor retarder is installed. The vapor retarder shall be placed by the installer.

TABLE 3.10.4

CRAWLSPACE VENTILATION

Homes WITH a Vapor Barrier

Required Net Free Ventilation Area (square inches): $V = L \times W \times 144 / 1500$

| LENGTH (feet) | WIDTH OF MANUFACTURED HOME (feet) | | | | | | | | | | | | | | | | | | | | |
|------------------|-----------------------------------|----|----|-----|-----|-----|-----|-----|-----|-----|-----|-----|-----|-----|-----|-----|-----|-----|-----|-----|-----|
| | 8 | 10 | 12 | 14 | 16 | 18 | 20 | 22 | 24 | 26 | 28 | 30 | 32 | 34 | 36 | 38 | 40 | 42 | 44 | 46 | 48 |
| 40 | 31 | 38 | 46 | 54 | 61 | 69 | 77 | 84 | 92 | 100 | 108 | 115 | 123 | 131 | 138 | 146 | 154 | 161 | 169 | 177 | 184 |
| 42 | 32 | 40 | 48 | 56 | 65 | 73 | 81 | 89 | 97 | 105 | 113 | 121 | 129 | 137 | 145 | 153 | 161 | 169 | 177 | 185 | 194 |
| 44 | 34 | 42 | 51 | 59 | 68 | 76 | 84 | 93 | 101 | 110 | 118 | 127 | 135 | 144 | 152 | 161 | 169 | 177 | 186 | 194 | 203 |
| 46 | 35 | 44 | 53 | 62 | 71 | 79 | 88 | 97 | 106 | 115 | 124 | 132 | 141 | 150 | 159 | 168 | 177 | 185 | 194 | 203 | 212 |
| 48 | 37 | 46 | 55 | 65 | 74 | 83 | 92 | 101 | 111 | 120 | 129 | 138 | 147 | 157 | 166 | 175 | 184 | 194 | 203 | 212 | 221 |
| 50 | 38 | 48 | 58 | 67 | 77 | 86 | 96 | 106 | 115 | 125 | 134 | 144 | 154 | 163 | 173 | 182 | 192 | 202 | 211 | 221 | 230 |
| 52 | 40 | 50 | 60 | 70 | 80 | 90 | 100 | 110 | 120 | 130 | 140 | 150 | 160 | 170 | 180 | 190 | 200 | 210 | 220 | 230 | 240 |
| 54 | 41 | 52 | 62 | 73 | 83 | 93 | 104 | 114 | 124 | 135 | 145 | 156 | 166 | 176 | 187 | 197 | 207 | 218 | 228 | 238 | 249 |
| 56 | 43 | 54 | 65 | 75 | 86 | 97 | 108 | 118 | 129 | 140 | 151 | 161 | 172 | 183 | 194 | 204 | 215 | 226 | 237 | 247 | 258 |
| 58 | 45 | 56 | 67 | 78 | 89 | 100 | 111 | 122 | 134 | 145 | 156 | 167 | 178 | 189 | 200 | 212 | 223 | 234 | 245 | 256 | 267 |
| 60 | 46 | 58 | 69 | 81 | 92 | 104 | 115 | 127 | 138 | 150 | 161 | 173 | 184 | 196 | 207 | 219 | 230 | 242 | 253 | 265 | 276 |
| 62 | 48 | 60 | 71 | 83 | 95 | 107 | 119 | 131 | 143 | 155 | 167 | 179 | 190 | 202 | 214 | 226 | 238 | 250 | 262 | 274 | 286 |
| 64 | 49 | 61 | 74 | 86 | 98 | 111 | 123 | 135 | 147 | 160 | 172 | 184 | 197 | 209 | 221 | 233 | 246 | 258 | 270 | 283 | 295 |
| 66 | 51 | 63 | 76 | 89 | 101 | 114 | 127 | 139 | 152 | 165 | 177 | 190 | 203 | 215 | 228 | 241 | 253 | 266 | 279 | 291 | 304 |
| 68 | 52 | 65 | 78 | 91 | 104 | 118 | 131 | 144 | 157 | 170 | 183 | 196 | 209 | 222 | 235 | 248 | 261 | 274 | 287 | 300 | 313 |
| 70 | 54 | 67 | 81 | 94 | 108 | 121 | 134 | 148 | 161 | 175 | 188 | 202 | 215 | 228 | 242 | 255 | 269 | 282 | 296 | 309 | 323 |
| 72 | 55 | 69 | 83 | 97 | 111 | 124 | 138 | 152 | 166 | 180 | 194 | 207 | 221 | 235 | 249 | 263 | 276 | 290 | 304 | 318 | 332 |
| 74 | 57 | 71 | 85 | 99 | 114 | 128 | 142 | 156 | 170 | 185 | 199 | 213 | 227 | 242 | 256 | 270 | 284 | 298 | 313 | 327 | 341 |
| 76 | 58 | 73 | 88 | 102 | 117 | 131 | 146 | 161 | 175 | 190 | 204 | 219 | 233 | 248 | 263 | 277 | 292 | 306 | 321 | 336 | 350 |

NOTES TO Table 3.10.4:

1. This Table indicates the total area in square inches required for crawlspace ventilation when the underfloor area is enclosed by skirting or masonry construction.
2. To determine the required amount of net free ventilation area, find the appropriate width of the home across the top line of the Table and then find the length of the home down left side of the Table. The required net free area of ventilation in square inches will be indicated where the appropriate row and column intersect.
3. The number of vents or ventilated skirting panels is determined by dividing the value found in the appropriate Table by the net free area provided by one vent or ventilated panel. Round up to the next whole number (see Examples below). Regardless of the number obtained by this method, the minimum number of vents or ventilated panels is four (4), with one vent or panel located within 3 ft. of each corner of the building (see **Section 3.10.2**). Remaining vents or panels shall be distributed evenly around the perimeter of the home to provide cross-ventilation.

EXAMPLES FOR USE OF TABLE 3.10.4

EXAMPLE 1

How many 8" x 16" foundation vents are required to vent the enclosed crawlspace for a 28' x 56' home? The home has the required vapor barrier covering the crawlspace. Each vent provides 51.2 square inches of net free ventilation area.

Step 1 – Determine the total amount of net free ventilation area required.

Table 3.10.4 is used to determine the total net free ventilation area required. In the table find the width of the home (28 feet) across the top of the table and then find length of the home (56 feet) down the left side of the table. The intersection of this column and row indicates the total net free ventilation area required for the home (151 square inches).

Step 2 – Determine the number of 8" x 16" foundation vents required to vent this home.

It was stated that each vent provides 51.2 square inches of net free ventilation area (note that this information is usually stamped onto the back of the foundation vents, or can be found in the vent manufacturer's installation instructions). To determine the total number of foundation vents needed, divide the Required Net Free Ventilation Area (determined in **Step 1**) by the Net Free Vent Area provided by each foundation vent. $151 \text{ sq. in.} / 51.2 \text{ sq. in. per vent} = 2.9 \text{ vents}$.

Rounding up to the next whole number gives a total of 3 vents required. However, **Section 3.10.2** requires one vent to be placed within 3 feet of each corner of the home. Therefore, *a total of 4 vents will be required, to be placed within 3 feet of each corner of the home.*

EXAMPLE 2

How many linear feet of ventilated skirting panel are required to vent an enclosed crawlspace for a 28' x 76' home? The crawlspace will be covered with the required 6 mil vapor barrier. Each linear foot of ventilated skirting panel provides 5.01 square inches of net free ventilation area.

Step 1

Table 3.10.4 is used to determine the total net free ventilation area required. In the table find the width of the home (28 feet) across the top of the table and then find the length of the home (76 feet) down the left side of the table. The intersection of this column and row indicates the total net free ventilation area required for the home (204 square inches).

Step 2

It was stated that each linear foot of ventilated skirting panel provides 5.01 square inches of net free ventilation area (note that this information is usually stamped onto the back of the ventilated skirting panels, or can be found in the skirting manufacturer's installation instructions). To determine the total linear feet of ventilated skirting panel needed, divide the Required Net Free Ventilation Area (determined in **Step 1**) by the Net Free Vent Area per Linear Foot provided by each ventilated panel. $204 \text{ sq. in.} / 5.01 \text{ sq. in. per linear foot of panel} = 40.7 \text{ linear feet of ventilated skirting panel}$. Rounding up to the next whole number, a total of 41 linear feet of ventilated panel will be required. If the panels come in 12 foot sections, a total of $41 / 12 = 3.4$, say 3 1/2 panels must be used. In accordance with **Section 3.10.2**, a ventilated panel must be installed within 3 feet of each corner of the home, with the remainder being distributed evenly around the perimeter of the home. The 12 foot sections will be cut to the required length, depending on the height of the perimeter of the home above the grade line. This will determine the actual *number* of cut sections installed, with the combined length of all sections being at least 41 feet. At least one such section must be placed within 3 feet of each corner of the home in order to comply with **Section 3.10.2**.

3.10.5 Termination of Exhaust Air Vents and Condensate Drains

Exhaust air vents and condensate drains from any appliance or fixture shall not terminate in the crawl space of a manufactured dwelling or into any attached garage or other structure.

3.10.6 Source of Intake or Combustion Air

Intake air for any appliance or fixture which provides ventilation to the inside of the manufactured home may not be drawn from the crawl space or from any attached garage or other structure. However, combustion air for an appliance may be drawn from the crawl space when this is permitted by the listed appliance manufacturer's installation instructions.

3.11 EGRESS REQUIREMENTS

3.11.1 Egress -- General Requirements

Federal regulations require that each manufactured home have a minimum of two exterior egress doors that are located remotely from each other. Where any means of egress from a manufactured home, including sliding glass doors, is not substantially level with grade, such differences in elevation shall be negotiated by stairs or ramps which are constructed in accordance with **Sections 3.11.2 and 3.11.3**. Landings shall comply with **Section 3.11.4**. Egress stairs, ramps, and landings shall be provided and installed by the selling party unless specifically contracted otherwise by the homeowner. Material for stairs, ramps, and landings constructed of wood shall be pressure-treated in accordance with **AWPA U1-07, Use Category System: User Specification for Treated Wood**.

3.11.2 Exterior Steps and Stairways

3.11.2.1 General

All stairs and landings constructed in accordance with this Code shall be entirely self-supporting unless designed and approved by a registered North Carolina Engineer or Architect. *Adequate bracing of stairway and landing structures shall be provided as required for lateral stability.*

3.11.2.2 Footings for Stairway and Landing Structures

All support posts for exterior stairway and landing structures shall rest on a minimum 8" x 16" x 4" thick concrete masonry or 8" x 16" x 6" thick poured in place concrete footing. The bottom of such footings shall be below the frost line or a minimum of 4" below grade, whichever is greater.

EXCEPTION: Stair or landing structures that are designed by a North Carolina registered engineer specifically to be set directly on the ground do not require footings as described above.

3.11.2.3 Width

Stairways shall not be less than 36 inches in clear width. The minimum width at and below the handrail height shall not be less than 32 inches where a handrail is installed on one side and 28 inches where handrails are provided on both sides.

3.11.2.4 Stair treads and risers

3.11.2.4.1 Risers

The maximum riser height shall be 8-1/4 inches. The riser shall be measured vertically between leading edges of the adjacent treads. The greatest riser height within any flight of stairs shall not exceed the smallest by more than 3/8 inch. Where the bottom riser of an exterior stair adjoins an exterior walk, porch, driveway, patio, garage floor, or finish grade, the height of the riser may be less than the height of the adjacent risers. The height from the top tread or top of a landing (when a landing is present) to the door threshold shall not exceed 8-1/4". **See Figure 3.11.**

3.11.2.4.2 Treads

The minimum tread depth shall be 9 inches. The tread depth shall be measured horizontally between the vertical planes of the foremost projection of adjacent treads and at a right angle to the tread's leading edge. The greatest tread depth within any flight of stairs shall not exceed the smallest by more than 3/8 inch. The walking surface of treads and landings of a stairway shall be sloped no steeper than one inch vertical in 48 inches horizontal (2-percent slope). **See Figure 3.11.**

3.11.2.5 Profile

The radius of curvature at the leading edge of the tread (nosing) shall be no greater than 9/16 inch. A nosing not less than 3/4 inch but not more than 1-1/4 inches shall be provided on stairways with solid risers. The greatest nosing projection shall not exceed the smallest nosing projection by more than 3/8 inch. Beveling of nosing shall not exceed 1/2 inch. Risers shall be vertical or sloped from the underside of the leading edge of the tread above at an angle not more than 30 degrees from the vertical. Open risers are permitted, provided that the opening between treads does not permit the passage of a 4 inch diameter sphere.

Exceptions:

1. A nosing is not required where the tread depth is a minimum of 11 inches.
2. The opening between adjacent treads is not limited on stairs with a total rise of 30 inches or less.

3.11.2.6 Handrails

Handrails shall be provided on all open sides of stairways of four or more risers (when the elevation of the top of the uppermost riser is more than 30" above floor or grade below). Handrail height, measured vertically from the sloped plane adjoining the tread nosing, shall be not less than 34" and not more than 38". All required handrails shall be continuous the full length of the stairs. Ends shall be returned or shall terminate in newel posts or safety terminals. **See Figure 3.11.**

3.11.2.7 Handrail grip size

The handgrip portion of the handrails shall not be more than 3-1/2 inches in cross-sectional dimension, or the shape shall provide an equivalent gripping surface. The handgrip portion of handrails shall have a smooth surface with no sharp corners.

3.11.2.8 Guardrails

Guardrails shall be located at open-sided walking surfaces, including stairs, ramps and landings, that are located more than 30" measured vertically to the grade below at any point within 36" horizontally to the edge of the open side. Such guardrails shall be not less than 36 inches in height measured vertically above the adjacent walking surface.

3.11.2.9 Guardrail and handrail opening limitations

Required guardrails shall not have openings from the walking surface to the required guardrail height which allow passage of a sphere 4" in diameter. **See Figure 3.11.**

Exceptions:

1. The triangular openings at the open side of a stair, formed by the riser, tread and bottom rail of a guard, shall not allow passage of a sphere 6" in diameter. **See Figure 3.11.**
2. Guards on the open sides of a stair shall not have openings which allow passage of a sphere 4-3/8" in diameter. **See Figure 3.11.**

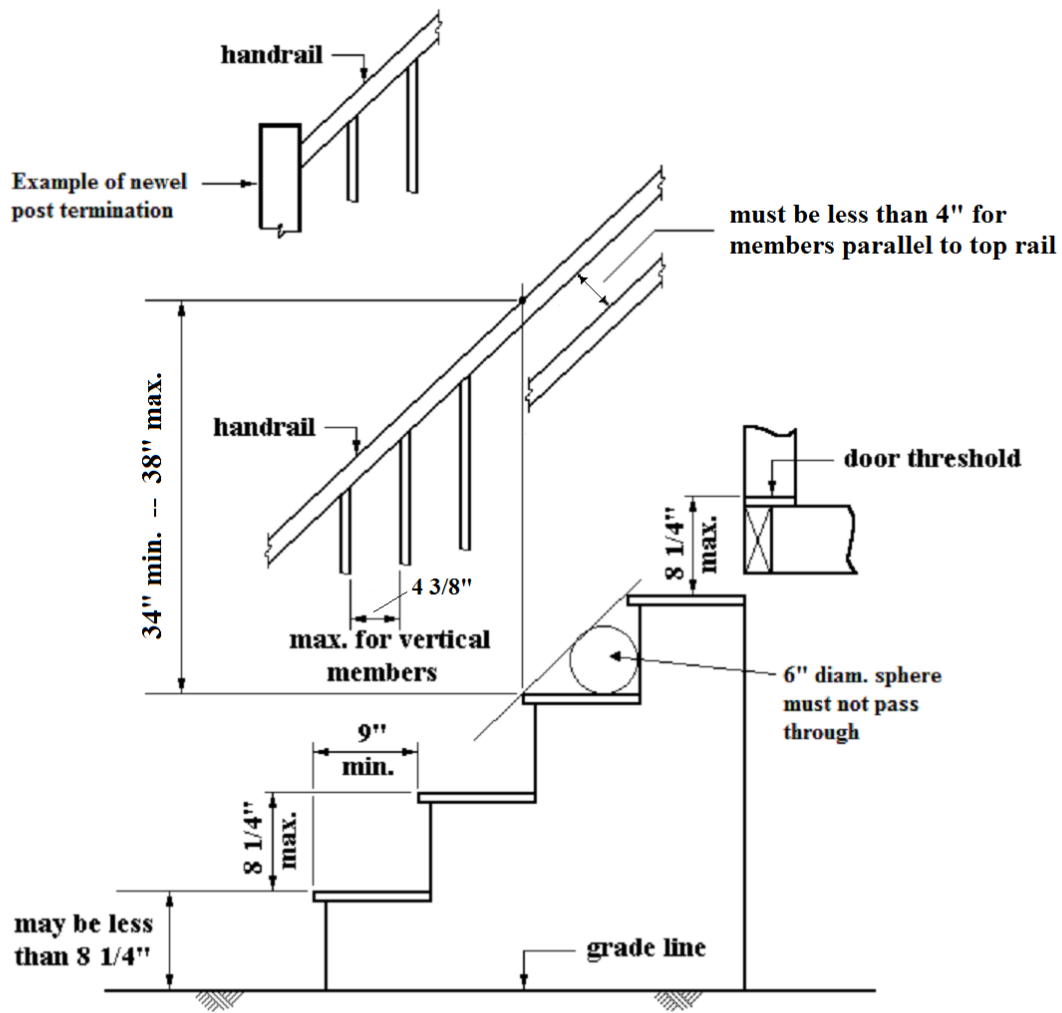

FIGURE 3.11
Stair and Rail Geometry

3.11.2.10 Structural Requirements

Guardrails and handrails shall be capable of withstanding a single concentrated load of 200 lbs. applied in any direction at any point along the top. Material for stairs and landings constructed of wood shall be No. 2 or better treated Southern Pine or equivalent (see 3.11.1). The minimum thickness of stair treads and decking for landings shall be as follows:

| Support Spacing | Tread or Decking (nominal) |
|-----------------|----------------------------|
| 12" o.c. | 1" S4S |
| 16" o.c. | 1" T & G |
| 24" o.c. | 1-1/4" S4S |
| 32" o.c. | 2" S4S |

As an alternate, an engineered design certified by a North Carolina Registered Engineer or Architect may be provided. In this design the stair tread or floor deck shall be capable of supporting either a uniformly distributed live load of 40 psf or a 300 lb. concentrated load acting over an area of 4 square inches, whichever produces the greater stresses. Maximum allowable deflection under these loads shall be $L/240$. Notched stair stringers shall have a minimum effective depth at each notch of not less than 3 1/2 inches unless an alternate design certified by a North Carolina Registered Engineer or Architect is provided.

3.11.3 Ramps

Ramps shall be at least three feet (3') in clear width. Ramps shall have a maximum slope of one unit vertical in twelve units horizontal.

Exception: Where it is technically infeasible to comply because of site constraints, ramps may have a maximum slope of one unit vertical in eight units horizontal.

A minimum 3 ft. x 3 ft. landing shall be provided: 1) at the top and bottom of ramps, 2) where doors open onto ramps, and 3) where ramps change direction.

Handrails shall be provided on at least one side of all ramps exceeding a slope of one unit vertical in 12 units horizontal. Handrail height, measured above the finished surface of the ramp slope, shall be not less than 34" and not more than 38". Handrails, where required on ramps, shall be continuous for the full length of the ramp and shall be returned or shall terminate in newel posts or safety terminals. Grip size shall comply with **Section 3.11.2.7**.

3.11.3.1 Footings for Ramps

All support posts for exterior ramp structures shall rest on a minimum 8" x 16" x 4" thick concrete masonry or 8" x 16" x 6" thick poured in place concrete footing. The bottom of such footings shall be not less than as indicated in **Table 3.5.2**.

EXCEPTION: Ramp structures that are designed by a North Carolina registered engineer specifically to be set directly on the ground do not require footings as described above.

3.11.4 Landings

A minimum 3 ft. x 3 ft. landing shall be required at the top of all exterior stairs where any egress door (not screen or storm door) swings outward over the stairs. Landings which are thirty-six (36) square feet or less in area may be constructed according to the provisions of this Code. All such landings, whether at the top or bottom of the stairs, which are greater than thirty-six (36) square feet in area are considered to be "decks" and shall be constructed in accordance with the North Carolina Residential Code (current Edition).

3.11.5 Fasteners

Fasteners used in the construction of stairs, handrails, guardrails, ramps, and landings shall be hot-dipped, zinc coated galvanized or stainless steel.

3.11.6 Auxiliary Structures

All auxiliary structures (such as porches, decks, awning, cabanas, etc.) not provided or approved by the home manufacturer, shall be entirely self-supporting unless designed and approved by a North Carolina Registered Engineer or Architect. All such structures shall be constructed in accordance with the North Carolina Residential Code (current Edition).

3.12 ELECTRICAL REQUIREMENTS

3.12.1 Electrical Requirements -- General

All electrical conductors and equipment installed within or on manufactured homes as part of the dwelling shall comply with the North Carolina State Electrical Code, current edition; except that the original unaltered factory wiring of the manufactured home may comply with either the North Carolina State Electrical Code current edition, or Parts I and II of Article 550 of the National Electrical Code (NEC), 2005. All field installed electrical appurtenances connected or attached to such manufactured homes including service equipment, feeders, service entrance conductors, additional lighting and receptacles, and field installed HVAC systems shall comply with the North Carolina State Electrical Code, current edition.

3.12.1.1 Bonding

The metal frame of a manufactured home shall be bonded to the equipment grounding bus in the in the manufactured home's panel board. The bonding conductor shall not have a connection to the grounded conductor (neutral) bus except in the service equipment. The installation and connections of the bonding conductor shall comply with the North Carolina State Electrical Code, current edition.

3.12.2 Electrical Inspections for Manufactured Home Dealer Lots

3.12.3 Miscellaneous Lights and Fixtures

Some homes may be delivered with exterior lights, ceiling fans, and chain-hung fixtures not yet installed. Each of these fixtures must be grounded by a fixture grounding screw or wire. For chain-hung fixtures, use both grounding methods. When fixtures are mounted on combustible surfaces such as hardboard, install a noncombustible ring to completely cover the combustible surface exposed between the fixture canopy and the wiring outlet box. If siding has not been installed at a fixture location, remove the outlet box and install the siding with a hole for the outlet box. Then reinstall the outlet box and proceed as for other fixtures. All fixtures shall be installed in accordance with their listing.

3.12.3.1 Exterior Lights

Remove the junction box covers and make wire-to-wire connections using wire nuts. Connect black wires to black, white to white, and ground to ground. Push the wires into the box and secure the light fixture to the junction box. Caulk around the base of the light fixture to ensure a water-tight seal to the sidewall.

3.12.3.2 Ceiling Fans

Ceiling fans shall be installed with the trailing edges of the blades at least 6 feet 4 inches above the floor.

CAUTION: BEFORE FOLLOWING THE STEP-BY-STEP PROCEDURE BELOW, BE SURE THAT POWER TO FAN WIRE CIRCUIT IS TURNED OFF AT THE PANEL BOX.

1. Remove the fan manufacturer's installation instructions from the package and determine the method of fan attachment to the beam.
2. If the center beam (shipped loose) does not contain a precut hole for the electrical box, cut a hole with a hole saw approximately 1/4" larger than the box diameter at the proper location (center line of hole should line up with location of supply wire through ceiling) and centered in the width of the beam.
3. Install the box in the hole and secure flange to the center beam with 4 - #6 x 1" screws.
4. Insert the ceiling wire through a knock out hole in the side of the electrical box. NOTE: It may be necessary to cut a notch from the top on the supply wire side of the center beam hole to allow the supply wire to be inserted in electrical box without binding against center beam during installation. Leave approximately 4" of wire free in the box.
5. Secure the center beam in place over the center line joint. Be sure that fan supply wire is not pinched or penetrated with beam fasteners.
6. Secure electrical box to ridge beam with #8 x 2 1/2" wood screws through the two holes in the top of the box.
7. Strip about 3/4" of insulation from the white and black conductor ends.
8. Position the non-combustible flash ring (provided) over the electrical box so that finished surface (adjacent to electrical box) which is to be covered by fan canopy is not exposed.
9. Follow the manufacturer's installation instructions for mounting the fan assembly to the box and for electrical wiring of the fan. Use provided electrical connectors for splicing wire. Be certain that fan is grounded as specified in manufacturer's instructions and that wires are connected properly (white-to-white and black-to-black).

NOTE: Installation of a ceiling fan when the home has a protruding ridge beam will differ slightly from the above. Follow the fan manufacturer's installation instructions.

3.12.4 Electrical Testing

Although Federal Regulations require that dielectric, continuity, operational, and polarity tests be performed at the factory in accordance with **550.17**, the manufacturer may also require testing at the site.

The following Sections describe normal testing procedures at the site. However, specific testing requirements described in the Manufacturer's Installation Instructions should be followed.

3.12.4.1 Continuity Test

The continuity test is made between an accessible connection with the equipment ground (grounding bus) and all noncurrent-carrying metal parts. The accessible connection to ground may be the ground bus in the panel, a noncurrent-carrying metal part such as the frame, metal siding, or range hood that is bonded to the grounding bus, or the ground prong on outlets. Any noncurrent-carrying metal part may be used as the grounding point as long as one check is made to assure that there is continuity with the ground bus in the electrical panel.

1. Using a continuity tester, test all noncurrent-carrying metal parts to assure continuity to ground.

Noncurrent-carrying parts to be checked include the following:

a) Appliance enclosures, including fans.

b) Fixture enclosures and canopies.

(Note: If the manufacturer checks the polarity of fixtures by conducting a polarity test, it is not necessary to conduct a separate continuity test of the same fixtures. A polarity tester with connectors will check adequate bonding.)

c) Metal siding.

d) Metal roof, especially if a nonmetallic siding is used.

e) Metal water supply lines.

f) Metal HVAC ducts (foil covered insulated ducts do not need to be checked).

g) Gas lines.

h) Manufactured home frame.

On multi-wide units, this test shall be performed only after all electrical connections between the units are completed. Bonding between the frames of individual units must also be completed as shown in the Manufacturer's Installation Instructions.

2. Failure to assure continuity to ground requires repair and retesting.

3.12.4.2 Polarity Test

The polarity test shall be performed as follows:

1. Turn the main circuit breaker and each individual circuit breaker on.
2. Using equipment that is capable of determining an incorrect wiring configuration, check each 120-volt receptacle and light socket for correct polarity. A conversion device may be required to test various fixture bulb sizes and outlet configurations.
3. GFCI-protected receptacle outlets should be tested to assure that the circuit is open after the test button on the outlet has been depressed.
4. Faulty electrical wiring and fixtures require repair and retesting.

3.12.4.3 Operational Test

The operational test shall be performed as follows (note that the operational test may be performed concurrently with the polarity test):

1. All circuit breakers are to be turned on.
2. Check all light fixtures by placing a bulb in the socket and turning the switch on and off.
3. Using a pigtail light, check all 240-volt receptacles to determine if there is power going to both legs of the circuit.
4. Check all 120-volt receptacles to be sure that each is operational. This check may be made with a polarity tester or a pigtail light. Switched receptacles require the switch to be turned on and off. Appliances such as stoves, ranges, washers, dryers, water heaters, furnaces, air conditioners, evaporative coolers, and heat exchangers do not have to be checked to be sure they are operational. However, the power source must be assured.
5. Check all receptacles on a GFCI circuit by pushing the test button to determine if the power route to the receptacle has been interrupted. Be sure that the receptacles requiring GFCI protection are on the correct circuit.
6. Failure of electrical wiring or fixtures requires repair and retesting.

3.12.5 Telephone and Cable TV

The walls and floors of a manufactured home contain electrical circuits, plumbing, and duct work. Therefore, careless installation of telephone and cable television lines may result in serious electrical shock hazards as well as damage to the home. Contact with these systems must be avoided when drilling through and placing cables within wall and floor cavities. Only trained professionals should handle such work. Failure to follow these instructions could result in serious personal injury or death.

3.13 PLUMBING REQUIREMENTS

3.13.1 SITE INSTALLED PLUMBING – ADMINISTRATION

3.13.1.1 Inspection Required

All plumbing work performed on site and parts of existing systems affected by new work or alterations shall be inspected by the building official to ensure compliance with the requirements of this Code. All plumbing requirements specified in this Code are taken directly from the **North Carolina Plumbing Code**, current edition. If plumbing issues are encountered that are not specifically addressed in this Code, all materials and installation of same shall comply with the **North Carolina Plumbing Code**, current edition.

3.13.1.2 Concealment

A site installed plumbing or drainage system, or part thereof, shall not be covered, concealed or put into use until it has been tested, inspected, and approved by the building official.

3.13.1.3 Responsibility of Installer

Test equipment, materials and labor shall be furnished by the installer.

3.13.1.4 Licensed Plumber Requirements

Plumbing and heating contractors are regulated by Article 2 of NC General Statute 87. Section § 87-21 (c1) of Article 2 states the following:

Exemption -- The provisions of this Article shall not apply to a person who performs the on-site assembly of a factory designed drain line system for a manufactured home as defined in G.S. 143-143.9 (6), if the person (i) is a licensed manufactured home dealer, a licensed manufactured home set-up contractor, or a full-time employee of either, (ii) obtains an inspection by the local inspections department and (iii) performs the assembly according to the State Plumbing Code.

Based on the above, a licensed set-up contractor, a licensed dealer, or any full time employee of either may install the factory designed drain line system that falls within the outside perimeter of the home. Such installations shall be according to the Manufacturer's Installation Instructions and shall fully conform to the provisions of this Code and the **North Carolina Plumbing Code**, current edition, for any conditions encountered that are not specifically addressed in this Code. Note that, if a factory designed drain line system does not match local site conditions, a new factory designed system matching the existing site conditions is required or the drain line must be installed by a licensed plumbing contractor.

A licensed plumbing contractor is **required** for the following:

- 1) All underground work.
- 2) All work outside the skirting of the home.
- 3) Any work not conforming to a factory designed drain line system.
- 4) All on-site plumbing on USED manufactured homes for which the Manufacturer's Installation Instructions are not available.

In all cases the assembly shall be installed in accordance with the **North Carolina Plumbing Code**, current edition.

3.13.1.5 Temporary Toilet Facilities at Construction Sites

Toilet facilities shall be provided and maintained in a sanitary condition during construction. Where there are less than 20 workers at the site, a minimum of one (1) toilet shall be provided. Such facilities may be portable, enclosed, chemically treated, tank-tight units. Portable toilets shall be enclosed, screened and weatherproofed with internal latches. There shall be at least one facility for every two contiguous construction sites.

Where there are more than 20 workers at a given site, see **Section 311** in *the NC Plumbing Code, current edition* for the required number of facilities.

Temporary toilet facilities need not be provided on site for crews on a job site for no more than one working day and having transportation readily available to toilet facilities.

3.13.2 PLUMBING DEFINITIONS

ACCESS (TO). That which enables a fixture, appliance or equipment to be reached by ready *access* or by a means that first requires the removal or movement of a panel, door or similar obstruction (see “Ready *access*”).

APPROVED — approved by the code official or other authority having jurisdiction.

AUTHORITY HAVING JURISDICTION — the organization, office, or individual responsible for approving plans, equipment, installations, or alteration procedures.

BACKFLOW, DRAINAGE --- A reversal of flow in the drainage system.

BACKWATER VALVE --- A device or valve installed in the building drain or sewer pipe where a sewer is subject to backflow, and which prevents drainage or waste from backing up into a lower level or fixtures and causing a flooding condition.

BUILDING DRAIN --- That part of the lowest piping of a drainage system that receives the discharge from soil, waste and other drainage pipes inside and that extends to 10 feet beyond the walls of the building and conveys the drainage to the building sewer.

BUILDING SEWER --- That part of the drainage system that extends from the end of the building drain and conveys the discharge to a public sewer, private sewer, individual sewage disposal system or other point of disposal.

CLEANOUT --- An access opening in the drainage system utilized for the removal of obstructions. Types of cleanouts include a removable plug or cap, and a removable fixture or fixture trap.

DEAD END --- A branch leading from a soil, waste, or vent pipe, a building drain, or a building sewer, and terminating at a developed length of 2 feet or more by means of a plug, cap or other closed fitting.

POTABLE WATER --- Water free from impurities present in amounts sufficient to cause disease or harmful physiological effects and conforming to the bacteriological and chemical quality requirements of the Public Health Service Drinking Water Standards or the regulations of the public health authority having jurisdiction.

PRESSURE RELIEF VALVE --- A pressure-actuated valve held closed by a spring or other means and designed to relieve pressure automatically at the pressure at which such valve is set.

PUBLIC SEWER --- A common sewer directly controlled by public authority.

PUBLIC WATER MAIN --- A water supply pipe for public utilization controlled by public authority.

READY ACCESS. That which enables a fixture, appliance or equipment to be directly reached without requiring the removal or movement of any panel, door or similar obstruction and without the use of a portable ladder, step stool or similar device.

SEPTIC TANK --- A water-tight receptor which receives the discharge of a building sanitary drainage system and is constructed so as to separate solids from the liquid, digest organic matter through a period of detention, and allow the liquids to discharge into the soil outside of the tank through a system of open joint or perforated pipe or a seepage pit.

SEWAGE --- Any liquid waste containing animal or vegetable matter in suspension or solution, including liquids containing chemicals in solution.

SLOPE --- The fall (pitch) of a line of pipe in reference to a horizontal plane. In drainage, the slope is expressed as the fall in units vertical per units horizontal (percent) for a length of pipe.

SUPPORTS --- Devices for supporting and securing pipe, fixtures, and equipment.

WATER DISTRIBUTION SYSTEM --- Piping which conveys water from the service to the plumbing fixtures, appliances, appurtenances, equipment, devices or other systems served, including fittings and control valves.

WATER MAIN --- A water supply pipe or system of pipes, installed and maintained by a city, township, county, public utility company or other public entity, on public property, in the street or in an approved dedicated easement of public or community use.

WATER DISTRIBUTION PIPE -- A pipe within the structure or on the premises that conveys water from the water service pipe, or from the meter when the meter is at the structure, to the points of utilization.

WATER SERVICE PIPE --- The pipe from the water main or other source of potable water supply, or from the meter when the meter is at the public right of way, to the water distribution system of the building served. Water service pipe shall terminate 5 feet outside the foundation wall.

WATER SUPPLY SYSTEM --- The water service pipe, water distribution pipes, and the necessary connecting pipes, fittings, control valves and all appurtenances in or adjacent to the structure or premises.

3.13.3 GENERAL REGULATIONS

3.13.3.1 Connections to the Sanitary Drainage System

All plumbing fixtures, drains, appurtenances and appliances used to receive or discharge liquid wastes or sewage shall be directly connected to the drainage system of the building in accordance with the requirements of this Code.

3.13.3.2 Connections to Water Supply

Every plumbing fixture, device or appliance requiring or using water for its proper operation shall be directly or indirectly connected to the water supply system in accordance with the provisions of this Code. A pressure reducing valve shall be installed if the incoming water supply pressure is in excess of 80 psi.

3.13.3.3 MATERIALS

3.13.3.3.1 Identification

Each length of pipe and each pipe fitting, trap, fixture, material and device utilized in a plumbing system shall bear the identification of the manufacturer and the applicable standard to which it was manufactured.

3.13.3.3.2 Plastic Pipe, Fittings and Components

All plastic pipe, fittings and components shall be third-party certified as conforming to NSF 14.

3.13.3.4 PROTECTION OF PIPES AND PLUMBING SYSTEM COMPONENTS

3.13.3.4.1 Corrosion

Pipes passing through concrete or cinder walls and floors or other corrosive material shall be protected against external corrosion by a protective sheathing or wrapping or other means that will withstand any reaction from the lime and acid of concrete, cinder, or other corrosive material. Sheathing or wrapping shall allow for movement including expansion and contraction of piping. Minimum wall thickness of material shall be 0.025 inches.

3.13.3.4.2 Breakage

Pipes passing through or under walls shall be protected from breakage.

3.13.3.4.3 Stress and Strain

Piping in a plumbing system shall be installed so as to prevent strains and stresses that exceed the structural strength of the pipe. Where necessary, provisions shall be made to protect piping from damage resulting from expansion, contraction, and structural settlement.

3.13.3.4.4 Sleeves

Annular spaces between sleeves and pipes shall be filled or tightly caulked in an approved manner.

3.13.3.4.5 Pipes Through or under Footings or Foundation Walls

Any pipe that passes within 12 inches under a footing or through a foundation wall shall be provided with a relieving arch, or a pipe sleeve pipe shall be built into the foundation wall. The sleeve shall be two pipe sizes greater than the pipe passing through the wall. Piping shall not be run under pier footings.

3.13.3.4.6 Freezing

The top of water pipes, installed below grade outside the building, shall be below the frost line or a minimum of 12 inches below finished grade, whichever is greater.

3.13.3.4.6.1 Frost Protection

No traps of soil or waste pipe shall be installed or permitted outside of a building, or concealed in outside walls or in any place where they may be subjected to freezing temperatures, unless adequate provision is made to protect them from freezing. Waste and soil piping leaving the building shall have a minimum cover of 3 inches.

3.13.3.5 TRENCHING, EXCAVATION AND BACKFILL

3.13.3.5.1 Support of Piping

Buried piping shall be supported throughout its entire length.

3.13.3.5.2 Trenching and Bedding

Where trenches are excavated such that the bottom of the trench forms the bed for the pipe, solid and continuous loadbearing support shall be provided between joints. Bell holes, hub holes, and coupling holes shall be provided at points where the pipe is joined. Such pipe shall not be supported on blocks to grade. In instances where the materials manufacturer's installation instructions are more restrictive than those prescribed by the Code, the material shall be installed in accordance with the more restrictive requirement.

3.13.3.5.2.1 Overexcavation

Where trenches are excavated below the installation level of the pipe such that the bottom of the trench does not form the bed for the pipe, the trench shall be backfilled to the installation level of the bottom of the pipe with sand or fine gravel placed in layers of 6 inches maximum depth and such backfill shall be compacted after each placement.

3.13.3.5.2.2 Rock Removal

Where rock is encountered in trenching, the rock shall be removed to a minimum of 3 inches below the installation level of the bottom of the pipe, and the trench shall be backfilled to the installation level of the bottom of the pipe with sand tamped in place so as to provide uniform loadbearing support for the pipe between joints. The pipe, including the joints, shall not rest on rock at any point.

3.13.3.5.2.3 Soft Loadbearing Materials

If soft materials of poor loadbearing qualities are found at the bottom of the trench, stabilization shall be achieved by overexcavating a minimum of two pipe diameters and backfilling to the installation level of the bottom of the pipe with fine gravel, crushed stone or a concrete foundation. The concrete foundation shall be bedded with sand tamped into place so as to provide uniform loadbearing support for the pipe between joints.

3.13.3.5.3 Backfilling

Backfill shall be free from discarded construction material and debris. Loose earth free from rocks, broken concrete and frozen chunks shall be placed in the trench in 6 inch layers and tamped in place until the crown of the pipe is covered by 12 inches of tamped earth. The backfill under and beside the pipe shall be compacted for pipe support. Backfill shall be brought up evenly on both sides of the pipe so that the pipe remains aligned. In instances where the manufacturer's installation instructions for materials are more restrictive than those prescribed by the Code, the material shall be installed in accordance with the more restrictive requirement.

3.13.3.6 PIPING SUPPORT

3.13.3.6.1 General

All plumbing piping shall be supported in accordance with this Section.

3.13.3.6.2 Materials

Hangers, anchors and supports shall support the piping and contents of the piping. Hangers and strapping material shall be of *approved* material that will not promote galvanic action.

3.13.3.6.3 Structural Attachment

Hangers and anchors shall be attached to the building construction in an *approved* manner.

3.13.3.6.4 Interval of Support

Pipe shall be supported in accordance with the following:

| <u>Piping Material</u> | <u>Max. Horizontal Spacing</u> |
|---|--------------------------------|
| <u>ABS pipe</u> | <u>4 feet</u> |
| <u>Cross-linked polyethylene (PEX) pipe</u> | <u>32 inches</u> |
| <u>CPVC pipe or tubing, 1 inch or smaller</u> | <u>3 feet</u> |
| <u>PVC pipe</u> | <u>4 feet</u> |

Any piping material utilized that is not listed above shall be supported at intervals specified in the **North Carolina Plumbing Code**, current edition.

3.13.3.6.5 Stacks

Bases of stacks shall be supported by the building structure, undisturbed or compacted earth, or other material suitable to support the weight of the piping.

3.13.3.7 TESTING

3.13.3.7.1 DWV System Testing

As required by Federal Standards, the factory installed portion of the drainage, waste, and vent (DWV) system has been tested at the manufacturing facility by one of the following methods: a water test, an air test, or a flood level test. The *SITE-INSTALLED PORTION* of the DWV system for all homes shall also be tested at the site in accordance with **Section 3.13.3.7.1.1**.

3.13.3.7.1.1 Test for Site-Installed Portion of DWV System

The *SITE-INSTALLED PORTION* of the DWV system shall be tested by EITHER

a. A water test in which the *SITE-INSTALLED PORTION* is subject to a head of water not less than 3 ft. above the highest site-completed fitting. The 3 ft. head of water shall be kept in the system for at least 15 minutes before inspection starts.

OR

b. An air test in which the *SITE-INSTALLED PORTION* of the DWV system shall be subjected to an air test by a method suitable to the local Code official. The air test shall be made by forcing air into the system until there is a uniform gauge pressure of 5 lbs. per square inch. This pressure shall be held for a test period of at least 15 minutes.

(See **Figure 3.13.3.7** for one suggested method for testing the DWV system).

MANUFACTURED HOUSING DWV TEST PROCEDURES

(NOTE: THIS IS ONLY ONE METHOD TO TEST THE DWV SYSTEM. THERE MAY BE OTHER METHODS WHICH ALSO MEET THE CODE REQUIREMENTS)

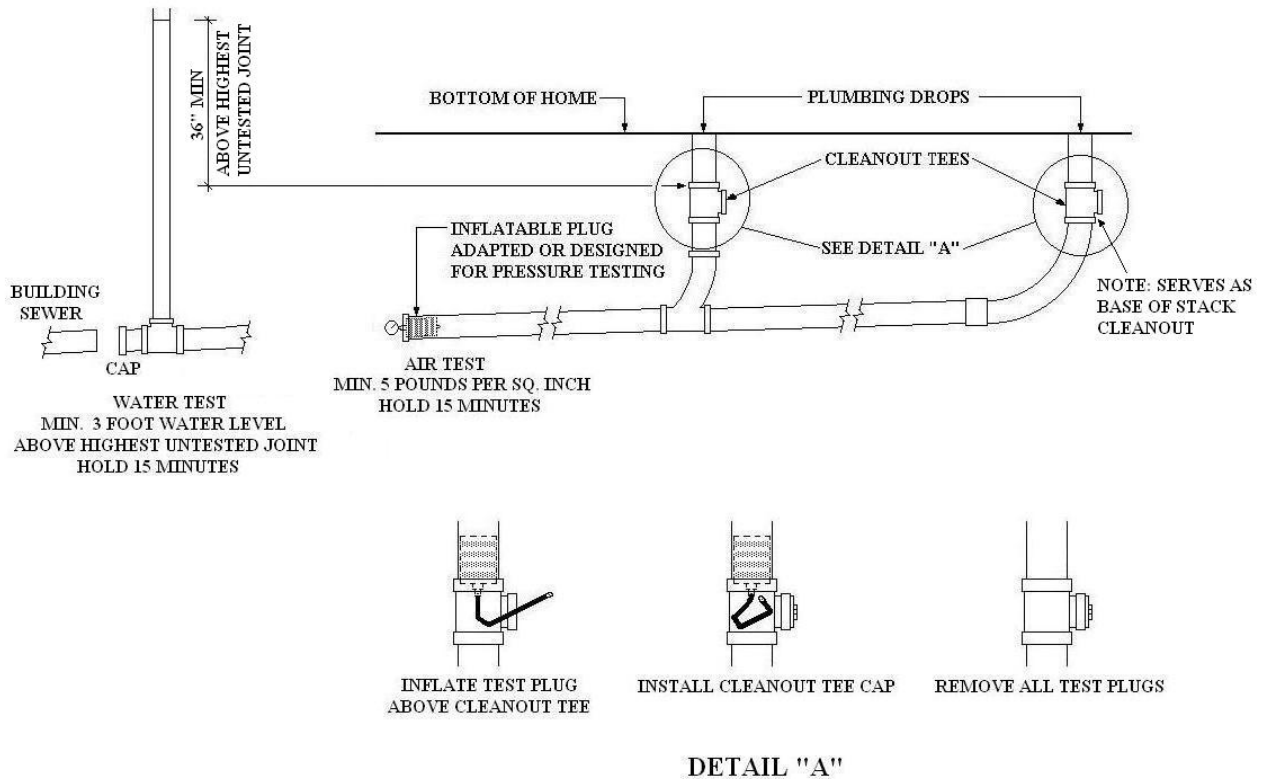

1. INSERT AND INFLATE TEST PLUGS ABOVE CLEANOUT TEES
2. INSTALL CLEANOUT TEE CAPS
3. USE EITHER WATER TEST OR AIR TEST
4. REMOVE ALL TEST PLUGS AND TEST APPARATUS
5. MAKE FINAL CONNECTION TO BUILDING SEWER

FIGURE 3.13.3.7

3.13.3.7.1.2 Fixture Test

As required by Federal Standards, factory installed plumbing fixtures and connections have been tested prior to leaving the manufacturing facility. No additional testing of fixtures is required at the site unless there is evidence of physical damage.

3.13.3.7.2 Water Distribution System Testing

As required by Federal Standards, the factory installed water distribution system has been tested prior to leaving the manufacturing facility. The *SITE-INSTALLED PORTION* of the water distribution system shall be tested at the site. All homes shall have *SITE-INSTALLED PORTION* of the water distribution system tested at the site by the method specified in **Section 3.13.3.7.2.1**.

3.13.3.7.2.1 Pressure Test for Water Distribution System

Water distribution tests shall be carried out as follows:

Upon completion on site of the water distribution system, the *SITE-INSTALLED PORTION* of the system shall be tested under a water pressure of not less than the working pressure of the system or, for piping systems *other than plastic*, by an air test of not less than 100 psi. This pressure shall be held for at least 15 minutes. While under the required pressure, the system shall be visually inspected for leaks and proper use and installation of materials, joints, and connections in accordance with the provisions of this Code or, for situations not covered in this Code, in accordance with the **North Carolina Plumbing Code**, current edition. The water utilized for tests shall be obtained from a potable source of supply. Any occurrences of leaks or improper use or installation of materials, joints, and connections shall be corrected prior to issuing a Certificate of Occupancy for the home. Note that, for well systems, the working pressure test must be performed after electrical power has been supplied to the site. As an alternate, a generator may be utilized.

3.13.3.7.3 Completion of Testing Procedures

Completion of the test procedures given in **Sections 3.13.3.7.1.1** and **3.13.3.7.2.1** shall be considered as meeting the plumbing test requirements of this Code. If the tests in **Sections 3.13.3.7.1.1** and **3.13.3.7.2.1** are satisfactorily completed, *no additional tests shall be required by the local inspection jurisdiction.*

3.13.4 WATER SUPPLY AND DISTRIBUTION

3.13.4.1 WATER REQUIRED

3.13.4.1.1 Potable Water Required

Only potable water shall be supplied to plumbing fixtures that provide water for drinking, bathing or culinary purposes.

3.13.4.1.2 Individual Water Supply

Where a potable public water supply is not available, individual sources of potable water supply shall be utilized.

3.13.4.1.3 Disinfection of Potable Water System

Permitted new or repaired potable water systems shall be purged of deleterious matter prior to utilization.

3.13.4.2 WATER SERVICE

3.13.4.2.1 Minimum Size of Water Service Pipe

The minimum diameter of water service pipe shall be 3/4 inch.

3.13.4.2.2 Separation of Water Service and Building Sewer

Water service pipe and the *building sewer* shall be separated by 5 feet of undisturbed or compacted earth.

EXCEPTION:

1. The required separation distance shall not apply where the bottom of the water service pipe within 5 feet of the sewer is a minimum of 12 inches above the highest point of the sewer and the pipe materials conform to **Sections 3.13.7.4.2** and **3.13.7.4.3**.
2. Water service pipe is permitted to be located in the same trench with a building sewer, provided such sewer is constructed of materials listed in **Section 3.13.7.4.3**.

3.13.4.2.2.1 Water Service Near Sources of Pollution

Potable water service pipe shall not be located in, under, or above cesspools, septic tanks, septic tank drainage fields or seepage pits.

3.13.4.3 DESIGN WATER PRESSURE

3.13.4.3.1 Water-Pressure Reducing Valve or Regulator

Manufactured homes are designed for an inlet water pressure of 80 psi. Where water pressure supplied to the home exceeds 80 psi static, an *approved* water-pressure reducing valve conforming to ASSE 1003 with strainer shall be installed to reduce the pressure in the home water distribution piping to 80 psi static or less.

3.13.4.3.1.1 Valve Design

The pressure reducing valve shall be designed to remain open to permit uninterrupted flow in case of valve failure.

3.13.4.3.1.2 Repair and Removal

All water pressure reducing valves, regulators and strainers shall be so constructed and installed as to permit repair or removal of parts without breaking a pipeline or removing the valve and strainer from the pipeline.

3.13.5 MATERIAL, JOINTS AND CONNECTIONS

3.13.5.1 Water Service Pipe

Water service pipe shall conform to NSF 61 and shall conform to one of the standards listed in **Section 3.13.5.2**. **Section 3.13.5.2** lists materials commonly used in manufactured home applications. Note that approved materials for water service pipe that are listed in the **North Carolina Plumbing Code**, current edition, but not listed in **Section 3.13.5.2**, shall also be

permissible. All water service pipe or tubing, installed underground and outside the structure, shall have a minimum working pressure rating of 160 psi at 73.4° F. Water service piping materials not third-party certified for water distribution shall terminate 5 feet outside the building.

3.13.5.2 Water Service Pipe Materials

| <u>Piping Material</u> | <u>Standard</u> |
|--------------------------|--|
| <u>ABS plastic pipe</u> | <u>ASTM D 1527; ASTM D 2282</u> |
| <u>CPVC plastic pipe</u> | <u>ASTM D 2846; ASTM F 441; ASTM F 442</u> |
| <u>PVC plastic pipe</u> | <u>ASTM D 1785; ASTM D 2241; ASTM D 2672</u> |

3.13.5.3 Water Distribution Pipe

Water distribution pipe shall conform to NSF 61 and shall conform to one of the standards listed in **Section 3.13.5.4**. **Section 3.13.5.4** lists materials commonly used in manufactured home applications. Note that approved materials for water distribution pipe that are listed in the **North Carolina Plumbing Code**, current edition, but not listed in **Section 3.13.5.4**, shall also be permissible. All water distribution pipe and tubing shall have a minimum pressure rating of 100 psi at 180° F.

3.13.5.4 Water Distribution Pipe Materials

| <u>Piping Material</u> | <u>Standard</u> |
|---|--|
| <u>CPVC plastic pipe and tubing</u> | <u>ASTM D 2846; ASTM F 441; ASTM F 442</u> |
| <u>Cross-linked polyethylene (PEX) plastic tubing</u> | <u>ASTM F 876; ASTM F 877</u> |

3.13.5.5 Fittings

Pipe fittings shall be approved for installation with the piping material installed and shall conform to the respective pipe standards or one of the standards listed in **Section 3.13.5.6**. **Section 3.13.5.6** lists materials commonly used in manufactured home applications. Note that approved materials for pipe fittings that are listed in the **North Carolina Plumbing Code**, current edition, but not listed in **Section 3.13.5.6**, shall also be permissible. All pipe fittings utilized in water supply systems shall also comply with NSF 61. The fittings shall not have ledges, shoulders or reductions capable of retarding or obstructing flow in the piping.

3.13.5.6 Pipe Fittings

| <u>Material</u> | <u>Standard</u> |
|--|--|
| <u>ABS plastic</u> | <u>ASTM D 2468</u> |
| <u>CPVC plastic</u> | <u>ASSE 1061; ASTM D 2846; ASTM F 437; ASTM F 438; ASTM F 439</u> |
| <u>Fittings for cross-linked polyethylene (PEX) plastic tubing</u> | <u>ASSE 1061; ASTM F 877; ASTM F 1807; ASTM F 1960; ASTM F 2080; ASTM F 2098; ASTM F 2159; ASTM F 2434</u> |
| <u>PVC plastic</u> | <u>ASTM D 2464; ASTM D 2466; ASTM D 2467</u> |

3.13.5.7 Valves

All valves shall be of the approved type and compatible with the type of piping material installed in the system. Ball valves, gate valves, globe valves and plug valves intended to supply drinking water shall meet the requirements of NSF 61.

3.13.5.8 Prohibited Joints and Connections

The following types of joints and connections shall be prohibited:

1. Joints made with fittings not approved for the specific installation.
2. Solvent-cement joints between different types of plastic pipe.
3. Saddle-type fittings.

3.13.5.9 Allowable Types of Joints

The types of pipe joints listed in this Section are commonly used in manufactured housing. Joints shall be as specified in this Section, except joints listed for approved materials in the **North Carolina Plumbing Code**, current edition, that are not listed in this Section, shall be permissible.

3.13.5.9.1 ABS Plastic

Joints between ABS plastic pipe or fittings shall comply with **Section 3.13.5.9.1.1** or **3.13.5.9.1.2**.

3.13.5.9.1.1 Mechanical Joints

Mechanical joints on water pipes shall be made with an elastomeric seal conforming to ASTM D 3139. Mechanical joints shall only be installed in underground systems, unless otherwise approved. Joints shall be installed only in accordance with the manufacturer's instructions.

3.13.5.9.1.2 Solvent Cementing

Joint surfaces shall be clean and free from moisture. Solvent cement that conforms to ASTM D 2235 shall be applied to all joint surfaces. The joint shall be made while the cement is wet. Joints shall be made in accordance with ASTM D 2235. Solvent cement joints shall be permitted above or below ground.

3.13.5.9.2 CPVC Plastic

Joints between CPVC plastic pipe or fittings shall comply with **Section 3.13.5.9.2.1** or **3.13.5.9.2.2**.

3.13.5.9.2.1 Mechanical Joints

Mechanical joints shall be installed in accordance with the manufacturer's instructions.

3.13.5.9.2.2 Solvent Cementing

Joint surfaces shall be clean and free from moisture, and an approved primer shall be applied. Solvent cement, orange in color and conforming to ASTM F 493 shall be applied to all joint surfaces. The joint shall be made while the cement is wet, and in accordance with ASTM D 2846 or ASTM F 493. Solvent cement joints shall be permitted above or below ground.

Exception: A primer is not required where ALL of the following conditions apply :

1. The solvent cement used is third-party certified as conforming to ASTM F493.
2. The solvent cement used is yellow in color.
3. The solvent cement is used only for joining 1/2" through 2" diameter CPVC pipe and fittings.
4. The CPVC pipe and fittings are manufactured in accordance with ASTM D 2846.

3.13.5.9.3 Cross-Linked Polyethylene (PEX) Plastic

Joints between cross-linked polyethylene plastic tubing or fittings shall comply with **Section 3.13.5.9.3.1** or **3.13.5.9.3.2**.

3.13.5.9.3.1 Flared Joints

Flared pipe ends shall be made by a tool designed for that operation.

3.13.5.9.3.2 Mechanical Joints

Mechanical joints shall be installed in accordance with the manufacturer's instructions. Fittings for cross-linked polyethylene (PEX) plastic tubing shall comply with the applicable standards listed in **Section 3.13.5.6** and shall be installed in accordance with the manufacturer's instructions. PEX tubing shall be factory marked with the appropriate standards for the fittings that the PEX manufacturer specifies for use with the tubing.

3.13.5.9.4 PVC Plastic

Joints between PVC plastic pipe or fittings shall comply with **Section 3.13.5.9.4.1** or **3.13.5.9.4.2**.

3.13.5.9.4.1 Mechanical Joints

Mechanical joints on water pipe shall be made with an elastomeric seal conforming to ASTM D 3139. Mechanical joints shall not be installed in above-ground systems unless otherwise approved. Joints shall be installed in accordance with the manufacturer's instructions.

3.13.5.9.4.2 Solvent Cementing

Joint surfaces shall be clean and free from moisture. A purple primer or an ultraviolet purple primer that conforms to ASTM F 656 shall be applied. When an ultraviolet primer is used, the installer shall provide an ultraviolet light to the inspector to be used during the inspection. Solvent cement not purple in color and conforming to ASTM D 2564 shall be applied to all joint surfaces. The joint shall be made while the cement is wet and shall be in accordance with ASTM D 2855. Solvent cement joints shall be permitted above or below ground.

3.13.5.9.5 Joints Between Different Materials

Joints between different piping materials shall be made with a mechanical joint of the compression or mechanical sealing type, or as permitted in **Section 3.13.5.9.5.1**. Connectors or adapters shall have an elastomeric seal conforming to ASTM D 1869 or ASTM F 477. Joints shall be installed in accordance with the manufacturer's instructions.

3.13.5.9.5.1 Plastic Pipe or Tubing to Other Piping Material

Joints between different grades of plastic pipe or between plastic pipe and other piping material shall be made with an approved adapter fitting.

3.13.6 REQUIREMENTS FOR WATER SUPPLY AND DISTRIBUTION SYSTEM

3.13.6.1 Location of Main Shutoff Valve

The main shutoff valve shall be a full-open valve and shall be installed on the water distribution supply pipe in the interior of the building in a location where it may be accessed without the use of a ladder or a tool, in the crawl space within 3 feet of the access door or of a panel which is removable without the use of tools (see **Section 3.6.6**), or in a readily accessible valve box within 5 feet of the skirting.

3.13.6.2 Pipe Outside the Skirting of the Home

Pipes outside the skirting of the home shall be installed below grade and in accordance with **Sections 3.13.3.4** and **3.13.3.5**.

3.13.6.3 Access to Valves

Access shall be provided to all full-open valves and shutoff valves.

3.13.6.4 Valve Identification

Main service valves shall be identified.

3.13.6.5 Thermal Expansion Control in Hot Water Supply System

A means of controlling increased pressure caused by thermal expansion shall be provided where required in accordance with **Sections 3.13.6.5.1** and **3.13.6.5.2**.

3.13.6.5.1 Pressure-Reducing Valve

For water service systems up to and including 2 inches, a device for controlling pressure shall be installed where, because of thermal expansion, the pressure on the downstream side of a pressure-reducing valve exceeds the pressure-reducing valve setting.

3.13.6.5.2 Backflow Prevention Device or Check Valve

Where a backflow prevention device, check valve or other device is installed on a water supply system utilizing storage water heating equipment such that thermal expansion causes an increase in pressure, a device for controlling pressure shall be installed.

3.13.6.6 Protection of Potable Water Supply

A potable water supply system shall be designed, installed, and maintained in such a manner so as to prevent contamination from nonpotable liquids, solids or gases being introduced into the potable water supply through cross connections or any other piping connections to the system. Backflow preventer applications, where required, shall be in accordance with the **North Carolina State Plumbing Code**, current edition.

3.13.6.6.1 Water Service Piping

Water service piping shall be protected in accordance with **Sections 3.13.4.2.2** and **3.13.4.2.2.1**.

3.13.6.6.2 Cross Connections with Private Water Supplies

Cross connections between a private water supply and a potable public supply shall be prohibited.

3.13.6.6.3 Reuse of Piping

Piping that has been utilized for any purpose other than conveying potable water shall not be utilized for conveying potable water.

3.13.7 SANITARY DRAINAGE

3.13.7.1 Sewer Required

Every building in which plumbing fixtures are installed and all premises having drainage piping shall be connected to a public sewer, where available, or an approved private sewage disposal system.

3.13.7.2 Separate Sewer Connection

Every building having plumbing fixtures installed and intended for human habitation, occupancy or use on premises abutting a street, alley or easement in which there is a public sewer shall have a separate connection with the sewer. Where located on the same lot, multiple buildings shall not be prohibited from connecting to a common building sewer that connects to the public sewer.

3.13.7.3 Sewage Treatment

Note: The following text is provided for informational purposes only. Sewage or other waste from a plumbing system that is deleterious to surface or subsurface waters shall not be discharged into the ground or into any waterway unless it has first been rendered innocuous through proper treatment approved by the authority having jurisdiction.

3.13.7.4 MATERIALS

3.13.7.4.1 Above-Ground Sanitary Drainage and Vent Pipe

Above-ground soil, waste and vent pipe shall conform to one of the standards listed in **Section 3.13.7.4.1.1**.

Section 3.13.7.4.1.1 lists materials commonly used in manufactured home applications. Note that approved materials for above-ground soil, waste and vent pipe that are listed in the **North Carolina Plumbing Code**, current edition, but not listed in **Section 3.13.7.4.1.1**, shall also be permissible.

3.13.7.4.1.1 Above-Ground Drainage, Waste and Vent Pipe

| <u>Piping Material</u> | <u>Standard</u> |
|-------------------------|--|
| <u>ABS plastic pipe</u> | <u>ASTM D 2661; ASTM F 628; ASTM F 1488</u> |
| <u>PVC plastic pipe</u> | <u>ASTM D 2665; ASTM D 2949; ASTM F 891; ASTM F 1488</u> |

3.13.7.4.2 Underground Sanitary Drainage and Vent Pipe

Underground building sanitary drainage, waste and vent pipe shall conform to one of the standards listed in **Section**

3.13.7.4.2.1. **Section 3.13.7.4.2.1** lists materials commonly used in manufactured home applications. Note that approved materials for underground drainage, waste and vent pipe that are listed in the **North Carolina Plumbing Code**, current edition, but not listed in **Section 3.13.7.4.2.1**, shall also be permissible.

3.13.7.4.2.1 Underground Drainage, Waste and Vent Pipe

| <u>Piping Material</u> | <u>Standard</u> |
|------------------------------------|--|
| <u>ABS plastic pipe</u> | <u>ASTM D 2661; ASTM F 628; ASTM F 1488</u> |
| <u>PVC plastic pipe (Type DWV)</u> | <u>ASTM D 2665; ASTM D 2949; ASTM F 891; ASTM F 1488</u> |

3.13.7.4.3 Building Sewer Pipe

Building sewer pipe shall conform to one of the standards listed in **Section 3.13.7.4.3.1**. **Section 3.13.7.4.3.1** lists materials commonly used in manufactured home applications. Note that approved materials for building sewer pipe that are listed in the **North Carolina Plumbing Code**, current edition, but not listed in **Section 3.13.7.4.3.1**, shall also be permissible.

3.13.7.4.3.1 Building Sewer Pipe

| <u>Piping Material</u> | <u>Standard</u> |
|-------------------------|---|
| <u>ABS plastic pipe</u> | <u>ASTM D 2661; ASTM D 2751; ASTM F 628; ASTM F 1488</u> |
| <u>PVC plastic pipe</u> | <u>ASTM D 2665; ASTM D 2949; ASTM D 3034; ASTM F 891; ASTM F 1488</u> |

3.13.7.4.4 Fittings

Pipe fittings shall be approved for installation with the piping material installed and shall comply with the applicable standards listed in **Section 3.13.7.4.4.1**. **Section 3.13.7.4.4.1** lists materials commonly used in manufactured home applications. Note that approved materials for pipe fittings that are listed in the **North Carolina Plumbing Code**, current edition, but not listed in **Section 3.13.7.4.4.1**, shall also be permissible.

3.13.7.4.4.1 Pipe Fittings

| <u>Material</u> | <u>Standard</u> |
|--------------------|---|
| <u>ABS plastic</u> | <u>ASTM D 2661; ASTM D 2751; ASTM F 628</u> |
| <u>PVC plastic</u> | <u>ASTM D 2665; ASTM D 2949; ASTM D 3034; ASTM F 1866</u> |

3.13.7.5 BUILDING SEWER

3.13.7.5.1 Building Sewer Pipe Near the Water Service

Where the building sewer is installed within 5 feet of the water service, the installation shall comply with the provisions of **Section 3.13.4.2.2**.

3.13.7.5.2 Drainage Pipe in Filled Ground

Where a building sewer or building drain is installed in unstable fill or unstable ground, it shall be of cast iron pipe, except that nonmetallic drains may be laid upon an approved continuous supporting system if installed in accordance with manufacturer's installation instructions.

3.13.7.5.3 Sanitary and Storm Sewers

Where separate systems of sanitary drainage and storm drainage are installed in the same property, the sanitary and storm building sewers or drains shall be permitted to be laid side by side in one trench.

3.13.7.5.4 Existing Building Sewers and Drains

Existing building sewers and drains shall connect with new building sewer and drainage systems only where found by examination and test to conform to the new system in quality of material. The Code official shall notify the owner to make the changes necessary to conform to this Code.

3.13.7.5.5 Cleanouts on Building Sewers

Cleanouts on building sewers shall be located as set forth in **Section 3.13.7.9**.

3.13.7.5.6 Minimum Size of Building Sewer

No building sewer shall be less than 4" in size.

3.13.7.6 DRAINAGE PIPE INSTALLATION

3.13.7.6.1 Slope of Horizontal Drainage Piping

Horizontal drainage piping shall be installed in uniform alignment at uniform slopes. The minimum slope of a horizontal drainage pipe shall be in accordance with **Section 3.13.7.6.1.1**.

3.13.7.6.1.1 Slope of Horizontal Drainage Pipe

| <u>Size (inches)</u> | <u>Minimum Slope (inch per foot)</u> |
|----------------------|--------------------------------------|
| <u>2 1/2 or less</u> | <u>1/4</u> |
| <u>3 to 6</u> | <u>1/8</u> |

3.13.7.6.2 Change in Size

The size of drainage piping shall not be reduced in the direction of flow.

3.13.7.6.3 Connections to Bases of Stacks

Horizontal branches shall connect to the bases of stacks at a point located not less than 10 times the diameter of the drainage stack downstream from the stack.

3.13.7.6.4 Future Fixtures

Drainage piping for future fixtures shall terminate with an approved cap or plug.

3.13.7.6.5 Dead Ends

In the installation or removal of any part of a drainage system, dead ends shall be prohibited. Cleanout extensions and approved future fixture drainage piping shall not be considered as dead ends.

3.13.7.6.7 Minimum Size of Building Drain

The minimum size of any building drain serving a water closet shall be 3 inches.

3.13.7.7 JOINTS

3.13.7.7.1 General

This Section contains provisions applicable to joints specific to sanitary drainage piping.

3.13.7.7.2 Prohibited Joints and Connections

The following types of joints and connections shall be prohibited:

1. Mastic or hot-pour bituminous joints.
2. Joints made with fittings not approved for the specific installation.
3. Solvent-cement joints between different types of plastic pipe.
4. Joints between different diameter pipes made with elastomeric rolling O-rings.
5. Saddle-type fittings.

3.13.7.7.3 Allowable Types of Joints

The types of pipe joints listed in this Section are commonly used in manufactured housing. Joints shall be as specified in this Section, except joints listed for approved materials in the **North Carolina Plumbing Code**, current edition, that are not listed in this Section, shall be permissible.

3.13.7.7.3.1 ABS Plastic

Joints between ABS plastic pipe or fittings shall comply with **Section 3.13.7.7.3.1.1** or **3.13.7.7.3.1.2**.

3.13.7.7.3.1.1 Mechanical Joints

Mechanical joints on drainage pipes shall be made with an elastomeric seal conforming to ASTM C 1173 or ASTM D 3212. Mechanical joints shall only be installed in underground systems unless otherwise approved. Joints shall be installed in accordance with the manufacturer's instructions.

3.13.7.7.3.1.2 Solvent Cementing

Joint surfaces shall be clean and free from moisture. Solvent cement that conforms to ASTM D 2235 shall be applied to all joint surfaces. The joint shall be made while the cement is wet. Joints shall be made in accordance with ASTM D 2235, ASTM D 2661, or ASTM F 628. Solvent cement joints shall be permitted above or below ground.

3.13.7.7.3.2 PVC Plastic

Joints between PVC plastic pipe or fittings shall comply with **Section 3.13.7.7.3.2.1** or **3.13.7.7.3.2.2**.

3.13.7.7.3.2.1 Mechanical Joints

Mechanical joints on drainage pipe shall be made with an elastomeric seal conforming to ASTM C 1173 or ASTM D 3212. Mechanical joints shall not be installed in above-ground systems unless otherwise approved. Joints shall be installed in accordance with the manufacturer's instructions.

3.13.7.7.3.2.2 Solvent Cementing

Joint surfaces shall be clean and free from moisture. A purple primer or an ultraviolet purple primer that conforms to ASTM F 656 shall be applied. When an ultraviolet primer is used, the installer shall provide an ultraviolet light to the inspector to be used during the inspection. Solvent cement not purple in color and conforming to ASTM D 2564 shall be applied to all joint surfaces. The joint shall be made while the cement is wet and shall be in accordance with ASTM D 2855. Solvent cement joints shall be permitted above or below ground.

3.13.7.7.3.3 Joints Between Different Materials

Joints between different piping materials shall be made with a mechanical joint of the compression or mechanical sealing type conforming to ASTM C 1173, ASTM C 1460 or ASTM C 1461. Connectors or adapters shall be approved for the application and such joints shall have an elastomeric seal conforming to ASTM C 425, ASTM C 443, ASTM C 564, ASTM C 1440, ASTM D 1869, ASTM F 447, or as required in **Section 3.13.7.7.3.3.1**. Joints shall be installed in accordance with the manufacturer’s instructions.

3.13.7.7.3.3.1 Plastic Pipe or Tubing to Other Piping Material

Joints between different grades of plastic pipe or between plastic pipe and other piping material shall be made with an approved adapter fitting. Joints between plastic pipe and cast-iron hub pipe shall be made by a caulked joint or a mechanical compression joint.

3.13.7.8 CONNECTIONS BETWEEN DRAINAGE PIPE AND FITTINGS

3.13.7.8.1 Connections and Changes in Direction

All connections and changes in direction of the sanitary drainage system shall be made with approved drainage fittings.

3.13.7.8.2 Obstructions

The fittings shall not have ledges, shoulders or reductions capable of retarding or obstructing flow in the piping.

3.13.7.8.3 Installation of Fittings

Fittings shall be installed to guide sewage and waste in the direction of flow. Change in direction shall be made by fittings installed in accordance with **Section 3.13.7.8.3.1**. Change in direction by combination fittings, side inlets or increasers shall be installed in accordance with **Section 3.13.7.8.3.1** based on the pattern of flow created by the fitting. Double sanitary tee patterns shall not receive the discharge of back-to-back appliances with pumping action discharge.

3.13.7.8.3.1 FITTINGS FOR CHANGE IN DIRECTION (X -- Permitted)

| TYPE OF FITTING PATTERN | CHANGE IN DIRECTION | | |
|--|---------------------|-----------------------------|---------------------------|
| | Vertical | Horizontal to Horizontal | Vertical to Horizontal |
| Sixteenth Bend | | X | X |
| Eighth Bend | | X | X |
| Sixth Bend | | X | X |
| Quarter Bend | | X | X ^{d, f} |
| Short Sweep | | X | X ^b |
| Long Sweep | | X | X |
| Sanitary Tee | | X ^c | |
| Wye | | X | X |
| Combination Wye and Eighth Bend | | X | X |

- a. The fittings shall only be permitted for a 2-inch or smaller sink or lavatory fixture drain.
- b. Two inches or larger.
- c. For a limitation on double sanitary tees, see **Section 3.13.7.8.3**.
- d. May be used only within 12 inches below water closet flange measured to centerline of the quarter bend.
- e. This fitting shall only be permitted to be used as the first fitting directly behind the fixture for drains 2 inches and smaller, except clothes washers.
- f. The heel inlet connection of a quarter bend may be used as a wet or dry vent if the heel inlet connection of the quarter bend is located in the vertical position. The heel of side inlet connection may be used as a wet vent if the quarter bend is located directly below a water closet or other fixture with one integral trap.

3.13.7.9 CLEANOUTS

3.13.7.9.1 Scope

This section shall govern the size, location, installation and maintenance of gravity drainage pipe cleanouts.

3.13.7.9.2 Cleanout Plugs

Cleanout plugs shall be plastic or shall be of other materials permitted in the **North Carolina Plumbing Code**, current edition. Plastic cleanout plugs shall conform to the requirements of **Section 3.13.7.4.4**. Plugs shall have raised square or countersunk square heads. Countersunk heads shall be installed where raised heads are a trip hazard.

3.13.7.9.3 Where Required

Cleanouts shall be located in accordance with the following:

1. Horizontal Drains within Buildings.

All horizontal drains shall be provided with cleanouts located not more than 100 feet apart.

2. Gravity Building Sewers

Building Sewers shall be provided with cleanouts located not more than 100 feet apart measured from the upstream entrance of the cleanout.

3. Changes in Direction

One cleanout shall be required for every four horizontal 45 degree changes located in series. (A long sweep is equivalent to two 45 degree bends.)

4. Base of Stack

A cleanout shall be provided at the base of each waste or soil stack.

5. Building Drain and Building Sewer Junction

There shall be a cleanout at the junction of the building drain and the building sewer. The cleanout shall be outside the building wall and shall be brought up to the finished ground level. An approved two-way cleanout is allowed to be used at this location to serve as a required cleanout for both the building drain and building sewer. The cleanout at the junction of the building drain and building sewer shall not be required if the cleanout on a 3 inch or larger diameter soil stack is located within a developed length of not more than 15 feet of the building drain and building sewer connection and is extended to the outside of the building. The minimum size of the cleanout at the junction of the building drain and building sewer shall comply with **Section 3.13.7.9.7**.

3.13.7.9.4 Concealed Piping

Cleanouts on concealed piping or piping under a floor slab or in a crawl space of less than 24 inches in height or a plenum shall be extended through and terminate flush with the finished wall, floor or ground surface or shall be extended to the outside of the building. Cleanout plugs shall not be covered with cement, plaster or any other permanent finish material. Where it is necessary to conceal a cleanout or to terminate a cleanout in an area subject to vehicular traffic, the covering plate, access door or cleanout shall be of an approved type designed and installed for this purpose.

3.13.7.9.5 Opening Direction

Every cleanout shall be installed to open to allow cleaning in the direction of the flow of the drainage pipe or at right angles thereto.

3.13.7.9.6 Prohibited Installation

Cleanout openings shall not be utilized for the installation of new fixtures, except where approved and where another cleanout of equal access and capacity is provided.

3.13.7.9.7 Minimum Size

Cleanouts shall be the same nominal size as the pipe they serve up to 4 inches. For pipes larger than 4 inches nominal size, the minimum size of the cleanout shall be 4 inches.

3.13.7.9.8 Clearances

Cleanouts on 6 inch and smaller pipes shall be provided with a clearance of not less than 18 inches for rodding. Cleanouts on 8 inch and larger pipes shall be provided with a clearance of not less than 36 inches for rodding.

3.13.7.9.9 Access

Access shall be provided to all cleanouts.

3.13.7.10 BACKWATER VALVES

3.13.7.10.1 Sewage Backflow

Where the flood level rims of plumbing fixtures are below the elevation of the manhole cover of the next upstream manhole in the public sewer, such fixtures shall be protected by a backwater valve installed in the building drain, branch of the building drain or horizontal branch serving such fixtures. Plumbing fixtures having flood level rims above the elevation of the manhole cover of the next upstream manhole in the public sewer shall not discharge through a backwater valve.

3.13.7.10.2 Material

All bearing parts of backwater valves shall be of corrosion-resistant material. Backwater valves shall comply with ASME A112.14.1.

3.13.7.10.3 Seal

Backwater valves shall be so constructed as to provide a mechanical seal against backflow.

3.13.7.10.4 Diameter

Backwater valves, when fully opened, shall have a capacity not less than that of the pipes in which they are installed.

3.13.7.10.5 Location

Backwater valves shall be installed so that access is provided to the working parts for service and repair.

3.14 MECHANICAL REQUIREMENTS

3.14.1 Mechanical Requirements – General

Factory installed mechanical systems or equipment are not subject to this Code. Field installed equipment shall be installed in accordance with the equipment manufacturer's installation instructions. Field installed attachments shall be listed as being compatible with existing equipment and shall be installed in accordance with the equipment manufacturer's installation instructions.

3.14.2 Fuel Gas Systems

Manufactured homes may be designed for a natural gas supply, liquefied petroleum gas supply, or both. The manufacturer is required to identify the approved fuel for which the system is designed. The approved fuel is generally identified at the gas inlet.

3.14.2.1 Fuel Gas Piping

Gas piping systems for each unit are usually shipped complete from the factory and require only that connections to the supply and connections between adjacent units be made at the site. Installation shall be in accordance with the following:

3.14.2.1.1 Crossover Connection.

The crossover is commonly a flexible connector located at the mate line of adjacent units. The connection shall be the same size as the connected gas piping and the type of connector used shall comply with the Manufacturer's Installation Instructions. Additional crossover connector ducts are not to be installed in the field unless the DAPIA approved duct system has been redesigned and reapproved by the DAPIA. Installation of additional crossover ducts must be permitted, approved, and inspected by the local mechanical inspector.

3.14.2.1.2 Tank Location.

Installers and inspection personnel shall ensure that fuel supply tanks are located in accordance with the Manufacturer's Installation Instructions and local requirements regarding fire separation and clearances.

3.14.2.1.3 Shutoff Valves

A listed gas shutoff valve shall be installed upstream of the manufactured home gas outlet. This valve shall not be located under the manufactured home.

3.14.2.1.4 Fuel Gas Supply Materials And Support

All site-installed fuel gas piping and joint materials and installation of same shall be in accordance with the Manufacturer's Installation Instructions. Gas appliance orifices shall be checked for the type of fuel used. Note that the orifice size may be influenced by the elevation of the home above sea level. Elevations above 3000' will generally require a special orifice size. Installers and inspection personnel shall ensure that field installed gas piping is supported according to the manufacturer's installation instructions. Federal Standards require that piping be supported by metal straps or hangers at intervals of not more than 4 feet except where adequate support and protection is provided by structural members.

3.14.2.1.5 Electrical Ground

Fuel gas piping shall not be used for an electrical ground.

3.14.2.1.6 Fuel Gas Supply Piping Tests

Although Federal Standards require that fuel gas piping be tested at the factory, the Manufacturer's Installation Instructions may require that the gas piping also be tested at the site. Fuel gas piping tests, when required, shall be carried out as follows, subject to specific procedures in the Manufacturer's Installation Instructions:

High Pressure Gas Test

1. Close all shutoff valves at each outlet. If valves are not installed, verify that each outlet is capped.
2. Pressurize the piping system to 3 psi gage (6 inch mercury column).
3. Isolate the pressure source and hold pressure in the system for 10 minutes without any loss.
4. Failure to maintain pressure requires that the system be repaired and retested.

Low Pressure Gas Test

1. Open all shutoff valves at each appliance. (The typical valve is open when the handle is parallel to the length of the pipe.)
2. Close all shutoff valves that are integral to the appliance (not the in-line valves). Turn all appliance lights off, if possible. If the pilot lights are not turned off, air will leak through the open pilots when pressure is applied to the system. For this reason, a regulator is required to provide a continuous flow of air.
3. Pressurize the system to a 10" to 14" water column.
(Note: A 10 inch water column is approximately 0.36 psi, or approximately a 3/4 inch mercury column)
4. Check all appliance connections with a soapy solution. Bubbling will occur if there is a leak.
5. If leaks are detected, repair and retest the system.

3.14.3 Unvented Gas-Fired Heaters in Manufactured Homes

In accordance with NC General Statute § 119-58, all unvented Liquefied Petroleum (LP) and Non-Liquefied Petroleum (Non-LP) gas-fired heaters installed in manufactured homes shall be accepted in accordance with the following:

1. All unvented room heaters shall be installed in accordance with the requirements of the North Carolina Fuel Gas Code (current edition).
2. All unvented room heaters shall be listed and labeled for installation in a manufactured home.
3. All unvented room heaters shall be installed in accordance with the conditions of its listing and the manufacturer's installation instructions.

3.14.4 Prefabricated Fireplace Units in Manufactured Homes

Section §3280.709(g)(1)(ii) of the HUD publication Part 3280, Manufactured Home Construction and Safety Standards, states:

A fireplace or fireplace stove, air intake assembly, hearth extension and the chimney shall be installed in accordance with the terms of their listings and their manufacturer's instructions.

§3280.709(g)(1)(vii) states:

The chimney shall extend at least three feet above the part of the roof through which it passes and at least two feet above the highest elevation of any part of the manufactured home within 10 feet of the chimney. Portions of the chimney and termination that exceed an elevation of 13 1/2 ft. above ground level may be designed to be removed for transporting the manufactured home.

Fireplace units shall be installed strictly in accordance with "the terms of their listings and their manufacturer's instructions". This shall include any *completion* of the installation which is done at the site. Manufacturers must insure that sufficient length of chimney is furnished such that the vertical clearances described above are met or exceeded.

All fireplaces and wood stoves installed shall be listed for use in manufactured housing. For field installation, approval shall be required from the manufacturer and the authority having jurisdiction to assure compliance to the required standards.

3.14.4.1 Flue and Spark Arrester Installation

Manufactured homes are permitted to be shipped without flue and spark arrester assemblies completed, provided the manufacturer includes installation instructions with the home. Installers and inspection personnel shall ensure that the flue and spark arrester assemblies are installed in accordance with the Manufacturer's Installation Instructions, with attention to the following:

1. Removal of the protective covering shipped with the unit.
2. Proper clearances of adjacent construction and proper height above appliance/roof.
3. Proper weatherproofing.
4. Securement of components.

3.14.5 Prefabricated Fireplace Units with Gas Logs

It is acceptable to install a prefabricated fireplace unit with gas logs in an existing manufactured home subject to the following:

1. The fireplace unit must be listed for use in a manufactured home and must be listed to receive vented gas logs.
2. The vent must remain open.
3. The gas logs must be of the vented type, listed to be used in a vented fireplace.

The unit must be installed in strict accordance with the manufacturer's instructions, including proper elevation of the chimney termination.

3.14.6 Oil Piping Systems

Oil piping systems are usually not completed at the factory. The requirements of this Section shall apply to the installation of all liquid fuel piping attached to any manufactured home. None of the requirements in this Section shall apply to the piping in the appliance(s). Installers and inspection personnel shall insure that the system complies with the following:

3.14.6.1 Oil Tanks

Fuel supply tanks shall be installed in accordance with the Manufacturer's Installation Instructions and **Chapter 13, North Carolina Mechanical Code**, current edition.

3.14.6.2 Shutoff Valves

A readily accessible manual shutoff valve shall be installed between the oil supply tank and the burner. If the shutoff valve is installed in the discharge line of an oil pump, a pressure relief valve shall be incorporated to bypass or return surplus oil.

3.14.6.3 Oil Piping Materials

All materials used for the installation, extension, alteration, or repair of any oil piping system shall be new and free from defects or internal obstructions. The system shall be made of materials having a melting point of not less than 1450° F, except as provided in **Sections 3.14.6.5 and 3.14.6.6**. Piping and fittings shall consist of one or more of the materials listed in items 1 through 4 below:

1. Steel pipe or tubing shall comply with ASTM A 53, ASTM A 106, ASTM A 254, or ASTM A539. Threaded copper or brass pipe in iron pipe sizes may be used.
2. Fittings and valves shall be approved for the piping systems, and shall be compatible with, or shall be of the same material as, the piping or tubing.
3. Copper tubing shall be annealed type, Grade K or L, conforming to the Standard Specification for Seamless Water Tube, ASTM B88, or shall comply with the Standard Specification for Seamless Copper Tube for Air Conditioning and Refrigeration Field Service, ASTM B280.
4. Steel tubing shall have a minimum wall thickness of 0.032 inches for diameters up to 1/2 inch and 0.049 inches for diameters of 1/2 inch and larger. Steel tubing shall be constructed in accordance with the Specification for Electric-Resistance-Welded Coiled Steel Tubing for Gas and Field Oil Lines, ASTM, A539, and shall be externally corrosion protected.

3.14.6.4 Size of Oil Piping

The minimum size of all fuel oil tank piping connecting outside tanks to the appliance shall be no smaller than 3/8" OD copper tubing or 1/4" IPS (International Pipe Standard). If No. 1 fuel oil is used with a listed automatic pump (fuel lifter), copper tubing shall be sized as specified by the pump manufacturer.

3.14.6.5 Joints for Oil Piping

All pipe joints in the piping system, unless welded or brazed, shall be threaded joints which comply with ASME B1.20.1, Pipe Threads, General Purpose (Inch). The material used for brazing pipe connections shall have a melting temperature in excess of 1,000° F.

3.14.6.6 Joints for Tubing

Joints in tubing shall be made with either a single or double flare of the proper degree, as recommended by the tubing manufacturer, by means of listed tubing fittings, or brazed with materials having a melting point in excess of 1,000° F.

3.14.6.7 Pipe Joint Compound

Threaded joints shall be made up tight with listed pipe joint compound which shall be applied to the male threads only.

3.14.6.8 Couplings

Pipe couplings and unions shall be used to join sections of threaded pipe. Right and left nipples or couplings shall not be used.

3.14.6.9 Grade (Slope) of Piping

Fuel oil piping installed in conjunction with gravity feed systems to oil heating equipment shall slope in a gradual rise upward from a central location to both the oil tank and the appliance in order to eliminate air locks.

3.14.6.10 Strap Hangers

All oil piping shall be adequately supported by galvanized or equivalently protected metal straps or hangers at intervals of not more than 4 feet, except where adequate support and protection is provided by structural members. Solid iron pipe oil supply connection(s) shall be rigidly anchored to a structural member within 6 inches of the supply connection(s).

3.14.6.11 Testing for Leakage

Before setting the system in operation, tank installations and piping shall be checked for oil leaks with fuel oil of the same grade that will be burned in the appliance. No other material shall be used for testing fuel oil tanks and piping. Tanks shall be filled to maximum capacity for the final check for oil leakage.

3.14.7 Comfort Cooling Systems

Prior to the installation of a comfort cooling system, the home's data plate shall be checked to assure that the home has been designed for the installation of central air conditioning. Required local permits shall be obtained prior to beginning the installation. Only qualified personnel may install a comfort cooling system not provided with the home. The installation shall be in accordance with the Manufacturer's Installation Instructions and the NC State Building Code, and shall be inspected by the local inspection jurisdiction.

3.14.7.1 Air Conditioners

Installation of a central air conditioning system shall not exceed the rating shown on the home's compliance certificate. The home's electrical distribution panel may contain optional factory-installed circuits for air conditioning. The maximum full load ampere draw for the desired air conditioning unit must not exceed the circuit rating shown.

IMPORTANT: Electrical circuits within the home may not have been sized for the additional load of non-factory-installed air conditioning, and a separate, outside electrical supply may have to be provided.

"A"-coil air conditioning units shall be compatible and listed for use with the furnace in the home. Installation shall be in accordance with the air conditioner manufacturer's instructions. All condensation shall be discharged beyond the perimeter of the home by means specified by the equipment manufacturer.

3.14.7.2 Heat Pumps Heat pumps shall be installed in accordance with the heat pump manufacturer's instructions.

3.14.7.3 Evaporative Coolers

Roof-mounted coolers shall be installed in accordance with the appliance manufacturer's instructions. Before installing a roof-mounted cooler, the home manufacturer or a professional engineer or architect shall verify that the roof will support weight of the cooler. A rigid base shall be provided to evenly distribute the weight of the cooler over several rafters, subject to specific instructions from the home manufacturer or professional engineer or architect.

3.14.8 Clothes Dryer Exhaust Duct System

When a manufactured home has wiring installed for future installation of an electric clothes dryer, or has "stubbed in" equipment installed at the factory for future installation of a gas clothes dryer, Federal Standards require the home manufacturer to provide written instructions on how to complete the exhaust duct installation. When such provisions are present, the installer shall complete installation of the exhaust duct system, *whether or not the clothes dryer is present at the time of the installation*. Exhaust duct systems shall be installed in accordance with the following, subject to specific procedures in the Manufacturer's Installation Instructions (NOTE: Lint and dust accumulation can ignite, causing a fire.)

3.14.8.1 Clothes Dryer Exhaust Duct Systems – General

Dry vent systems shall be independent of all other systems and shall be equipped with a backdraft damper. *The exhaust duct shall not contain reverse slope or terminate beneath the home.* Screens shall not be installed at the duct termination. Ducts shall not be connected or installed with sheet-metal screws or other fasteners that will obstruct the exhaust flow. Clothes dryer exhaust ducts shall not be connected to a vent connector, vent or chimney. Clothes dryer exhaust ducts shall not extend into or through ducts or chimneys.

3.14.8.2 Exhaust Duct Material and Size

Exhaust ducts shall have a smooth interior finish and shall be constructed of metal a minimum 0.016 inch thick. With the exception of the transition duct, flexible ducts are prohibited. The exhaust duct size shall be 4 inches nominal in diameter.

3.14.8.3 Transition Ducts

Transition ducts used to connect the dryer to the exhaust duct system shall be a single length that is listed and labeled in accordance with UL 2158A. Transition ducts shall be a maximum of 8 feet in length, shall not be concealed within construction, and must remain entirely within the room in which the appliance is installed.

3.14.8.4 Length Limitation

The maximum allowable exhaust duct length shall be determined by one of the methods specified in **Section 3.14.8.4.1** or **3.18.8.4.2**.

3.14.8.4.1 Specified Length

The maximum length of the exhaust duct shall be 35 feet from the connection to the transition duct from the dryer to the outlet terminal. Where fittings are used, the maximum length of the exhaust duct shall be reduced as specified in **Section 504, North Carolina Mechanical Code**, current edition.

3.14.8.4.2 Manufacturer's Instructions

The maximum length of the exhaust duct shall be determined by the dryer manufacturer's installation instructions. The Code official shall be provided with a copy of the installation instructions for the make and model of the dryer. Where the exhaust duct is to be concealed, the installation instructions shall be provided to the Code official prior to the concealment inspection. In the absence of fitting equivalent length calculations from the clothes dryer manufacturer, the specified reductions in **Section 504, North Carolina Mechanical Code**, current edition, shall be used.

3.14.8.5 Duct Installation and Termination

Exhaust ducts shall be supported at 4-foot intervals and secured in place and shall terminate not less than 12 inches above finished grade. The insert end of the duct shall extend into the adjoining duct or fitting in the direction of airflow. Ducts shall not be joined with screws or similar fasteners that protrude into the inside of the duct.

3.14.9 Crossover Air-Handling Ducts

Regarding the field installation of crossover air-handling ducts for multi-section manufactured homes, the following are the minimum acceptable procedures, subject to specific requirements in the Manufacturer's Installation Instructions, if applicable (see **Section 1.3.1**):

3.14.9.1 Connection of Flexible Duct to Duct Collars and V-box Adapters

1. Pull back jacket and insulation from core. Slide exposed end over duct collar and up against bottom board material or V-box.
2. Tape core with at least two (2) wraps of duct tape. Note that tape must comply with *UL 181B* listing and must be marked "*181B-FX*".
3. Fasten duct to collar with three (3) sheet metal screws through the tape installed per item 2 above, equally spaced around collar. Screws should be in lower part of collar.
4. Pull jacket and insulation back over core and secure with at least two (2) wraps of duct tape as specified above.
5. Add metal screw clamp or plastic tie around collar over the tape and above the screws described in item 2 above. Secure tightly.

3.14.9.2 Procedure for Duct Splices

1. Peel back jacket and insulation from core. Butt the two cores together on a minimum 4" sleeve.
2. Tape the cores together with at least two (2) wraps of UL 181B duct tape.
3. Install two (2) metal screw clamps or plastic ties over the tape (one over each core end) and secure tightly.
4. Pull jacket and insulation back over cores. Tape jackets together with at least two (2) wraps of duct tape as specified above.

3.14.9.3 Support of Flexible Duct

1. Hanger supports shall be provided within 1 foot of collar or V-box connection and then at intervals not exceeding 4 feet.
2. When installing duct, excess length must be trimmed such that no more than 1/2" of sag per foot of duct occurs between supports. With 4 ft. support spacing, this would allow no more than 2" of sag between supports.
3. Hangers shall be installed such that at least 4" of clearance is maintained between the bottom of the duct and the ground. *Note that this ground clearance must be obtained by hanger supports and not by resting the duct on blocks of any kind.*
4. Hanger material in contact with the flexible duct shall be of sufficient width to prevent any restriction of the internal diameter of the duct when the weight of the supported section rests on the hanger material. When straps are used to support a flexible type duct, the straps must be at least 1/2" wider than the spacing of the metal spirals encasing the duct. The ducts must be installed such that the straps cannot slip between any two spirals and arranged under the floor to prevent compression. *The material contacting the duct must not be less than 1 1/2" wide.*
5. On the outrigger side of the I-beams, the straps can be stapled directly through the bottom board into the underside of a floor joist. Between I-beams, the strap should be supported by steel cross members or by floor joists if the joists are accessible without damaging the bottom board. *Under no circumstances should the bottom board be cut between the I-beams.*
6. When using webbing strap to support, the strap should be folded for two or three thicknesses before applying the fastener. The fastener for attaching to underside of floor joists should be screws, roofing nails, or staples. Attachment to steel cross members should be with self-tapping screws.
7. Other methods of support may be accepted by the local jurisdiction so long as the criteria above is adhered to as a minimum.

3.14.9.4 Sufficient Length of Flexible Duct

It shall be the responsibility of the manufacturer to ensure that an adequate length of duct material is provided to make the crossover connection(s).

3.14.9.5 Additional Crossover Air-Handling Ducts

Additional crossover air-handling ducts shall not be installed unless designed by the home manufacturer or a North Carolina registered engineer, and shall be inspected by the local Building Official.

3.15 MANUFACTURED HOMES LOCATED IN FLOOD HAZARD AREAS

3.15.1 General

In accordance with § 143-138(e), *Local floodplain regulations may regulate all types and uses of buildings or structures located in flood hazard areas identified by local, State, and federal agencies, and include provisions governing substantial improvements, substantial damage, cumulative substantial improvements, lowest floor elevation, protection of mechanical and electrical systems, foundation construction, anchorage, acceptable flood resistant materials, and other measures the political subdivision deems necessary considering the characteristics of its flood hazards and vulnerability.*

In the absence of more stringent local regulations, the provisions of **Section 3.15** shall govern the installation of manufactured homes in flood hazard areas. Within flood hazard areas as established in **Section 3.15.3**, all installations of manufactured homes, including substantial improvements and restoration of substantial damage to the same, shall be designed, connected and anchored to resist flotation, collapse, or permanent lateral movement due to structural loads and stresses from flooding equal to the Design Flood Elevation. Site-built additions or alterations to manufactured homes in Coastal High Hazard and Ocean High Hazard Areas shall be further subject to the requirements of **Section 3.15.8**.

3.15.2 Definitions

ASCE 24 -- American Society of Civil Engineers Standard, *Flood Resistant Design and Construction*. The Edition of ASCE 24 currently listed in the NC Building Code, 2002 Edition, is ASCE 24-98.

BASE FLOOD ELEVATION -- The elevation of the base flood, including wave height, relative to the National Geodetic Vertical Datum (NGVD), North American Vertical Datum (NAVD) or other datum specified on the flood insurance rate map (FIRM).

COASTAL HIGH HAZARD AREA -- An area subject to coastal flooding and high velocity waters including storm wave wash, as shown by Federal Emergency Management Agency Maps and subject to the approval of the Building Code Council.

OCEAN HIGH HAZARD AREA -- An area, as identified by the North Carolina Coastal Resources Commission, and subject to approval by the Building Code Council, near the shoreline of the Atlantic Ocean which has been identified as subject to at least one of the following hazards: (A) Historical or predicted future trends of long term erosion, (B) erosion expected to occur during a coastal storm reaching the base flood elevation, or (C) shoreline fluctuations due to tidal inlets.

DESIGN FLOOD -- The flood associated with the greater of the following two areas:

1. Area within a floodplain subject to a 1 percent or greater chance of flooding in any year; or
2. Area designated as a flood hazard area on a community's flood hazard map, or otherwise legally designated.

DESIGN FLOOD ELEVATION -- The elevation of the "design flood", including wave height, relative to the datum specified on the community's legally designated flood hazard map.

FLOOD DAMAGE RESISTANT MATERIALS -- Any construction material capable of withstanding direct and prolonged contact with floodwaters without sustaining any damage that requires more than cosmetic repair.

FLOOD HAZARD AREA -- The greater of the following two areas:

1. Area within a floodplain subject to a 1 percent or greater chance of flooding in any year.
2. Area designated as a flood hazard area on a community's flood hazard map, or otherwise legally designated.

FLOOD HAZARD AREA SUBJECT TO HIGH VELOCITY WAVE ACTION -- Area within the flood hazard area that is subject to high velocity wave action, and shown on a Flood Insurance Rate Map (FIRM) or other flood hazard map as Zone V, VO, or V1-V30.

FLOOD INSURANCE RATE MAP (FIRM) -- An official map of a community on which the Federal Emergency Management Agency has delineated both the special flood hazard areas and the risk premium zones applicable to the community.

FLOOD INSURANCE ZONES -- The insurance zone designations shown on Flood Insurance Rate Maps (FIRMs) that indicate the magnitude and severity of flood hazards. The zone designations that apply to coastal and non-coastal flood hazard areas are listed below, in decreasing order of magnitude and severity.

ZONES VE, V1-V30, and V -- These zones, collectively referred to as "V zones", identify the Coastal High Hazard Area, which is the portion of the Special Flood Hazard Area that extends from offshore to the inland limit of a primary frontal dune along an open coast and any other portion of the Special Flood Hazard Area that is subject to high-velocity wave action from storms or seismic sources. V zones are generally based on wave heights or wave runup depths of 3 feet or greater.

ZONES AE, A1-A30, AO, and A -- These zones, collectively referred to as "A zones", identify portions of the Special Flood Hazard Area that are not within the Coastal High Hazard Area. Flood Insurance Rate Maps (FIRMs) use Zone AE, A1-A30, AO, and A to designate both coastal and non-coastal Special Flood Hazard Areas. Regulatory requirements are the same for buildings in coastal and non-coastal A zones. Buildings in coastal A zones may be subject to breaking waves heights or wave runup depths less than 3 feet.

ZONES X, B, and C -- These zones identify areas outside the Special Flood Hazard Area. Zone B and shaded Zone X identify areas subject to inundation by the flood that has a 0.2 percent probability of being equaled or exceeded during any given year, often referred to as the 500-year flood. Zones C and unshaded Zone X identify areas above the level of the 500-year flood.

FREEBOARD -- A factor of safety usually expressed in feet above a flood level for purposes of floodplain management. Used to compensate for the many unknown factors that could contribute to flood heights greater than the height calculated for a selected size flood and floodway conditions, such as wave action, bridge openings, and the hydrological effect of urbanization of the watershed.

LOWEST FLOOR -- The floor of the lowest enclosed area, including basement, but excluding any unfinished or flood-resistant enclosure, usable solely for vehicle parking, building access, or limited storage provided that such enclosure is not built so as to render the structure in violation of **Section 3.15**.

SPECIAL FLOOD HAZARD AREA -- The land area subject to flood hazards and shown on a Flood Insurance Rate Map (FIRM) or other flood hazard map as Zone A, AE, A1-A30, A99, AR, AO, AH, V, VO, VE, or V1-V30.

SUBSTANTIAL DAMAGE -- Damage of any origin sustained by a structure whereby the cost of restoring the structure to its before damaged condition would equal or exceed 50 percent of the market value of the structure before damage occurred.

SUBSTANTIAL IMPROVEMENT -- Any repair, reconstruction, rehabilitation, addition, or improvement of a building or structure, the cost of which equals or exceeds 50 percent of the market value of the structure before the improvement or repair is started. If the structure has sustained substantial damage, any repairs are considered substantial improvement regardless of the actual repair work performed. The term does not, however, include any project for improvement of a building required to correct existing health, sanitary or safety code violations identified by the building official and that are the minimum necessary to assure safe living conditions.

3.15.3 Establishment of Flood Hazard Areas

To establish flood hazard areas, the governing body shall adopt a flood hazard map and supporting data. The flood hazard map shall include, at a minimum, areas of special flood hazard as identified by the Federal Emergency Management Agency in an engineering report entitled "The Flood Insurance Study for [*insert name of jurisdiction*]", dated [*insert date of issuance*], as amended or revised with the accompanying Flood Insurance Rate Map (FIRM) and Flood Boundary Floodway Map (FBFM) and related supporting data along with any revisions thereto. The adopted flood hazard map and supporting data are hereby adopted by reference and declared to be part of this Section.

3.15.4 Elevation Requirements

3.15.4.1 FLOOD HAZARD AREAS NOT SUBJECT TO HIGH VELOCITY WAVE ACTION

The bottom of the chassis for all new or used manufactured homes to be placed in flood hazard areas not subject to high velocity wave action shall be elevated above the Design Flood Elevation. In areas of shallow flooding (AO Zones), the bottom of the chassis shall be elevated at least as high above the highest adjacent grade as the depth number specified in feet on the Flood Insurance Rate Map (FIRM), or at least 2 feet if a depth number is not specified.

3.15.4.2 FLOOD HAZARD AREAS SUBJECT TO HIGH VELOCITY WAVE ACTION

For all new or used manufactured homes to be placed in flood hazard areas subject to high velocity wave action, if the main I-beams are oriented parallel to the direction of wave approach, the bottom of the chassis shall be elevated above the Design Flood Elevation.

If the main I-beams are oriented perpendicular to the direction of wave approach, the bottom of the chassis shall be elevated at the Base Flood Elevation + 1 ft., or above the Design Flood Elevation, whichever is greater.

For the purposes of this Section, *parallel* shall mean that the main I-beams are oriented less than or equal to $\pm 20^\circ$ from the direction of wave approach. *Perpendicular* shall mean that the main I-beams are oriented greater than $\pm 20^\circ$ from the direction of wave approach.

3.15.5 Foundation Design and Construction

For all new or used manufactured homes to be placed in flood hazard areas *not subject to high velocity wave action*, and with Design Flood Elevations of 66" or less above grade, the engineered design given in Appendix B may be used, except that the base of the footers shall be not less than 2 feet below grade to provide lateral stability and to resist scour by flood waters. Use of the system in Appendix B shall also be subject to the requirements of **Section 3.15.6.1**.

The foundation design and construction for all new or used manufactured homes to be placed in flood hazard areas *subject to high velocity wave action* or with Design Flood Elevations *greater than 66" above grade* shall be in accordance with **Section 3.15.6.2**.

3.15.6 Flood Hazard Certificates

The following certificates shall be submitted to the local building official:

3.15.6.1 Homes in Flood Hazard Areas Not Subject to High Velocity Wave Action

1. A North Carolina registered land surveyor, engineer, or architect shall certify that the bottom of the chassis is in compliance with the elevation requirements of **Section 3.15.4.1**.
2. Where the requirements given in items **a** through **f** below are NOT met, certification by a North Carolina registered engineer or architect that the design will provide for equalization of hydrostatic flood forces in accordance with **Section 2.6.1.2, ASCE 24**, shall be required.

For fully enclosed areas below the Design Flood Elevation, non-engineered provisions to allow for the automatic entry and exit of floodwaters may be accomplished as follows:

- a. There shall be a minimum of two openings on different sides of each enclosed area. If a structure has more than one enclosed area below the Design Flood Elevation, each area shall have openings on exterior walls.
- b. The total net area of all openings shall be at least 1 square inch for each square foot of enclosed area.
- c. The bottom of each opening shall be no more than 1 ft. above the adjacent ground level.
- d. Openings shall not be less than 3 inches in diameter.
- e. Any louvers, screens or other opening covers shall not block or impede the automatic flow of floodwaters into and out of the enclosed areas.
- f. Openings meeting requirements **a** through **e** above that are installed in doors or windows are acceptable. However, doors and windows alone are not deemed to meet these requirements.

3.15.6.2 Homes in Flood Hazard Areas Subject to High Velocity Wave Action

1. A North Carolina registered land surveyor, engineer, or architect shall certify that the bottom of the chassis is in compliance with the elevation requirements of **Section 3.15.4.2**.
2. A certificate prepared by a North Carolina registered engineer or architect that the foundation is designed in accordance with **ASCE 24**, including that the pile or column foundation and home attached thereto is anchored to resist flotation, collapse, and lateral movement due to the effects of wind and flood loads acting simultaneously on all building components.
3. Walls and partitions are permitted below the Design Flood Elevation provided that such walls and partitions are not part of the structural support of the home and:
 - a. Are constructed with insect screening or open lattice.
 - b. Are designed to break away or collapse without causing collapse, displacement or other structural damage to the elevated portion of the home or supporting foundation system. Such walls, framing and connections shall have a design safe loading resistance of not less than 10 psf and no more than 20 psf (Wind Zone I), and shall be certified accordingly by a North Carolina registered engineer or architect.
 - c. In Wind Zones II and III, a North Carolina registered engineer or architect shall certify the following:
 - i. Collapse of walls and partitions below the Design Flood Elevation shall result from a water load less than that which would occur during the Design Flood.
 - ii. The elevated portion of the home and supporting foundation system shall not be subject to collapse, displacement, or other structural damage due to the effects of wind and flood loads acting simultaneously on all components of the home (structural and non-structural). Water loading values used shall be those associated with the Design Flood. Wind loading values shall be in accordance with the applicable Wind Zone as given in **Section 3.4.1** of this Code.
 - d. Enclosed areas below the Design Flood Elevation shall be used solely for parking of vehicles, building access, or storage.

3.15.7 Resistance to Weather Deterioration

All anchoring equipment, tension devices, and ties for homes located in flood hazard areas shall be considered as exposed to weathering and shall meet the requirements of **Section 3.9.3.2** of this Code.

3.15.8 Corrosion Resistance Requirements in Coastal and Ocean High Hazard Areas

Site-built additions or alterations to manufactured homes in Coastal High Hazard and Ocean High Hazard Areas shall be subject to the following requirements:

Hardware in open areas (exterior, porches, or underhouse) and enclosed crawlspaces in Coastal and Ocean High Hazard Areas shall conform to the following:

1. Nails, staples, screws, nuts, bolts, washers, and tie rods shall be hot dipped galvanized.
2. Steel connection plates shall be a minimum of 3/16" in thickness and shall be hot dipped galvanized after fabrication in open areas and hot dipped galvanized in enclosed crawlspaces.
3. Sheet metal connectors, joists, hangers, steel joists and beams shall be stainless steel or hot dipped galvanized after fabrication.

Note that the above requirements *shall not* apply to the factory produced portion of the home, which has been HUD certified.

3.15.9 Protection of Mechanical, Plumbing, and Electrical Systems

3.15.9.1 Mechanical Systems

New and replacement, heating, ventilating, air conditioning, and other mechanical equipment shall be located at or above the Design Flood Elevation. Duct systems shall not be installed below the Design Flood Elevation.

EXCEPTION: Crossover ducts below the bottom of the chassis in multi-section homes may extend below the Design Flood Elevation.

3.15.9.2 Plumbing Systems

New and replacement water supply systems shall be designed to minimize infiltration of flood waters into the systems. New and replacement sanitary sewage systems shall be designed to minimize infiltration of flood waters into the systems and discharges from systems into flood waters.

3.15.9.3 Electrical Systems

New and replacement electrical equipment shall be located at or above the Design Flood Elevation. Electrical wiring and outlets, switches, junction boxes and panels shall be elevated to or above the Design Flood Elevation unless they conform to the provisions of the **NC Electrical Code**, current edition, for location of such items in wet locations.

APPENDIX A

ELEVATED / FLOOD HAZARD FOUNDATION DESIGN

NOTE: Appendix A foundations used in Flood Hazard areas shall also comply with Section 3.15, MANUFACTURED HOMES LOCATED IN FLOOD HAZARD AREAS

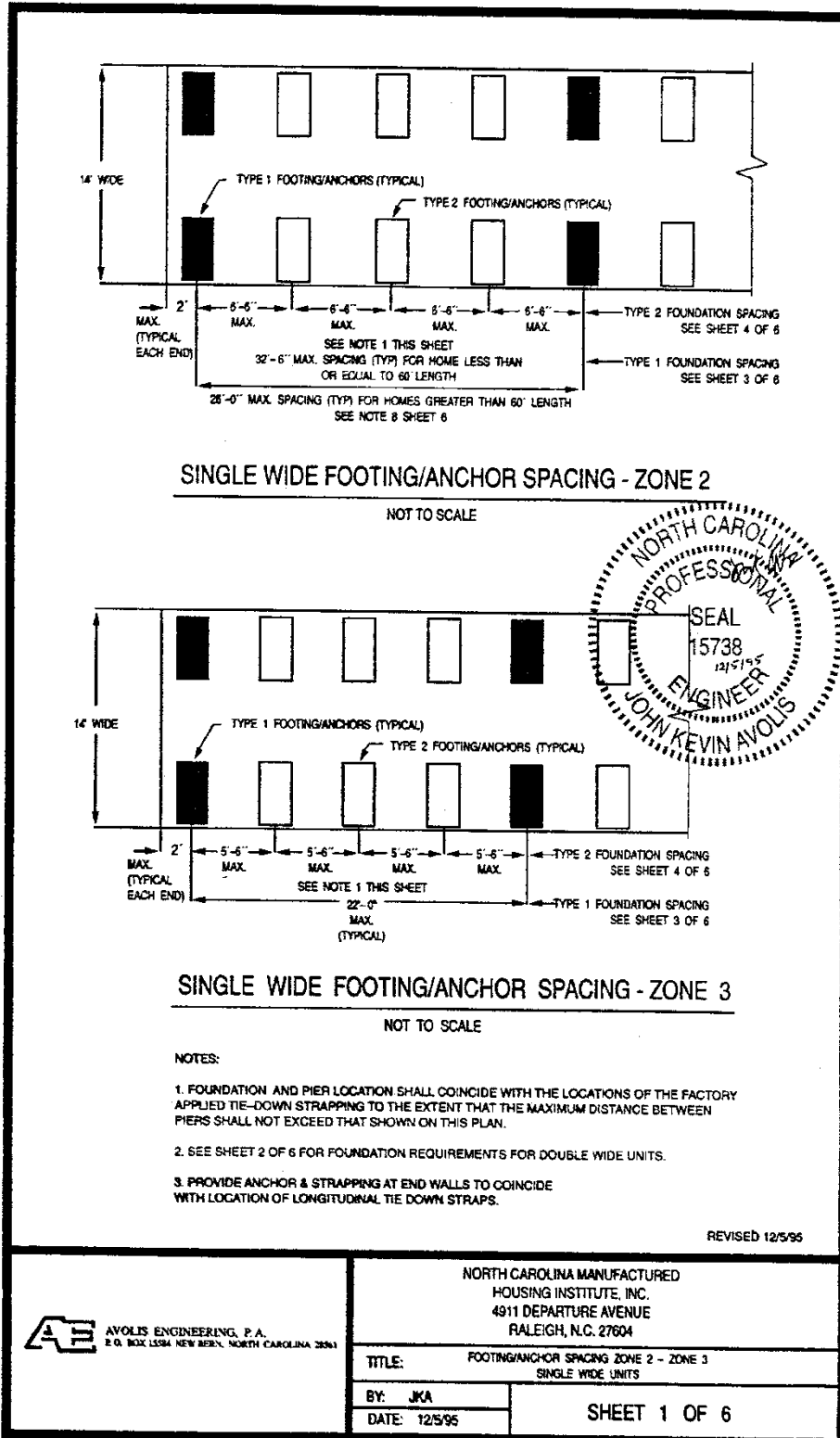

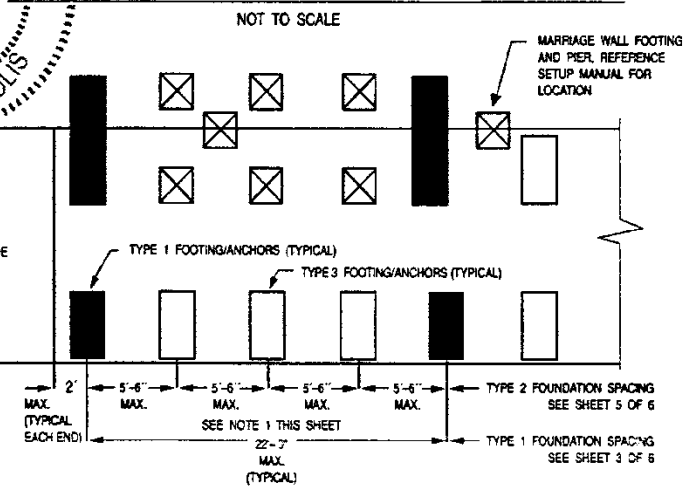
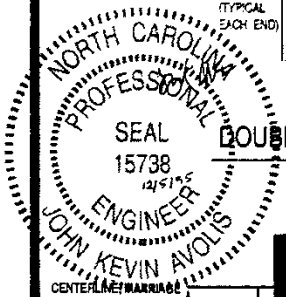
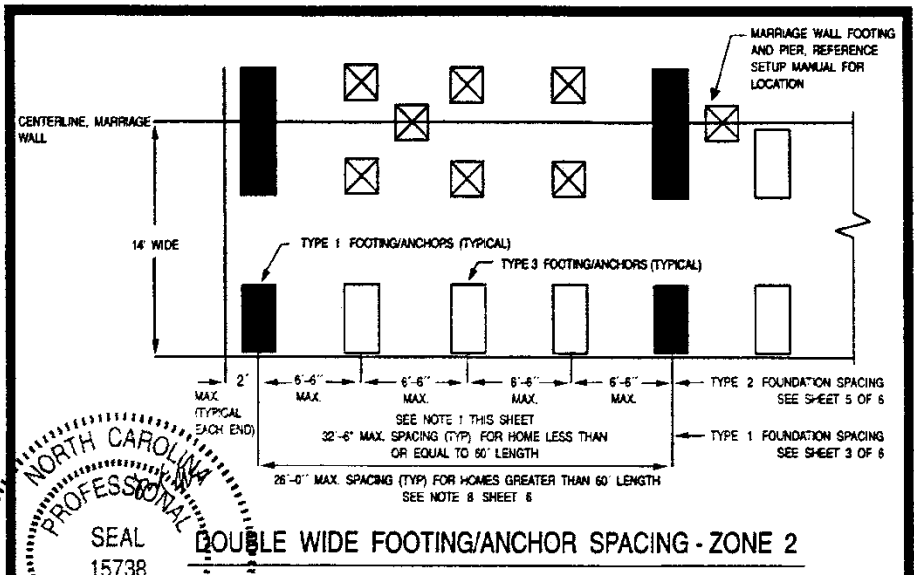

NOTES:

1. FOUNDATION AND PIER LOCATION SHALL COINCIDE WITH THE LOCATIONS OF THE FACTORY APPLIED TIE-DOWN STRAPPING TO THE EXTENT THAT THE MAXIMUM DISTANCE BETWEEN PIERS SHALL NOT EXCEED THAT SHOWN ON THIS PLAN.
2. PLAN IS SYMMETRICAL ABOUT THE CENTERLINE FOR DOUBLE WIDE UNITS.
3. PROVIDE ANCHOR & STRAPPING AT END WALLS TO COINCIDE WITH LOCATION OF LONGITUDINAL TIE DOWN STRAPS.

REVISED 12/5/95

| | | |
|--|--|---------------------|
| AVOLIS ENGINEERING, P.A. P.O. BOX 15584 NEW BERN, NORTH CAROLINA 28541 | NORTH CAROLINA MANUFACTURED HOUSING INSTITUTE, INC. 4911 DEPARTURE AVENUE RALEIGH, N. C. 27604 | |
| | TITLE: FOOTING/ANCHOR SPACING ZONE 2 - ZONE 3 DOUBLE WIDE UNITS | |
| | BY: JKA DATE: 12/5/95 | SHEET 2 OF 6 |

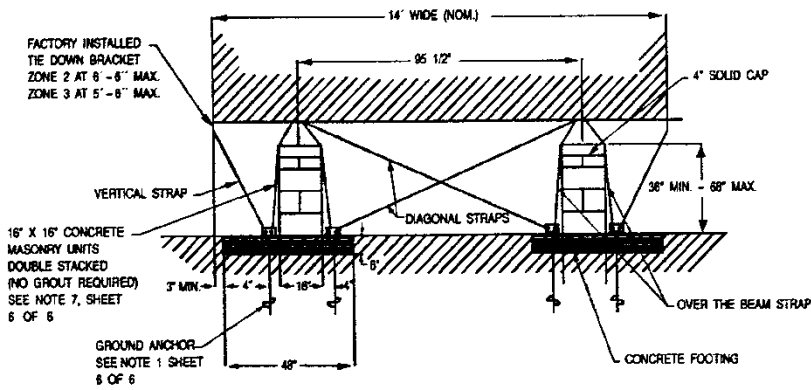

TYPE 1 FOUNDATION - ELEVATION

NOT TO SCALE

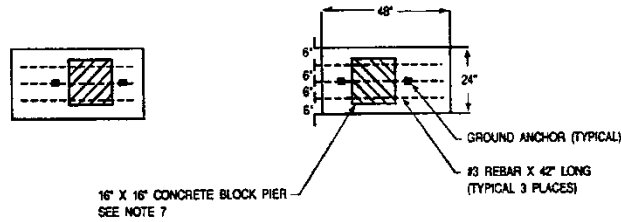

TYPE 1 FOUNDATION - PLAN

NOT TO SCALE

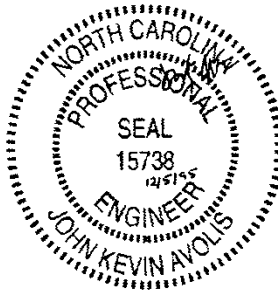

REVISED 12/5/95

AE AVOLIS ENGINEERING, P.A.
P.O. BOX 1584 NEW BERN, NORTH CAROLINA 28511

NORTH CAROLINA MANUFACTURED
HOUSING INSTITUTE, INC.
4911 DEPARTURE AVENUE
RALEIGH, N.C. 27604

TITLE: FLOOD HAZARD AREA FOUNDATION
TYPE 1 FOUNDATION

BY: JKA
DATE: 12/5/95

SHEET 3 OF 6

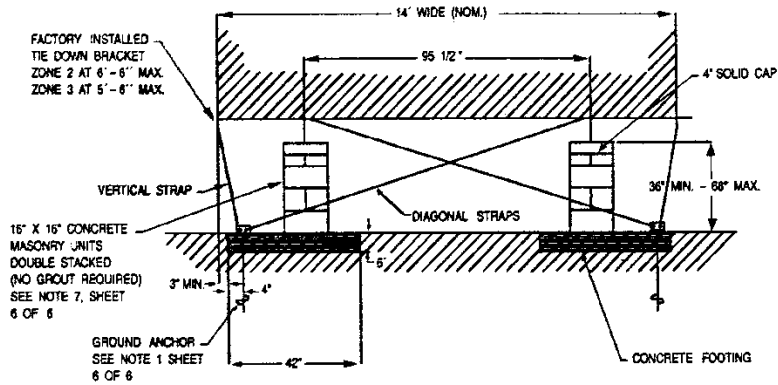

TYPE 2 FOUNDATION - ELEVATION

NOT TO SCALE

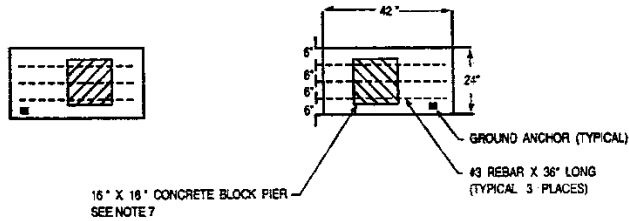

TYPE 2 FOUNDATION - PLAN

NOT TO SCALE

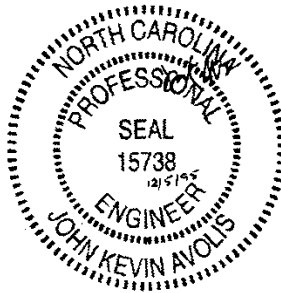

REVISED 12/5/95

AE AVOLIS ENGINEERING, P.A.
P. O. BOX 15384 NEW BERN, NORTH CAROLINA 28541

NORTH CAROLINA MANUFACTURED
HOUSING INSTITUTE, INC.
4911 DEPARTURE AVENUE
RALEIGH, N. C. 27604

TITLE: FLOOD HAZARD AREA FOUNDATION
TYPE 2 FOUNDATION - SINGLE WIDE UNITS

BY: JKA
DATE: 12/5/95

SHEET 4 OF 6

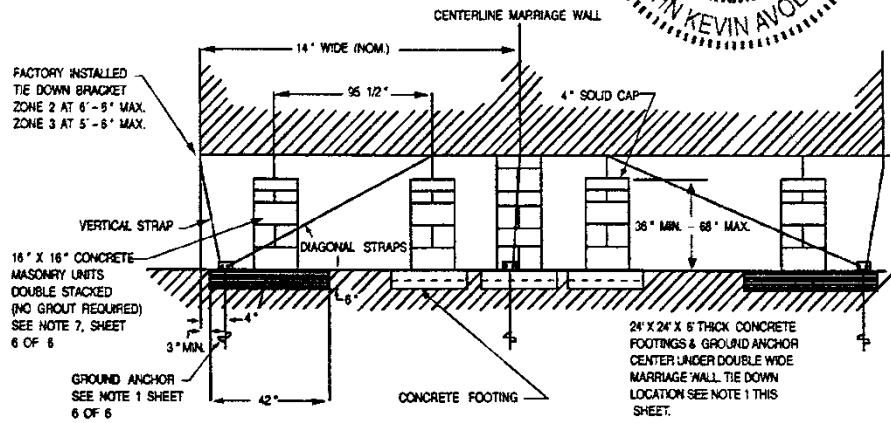
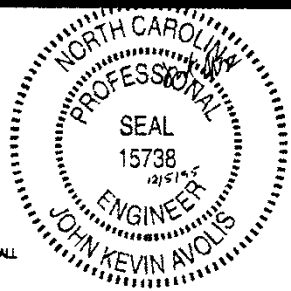

TYPE 3 FOUNDATION - ELEVATION

NOT TO SCALE

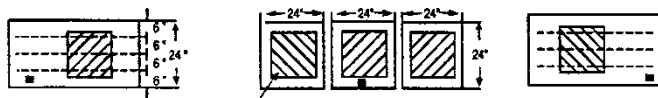

16" X 16" CONCRETE BLOCK PIER
SEE NOTE 7, SHEET 6 OF 6

■ STRAPS ARE NOT SHOWN
FOR CLARITY

TYPE 3 FOUNDATION - PLAN

NOT TO SCALE

NOTES:

1. IF THE MARRIAGE WALL TIE LOCATION COINCIDES WITH THE TYPE 1 FOUNDATION LOCATION (TYPICALLY THE SITUATION AT THE ENDS OF THE MANUFACTURED HOME), THEN THE MARRIAGE WALL FOOTING SHALL BE PLACED INTEGRAL WITH THE TYPE 1 FOUNDATION ON EACH SIDE OF THE DOUBLE WIDE.

REVISED 12/5/95

AE AVOLIS ENGINEERING, P.A.
P. O. BOX 15584 NEW BERN, NORTH CAROLINA 28561

NORTH CAROLINA MANUFACTURED
HOUSING INSTITUTE, INC.
4911 DEPARTURE AVENUE
RALEIGH, N.C. 27604

TITLE: FLOOD HAZARD AREA FOUNDATION
TYPE 3 FOUNDATION - DOUBLE WIDE UNITS

BY: JKA
DATE: 12/5/95

SHEET 5 OF 6

APPLICATION OF DESIGN:

THIS DESIGN WAS FORMULATED UTILIZING THE DESIGN CRITERIA SPECIFIED BELOW. IT SHALL BE THE RESPONSIBILITY OF ALL PERSONS UTILIZING THIS DESIGN TO ENSURE THAT ALL OF THE DESIGN CRITERIA ARE APPLICABLE FOR THE SITE ON WHICH THE MANUFACTURED HOME WILL BE INSTALLED. NON-FLOOD HAZARD AREAS AND/OR AREAS WITH A LOWER DESIGN WIND VELOCITY AS PRESCRIBED BY THE NORTH CAROLINA STATE BUILDING CODE, VOLUME I MAY UTILIZE THIS DESIGN TO INSTALL MANUFACTURED HOMES TO THE MAXIMUM HEIGHT SPECIFIED; HOWEVER, OTHER SPECIAL SITE CONDITIONS MAY EXIST ON THESE SITES WHICH WERE NOT CONSIDERED IN THIS DESIGN. THE USERS OF THIS DESIGN ARE RESPONSIBLE FOR ENSURING THAT ALL SUCH SITE SPECIFIC CONDITIONS ARE PROPERLY ADDRESSED.

DESIGN CRITERIA:

MAXIMUM WIND VELOCITY: ZONE 2: 100 MPH
 ZONE 3: 110 MPH

ROOF LIVE LOAD..... 20 PSF
 FLOOR LIVE LOAD..... 40 PSF
 FLOOR DEAD LOAD..... 20 PSF
 MAXIMUM FLOOD VELOCITY..... 5 FPS
 MINIMUM SOIL BEARING CAPACITY... 2000 PSF
 MAXIMUM EAVE WIDTH..... 12 INCHES

NOTES:

1. ALL GROUND ANCHORS SHALL DEVELOP A MINIMUM TOTAL WITHDRAWAL RESISTANCE OF 3150 POUNDS IN THE TYPE SOIL IN WHICH THEY WILL BE INSTALLED. THE INSTALLER SHALL VERIFY THAT THE ANCHORING SYSTEM PROPOSED MEETS OR EXCEEDS THE 3150 POUND CAPACITY IN THE SOIL TYPE IN WHICH IT IS BEING INSTALLED.
2. GALVANIZED STRAPPING SHALL BE 1/4" WIDE MIN. X 0.035" THICK MIN. HOT DIPPED GALVANIZED, MEETING THE REQUIREMENTS OF FEDERAL SPECIFICATION QQ-S-781H FOR TYPE I, CLASS B, GRADE 1 STRAPPING. THE STRAPPING SHALL HAVE A MINIMUM TENSILE STRENGTH OF 4725 POUNDS.
3. SCREW ANCHOR CLAMPS, TENSIONING ADJUSTERS, AND OTHER ANCHOR HARDWARE SHALL NOT LIMIT THE OVERALL CAPACITY OF THE ANCHORING SYSTEM BELOW 4725 POUNDS PER ANCHOR.
4. FOUNDATION SKIRTING SHALL BE DESIGNED TO BREAKAWAY AT A MAXIMUM LATERAL FORCE OF 15 PSF. NO PERMANENT FOUNDATION SKIRTING IS ALLOWED UNDER THIS DESIGN.
5. ALL CONCRETE SHALL HAVE A MINIMUM COMPRESSIVE STRENGTH OF 2500 psi @ 28 DAYS.
6. ALL REINFORCING STEEL SHALL BE MINIMUM GRADE 40.
7. FOR HOMES SET UP OVER 48 INCHES FROM NATURAL GRADE TO THE BOTTOM OF THE CHASSIS ON THE OUTER BANKS IN EXPOSURE "D" OR WITHIN 500 FEET OF ANY BODY OF WATER THAT IS INFLUENCED BY FLOODING OR IS SUBJECT TO WAVE ACTION, ALL MASONRY PIERS SHALL BE CONSTRUCTED OF 75% SOLID CONCRETE MASONRY UNITS AND SHALL UTILIZE MINIMUM 48-INCH ANCHORS ACHIEVING THE MINIMUM CAPACITIES SPECIFIED IN ITEM 1 ABOVE.
8. ALL HOMES 60 FEET IN LENGTH OR LESS SHALL HAVE A MINIMUM OF THREE (3) TYPE 1 FOUNDATIONS ON EACH SUPPORT RAIL SPACED NOT MORE THAN 32'- 6" ON CENTERS. ALL HOMES GREATER THAN 60 FEET IN LENGTH SHALL HAVE A MINIMUM OF FOUR (4) TYPE 1 FOUNDATIONS ON EACH SUPPORT RAIL PLACED AT NOT MORE THAN 26'- 0" ON CENTERS.

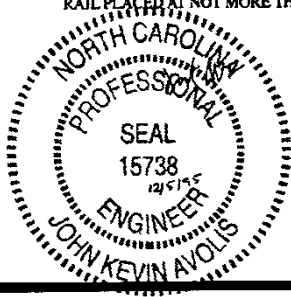

REVISED 12/5/95

AE AVOLIS ENGINEERING, P.A.
 P.O. BOX 1554 NEW BERN, NORTH CAROLINA 28541

NORTH CAROLINA MANUFACTURED
 HOUSING INSTITUTE, INC.
 4911 DEPARTURE AVENUE
 RALEIGH, N. C. 27604

| | |
|---------------|--------------|
| TITLE: | NOTES |
| BY: JKA | SHEET 6 OF 6 |
| DATE: 12/5/95 | |

APPENDIX B

CONVERSION OF MANUFACTURED HOME TO AN OCCUPANCY OTHER THAN SINGLE FAMILY DWELLING

Manufactured homes are constructed in compliance with Federal Standards, specifically **Part 3280, *Manufactured Home Construction and Safety Standards***. Section § 3280.1 of this document indicates that manufactured homes are to be used exclusively as *dwelling units*. The Manufactured Building Division frequently receives inquiries concerning the use of a manufactured home as a sales office, beauty salon, or other type of commercial occupancy for which the home was clearly not designed. All commercial buildings in North Carolina are required to conform to the requirements of applicable volumes of the North Carolina State Building Code (current editions) -- ***NC Building Code, NC Plumbing Code, NC Mechanical Code, NC Electrical Code, NC Fuel Gas Code*** (if applicable), **and the *NC Energy Conservation Code***. One and two family dwellings and townhouses must comply with current editions of the ***NC Residential Code, NC Plumbing Code, NC Mechanical Code, NC Electrical Code, and NC Fuel Gas Code***, (if applicable). Since manufactured homes are constructed to Federal Standards rather than the North Carolina State Building Code, use of these homes *without modification* for other than dwelling units is prohibited.

The above restriction notwithstanding, if a manufactured home owner wishes to upgrade his or her home such that it meets the provisions of all applicable volumes of the ***North Carolina State Building Code***, this modification will be permitted. The upgraded unit, no longer considered a manufactured home, will be acceptable for the commercial occupancy to which it has been modified. The following steps must be followed in carrying out the upgrade:

1. A professional engineer or architect, currently registered in North Carolina, must be retained to inspect the unit for evaluation of the existing structural, plumbing, mechanical, and electrical systems. This evaluation will determine whether these systems meet *all* applicable standards in the ***North Carolina State Building Code*** for the intended occupancy. If any part of a system is not compliant, the engineer or architect must determine what corrective measures will be required to bring the unit into compliance with current Code standards. This procedure will normally require portions of the walls, ceilings, and/or floors to be removed in order to facilitate an adequate inspection. From this inspection and evaluation the engineer or architect must produce a summary list indicating which items meet current Code requirements and which items must be modified for Code compliance.
2. All items that are not in compliance with current applicable Code volumes must be modified in accordance with the engineer or architect's specific instructions. All such corrective work must be inspected by the engineer or architect (or their authorized representative) prior to being covered with finished wall, ceiling, or floor material.
3. The engineer or architect must also evaluate the foundation system for the unit to determine if it meets North Carolina State Building Code requirements for the intended occupancy. If the foundation is inadequate, necessary modifications must be specified and inspected after completion by the engineer or architect (or their authorized representative).
4. All accessibility requirements for the intended occupancy must be provided in accordance with the ***Chapter 11, NC Building Code***, current edition
5. When all required modifications to the building, including the foundation, have been completed, the engineer or architect must provide *sealed documentation* to the local building official certifying the he or she (or their authorized representative) has *personally inspected* all the work and has determined that the building now meets all current requirements of the ***North Carolina State Building Code*** for the intended occupancy.

When the above steps are properly completed, a local building official shall accept the upgraded manufactured home for use as a commercial occupancy.

APPENDIX C

REPAIR OF DAMAGED HOMES, REFURBISHED HOMES, AND HOMES SOLD FOR SALVAGE

In the aftermath of Hurricane Floyd, the Manufactured Building Division, acting in its capacity as staff to the North Carolina Manufactured Housing Board and as the State Administrative Agency (SAA) for HUD, issued documentation intended to provide guidance to manufactured home consumers, manufacturers, dealers, contractors, and local inspectors regarding the procedures for the repair of homes damaged during the storm. This documentation was published in the form of frequently asked and anticipated questions from interested parties. This **Appendix** summarizes the information from this documentation, and is divided into **Sections C.1, C.2 and C.3**, which will deal primarily with manufacturers and dealers (**C.1**), consumers (**C.2**), and refurbished homes (**C.3**).

*Although originally dealing with primarily flood damaged homes, **the same principles will apply to homes damaged by fire, transportation, or other causes, as well as homes “sold for salvage”.** For the purposes of this **Appendix**, a home “sold for salvage” is one that has had the HUD label removed and is sold on an “as is” basis with full disclosure of its condition and lack of label to the consumer.*

C.1 NEW/USED HOMES – LOCATED ON A DEALER’S LOT – NOT SOLD TO A CONSUMER

C1.1 NEW Homes Shall Be Brought Back Into Compliance Prior to Sale.

Damaged **NEW** homes located on a dealer’s lot that have not been sold are currently out of compliance with the **Federal (HUD) Standards (24 CFR Part 3280, Manufactured Home Construction and Safety Standards)** because of substantial damage due to flooding, fire, transportation, etc. These units are prohibited from being sold/leased or being offered for sale/lease until they are brought back into compliance with HUD standards.

Each damaged unit shall be visually inspected to determine the potential non-compliance, and the home shall be repaired and brought back into compliance under the Federal Standards prior to sale.

The dealership shall fully coordinate its efforts with the manufacturer to assure that the homes are brought back into compliance with the Federal Standards, and that applicable warranties are not voided.

C1.2 Determination as to Whether the Home Can Be Repaired so as to Comply with the Federal Standards.

Because these homes have incurred substantial damage, the dealer must involve the manufacturer in evaluating **each** damaged unit to determine:

- (1) if the unit can be repaired,
- (2) what repair methods are to be used to bring the home back into compliance with the Federal Standards, and
- (3) who is authorized to make the repairs.

A qualified representative *from the manufacturer* shall determine by physical inspection if the unit can be repaired. This person must have *extensive knowledge* of all aspects of manufactured home construction.

Once the manufacturer has determined the extent of the damage, then the method of repair that will be used to bring the home back into compliance with the Federal Standards must be determined. *These methods of repair shall be drawn up and approved by the manufacturer’s Design Approval Primary Inspection Agency (DAPIA).*

If it is determined that a home is damaged *beyond repair*, then the manufacturer must notify their *Production Inspection Primary Inspection Agency (IPIA)* and their *State Administrative Agency (SAA)*. The IPIA shall remove the HUD labels from the home, return them to HUD, and shall clearly mark the Data Plate as “VOID”.

As an alternate, the damaged home may be “sold for salvage”. A home that is “sold for salvage” is one that has had the *HUD label removed* and is sold on an “as is” basis *with full disclosure of its condition and lack of label to the consumer*. HUD labels for such homes *shall be removed by the dealer and sent to the NC Department of Insurance, Manufactured Building Division*. The Data Plates shall be clearly marked as “VOID”.

C1.3 Party Authorized to Make Repairs to the Manufactured Home.

The manufacturer is the only party who can determine the proper repair method for the defect.

The manufacturer is *solely* responsible for the scope of the repairs.

A dealer may make the repairs if, at the manufacturer's option, the manufacturer believes that the methods of correction are within the expertise and abilities of the dealer.

C1.4 Where Repairs Can Be Made

The repairs can be made at the manufacturer's plant facility or any other place that the manufacturer finds to be acceptable.

C1.5 Responsibility for Inspection of Repairs

Since these homes have incurred substantial damage, the dealer/manufacturer must *request verification of the repairs from the manufacturer's IPIA*. *The manufacturer's in-plant inspection agency (IPIA) is responsible* for verifying that the repairs have been properly made using the manufacturer's approved repair methods and for certifying that the unit has been brought back into compliance with the Federal Standards.

C1.6 Removal of HUD Labels from Homes which Cannot Be Repaired

In some cases the manufacturer may determine that the home cannot be repaired, and will be subsequently demolished. For all homes which cannot be brought back into compliance with the Federal Standards, *it is the responsibility of the manufacturer's IPIA* to remove the HUD labels from the home, return them to HUD, and clearly mark the Data Plate as "VOID".

C1.7 Responsibility for Damaged NEW Homes Sold to Consumers but Not Yet Delivered

The dealer and the manufacturer are responsible for damaged homes sold but not yet delivered using the same procedures as indicated in **Sections C1.1 through C1.5** for homes that have not been sold.

Under the Federal Regulations (§ **3282.252**) the dealer and manufacturer are responsible for all these damaged homes *"until the completion of the entire sales transaction."*

The Federal Regulations (§ **3282.252(b)**) state that *"A sales transaction with a purchaser is considered complete when all the goods and services that the dealer agreed to provide at the time of the contract was entered into have been provided."*

The following is an example of HUD's interpretation of this section:

A dealer has included skirting in his contract with the consumer. The home has been delivered to the site, set-up, and the consumer has moved in but the skirting was not installed before the storm struck. Under the Federal Regulations the sales transaction in question has not been completed because the skirting has not been installed and therefore the dealer is responsible for the storm damage as if the unit was still on his lot.

The repair guidelines for this home would be the same as indicated above for homes that have not been sold.

C1.8 Repair of USED Homes on Dealer's Lot that have Not Been Sold

Manufactured homes are constructed to meet the requirements of *Part 3280, Manufactured Home Construction and Safety Standards*. Repairs to a **USED** manufactured home which utilize **materials and construction methods which are equal to or better than those used when the home was originally constructed** shall be accepted.

As an alternate, the damaged home may be "sold for salvage". A home that is "sold for salvage" is one that has had the *HUD label removed* and is sold on an "as is" basis *with full disclosure of its condition and lack of label to the consumer*. HUD labels for such homes *shall be removed by the dealer and sent to the NC Department of Insurance, Manufactured Building Division*. The Data Plates shall be clearly marked as "VOID".

C1.9 Trade In of a Damaged Home

A consumer may wish to trade in a damaged manufactured home. The home may be taken by a dealer on trade, repaired, and then resold subject to the following:

Manufactured homes are constructed to meet the requirements of *Part 3280, Manufactured Home Construction and Safety Standards*. We will accept repairs to a **USED** manufactured home which utilize **materials and construction methods which are equal to or better than those used when the home was originally constructed**.

C1.10 Information and Records Required for each Damaged

The NC Department of Insurance, Manufactured Building Division requires the following on NEW homes: (*Submittal of this information in a Microsoft Excel, Access or Word document is preferable if these are available*)

From Dealers the following is required:

1. A comprehensive list of all damaged homes by manufacturer and serial number
2. Detailed description of damage of each home indicating:
 - a. Type of damage: wind, flooding, fire, transportation, etc.
 - b. Location of damage area: **F**ront, **B**ack, **F**loor, **E**xterior Walls, **I**nterior Walls, **C**eiling, **R**oof (use letter codes)
 - c. Corrective Action
 - d. Expected time frame for repairs
 - e. Notification of repair dates prior to reconstruction.

From the Manufacturers the following is required:

1. Detailed inspection report indicating which affected homes will be repaired and which homes will be destroyed.
2. DAPIA approved methods of repair for all affected areas.
3. Notification that Manufacturer's repair personnel will be making repairs or notification of manufacturer's approved dealers who will be making the repairs.
4. Proposed schedule of repairs
5. Notification that the manufacturer's IPIA will be performing on-site inspections of repairs for each affected home.

From the IPIA a full report is required indicating the following:

1. Name of IPIA
2. Name of IPIA inspector
3. Schedule indicating Date and time of inspection(s)
4. Name and Location of Dealer's Lot
5. Name of Manufacturer of unit to be repaired
6. Serial number of unit to be repaired.
7. Nature of nonconformance in detail for each unit
8. Corrective Action in Detail
9. Final Inspection Date
10. Final Recertification Date
11. List of HUD labels removed from destroyed homes

C.2 DAMAGED HOMES OWNED BY CONSUMER -- LOCATED ON CONSUMER'S LOT OR RENTAL LOT

C.2.1 Repair of Damaged or Sold for Salvage Homes Located on Consumer's Lot

The consumer's decision as to whether to have repairs made will depend on many factors such as the extent of the damage and the cost of getting the home repaired and inspected.

The *State of North Carolina Regulations for Manufactured Homes (Section 1.3.4)* requires that all repairs made to manufactured homes be inspected by either an independent third party inspection agency approved by HUD, an NC Professional Engineer, an NC registered Architect, or by your local building inspector.

When the repairs have been completed, an inspection certification must be submitted to the local jurisdiction (unless they performed the inspections) indicating that the repairs have been properly made before a Certificate of Occupancy can be issued.

C.2.2 Determination of Whether Home Can Be Repaired

It is recommended that the local building official be contacted first. The local official can quickly determine if the home is safe to enter. If unsafe, the inspector will have power disconnected from the home and will notify the consumer of specific safety concerns.

The local inspector will also be able to provide information as to whether the local department is willing to take responsibility for inspecting any repairs that are made to the home.

Manufactured homes are built under a Federal inspection program which is not under the jurisdiction of local inspectors. Because of this, the local inspector may decide that it will be necessary to contract with either a third party inspection agency approved by HUD, an NC Professional Engineer, or an NC registered Architect for getting the repairs to the home inspected. When the repairs are complete, an inspection certification must be submitted by the third party agency, engineer, or architect to the local jurisdiction indicating that the repairs have been properly made before a Certificate of Occupancy can be issued.

C2.3 Building Code and Construction Standard to which Repairs Must Comply

Manufactured homes are constructed to meet the requirements of *Part 3280, Manufactured Home Construction and Safety Standards*. This Federal Standard is not readily available to local jurisdictions in North Carolina. Most local engineers, architects and inspectors in North Carolina have little if any experience working with this Federal Standard. **Section 1.3.4** of the *State of North Carolina Regulations for Manufactured Homes* allows repairs to be made in accordance with the North Carolina Residential Code. It is recognized that it would be impractical in many cases to repair a significantly damaged manufactured home to meet the requirements of the North Carolina Residential Code. For this reason, repairs to a **USED** manufactured home which utilize **materials and construction methods which are equal to or better than those used** when the home was originally constructed shall be accepted.

C2.4 Where Repairs Can Be Made

Repairs may be made at any location found to be suitable to the individual or agency that is going to conduct the inspection of the repairs.

C2.5 Purchase of a Damaged NEW Home from a Dealer

A consumer may purchase a damaged NEW home from a dealer. However, the dealer must bring the home back into compliance with *Part 3280, Manufactured Home Construction and Standards* **before it can be sold**, in accordance with the provisions of **Section C.1** above.

C2.6 Inspection of Repairs by Other Than Local Jurisdiction

In some cases, the local jurisdiction may decide not to inspect the repairs to a home, and will instruct the consumer to contract with a third party inspection agency, an NC Professional Engineer, or an NC registered architect to conduct the inspections. Information regarding these alternate means of inspection is as follows:

A list of approved third party inspection agencies can be obtained from HUD at (202) 708-6423 or (800) 927-2891, at the following link to the HUD website:

https://portal.hud.gov/hudportal/HUD?src=/program_offices/housing/rmra/mhs/mhsid

or from the Manufactured Building Division of the NC Department of Insurance at 919-647-0000.

North Carolina Professional Engineers in a particular area may be located by contacting the NC Board of Examiners for Engineers and Surveyors (919-841-4000). North Carolina Registered Architects may be located by contacting the NC Board of Architecture (919-733-9544).

C2.7 Items to Consider in Inspecting Damaged Homes

The following list was prepared specifically for flood damaged homes, but should provide useful guidelines for assessing significant damage from any cause. It is highly recommended that someone *with extensive knowledge of manufactured home construction and set-up requirements* be used to inspect the extent of damage. At a very minimum the following is recommended:

General:

Wear protective clothing.

Electrical:

Make sure electrical service is disconnected if the flood water marks are above electrical devices, services, etc.

Building:

Locate water marks on the home to make an initial determination of the extent of damage.

Look for the following:

- Major structural problems
- Undercut footings
- Leaning, fallen or missing pier supports
- Broken, undercut, loose or missing ground anchors
- Broken, loose or missing anchor straps
- Home moved off foundation
- Home twisted or racked
- Buckled floor/roof/wall sheathing
- Check for damaged finishes
- Ceiling/floor/wall covering
- Roofing/siding have some damaged finishes removed.
- Check for wet ductwork, insulation, wiring/electrical devices

C2.8 Safety of Electrical Systems in Flood Damaged Homes

Some homes are subject to significant depths of water within the home during floods. The question as to whether the electrical system will be safe after drying out is important. With regard to this question, the following is recommended:

Guidelines for Handling Water Damaged Electrical Equipment

A publication that provides guidelines on how to handle electrical equipment that has been exposed to flooding is available from the National Electrical Manufacturers Association (NEMA). This publication may be found at:

<http://www.nema.org/engineering/papers/waterdam.html>

Due to the highly polluted nature of the recent floodwaters, extra care should be used in determining if re-energizing the electrical system is safe. Some things to consider are:

NM Cables - When Type NM cable has been submerged in water, especially if the ends of the cable have been submerged, it should be replaced.

Wiring Devices - Sediments and contaminants contained in floodwaters are difficult to remove from the internal parts even if washed with clean water or solution and dried. Such submerged devices should be replaced.

Circuit Breakers and Panelboards - It may be possible to recondition some of this type of equipment when done by trained personnel in consultation with the manufacturer. This equipment should not be energized until it has been reconditioned or replaced

C.3 REFURBISHED HOMES

C3.1 Approval and Certification of Refurbished Homes

The *State of North Carolina Regulations for Manufactured Homes* (Section 1.3.4) requires that all repairs made to manufactured homes be inspected by either an independent third party inspection agency approved by HUD, an NC Professional Engineer, an NC registered Architect, or by your local building inspector.

When the repairs have been completed, an inspection certification must be submitted to the local jurisdiction (unless they performed the inspections) indicating that the repairs have been properly made before a Certificate of Occupancy can be issued.

Section C.2 above shall be used as a general guideline for the refurbishing process and for the approval of refurbished homes.

APPENDIX D

The purpose of this memorandum is to clarify the position of the NC Department of Insurance on the requirements for the labeling and setting up of “Recreational Park Trailers” (formerly “Park Model” recreational vehicles) as permanent dwelling units. All references herein to the **North Carolina Electrical Code** are to the **2017 Edition** (National Electrical Code (NEC) w/NC Revisions).

RECREATIONAL VEHICLE: (defined by HUD in 24 CFR 3282.8 (g) Manufactured Home Procedural and Enforcement Regulations)

As defined by HUD in 24 CFR 3282.8 (g) Manufactured Home Procedural and Enforcement Regulations

A recreational vehicle is a vehicle which is:

- (1) Built on a single chassis;*
- (2) 400 Square feet or less when measured at the largest horizontal projections;*
- (3) Self-propelled or permanently towable by a light duty truck; and*
- (4) Designed primarily not for use as a permanent dwelling but as temporary living quarters for recreational, camping, travel, or seasonal use.*

As defined in Article 551, NEC

A vehicular-type unit primarily designed as temporary living quarters for recreational, camping, or travel use, which either has its own motive power or is mounted on or drawn by another vehicle. The basic entities are travel trailer, camping trailer, truck camper, and motor home.

As defined in ANSI A119.5, Park Model Recreational Vehicle Standard, 2015 Edition

A vehicular type unit primarily designed as temporary living quarters for recreational, camping, travel or seasonal use, that either has its own motive power, or is mounted on, or towed by another vehicle. The basic entities are: camping trailer, fifth wheel trailer, motor home, travel trailer and truck camper.

PARK MODEL RECREATIONAL VEHICLE - also known as Recreational Park Trailer and Park Model

As defined in ANSI A119.5, Park Model Recreational Vehicle Standard, 2015 Edition

A single living unit that is primarily designed and completed on a single chassis, mounted on wheels, to provide temporary living quarters for recreational, camping, or seasonal use, is certified by the manufacturer as complying with all applicable requirements of ANSI A119.5 and:

- (a) Has a gross trailer area not exceeding 400 square feet (37.15 square meters) in the setup mode or*
- (b) If having a gross trailer area not exceeding 320 square feet (29.72 square meters) in the setup mode, has a width greater than 8.5 ft. (2.59 meters) in the transport mode.*

As defined by Article 552.2, NEC

A unit that is built on a single chassis mounted on wheels and has a gross trailer area not exceeding 37 m² (400 ft²) in the set-up mode.

General Requirements per Article 552.4, NEC

A park trailer as specified in 552.2 is intended for seasonal use. It is not intended as a permanent dwelling unit or for commercial uses such as banks, clinics, offices, or similar.

GROSS TRAILER AREA – (as defined in ANSI A119.5, 2015 Edition)

The total plan area measured to the maximum horizontal projections of exterior walls in the setup mode.

NCDOI Note: Loft areas that are habitable room(s) (5 ft. or greater ceiling height) shall be included in the gross trailer areas. Accessible loft spaces with ceiling height less than 5 ft. are not included in the gross trailer area. Per HUD, roof overhangs are not included in the calculation of the gross trailer area. Any units to be labeled under the HUD manufactured housing program must contain a minimum of 320 sq. ft. in gross trailer area.

NORTH CAROLINA CODE REQUIREMENTS:

Recreational Park Trailer - Electrical Supply System

The **electrical supply system** to Recreational Park Trailers is required to be installed and inspected in accordance with the **2017 North Carolina Electrical Code (NEC with NC Amendments)**. See **interpretations for Articles 551 and 552 from the NC State Electrical Division. (919-647-0000)**

Recreational Park Trailer - Temporary Installation

Since these units are defined to be temporary structures, it is not permissible to set them up as permanent dwelling units. Therefore, it is our interpretation that they cannot have any permanent electrical, plumbing or mechanical connections. However, for safety reasons we will allow these units to be temporarily blocked up and anchored against overturning forces, but to remain classified as a temporary structure, the wheels and axles must remain on the unit at all times. We recommend that all recreational vehicles used for temporary recreational dwellings be set-up in accordance with the manufacturer's recommendations. Accessory structures may not be supported by these units.

Recreational Park Trailers – Permanent Installation

A Recreational Park Trailers constructed in accordance with **ANSI A119.5, Recreational Park Trailer Standard** and only labeled as a Recreational Park Trailer under the Recreational Park Trailer construction program of **the Recreational Vehicle Industry Association (RVIA)**, **cannot be** accepted as a permanent dwelling structure in North Carolina. **However**, sometimes manufacturers will dual label their Recreational Park Trailers by constructing them through the RVIA program and also through the NC Modular Construction Program or the HUD Manufactured Housing program, dual labeling the unit for each respective program. Labeled Recreational Park Trailers that are also constructed and dual labeled in accordance with the **NC Modular Construction Program** may be permanently installed as a single family modular dwelling in accordance with the **NC Residential Code** provided the installation meets the current NC Code’s foundation/anchoring requirements and meets the local zoning ordinances. This is acceptable because the unit is dual labeled with a North Carolina Modular Construction Validating Stamp as a modular dwelling unit. Labeled Recreational Park Trailers that are also constructed and dual labeled in accordance with the **Federal Manufactured Housing Construction and Safety Standards** as a single family (HUD) manufactured home may be permanently installed as a single family manufactured home dwelling in accordance with the **State of North Carolina Regulations for Manufactured Homes** provided the installation meets the foundation/anchoring requirements of these regulations and the local zoning ordinances. This is acceptable because the unit is dual labeled with a HUD manufactured housing label.

Recreational Park Trailers - Unlabeled/Site Constructed

Some manufacturers are not members of the **Recreational Vehicle Industry Association (RVIA)** and are not authorized/able to certify and label their Recreational Park Trailers as being constructed in accordance with the **ANSI A119.5, Recreational Park Trailer Standard** under the RVIA Recreational Park Trailer construction program. Unlabeled and/or site-constructed Recreational Park Trailers **cannot be** accepted as a permanent dwelling structure in North Carolina. Unlabeled and/or site-constructed Recreational Park Trailers must meet the electrical construction and inspection requirements as indicated above and must be no larger than 400 sq.ft. gross trailer area as defined in **ANSI A119.5, Recreational Park Trailer Standard – 2015 Edition**. All unlabeled and/or site constructed recreational park trailers greater than 400 sq.ft. gross trailer area will be considered to be a non-complying single family dwelling in violation of the **NC Residential Code**.

LABELS

Labels – Acceptable Examples of Recreational Park Trailer (Park Model) Labels for Temporary Use

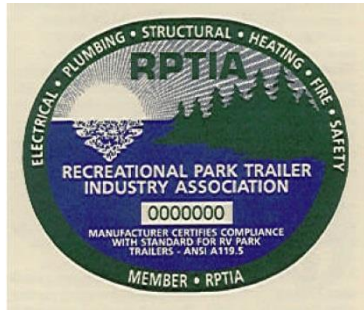

RVIA Park Model Label (oldest units) RPTIA Park Model Label (older units) RVIA Recreational Park Trailer Label (new units)

Labels – Required for Permanent Installations

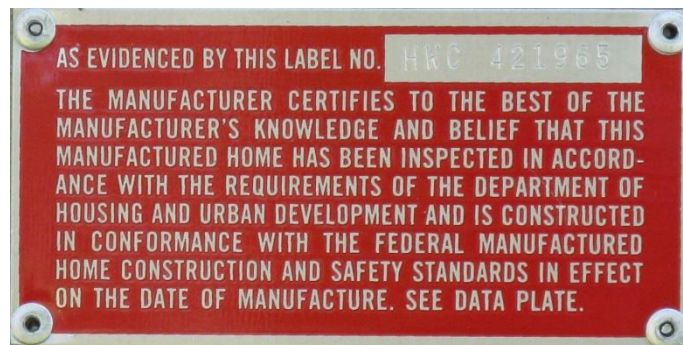
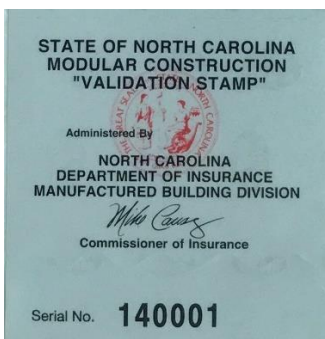

NC Modular Construction Validating Stamp

HUD Manufactured Housing Label

APPENDIX E

SUGGESTED GUIDELINES FOR ACCEPTANCE OF PRE-HUD MANUFACTURED HOMES

Prior to July 1, 1970, the construction of mobile homes was basically unregulated in North Carolina. ANSI A119.1, *Standard for Mobile Homes*, was available but not mandatory. Effective July 1, 1970, a "Label of Compliance" indicating conformance to ANSI 119.1 became mandatory in North Carolina. Federal law passed in 1974 provided for construction of manufactured homes to be in accordance with Federal Standards, which preempted the power of all States over all manufactured home units. The Federal Standards became effective on June 15, 1976, and all homes with a date of manufacture on or after this date were required to have a HUD label indicating compliance with the Standards. This Appendix is intended as guideline for local inspection jurisdictions in accepting manufactured homes with a date of manufacture *prior to June 15, 1976*, and thus having no HUD label. Such homes should comply, at a minimum, with the provisions of this Appendix.

E1 Exits, Exit Doors, and Egress Windows

E1.1 Exits

Each home shall have a minimum of two exterior doors located remote from each other and so arranged as to provide a means of unobstructed travel to the outside of the home.

E1.2 Exit Doors

Exit doors shall be constructed for exterior use and in no case be less than 24 inches wide (22 inches clear). Exterior door hardware shall be arranged to be readily opened from inside of the home. The locking mechanism shall be engaged or disengaged by the use of a lever, knob, button, handle, or other device from the inside of the home. Locks shall not require the use of a key for operation from the inside.

E1.3 Egress Windows

Each bedroom that does not have a door leading directly to the outside shall have at least one egress window which can be opened from the inside without the use of tools. The window shall provide a clear opening of not less than 22 inches in least dimension and not less than 5 square feet in area. The bottom of the opening shall be not more than 4 feet above the floor. Where a screen or storm window is required to be removed from the window to permit emergency egress, it shall be readily removable without requiring the use of tools.

E2 Flame Spread

E2.1 Interior Walls, Partitions, and Ceilings

The interior finish of habitable rooms and hallways (excluding molding, doors, trim, cabinets, and splash panels), enclosures for furnaces and water heaters (including doors) shall be of materials whose flame spread classification shall not exceed 200. A door or doors serving a closet with an opening exceeding 21 square feet shall comply with this requirement.

E3 Vertical Clearance Above Gas Ranges

Gas ranges shall have a vertical clearance above the cooking top of not less than 30 inches to combustible material or metal cabinets except the clearance may be reduced to not less than 24 inches as follows:

The underside of the combustible material or metal cabinet above the cooking top is protected with 5/16" gypsum board or equivalent material covered with sheet metal not lighter than No. 28 manufacturer's standard gage, or

A metal ventilating hood of not lighter than No. 28 manufacturer's standard gage sheet metal is installed above the cooking top with a clearance of not less than 1/4 inch between the hood and the underside of the combustible material or metal cabinet, and the hood is at least as wide as the range and is centered over the range.

E4 Smoke Detectors

E4.1 General

At least one listed smoke detector (which may be a single station alarm device) shall be installed in each manufactured home. Detectors shall operate from an AC, monitored battery, or combination AC/battery power source.

E4.2 Smoke Detector Location

Smoke detector(s) shall be located outside of bedrooms, in a hallway or space communicating thereto, on or near the ceiling, and shall be installed in accordance with the manufacturer's instructions. Homes having bedrooms separated by any one or combination of common use areas, such as a kitchen, dining room, living room, or family room (but not a bathroom or utility room), shall have at least two detectors.

E4.3 Alarm Sounding Device

Every smoke-detecting device shall cause the operation of an alarm signaling device or devices which shall be clearly audible in all bedrooms with all intervening doors closed.

E4.4 Detector Trouble Signals

Detectors requiring a light source for operation shall have an audible trouble signal on failure of the light source, but such failure shall not cause an alarm. Detectors not requiring a light source for operation shall have either a visible light to indicate operability or an audible trouble signal. Audible trouble signals shall be designed to operate at least every minute for seven consecutive days.

E5 Solid Fuel Burning Stoves / Fireplaces

E5.1 Solid Fuel Burning Fireplaces and Fireplace Stoves

Solid fuel burning, factory-built fireplaces and fireplace stoves may be used in manufactured homes, provided they are listed for use in manufactured homes and installed in accordance with their listing.

E5.2 Equipment

A solid fuel burning fireplace or fireplace stove shall be equipped with an integral door or shutters designed to close the fire chamber opening and shall include complete means for venting through the roof, a combustion air inlet, a hearth extension, and means to securely attach the unit to the manufactured home.

E5.3 Chimney

A listed, factory-built chimney designed to be attached directly to the fireplace or fireplace stove and equipped with, in accordance with the listing, a termination device and spark arrester, shall be required. The chimney shall extend at least 3 feet above the part of the roof through which it passes and at least 2 feet above the highest elevation of any part of the manufactured home that is within 10 feet of the chimney.

E5.4 Air Intake Assembly and Combustion Air Inlet

An air intake assembly shall be installed in accordance with its listing and the manufacturer's instructions. A combustion air inlet shall conduct the air directly into the fire chamber and shall be designed such that material from the hearth is prevented from dropping onto the area beneath the manufactured home.

E5.5 Hearth Extension

The hearth extension shall be of noncombustible material that is a minimum of 3/8 inches thick and shall extend a minimum of 16 inches in front and 8 inches beyond each side of the fireplace or fireplace stove opening. The hearth shall also extend over the entire surface beneath a fireplace stove and beneath an elevated or overhanging fireplace.

E6 Electrical System

E6.1 Testing

Electrical testing of the home shall be in accordance with **Section 3.12.6** of this Code.

E6.2 Protection

The electrical system shall be properly protected for the required amperage load. If the unit wiring employs aluminum conductors, all receptacles and switches rated at 20 amperes or less that are directly connected to the aluminum conductors shall be marked CO/ALR. Exterior receptacles, other than heat tape receptacles, shall be of the ground fault circuit interrupter (GFCI) type. Conductors of dissimilar metals (copper/aluminum or copper clad aluminum) must be connected in accordance with **Section 110-14, 2008 NEC**.

E7 Replacement Furnaces and Water Heaters

E7.1 Listing

Replacement furnaces or water heaters shall be listed for use in a manufactured home. Vents, roof jacks, and chimneys necessary for the installation shall be listed for use with the furnace or water heater.

E7.2 Securement and Accessibility

Furnaces and water heaters shall be secured in place to avoid displacement. Every furnace and water heater shall be accessible for servicing, for replacement, or both.

E7.3 Separation – Fuel-Burning Furnaces and Water Heaters

The required separation for fuel-burning furnaces and water heaters may be achieved by either 1) the installation of a direct vent system (sealed combustion system) furnace or water heater or 2) the installation of the furnace and water heater with enclosures that separate the combustion systems of these appliances from the interior atmosphere of the home. There shall be no doors, grills, removable access panels, or other openings into the enclosure from the inside of the manufactured home. All openings for ducts, piping, wiring, etc., shall be sealed.

E7.4 Support for Water Heater

The floor in the area of the water heater shall be free from moisture damage to insure that the floor will support the weight of the appliance.

APPENDIX F

REQUIREMENTS FOR DEALER LOT SET-UPS

NOTE: Manufactured home dealer lots are routinely monitored by Manufactured Building Division field inspectors as part of North Carolina's State Administrative Agency requirements (see Appendix M). Inspection of dealer lots is not under the normal jurisdiction of local inspection departments.

F1 Homes for Display -- Manufacturer's Guidelines Available

When NEW or USED manufactured homes are being DISPLAYED at the dealer lot for a period of time exceeding 30 days from delivery, if required by the manufacturer, the homes are to be temporarily supported/blocked in accordance with the manufacturer's instructions to prevent damage to the home.

F1.1 Homes for Display -- Manufacturer's Guidelines NOT Available

For NEW or USED manufactured homes for DISPLAY where the manufacturer does not include documentation with the delivery of home identifying guidelines for temporary setup, the dealer must comply with the following procedures:

1. Footings (minimum 16" x 16" x 4" solid concrete blocks) shall be placed on firm, level undisturbed soil, compacted fill, or equivalent. Footings may be placed directly on such surface without excavation.
2. Main I-beam support piers shall be within 2 feet from each end of home and shall be spaced a maximum of 8 feet on center for 8" deep I-beams, 10 feet on center for 10" deep I-beams, and 12 feet on center for 12" deep I-beams. Centerline and perimeter support piers shall be placed on both sides of openings greater than 4 feet.

F2 Homes for Storage

When NEW or USED manufactured homes are being STORED at the dealer lot or other locations for a period of time exceeding 30 days from delivery, the homes are to be temporarily supported/blocked when required by the manufacturer and in accordance with the manufacturer's instructions.

F3 Electrical Requirements for Dealer Lot Set-Ups

F3.1 Feeders / Branch Circuits

Feeders / branch circuits to individual units may be by drops or underground laterals in accordance with applicable provisions of the **2008 NEC**. Due to the temporary nature of the set-ups on the dealer lots, the following special provisions are applicable:

1. Feeder assemblies need not be sized to carry the full calculated load for the unit.
2. Units may be powered via a supply cord as in **Section 550.10**.
3. A disconnecting means within 30 ft. of the unit, as in **550.32(A)**, is not required.
4. Ground rods at each location (as per **Section 250.32**) are not required.

F4 Stairs

Homes that are displayed on dealer lots which will be entered by the public shall have a set of steps at an exterior egress door. Only one set of such steps shall be required. Stair geometry and handrail requirements shall be in accordance with **Section 3.11**, except that pickets or intermediate rails are not required.

APPENDIX G

SAFETY GUIDELINES FOR MANUFACTURED HOME INSTALLATIONS

G1. Use the Truck as an Anchor and Support System

Use the truck to stabilize the home and prevent shifting when possible. This is the easiest and most readily available “anchor” for the home during set-up. With today’s newer hitch systems, the home can easily be maneuvered for set-up and leveling using the truck. This will save time as well as increase safety. When the home is connected to the truck, the chances of shifting are greatly reduced.

G2. Always Use Two or More Jacks with Non-Slip Adapters when Lifting the Home

The jacks used to lift the home should also be approved to lift the required weight. Inspect the jacks before lifting to insure they are in proper working order. Also, jacking should be done from a level surface and no one should be in or on the home when it is being jacked.

G3. Keep Area Around Home Clear of Obstacles. Always Have a Clear Escape Route Around or Under the Home

Should something go wrong, it is imperative that workers have a clear path to safety. Keep any obstacles clear of the work area. Also, if the homeowner is observing, make sure they are well away from the work area as well.

G4. While Home is Being Installed, Cribbing (Safety Blocks or Support Timbers) Must Be Used to Prevent Crushing Injuries

A home is most vulnerable to shifting and falling during the installation process. Safety supports of some type must be used under the home during installation to prevent possible injuries. This includes cribbing, safety blocks, support timbers, and leaving the wheels and axles attached for the entire set-up process.

G5. Make Sure All Employees are Aware of the Danger of Working Between Sections of the Home During Installation

Should the home shift or be moved suddenly, workers may not be able to escape from between the home sections in time to avoid injury. The safest and most effective way to prevent crushing injuries is to completely avoid having body parts between home sections at all times. While this is not always possible during the set-up process, workers should be aware of the serious hazards involved.

G6. No One Should be on the Roof Unless the Home is Connected to the Truck or Anchored and Strapped

The weight of a single person can cause the home to shift, and a shift of as little as a few inches can cause the home to move completely off its piers. The most effective way to avoid this hazard is to keep all workers off of the roof until the home is set.

G7. Additional Key Safety Points to Remember

Keep a well stocked first-aid kit at every job site or in every vehicle.

Follow OSHA fall protection guidelines when working on roofs or other elevated areas.

Recommend steel-toe boot requirements at all construction sites.

Maintain a clean job site, keeping debris and trash neatly piled for disposal away from the work area.

Require eye protection when striking metal to metal or using power tools.

Require hearing protection while power tools are in use.

Make sure all electrical equipment, generators, and tools are grounded.

Properly maintain all tools used in construction. Inspect all tools at the beginning of each day to see that they are in proper working condition.

Keep fire extinguishers at all job sites.

APPENDIX H

SUGGESTED CHECKLIST FOR USE BY LOCAL INSPECTORS

Date of Manufacture: _____

Wind Zone: _____

Thermal (U/O Value): _____

HUD Label: _____

Specifications for Set-Up: State Code _____ Manufacturer's Installation Instructions _____

Over-Height Home: _____

Positive Drainage: _____

Vegetation Under Home Cut to Maximum of 2" Above Grade: _____

All Sod, Stumps, and Organic Materials Removed from Footing Areas: _____

Construction Debris Removed Under Home: _____

Soil Bearing Capacity: _____

Footings: Solid Blocks _____ Pour-in-Place Concrete _____ ABS Pads or other Listed and Labeled Material _____

Footing Size: _____ Footing Depth: _____

Pier Spacing: _____ Pier Height: _____ Single Stacked Piers: _____ Double Stacked Piers: _____

Cap Blocks: _____ Wedges: _____

Marriage Line Pier Location (if required): _____ Perimeter Pier Location (if required): _____

Torque Value of Soil: _____

Anchor Manufacturer: _____ Anchor Model: _____

Anchor Installation: Direct Pull _____ Angled Pull _____ Rock Anchor _____ Concrete Cylinder _____

Stabilizer Plates (if required) _____ Anchor Head Exposed: _____

Approved Tie Strap Material: _____ Strap Angle: _____

Marriage Line Connections: Floor _____ Roof _____ End Walls _____ Ceiling _____

Access to Crawl Space: _____ Tears in Bottom Board Repaired: _____

Skirting Foundation: _____ Skirting Material: _____ Crawl Space Ventilation: _____ Vapor Retarder: _____

Clothes Dryer Vented to Outside: _____

Proper Installation of Crossover Ducts: _____

Utility Connections: Electrical _____ Water Supply _____ DWV System _____ Gas _____

Smoke Detectors: _____

Steps, Landings, Etc.: _____

APPENDIX I

FACTORY BUILT HOME IDENTIFICATION

How Can I Identify the Type of Factory Built Home that I have?

DATA PLATES

Factory Built Home Identification - DATA PLATES

The first and most important piece of information you should try to find regarding your home is the home's Data Plate.

Search the inside of your home to see if you can find the DATA PLATE still attached to it. It will be located permanently attached to your home in a protected location. If you find it, it contains all the information you will need regarding your home.

All Factory Built Homes, both HUD and Modular homes, have a Data Plate permanently attached to them when they are constructed.

Many times Data Plates may have been painted over or removed during home renovations after the initial sale of the home.

What does a Data Plate look like?

Data Plates are normally an 8 1/2"x11" laminated or otherwise protected piece of paper "permanently" glued/attached to the home on the inside of the structure. See **Figures 1 and 2** for Examples of HUD(manufactured homes) Data Plates and **Figures 3 and 4** for MOD(modular homes) Data Plates

Manufacturer Address:
SCHULT HOMES - ROCKWELL
P.O. BOX 200
ROCKWELL, NC 28136

Brand Name: SCHULT
Case of Manufacture: HUD Label No. (A) NTH159825 NTH159825
Plant Number: 00047

Date of Manufacture: 12/11/09
Manufacturer's Serial Number and Model Unit Designation: 001234567890 00 76CAT127644M1

Design Approval by (D.A.P.A.): N/A

CONVERT HEATING
This manufactured home has been factory installed in accordance with the requirements of the Federal Manufactured Home Construction and Safety Standards for all locations within the value zone.

CONVERT COOLING
An air conditioner provided at factory (Alternate 1).

FACTORY INSTALLED EQUIPMENT INCLUDES:

| Equipment | Manufacturer | Model Designation |
|-----------------|--------------|-------------------|
| For heating | N/A | EEB-NLST |
| For air cooling | N/A | JTB60CR08 |
| For cooling | EE | BS2WB0478 |
| Refrigerator | RE | TE-40-2 |
| Washer | N/A | CE |
| Washer Dryer | N/A | CE |
| Dishwasher | CE | BS23N0608 |
| Range/Disposal | ICOR | CS2EMFLC |
| Refrigerator | N/A | JW172R0128 |
| Woolwash tub | CE | |
| MIDWAVE | CE | |

HOME CONSTRUCTED FOR: Zone I Zone II Zone III

DESIGN ROOF LOAD ZONE MAP
North 40 PSF Middle 30 PSF South 20 PSF

UO VALUE ZONE MAP

DESIGN ROOF LOAD ZONE MAP South 20 PSF

Manufacturer Address:
Cavalier Home Builders, LLC
1001 EASTERN AVENUE
P.O. BOX 1007
RAVENHILL, NC 27156

Date of Manufacture: 5/24/11
Manufacturer's Serial Number and Model Unit Designation: 00976 76CAT127644M1

Design Approval by (D.A.P.A.): N/A

CONVERT HEATING
This manufactured home has been factory installed in accordance with the requirements of the Federal Manufactured Home Construction and Safety Standards for all locations within the value zone.

CONVERT COOLING
An air conditioner provided at factory (Alternate 1).

FACTORY INSTALLED EQUIPMENT INCLUDES:

| Equipment | Manufacturer | Model Designation |
|-----------------|--------------|-------------------|
| FOR HEATING | QNT | GS23W028D |
| FOR AIR COOLING | QNT | QD160W080 |
| FOR COOLING | QNT | QD160W080 |
| WASHER | QNT | QD160W080 |
| WASHER DRYER | QNT | QD160W080 |
| WALL OVEN | QNT | QD160W080 |
| MIDWAVE | QNT | QD160W080 |
| COOKTOP | QNT | QD160W080 |
| FRIDGE/FAC 1 | QNT | QD160W080 |
| FRIDGE/FAC 2 | QNT | QD160W080 |
| SHINK ALUMIN | QNT | QD160W080 |

HOME CONSTRUCTED FOR: Zone 1 Zone 2

WIND ZONE MAP

UO VALUE ZONE MAP

DESIGN ROOF LOAD ZONE MAP South 20 PSF

Figure 1 – HUD

Figure 2 – HUD

BUILDING MANUFACTURER'S DATA PLATE

MANUFACTURER: OMH Manufacturing, Inc. DBA: Clayton-Richfield 933
 ADDRESS: Post Office Box 1000
Richfield, NC 28137

BUILDING SERIAL NO.(S): CLF005295XMRAB MODEL NO: MNO603A 1867-8851
 STATE LABEL NO.(S): 56988 DATE OF MANUFACTURE: 7-11-01
 HWC LABEL NO.(S): M70102/M70103 DATE DATA PLATE ATTACHED: 2-17-01

THIS BUILDING IS DESIGNED AND CONSTRUCTED IN COMPLIANCE WITH THE FOLLOWING CODES:

DISCIPLINE: CODE/YEAR AMENDMENT/SUPPLEMENTS
 BUILDING: Vol VII, 1995 CABO 1&2 Family 1997 NC ED W/1998/1999 Rev.
 PLUMBING: Vol VII, 1995 CABO 1&2 Family 1997 NC ED W/1998/1999 Rev.
 GAS: _____
 MECHANICAL: Vol VII, 1995 CABO 1&2 Family 1997 NC ED W/1998/1999 Rev.
 ELECTRICAL: Vol IV, 1999 NEC With 1999 NC Rev.

THIS BUILDING IS DESIGNED FOR THE FOLLOWING CONDITIONS:

USE GROUP/OCCUPANCY: R FLOOR LIVE LOAD (PSF): 40
 CONSTRUCTION TYPE: VI Unprotected ROOF LIVE LOAD (PSF): 20
 FIRE RATING OF EXTERIOR WALLS (HRS.): _____ WIND LOAD (MPH): 100
 SEISMIC ZONE: Category B

U_g FLOOR: .051 U_g WALLS: .082 U_g ROOF/CEILING: .043
 ELECTRICAL SERVICE: 200 AMPS 120/240 VOLTS Single PHASE 60 HZ
 FUEL TYPE: NATURAL GAS LP GAS OTHER Electric
 WATER SYSTEM TEST PRESSURE: 100 PSI

THE FOLLOWING MAJOR APPLIANCES WERE PROVIDED BY THE BUILDING MANUFACTURER:

| APPLIANCE | MANUFACTURER | MODEL |
|------------------|----------------|---------------------|
| HEATING | <u>Nordyne</u> | <u>E2EB015HA</u> |
| AIR CONDITIONING | <u>RHEEM</u> | <u>81V52DC</u> |
| WATER HEATER | <u>GE</u> | <u>JBP66WB4WW</u> |
| RANGE | <u>GE</u> | <u>GSS201EMBWW</u> |
| REFRIG. | <u>GE</u> | <u>GSD3230F00WW</u> |
| D/W | <u>GE</u> | <u>GSD3230F00WW</u> |

NOTICE: THE INSTALLATION OF THIS BUILDING AND UTILITY CONNECTIONS SHOULD BE PERFORMED ONLY BY QUALIFIED PERSONNEL AND IS SUBJECT TO INSPECTION BY LOCAL AUTHORITIES. REFER TO THE APPROVED PLANS FOR REQUIRED ON-SITE WORK AND CONNECTIONS AND TO THE INSTALLATION INSTRUCTIONS PROVIDED BY THE MANUFACTURER. ALL INSTRUCTIONS MUST BE FOLLOWED PRECISELY.

SPECIAL INSTRUCTIONS, LIMITATIONS, ETC.

THIS BUILDING WAS MANUFACTURED UNDER A QUALITY CONTROL SYSTEM MONITORED INDEPENDENTLY BY HILBORN, WERNER, CARTER & ASSOCIATES, INC., 1827 SOUTH MYRTLE AVENUE, CLEARWATER, FLORIDA 34616.

Figure 3 – MOD (modular)

MODULAR DATA PLATE

MANUFACTURER: SCHULT - Plant #957
PO Box 700 / 508 Palmer Rd
Rockwell, NC 28138

APPROVAL AGENCY: NTA, Inc.
305 North Oakland Ave.
Nappanee, IN 46550-0490

Modular Home Model: 3301
 State Label No(s): NC 113419
 NTA, Inc. Label No(s): F2 318921 / F2 - 318922

Modular Home Serial No.: 723427 A/B
 Date Labeled: 01-Dec-09

ELECTRICAL: Service Panel: 200 AMP, 120/240 V., Single Phase, 3 Wire

FACTORY INSTALLED APPLIANCES:

| | MANUFACTURER | MODEL |
|----------------|--------------|--------------|
| Washer | N/A | |
| Clothes Dryer | N/A | |
| Range | GE | JBS07M1BB |
| Water Heater | RHEEM | 82-40-2 |
| Dishwasher | GE | GSD3300R00BB |
| Microwave | N/A | |
| Furnace | GE | E3EB-012H |
| Refrigerator | GE | GTS18DCPX1LB |
| Fireplace | N/A | |
| Whirlpool | N/A | |
| Disposal | N/A | |
| TV | N/A | |
| DVD / Receiver | N/A | |

DESIGN CONDITIONS:

| | | | | | |
|-------------------|----------|----------|-----------------------|------------------|-------|
| Building Area | 1,186 | SQ FT | Wind Load | 90 | MPH |
| Ground Snow Load | 30 | PSF | Building Height | 15 (Single) | STORY |
| Roof Dead Load | 10 | PSF | Seismic Zone | C | |
| Attic Live Load | 10 | PSF | Soil Profile Category | C | |
| Floor Live Load | 40 | PSF | Use Group | R - 3 | |
| Unit Gross Weight | 49,007 | LBS | Construction Type | VB | |
| Water Supply Test | 100 / 15 | PSI/TIME | DWV Test | Air 5 PSI 15 min | |

CODES & STANDARDS:

NC RESIDENTIAL CODES (2009 ED.) NC ELECTRICAL CODES (2008 ED.) W/2008 Amendments
 NC PLUMBING CODES (2009 ED.) NC FUEL GAS CODE (2009 ED.)
 NC MECHANICAL CODES (2009 ED.)

HEATING:

| Design Temperatures: | "R" VALUES |
|--------------------------|--------------------|
| Indoor: <u>69</u> F. | Floor: <u>22</u> |
| Outdoor: <u>1</u> F. | Wall: <u>13</u> |
| Degree Days: <u>3999</u> | Ceiling: <u>30</u> |

SPECIAL INSTRUCTIONS:
HINGED ROOF TO BE COMPLETED ON SET-UP PER MANUFACTURING INSTALLATION MANUAL.

Figure 4 – MOD (modular)

Where are Data Plates normally located?

Kitchen Cabinets

Check around the cabinet area below the Kitchen Sink first.

Glued to the Kitchen Sink Cabinet Door. See Figure 5

Glued just inside the Cabinet beside the Kitchen Sink Cabinet Door. See Figure 6

Glued to the Wall Directly Beneath the Kitchen Sink.

Check the doors of your overhead cabinets. See Figure 7

Clothes Closet

Glued to the Wall of a Clothes Closet – Normally Master bedroom closet. See Figures 8, 9

Electrical Panel Box – Less common location these days



Figure 5

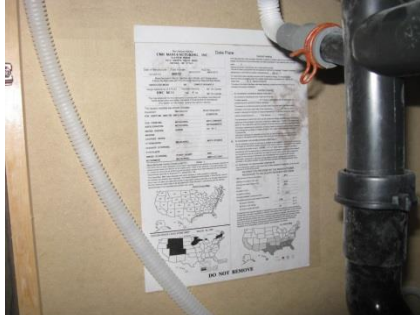

Figure 6



Figure 7



Figure 8

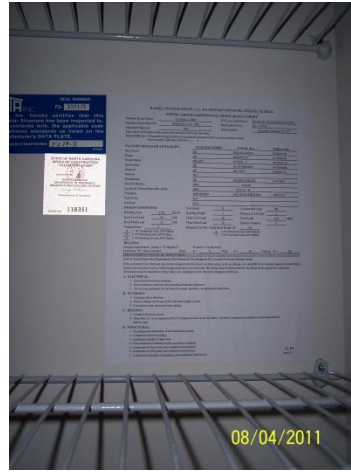

Figure 9

What Information can be found on a Data Plate?

Manufacturer Name and Address

Date of Manufacture

Serial Number

Model Number

Code Certification – Identifies the NC State Building Code or Federal HUD Manufactured Housing Code in effect at time of construction

Design Information – Roof Loads, Floor Loads, Wind Loads

Installed Equipment Information – Type, Brand, Model

Name of the Third Party Certification Agency that approved, inspected, labeled the Home.

HUD Label Number – If Home is a **HUD** Manufactured Home

The First Three Letters of the **HUD** Label number indicates who the Third Party Certification Agency (or State) that Approved, Inspected and Labeled HUD Home

i.e. **NTA, HWC, TRA, RAD, GEO (Georgia), TEN (Tennessee)**, etc.

State Modular Label Number - If Home is a Modular Home

Third Party Agency Modular Certification Label Numbers – If Home is a Modular Home

Special Instructions regarding Home.

I have found my Data Plate, How can I tell if it is a HUD or MOD home?

Your Home IS A HUD Manufactured home:

If “HUD” or Federal Housing and Urban Development are mentioned anywhere on the Data Plate.

If there are three United States Maps on the Data Plate indicating: Basic Wind Zone Map; Basic Roof Design Zone Map; and U/O Value Zone Map (Thermal Zones) See Figure 1 and 2

Your Home IS A MODULAR home:

If the Data Plate indicates any “NC State Label” number on it – Normally only one NC State Label is applied per home regardless of number of modular units.

If the home has a Modular Label from another state, it is still a modular unit. It was just approved and labeled through that state’s modular construction program.

If the Data Plate indicates any Third Party Certification Agency Modular Label Numbers on it.

Normally one 3rd Party Modular Label will be applied on each modular unit.

If Modular is mentioned anywhere on your Data Plate.

If your data plate has no United States maps on it.

If your data plate referenced compliance to volumes of the North Carolina State Building Code. i.e. Residential, Plumbing, Mechanical, Electrical. (or some other State’s Code)

Your Home will be a Pre-HUD mobile home if it was built prior to June 15, 1976 when the HUD program started.

North Carolina had a Mobile Home labeling program which ran from July 1, 1970 until the HUD program started in June 15, 1976. See **Figure 10**

Mobile Homes constructed under the NC Program were constructed to the **USAS A119.1 Standard for Mobile Homes**. See **Figure 11**. This Standard would have been referenced on the home's Data Plate.

On NC labeled Mobile Homes, the data plate would display a Wind Load Map as shown in **Figure 12**.

Other Pre-HUD mobile homes not manufactured under the NC Mobile Home Program were also usually constructed to the **USAS A119.1 Standard for Mobile Homes**. See **Figure 11**. This Standard would have been referenced on the home's Data Plate.

On those other Pre-HUD mobile homes your data plate would also probably display a Wind Load Map as shown in **Figure 12**.

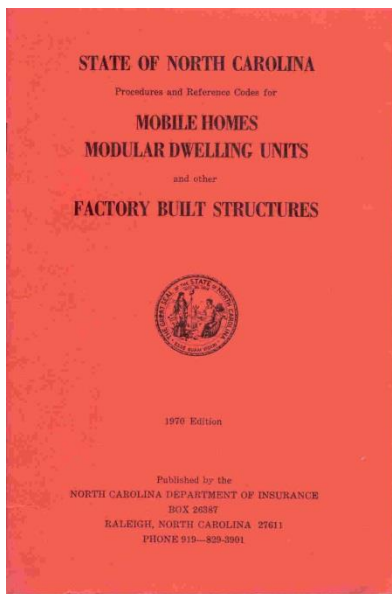

Figure 10

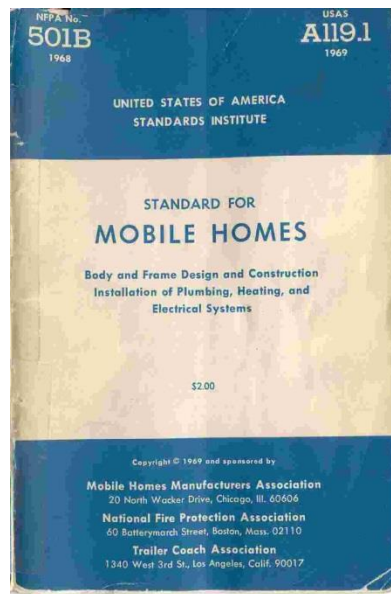

Figure 11

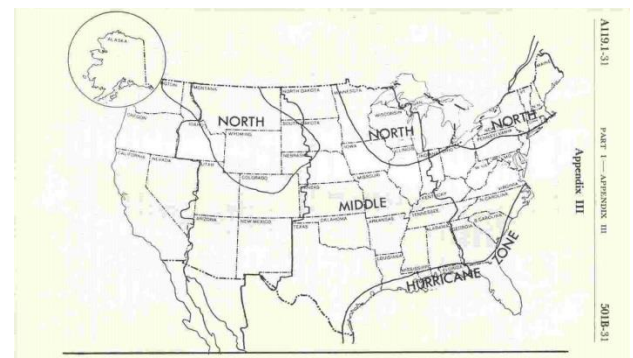

Figure 12

Depending upon the age of your HUD Manufactured Home, you may be able to obtain a replacement DATA PLATE from the home's manufacturer or from the HUD approved Third Party Certification Agency (PIA) or from IBTS (Institute for Building Technology and Safety)(a HUD subcontractor) may be able to provide you additional information regarding your HUD home. www.IBTS.org (703-481-2000)

Depending upon the age of your Modular Home, you may be able to obtain a replacement DATA PLATE from the home's Manufacturer or the home's NC approved Third Party Certification Agency.

North Carolina began collecting copies of Data Plates on all Modular homes manufactured since August 2010. We will be able to provide you a replacement copy of your Data Plate if your home was manufactured since that time period. **Manufactured Building Division of the NC Department of Insurance**. (919-647-0000) www.ncosfm.gov/manufactured-building

LABELS

Search the inside and outside of your home to see what kind of Labels that are still attached to it.

HUD Manufactured Home – HUD Label

A HUD label is a certification label that certifies that the manufactured home was constructed and inspected in the plant and that it conforms to the Federal Manufactured Home Construction and Safety Standards.

(See **Figures 13 and 14**)

If you find a HUD label on your home, it is a HUD manufactured home (formally called a mobile home, or trailer). A HUD label is an approximately 2"x4" painted red aluminum metal plate with the HUD certification and label number etched into it. It is "permanently" attached to the outside of the unit (see **Figure 13**). Over time, the red paint can fade out to a gray/silver look. (See **Figure 14**)



Figure 13



Figure 14

HUD Label Number – If Home is a HUD Manufactured Home

The First Three Letters of the HUD Label number indicates who the HUD approved Primary Inspection Agency (or State) that Inspected and Labeled the HUD Home in the plant.

Examples: **HWC** = Hilborn, Werner, Carter & Associates, Inc.; **PFS** = PFS Corporation; **NTA** = NTA, Inc.; **RAD** = RADCO; **TRA** = T. R. Arnold and Associates, Inc.; **GEO** = the state of Georgia; **TEN** = the state of Tennessee; etc.

Figure 13 was inspected by the State of Tennessee (TEN), **Figure 14** was inspected by RADCO (RAD)

If you have a HUD Label number, you can use the first three letters of the HUD Label number to identify the HUD approved Primary Inspection Agency that inspected that home.

The Primary Inspection Agency may be able to provide you additional information regarding your home. Contact Information Below:

FLORIDA - IPIA

James McGowan

Field Services Manager

State of Florida

Department of Highway Safety and Motor Vehicles

Division of Motorist Services

Manufactured Housing Section

5701 East Hillsborough Avenue, Suite 2228

Tampa, FL 33610

PH: 813-612-7150

FAX: 813-612-7131

Email: jamesmcgowan@flhsmv.gov

GEORGIA - IPIA

W.T. Hickox
Manufactured Housing Section
Floyd Building, West Tower, Suite 620
2 Martin Luther King, Jr. Drive
Atlanta, GA 30334-9000
PH: 404-227-4304
FAX: (404) 657-6971
Email: whickox@sfm.ga.gov

HWC - IPIA

Travis Woodward
Vice President, IPIA Director
Director of HUD Inspection Services
Hilborn, Werner, Carter and
Associates, Inc. (HWC)
1627 South Myrtle Avenue
Clearwater, FL 33756-1131
PH: (727) 584-8151
FAX: (727) 587-0447
Email: twoodward@hwceng.com

NTA - IPIA

David A. Tompos
President
NTA, Inc.
305 North Oakland Avenue
P.O. Box 490
Nappanee, IN 46550-2341
PH: (574) 773-7975
FAX: (574) 773-2732
Email: tompos@ntainc.com
Website: www.ntainc.com

PFS - IPIA

Robert Gorleski, GM of Manufactured Structures
PFS Corporation
1507 Matt Pass
Cottage Grove, WI 53527-8962
PH:(608) 839-1393
FAX: (608) 839-1014
Email: rgorleski@pfscorporation.com

RADCO - IPIA

Kim Rose
18071 Mount Washington St.
Fountain Valley, CA 92708
PH: (562) 272-7231
Fax: (562) 529-7513
Email: info@radcoinc.com

TENNESSEE - IPIA

Charles M. Chambers, Director
Manufactured Housing Section
Tennessee State Fire Marshal's Office
Tennessee Department of Commerce and Insurance
Division of Fire Prevention
500 James Robertson Parkway
Nashville, TN 37243
PH: (615) 253-5317
FAX: (615) 741-9388
Email: charles.chambers@tn.gov

TRA - IPIA

Jeffrey A. Clouse
President and Chief Operating Officer
T. R. Arnold and Associates, Inc.
4703 Chester Drive
Elkhart, IN 46516
PH: 574-264-0745
Fax: 574-264-0740
Email: jclouse@trarnold.com

HUD homes will have one HUD label attached to each transportable section.

All HUD Label numbers will be listed on the home's Data Plate.

The HUD Label is required to be attached approximately one foot above the floor level and approximately one foot from the end of the unit which is opposite the end of the unit where the hitch was attached to the frame.

Single wide homes will be label on the end of the home opposite the hitch. (see **Figure 15**)

Double wide homes – Each section will be labeled on the front or back side of the home, opposite the hitch end. (see **Figure 16**)



Figure 15



Figure 16

Other than a Data Plate, which is common to all factory built structures, the HUD Label is the ONLY label you will find on a HUD labeled home. If you find other types of labels, you may have something other than a HUD home. Further investigation will be required.

On August 11, 1982, the name changed at the Federal level from Mobile Home to Manufactured Home to reflect the more permanent nature of the homes being constructed.

The Federal Mobile Home Program became the Federal Manufactured Housing Program.

The Federal Mobile Home Construction and Safety Standards became the Federal Manufactured Housing Construction and Safety Standards. The Federal Program itself did not change.

If you have a HUD Label number, the **Manufactured Building Division of the NC Department of Insurance** may be able to provide you additional information regarding your home. (919-647-0000)

www.ncosfm.gov/manufactured-building

If you have a HUD Label number, IBTS (Institute for Building Technology and Safety) (a HUD subcontractor) may be able to provide you additional information regarding your HUD home. www.IBTS.org (703-481-2000)

Pre-HUD Mobile Homes Labels – NC Labeled Mobile Homes

The HUD Federal Mobile Home Program started on June 15, 1976. Homes constructed prior to that date are commonly referred as pre-HUD homes.

North Carolina had a Mobile Home labeling program before the HUD Mobile Home Program which ran from July 1, 1970 until the HUD program started in June 15, 1976.

Mobile Homes labeled under this program during that time period displayed a NC Mobile Home Validating Stamp on it as shown in **Figure 17**.

NC Mobile Home Validating Stamps were required to be located adjacent to the home's Data Plate.

See **Figure 18**.



**NC Mobile Home
Validating Stamp
July 1, 1970 - June 15, 1976**

Figure 17

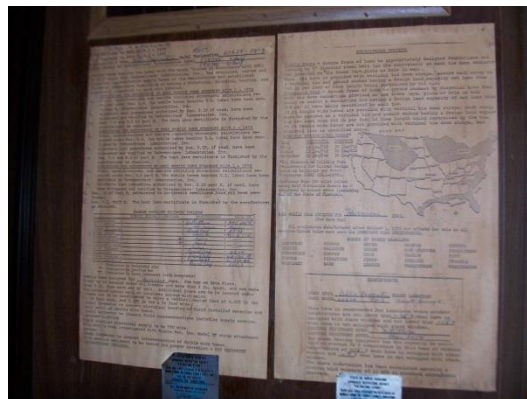

Figure 18

Modular Homes – Modular Construction Validating Stamps – Modular Labels

A North Carolina Modular Construction Validating Stamp is a certification label that certifies that the modular home was constructed and inspected in the plant and that it conforms to the North Carolina Modular Construction Program and the North Carolina State Building Code in effect at the time of construction. (For Examples See **Figures 19, 20, 21, and 22**)



NC Validating Stamp
Used on Modular Homes from
July 1, 1970 - February 1, 1986

Figure 19



NC Modular Construction
Validating Stamp
Used since February 1, 1986

Figure 20



Figure 21

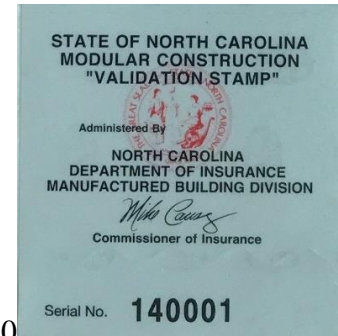

Figure 22

A North Carolina Modular label is approximately 2"x2" with a NC State Seal on a reflective silver background. It is required to be "permanently" attached on the inside of the home directly adjacent to the home's data plate. For one and two family dwelling units, there will be Only One NC Modular Label for each dwelling unit. A duplex home would have two modular labels, one for each dwelling unit.

The Modular Label number will be listed on the home's Data Plate. If you find a Modular label on your home, it is a Modular home. Modular homes which have been labeled through another state's modular program will have that state's modular label(s) attached to it. It is still a modular home. It was constructed to that State's Building Code requirements. Placement in North Carolina is subject to approval by the local NC building official.

If you have a NC Modular Construction Validating Stamp number, the **Manufactured Building Division of the NC Department of Insurance** may be able to provide you additional information regarding your home. (919-647-0000) www.ncosfm.gov/manufactured-building

Modular Homes – Third Party Certification Agency Labels – (3rd Party Labels)

A Third Party Certification Agency Label is a certification label that certifies that the modular home was constructed and inspected in the plant by the 3rd Party Inspection Agency and that it conforms to the North Carolina Modular Construction Program and the North Carolina State Building Code. (See **Figures 23, 24, 25, 26, 27, 28, 29, 30, and 31** for examples of Third Party Labels.)



Figure 23



Figure 24



Figure 25

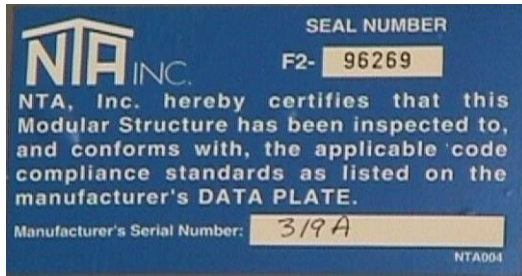

Figure 26

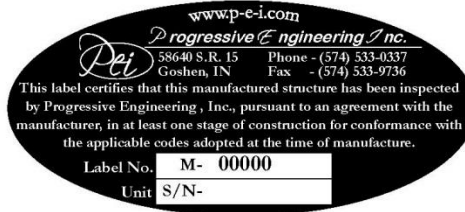

Figure 27



Figure 28

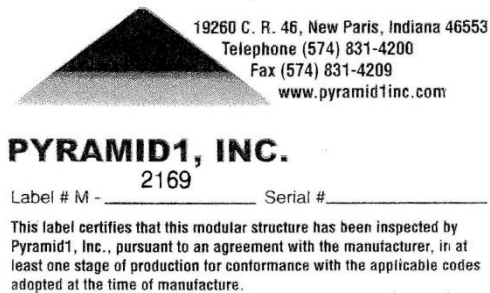

Figure 29



Figure 30

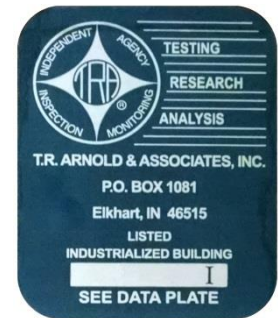

Figure 31

A Third Party Certification Agency Modular Label can be any size, shape, or color but is normally around 2"x2" or 2"x3". Each Third Party Certification Agency Modular Label will have a unique number which is assigned to that home. Each Third Party Certification Agency Modular Label numbers will be listed on the home's Data Plate. One Third Party Certification Agency Modular Label is required to be "permanently" attached on the inside of each of the modular sections. They could be placed anywhere in that modular section. If there is not an appropriate place to locate the Third Party Certification Agency Label in a modular unit, you may find that the manufacturer may have placed that label adjacent to the home's Data Plate. You will NOT find a Third Party Certification Agency Modular Label on a HUD Home. If you find a Third Party Certification Agency Modular Label on your home, it is a Modular home. If you have a Third Party Certification Agency Modular Label number, the Third Party Agency may be able to provide you additional information regarding your Modular home. 3rd Party Modular Agencies may be contacted at the following:

Expert Modular Consultants 13103 W. Linebaugh Ave Tampa FL 33626 Mr. Robert A. Johnson (813) 294-4412

HWCNC, P.C. 1627 S. Myrtle Avenue Clearwater FL 33756-1131 Mr. Scott Francis, P.E. (727) 584-8151 (727) 586-3343

Intertek Modular Solutions 1748 33rd Street Orlando FL 32839 Mr. Ryan Knowles (407) 304-5560 (321) 201-8079

ICC- NTA, LLC 305 N. Oakland Avenue Nappanee IN 46550 Mr. Chuck Osterday (574) 773-7975 (574) 773-2732

PFS-TECO 1507 Matt Pass Cottage Grove WI 53527 Mr. Bob Gorleski (608) 839-1013 (608) 839-1014

ICC-PEI, LLC 58640 State Road 15 Goshen IN 46528 Mr. Ian Henderson (574) 533-0337 (574) 533-9736

PYRAMID1, Inc. P.O. Box 463, 19260 C.R. 46 New Paris IN 46553 Mr. Andrew R. Carlson (574) 831-4200 (574) 831-4209

RADCO, Inc. 18071 Mount Washington St. Fountain Valley CA 92708 Mr. Randy Saunders (336) 879-4788 (336) 953-9046

T.R. Arnold & Assoc., Inc. 4703 Chester Dr. Elkhart IN 46516 Mr. Joseph Mullins (574) 264-0745 (574) 264-0740

If you have a Third Party Certification Agency Modular Label number, the Manufactured Building Division of the NC Department of Insurance may be able to provide you additional information regarding your home. (919-647-0000) www.ncosfm.gov/manufactured-building

SERIAL NUMBERS

Factory Built Home Identification – Serial Numbers

Every factory built home is assigned a SERIAL NUMBER by the manufacturer. This is true for both HUD and Modular homes.

Example: a two section home might have a serial number such as 123456AB – Note: the A and B indicates an A section and a B section and that this is a two section home. A three section home will have a C section and the serial number would be 123456ABC.

Each transportable section of the home will have its own unique serial number. Normally it is the home's serial followed by an A, B, C, etc. depending on the number of sections it takes to make up the entire home. For a two section home, the serial numbers of the A and B sections will be 123456A and 123456B.

The serial number will be indicated inside the house on the home's DATA PLATE. Normally it the home serial number followed by A, B, C, etc. as needed to indicate each section of the home. For the same two section home, the serial number on the DATA PLATE will be 123456AB.

For HUD Homes ONLY, the serial number is required to be stamped into the steel cross member that the hitch is attached to for each section of the home. For on-frame Modular Homes, you may find the serial number stamped into the cross members but it is not required. Off-frame Modular Homes do not have steel frames and therefore you will not find a serial number at this location. (see **Figures 32, 33, 34, 35, 36, 37**)



Figure 32



Figure 33

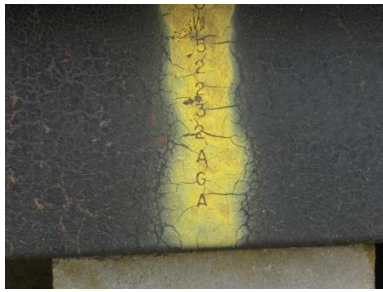

Figure 34



Figure 35



Figure 36



Figure 37

Over time these serial numbers may be difficult to read.

When an HUD Manufactured Home or an on-frame Modular home is set on a masonry foundation it will be difficult to see the serial number on the cross member due to the closeness of the cross member to the perimeter masonry curtain wall.

If a DMV Title was ever issued for your home, most times the VIN number on the Title is the same as the serial number of your home. Contact your local DMV office if you need Title assistance.

If you have a HUD SERIAL NUMBER, IBTS (Institute for Building Technology and Safety) (a HUD subcontractor) may be able to provide you additional information regarding your HUD home. www.IBTS.org (703-481-2000)

If you have a SERIAL NUMBER, the **Manufactured Building Division of the NC Department of Insurance** may be able to provide you additional information regarding your home. (919-647-0000)

www.ncosfm.gov/manufactured-building

Sources for Obtaining Information

The best place to obtain information regarding your home is with the manufacturer. The manufacturer creates a file for each home produced which contains such items as production order, approved plans, QA check sheets, copy of the Data Plate, etc. This file is commonly called the Service File and is normally kept in the Service Department at the plant facility which constructed your home. After a set period of years, these files may be destroyed. If the plant facility which produced your home has closed, these service files may have been transferred to another nearby plant facility of the same company or they may have been moved to the corporate office. If your plant facility has closed and there is no corporate office, then your home's service file has probably been destroyed or discarded. You should be able to get a replacement copy of your home's Data Plate from the manufacturer if you can locate your home's service file.

The manufacturer's Third Party Certification Agency (MOD) or Primary Inspection Agency (HUD) may be able to assist you in obtaining information about your home if you can determine the name of that agency and you can provide them with some basic information regarding your home which they can use to look up in their records. The more information you can provide them the better. i.e. manufacturer's name, serial number, HUD label number, 3rd Party Mod Label number, State Modular Label number, etc. You may be able to get a replacement copy of your home's Data Plate from the 3rd Party Agency if they kept a copy in their records. Contact information is listed above.

For HUD homes, IBTS (Institute for Building Technology and Safety), a HUD subcontractor, should be able to provide you information regarding your home if you can provide them with some basic information regarding your home which they can use to look up in their records. Depending on the age of your home, you should be able to get a replacement copy of your home's Data Plate from IBTS. IBTS can be contacted at www.IBTS.org or 703-481-2000.

APPENDIX J

GENERAL STATUTES

Article 9A.

North Carolina Manufactured Housing Board – Manufactured Home Warranties.

Part 1. Duties, Warranties, Purchase Transaction.

§ 143-143.8. Purpose.

The General Assembly finds that manufactured homes have become a primary housing resource for many of the citizens of North Carolina. The General Assembly finds further that it is the responsibility of the manufactured home industry to provide homes which are of reasonable quality and safety and to offer warranties to buyers that provide a means of remedying quality and safety defects in manufactured homes. The General Assembly also finds that it is in the public interest to provide a means for enforcing such warranties.

Consistent with these findings and with the legislative intent to promote the general welfare and safety of manufactured home residents in North Carolina, the General Assembly finds that the most efficient and economical way to assure safety, quality and responsibility is to require the licensing and bonding of all segments of the manufactured home industry. The General Assembly also finds that it is reasonable and proper for the manufactured home industry to cooperate with the Commissioner of Insurance, through the establishment of the North Carolina Manufactured Housing Board, to provide for a comprehensive framework for industry regulations. (1981, c. 952, s. 2; 1999-393, s. 1; 2005-451, s. 1.)

§ 143-143.9. Definitions.

The following definitions apply in this Part:

- (1) Bank. – A federally insured financial institution including institutions defined under G.S. 53C-1-4(4), savings and loan associations, credit unions, savings banks and other financial institutions chartered under this or any other state law or chartered under federal law.
- (1a) Board. – The North Carolina Manufactured Housing Board.
- (2) Buyer. – A person for whom a dealer performs, or is engaged to perform, any services or provides any products including the purchase and setup of a manufactured home for use as a residence or other related use.
- (3) Code. – Engineering standards adopted by the Commissioner.
- (4) Commissioner. – The Commissioner of Insurance of the State of North Carolina.
- (5) Department. – The Department of Insurance of the State of North Carolina.
- (5a) Deposit. – Any and all funds received by a dealer from a buyer or someone on behalf of a buyer for the performance of services or the provision of goods.
- (5b) Escrow or trust account. – An account with a bank that is designated as an escrow account or as a trust account and that is maintained by a dealer for the deposit of buyers' funds.
- (5c) Escrow or trust account funds. – Funds belonging to a person other than the dealer that are received by or placed under the control of the dealer in connection with the performance of services or the provision of products by a dealer for a buyer.
- (5d) Funds. – Any form of money, including cash, payment instruments such as checks, money orders, or sales drafts, and receipts from electronic fund transfers. The term does not include letters of credit or promissory notes.
NC General Statutes - Chapter 143 Article 9A 2
- (5e) License. – A license issued under this Part.
- (5f) Licensee. – A person who has been issued a license under this Part by the North Carolina Manufactured Housing Board.
- (6) Manufactured home. – A structure, transportable in one or more sections, which, in the traveling mode, is eight feet or more in width or is 40 feet or more in length, or when erected on site, is 320 or more square feet, and which is built on a permanent chassis and designed to be used as a dwelling with or without a permanent foundation when connected to the required utilities, and includes the plumbing, heating, air conditioning and electrical systems contained therein.

(7) Manufactured home dealer or dealer. – Any person engaged in the business of buying or selling manufactured homes or offering or displaying manufactured homes for sale in North Carolina. Any person who buys or sells three or more manufactured homes in any 12-month period, or who offers or displays for sale three or more manufactured homes in any 12-month period shall be presumed to be a manufactured home dealer. The terms "selling" and "sale" include lease-purchase transactions. The term "manufactured home dealer" does not include banks and finance companies that acquire manufactured homes as an incident to their regular business.

(8) Manufactured home manufacturer or manufacturer. – Any person, resident or nonresident, who manufactures or assembles manufactured homes for sale to dealers in North Carolina.

(9) Manufactured home salesperson or salesperson. – Any person employed by a manufactured home dealer to sell manufactured homes to buyers. Manufactured home salesperson or salesperson also includes sales managers, lot managers, general managers, or others who manage or supervise salespersons.

(10) Person. – Any individual, natural persons, firm, partnership, association, corporation, legal representative or other recognized legal entity.

(11) Responsible party. – A manufacturer, dealer, supplier, or set-up contractor.

(12) Setup. – The operations performed at the occupancy site which render a manufactured home fit for habitation.

(13) Set-up contractor. – A person who engages in the business of performing setups for compensation in North Carolina.

(14) Substantial defect. – Any substantial deficiency in or damage to materials or workmanship occurring in a manufactured home which has been reasonably maintained and cared for in normal use. The term also means any structural element, utility system or component part of the manufactured home which fails to comply with the Code.

(15) Supplier. – The original producer of completed components, including refrigerators, stoves, hot water heaters, dishwashers, cabinets, air conditioners, heating units, and similar components, and materials such as floor coverings, paneling, siding, trusses, and similar materials, which are furnished to a manufacturer or dealer for installation in the manufactured home prior to sale to a buyer. (1981, c. 952, s. 2; 1987, c. 429, ss. 4, 5, 19; 1999-393, s. 1; 2001-421, s. 2.1.; 2005-451, ss. 1, 2; 2012-56, s. 48.)

§ 143-143.10. Manufactured Housing Board created; membership; terms; meetings. NC General Statutes - Chapter 143 Article 9A 3

(a) There is created the North Carolina Manufactured Housing Board within the Department. The Board shall be composed of 11 members as follows:

(1) The Commissioner of Insurance or the Commissioner's designee.

(2) A manufactured home manufacturer.

(3) A manufactured home dealer.

(4) A representative of the banking and finance industry.

(5) A representative of the insurance industry.

(6) A manufactured home supplier.

(7) A set-up contractor.

(8) Two representatives of the general public.

(9) A person who is employed with a HUD-approved housing counseling agency in the State.

(10) An accountant.

The Commissioner or the Commissioner's designee shall chair the Board. The Governor shall appoint to the Board the manufactured home manufacturer and the manufactured home dealer. The General Assembly upon the recommendation of the Speaker of the House of Representatives in accordance with G.S. 120-121 shall appoint to the Board the representative of the banking and finance industry, the employee of a HUD-approved housing counseling agency, and the representative of the insurance industry. The General Assembly upon the recommendation of the President Pro Tempore of the Senate in accordance with G.S. 120-121 shall appoint to the Board the manufactured home supplier, the accountant, and the set-up contractor. The Commissioner shall appoint two representatives of the general public. Except for the representatives from the general public and the persons appointed by the

General Assembly, each member of the Board shall be appointed by the appropriate appointing authority from a list of nominees submitted to the appropriate appointing authority by the Board of Directors of the North Carolina Manufactured and Modular Homebuilders Association. At least three nominations shall be submitted for each position on the Board. The members of the Board shall be residents of the State. The members of the Board shall serve for terms of three years. In the event of any vacancy of a position appointed by the Governor or Commissioner, the appropriate appointing authority shall appoint a replacement in the same manner as provided for the original appointment to serve the remainder of the unexpired term. Vacancies in appointments made by the General Assembly shall be filled in accordance with G.S. 120-122. In the event of any vacancy, the appropriate appointing authority shall appoint a replacement to serve the remainder of the unexpired term. Such appointment shall be made in the same manner as provided for the original appointment. No member of the Board shall serve more than two consecutive, three-year terms.

The members of the Board designated in subdivisions (8), (9), and (10) of this subsection shall have no current or previous financial interest connected with the manufactured housing industry. No member of the Board shall participate in any proceeding before the Board involving that member's own business. Each member of the Board, except the Commissioner and any other State employee, shall receive per diem and allowances as provided with respect to occupational licensing NC General Statutes - Chapter 143 Article 9A 4 boards by G.S. 93B-5. Fees collected by the Board under this Article shall be credited to the Insurance Regulatory Fund created under G.S. 58-6-25.

(b) In accordance with the provisions of this Part, the Board shall have the following powers and duties:

- (1) To issue licenses to manufacturers, dealers, salespersons, and set-up contractors.
- (2) To require that an adequate bond or other security be posted by all licensees, except manufactured housing salespersons.
- (3) To receive and resolve complaints from buyers of manufactured homes and from persons in the manufactured housing industry, in connection with the warranty, warranty service, licensing requirements or any other provision under this Part.
- (4) To adopt rules in accordance with Chapter 150B of the General Statutes as are necessary to carry out the provisions of this Part.
- (5) To file against the bond posted by a licensee for warranty repairs and service on behalf of a buyer.
- (6) To request that the Department of Public Safety conduct criminal history checks of applicants for licensure pursuant to G.S. 143B-944.
- (7) To conduct random audits of dealer escrow or trust accounts. (1981, c. 952, s. 2; 1983, c. 717, ss. 107-109, 114; 1987, c. 429, ss. 6, 7, 19, c. 827, s. 1; 1999-393, s. 1; 2002-144, s. 4; 2003-221, s. 1; 2003-400, s. 9; 2005-451, ss. 1, 3; 2011-330, s. 47(b); 2014-100, s. 17.1(jjj); 2018-120, s. 4.8.)

§ 143-143.10A. Criminal history checks of applicants for licensure.

(a) Definitions. – The following definitions shall apply in this section:

- (1) Applicant. – A person applying for initial licensure as a manufactured home salesperson or set-up contractor.
- (2) Criminal history. – A history of conviction of a state or federal crime, whether a misdemeanor or felony, that bears on an applicant's fitness for licensure under this Part. The crimes include the criminal offenses set forth in any of the following Articles of Chapter 14 of the General Statutes: Article 5, Counterfeiting and Issuing Monetary Substitutes; Article 5A, Endangering Executive and Legislative Officers; Article 6, Homicide; Article 7B, Rape and Other Sex Offenses; Article 8, Assaults; Article 10, Kidnapping and Abduction; Article 13, Malicious Injury or Damage by Use of Explosive or Incendiary Device or Material; Article 14, Burglary and Other Housebreakings; Article 15, Arson and Other Burnings; Article 16, Larceny; Article 17, Robbery; Article 18, Embezzlement; Article 19, False Pretenses and Cheats; Article 19A, Obtaining Property or Services by False or Fraudulent Use of Credit Device or Other Means; Article 19B, Financial Transaction Card Crime Act; Article 20, Frauds; Article 21, Forgery;

Article 26, Offenses Against Public Morality and Decency; Article 26A, Adult Establishments; Article 27, Prostitution; Article 28, Perjury; Article 29, Bribery; Article 31, Misconduct in Public Office; Article 35, Offenses

Against the Public Peace; Article 36A, Riots, Civil Disorders, and Emergencies; Article 39, Protection of Minors; Article 40, Protection of the Family; Article 59, Public Intoxication; and Article 60, NC General Statutes - Chapter 143 Article 9A 5 Computer-Related Crime. The crimes also include possession or sale of drugs in violation of the North Carolina Controlled Substances Act in Article 5 of Chapter 90 of the General Statutes and alcohol-related offenses including sale to underage persons in violation of G.S. 18B-302 or driving while impaired in violation of G.S. 20-138.1 through G.S. 20-138.5. In addition to the North Carolina crimes listed in this subdivision, such crimes also include similar crimes under federal law or under the laws of other states.

(b) All applicants for initial licensure shall consent to a criminal history record check. Refusal to consent to a criminal history record check may constitute grounds for the Board to deny licensure to an applicant. The Board shall ensure that the State and national criminal history of an applicant is checked. Applicants shall obtain criminal record reports from one or more reporting services designated by the Board to provide criminal record reports. Each applicant is required to pay the designated service for the cost of the criminal record report. In the alternative, the Board may provide to the North Carolina Department of Public Safety the fingerprints of the applicant to be checked, a form signed by the applicant consenting to the criminal record check and the use of fingerprints and other identifying information required by the State or National Repositories of Criminal Histories, and any additional information required by the Department of Public Safety. The Board shall keep all information obtained pursuant to this section confidential.

(c) If an applicant's criminal history record check reveals one or more convictions listed under subdivision (a)(2) of this section, the conviction shall not automatically bar licensure. The Board shall consider all of the following factors regarding the conviction:

- (1) The level of seriousness of the crime.
- (2) The date of the crime.
- (3) The age of the person at the time of the conviction.
- (4) The circumstances surrounding the commission of the crime, if known.
- (5) The nexus between the criminal conduct of the person and the job duties of the position to be filled.
- (6) The person's prison, jail, probation, parole, rehabilitation, and employment records since the date the crime was committed.
- (7) The subsequent commission by the person of a crime listed in subdivision (a)(2) of this section.

If, after reviewing these factors, the Board determines that the applicant's criminal history disqualifies the applicant for licensure, the Board may deny licensure of the applicant. The Board may disclose to the applicant information contained in the criminal history record check that is relevant to the denial. The Board shall not provide a copy of the criminal history record check to the applicant. The applicant shall have the right to appear before the Board to appeal the Board's decision. However, an appearance before the full Board shall constitute an exhaustion of administrative remedies in accordance with Chapter 150B of the General Statutes.

(d) Limited Immunity. – The Board, its officers, and employees, acting in good faith and in compliance with this section, shall be immune from civil liability for denying licensure to an applicant based on information provided in the applicant's criminal history record check. (2003-400, s. 8; 2005-451, s. 1; 2007-416, s. 1; 2012-12, s. 2(vv); 2014-100, s. 17.1(o); 2015-181, s. 47; 2015-286, s. 2.2.) NC General Statutes - Chapter 143 Article 9A 6

§ 143-143.11. License required; application for license.

(a) It shall be unlawful for any manufactured home manufacturer, dealer, salesperson, or set-up contractor to engage in business as such in this State without first obtaining a license from the Board for each place of business operated by the licensee, as provided in this Part. The fact that a person is licensed by the Board as a set-up contractor or a dealer does not preempt any other licensing boards' applicable requirements for that person.

- (b) Application for the license shall be made to the Board at such time, in such form, and contain information the Board requires, and shall be accompanied by the fee established by the Board. The fee shall not exceed three hundred fifty dollars (\$350.00) for each license issued. In addition to the license fee, the Board may also charge an applicant a fee to cover the cost of the criminal history record check required by G.S. 143-143.10A.
- (c) In the application, the Board shall require information relating to the matters set forth in G.S. 143-143.13 as grounds for refusal of a license, and information relating to other pertinent matters consistent with safeguarding the public interest. All of this information shall be considered by the Board in determining the fitness of the applicant. Once the Board has determined that an applicant is fit, the Board must provide the applicant a license for each place of business operated by the applicant.
- (d) All licenses shall expire, unless revoked or suspended, on June 30 of each year following the date of issue.
- (e) Every licensee shall, on or before the first day of July of each year, obtain a renewal of a license for the next year by applying to the Board, completing the necessary hours of continuing education required under G.S. 143-143.11B, and paying the required renewal fee for each place of business operated by the licensee. The renewal fee shall not exceed three hundred fifty dollars (\$350.00) for each license issued. Upon failure to renew by the first day of July, a license automatically expires. The license may be renewed at any time within one year after its lapse upon payment of the renewal fee and a late filing fee. The late filing fee shall not exceed three hundred fifty dollars (\$350.00).
- (f) Repealed by Session Laws 2005-297, s. 1, effective August 22, 2005.
- (g) Notwithstanding the provisions of subsection (a), the Board may provide by rule that a manufactured home salesperson will be allowed to engage in business during the time period after making application for a license but before such license is granted.
- (h) As a prerequisite to obtaining a license under this Part, a person may be required to pass an examination prescribed by the Board that is based on the Code, this Part, and any other subject matter considered relevant by the Board. (1981, c. 952, s. 2; 1985, c. 487, s. 1; 1987, c. 429, s. 19; 1987 (Reg. Sess., 1988), c. 1039, ss. 2, 3; 1989, c. 485, s. 44; 1991, c. 644, s. 35; 1999-393, s. 1; 2003-400, s. 10; 2005-297, s. 1.; 2005-451, s. 1; 2009-451, s. 21.4.)

§ 143-143.11A. Notification of change of address, control of ownership, and bankruptcy.

- (a) Every applicant for a license shall inform the Board of the applicant's business address. Every licensee shall give written notification to the Board of any change in the licensee's business address, for whatever reason, within 10 business days after the licensee moves to a new address or a change in the address takes place. A violation of this subsection shall not constitute grounds for revocation, suspension, or non-renewal of a license or for the imposition of any other penalty by the Board.
- (b) Notwithstanding any other provision of law, whenever the Board is authorized or required to give notice to a licensee under this Part, the notice may be delivered personally to the NC General Statutes - Chapter 143 Article 9A 7 licensee or sent by first-class mail to the licensee at the address provided to the Board under subsection (a) of this section. Notice shall be deemed given four days after mailing, and any Department employee may certify that notice has been given.
- (c) Every person licensed under this Part, except for a person licensed as a manufactured home salesperson, shall give written notification to the Board of any change in ownership or control of the licensee's business within 30 business days after the change. A "change in ownership or control" means the sale or conveyance of the capital stock of the business or of an owner's interest in the business, which operates to place a person or group of persons, not previously in control of the business, in effective control of the business. A violation of this subsection shall not constitute grounds for revocation, suspension, or nonrenewal of a license or for the imposition of any other penalty by the Board.
- (d) Upon the filing for protection under the United States Bankruptcy Code by any licensee, or by any business in which the licensee holds a position of employment, management or ownership, the licensee shall notify the Board of the filing of protection within three business days after the filing. Upon the appointment of a receiver by a court of this State for any licensee, or for any business in which the licensee holds a position of employment, management, or ownership the licensee shall notify the Board of the appointment within three business days after the appointment. (1999-393, s. 1; 2000-122, s. 9; 2005-451, s. 1.)

§ 143-143.11B. Continuing education.

- (a) The Board may establish programs and requirements of continuing education for licensees, but shall not require licensees to complete more than eight credit hours of continuing education. Before the renewal of a

license, a licensee shall present evidence to the Board that the licensee has completed the required number of continuing education hours in courses approved by the Board during the two months immediately preceding the expiration of the licensee's license. No member of the Board shall provide or sponsor a continuing education course under this section while that person is serving on the Board.

(b) The Board may establish nonrefundable fees for the purpose of providing staff and resources to administer continuing education programs, and may establish nonrefundable course application fees, not to exceed one hundred fifty dollars (\$150.00), for the Board's review and approval of proposed continuing education courses. The Board may charge the sponsor of an approved course a nonrefundable fee not to exceed seventy-five dollars (\$75.00) for the annual renewal of course approval. The Board may also require a course sponsor to pay a fee, not to exceed five dollars (\$5.00) per credit hour per licensee, for each licensee completing an approved continuing education course conducted by the sponsor. The Board may award continuing education credit for a course that has not been approved by the Board or for related educational activity and may prescribe the procedures for a licensee to submit information on the course or related educational activity for continuing education credit. The Board may charge the licensee a fee not to exceed fifty dollars (\$50.00) for each course or activity submitted.

(c) The Board may adopt any reasonable rules not inconsistent with this Part to give purpose and effect to the continuing education requirement, including rules that govern:

- (1) The content and subject matter of continuing education courses.
- (2) The criteria, standards, and procedures for the approval of courses, course sponsors, and course instructors.
- (3) The methods of instruction.
- (4) The computation of course credit. NC General Statutes - Chapter 143 Article 9A 8
- (5) The ability to carry forward course credit from one year to another.
- (6) The waiver of or variance from the continuing education requirement for hardship or other reasons.
- (7) The procedures for compliance and sanctions for noncompliance.

(d) The license of any person who fails to comply with the continuing education requirements under this section shall lapse. The Board may, for good cause shown, grant extensions of time to licensees to comply with these requirements. Any licensee who, after obtaining an extension, offers evidence satisfactory to the Board that he or she has satisfactorily completed the required continuing education courses shall be deemed in compliance with this section.

(e) A manufactured home manufacturer or manufacturer is exempt from the requirements of this section. (1999-393, s. 1; 2001-421, s. 2.2; 2005-451, s. 1.)

§ 143-143.12. Bond required.

(a) A person licensed as a manufactured home salesperson shall not be required to furnish a bond, but each applicant approved by the Board for license as a manufacturer, dealer, or set-up contractor shall furnish a corporate surety bond, cash bond or fixed value equivalent in the following amounts:

- (1) For a manufacturer, two thousand dollars (\$2,000) per manufactured home manufactured in the prior license year, up to a maximum of one hundred thousand dollars (\$100,000). When no manufactured homes were produced in the prior year, the amount required shall be based on the estimated number of manufactured homes to be produced during the current year.
- (2) For a dealer who has one place of business, the amount shall be thirty-five thousand dollars (\$35,000).
- (3) For a dealer who has more than one place of business, the amount shall be twenty-five thousand dollars (\$25,000) for each additional place of business.
- (4) For a set-up contractor, the amount shall be ten thousand dollars (\$10,000).

(b) A corporate surety bond shall be approved by the Board as to form and shall be conditioned upon the obligor faithfully conforming to and abiding by the provisions of this Part. A cash bond or fixed value equivalent shall be approved by the Board as to form and terms of deposits in order to secure the ultimate beneficiaries of the bond. A corporate surety bond shall be for a one-year period, and a new bond or a proper continuation certificate shall be delivered to the Board at the beginning of each subsequent one-year period.

(c) Any buyer of a manufactured home who suffers any loss or damage by any act of a licensee that constitutes a violation of this Part may institute an action to recover against the licensee and the surety.

(d) The Board may adopt rules to assure satisfaction of claims. (1981, c. 952, s. 2; 1985, c. 487, s. 2; 1987, c. 429, s. 19; c. 827, s. 223; 1999-393, s. 1; 2000-122, s. 8; 2005-451, s. 1.)

§ 143-143.13. Grounds for denying, suspending, or revoking licenses; civil penalties.

(a) A license may be denied, suspended or revoked by the Board on any one or more of the following grounds:

- (1) Making a material misstatement in application for license.
- (2) Failing to post an adequate corporate surety bond, cash bond or fixed value equivalent. NC General Statutes - Chapter 143 Article 9A 9
- (3) Engaging in the business of manufactured home manufacturer, dealer, salesperson, or set-up contractor without first obtaining a license from the Board.
- (4) Failing to comply with the warranty service obligations and claims procedure established by this Part.
- (5) Failing to comply with the set-up requirements established by this Part.
- (6) Failing or refusing to account for or to pay over moneys or other valuables belonging to others that have come into licensee's possession arising out of the sale of manufactured homes.
- (6a) Failing to comply with the escrow or trust account provisions of Part 2 of this Article.
- (7) Using unfair methods of competition or committing unfair or deceptive acts or practices.
- (8) Failing to comply with any provision of this Part.
- (9) Failing to appear for a hearing before the Board or for a prehearing conference with a person or persons designated by the Board after proper notice or failing to comply with orders of the Board issued pursuant to this Part.
- (10) Employing unlicensed salespersons.
- (11) Offering for sale manufactured homes manufactured or assembled by unlicensed manufacturers or selling manufactured homes to unlicensed dealers for sale to buyers in this State.
- (12) Conviction of any crime listed in G.S. 143-143.10A.
- (13) Having had a license revoked, suspended or denied by the Board; or having had a license revoked, suspended or denied by a similar entity in another state; or engaging in conduct in another state which conduct, if committed in this State, would have been a violation under this Part.
- (14) Employing or contracting with any person to perform setups who is not licensed by the Board as a set-up contractor.
- (15) Failure to comply with the provisions of Chapters 47G and 47H of the General Statutes.

(b) Repealed by Session Laws 1985, c. 666, s. 38.

(c) In addition to the authority to deny, suspend, or revoke a license under this Part the Board may impose a civil penalty upon any person violating the provisions of this Part. Upon a finding by the Board of a violation of this Part, the Board shall order the payment of a penalty of not less than one hundred dollars (\$100.00) nor more than five hundred dollars (\$500.00). In determining the amount of the penalty, the Board shall consider the degree and extent of harm caused by the violation, the amount of money that inured to the benefit of the violator as a result of the violation, whether the violation was committed willfully, and the prior record of the violator in complying or failing to comply with laws, rules, or orders applicable to the violator. Each day during which a violation occurs shall constitute a separate offense. The penalty shall be payable to the Board. The Board shall remit the clear proceeds of penalties provided for in this subsection to the Civil Penalty and Forfeiture Fund in accordance with G.S. 115C-457.2.

Payment of the civil penalty under this section shall be in addition to payment of any other penalty for a violation of the criminal laws of this State. Nothing in this subsection NC General Statutes - Chapter 143 Article 9A 10 shall prevent the Board from negotiating a mutually acceptable agreement with any person as to the status of the person's license or certificate or as to any civil penalty. (1981, c. 952, s. 2; 1985, c. 487, ss. 3 to 5; c. 666, s. 38; 1985 (Reg. Sess., 1986), c. 1027, s. 51; 1987, c. 429, s. 19; 1989, c. 485, s. 45; 1991, c. 644, s. 34; 1998-215, s. 92; 1999-393, s. 1; 2003-400, s. 11; 2005-451, ss. 1, 4; 2010-164, s. 5.)

§ 143-143.14. Hearings; rules.

(a) License suspensions, revocations, and renewal refusals are subject to the provisions of Chapter 150B of the General Statutes.

(b) If the Board finds that an applicant has not met the requirements for licensure, the Board shall refuse to issue the applicant a license and shall notify the applicant in writing of the denial and the grounds for the denial. The application may also be denied for any reason for which a license may be suspended or revoked or not renewed under G.S. 143-143.13. Within 30 days after receipt of a notification that an application for a license has been

denied, the applicant may make a written request for a review by a member of the Department staff designated by the chair of the Board to determine the reasonableness of the Board's action. The review shall be completed without undue delay, and the applicant shall be notified promptly in writing as to the outcome of the review. Within 30 days after service of the notification as to the outcome, the applicant may make a written request for a hearing under Article 3A of Chapter 150B of the General Statutes if the applicant disagrees with the outcome.

(c) The Board may adopt rules for hearings and prehearing conferences under this Part, and the rules may include provisions for prefiled evidence, the use of evidence, testimony of parties, prehearing statements, prehearing conference procedures, settlement conference procedures, discovery, subpoenas, sanctions, motions, intervention, consolidation of cases, continuances, and the rights and responsibilities of parties and witnesses. (1981, c. 952, s. 2; 1987, c. 429, s. 19; 1993, c. 504, s. 34; 1993 (Reg. Sess., 1994), c. 678, s. 34; 1999-393, s. 1; 2005-451, s. 1.)

§ 143-143.15. Set-up requirements.

(a) Manufactured homes shall be set up in accordance with the standards adopted by the Commissioner.

(b) If a manufactured home is insured against damage caused by windstorm and subsequently sustains windstorm damage that indicates the manufactured home was not set up in the manner required by this section, the insurer issuing the insurance policy on the manufactured home shall not be relieved from meeting the obligations specified in the insurance policy with respect to such damage on the basis that the manufactured home was not properly set up. (1981, c. 952, s. 2; 1987, c. 429, s. 8; 1999-393, s. 1; 2005-451, s. 1.)

§ 143-143.16. Warranties.

Each manufacturer, dealer and supplier of manufactured homes shall warrant each new manufactured home sold in this State in accordance with the warranty requirements prescribed by this section for a period of at least 12 months, measured from the date of delivery of the manufactured home to the buyer. The warranty requirements for each manufacturer, dealer, supplier and set-up contractor of manufactured homes are as follows:

(1) The manufacturer warrants that all structural elements, plumbing systems, heating, cooling and fuel burning systems, electrical systems, and any other NC General Statutes - Chapter 143 Article 9A 11 components included by the manufacturer are manufactured and installed free from substantial defects.

(2) The dealer warrants:

a. That any modifications or alterations made to the manufactured home by the dealer or authorized by the dealer are free from substantial defects. Alterations or modifications made by a dealer shall relieve the manufacturer of warranty responsibility as to the item altered or modified and any resulting damage.

b. That a setup performed by the dealer on the manufactured home is performed in compliance with the Code.

c. That the setup and transportation of the manufactured home by the dealer did not result in substantial defects.

(3) The supplier warrants that any warranties generally offered in the ordinary sale of his product to consumers shall be extended to buyers of manufactured homes. The manufacturer's warranty shall remain in effect notwithstanding the existence of a supplier's warranty.

(4) The set-up contractor warrants that the manufactured home is set up in compliance with the Code and that the setup did not result in any substantial defects. (1981, c. 952, s. 2; 1987, c. 429, s. 9; 1999-393, s. 1; 2005-451, s. 1.)

§ 143-143.17. Presenting claims for warranties and substantial defects.

(a) Whenever a claim for warranty service or about a substantial defect is made to a licensee, it shall be handled as provided in this Part. The licensee shall make a record of the name and address of each claimant and the date, substance, and disposition of each claim about a substantial defect. The licensee may request that a claim be in writing, but must nevertheless record it as provided above, and may not delay service pending receipt of the written claim.

(b) When the licensee notified is not the responsible party, he shall in writing immediately notify the claimant and the responsible party of the claim. When a responsible party is asked to remedy defects, it may not fail to remedy those defects because another party may also be responsible. Nothing in this section prevents a party from obtaining compensation by way of contribution or subrogation from another responsible party in accordance with any other provision of law or contract.

(c) Within the time limits provided in this Part, the licensee shall either resolve the claim or determine that it is not justified. At any time a licensee determines that a claim for warranty service is not justified in whole or in part he shall immediately notify the claimant in writing that the claim or part of the claim is rejected and why, and shall inform the claimant that he is entitled to complain to the Board, for which a complete mailing address shall be provided. (1981, c. 952, s. 2; 1987, c. 429, s. 19; 1999-393, s. 1; 2005-451, s. 1.)

§ 143-143.18. Warranty service.

(a) When a service agreement exists between or among a manufacturer, dealer and supplier to provide warranty service, the agreement shall specify which party is to remedy warranty defects. Every service agreement shall be in writing. Nothing contained in such an agreement shall relieve the responsible party, as provided by this Part, of responsibility to perform warranty service. However, any licensee undertaking by such agreement to perform the warranty service obligations NC General Statutes - Chapter 143 Article 9A 12 of another shall thereby himself become responsible both to that other licensee and to the buyer for his failure adequately to perform as agreed.

(b) When no service agreement exists for warranty service, the responsible party as designated by this Part is responsible for remedying the warranty defect.

(c) A substantial defect shall be remedied within 45 days after the receipt of written notification from the claimant. If no written notification is given, the defect shall be remedied within 45 days after the mailing of notification by the Board, unless the claim is unreasonable or bona fide reasons exist for not remedying the defect within the 45-day period. The responsible party shall respond to the claimant in writing with a copy to the Board stating its reasons for not promptly remedying the defect and stating what further action is contemplated by the responsible party.

Notwithstanding the foregoing provisions of this subsection, defects, which constitute an imminent safety hazard to life and health shall be remedied within five working days of receipt of the written notification of the warranty claim. An imminent safety hazard to life and health shall include but not be limited to (i) inadequate heating in freezing weather; (ii) failure of sanitary facilities; (iii) electrical shock, leaking gas; or (iv) major structural failure. The Board may suspend this five-day time period in the event of widespread defects or damage resulting from adverse weather conditions or other natural catastrophes.

(d) When the person remedying the defect is not the responsible party as designated by the provisions of this Part, he shall be entitled to reasonable compensation paid to him by the responsible party. Conduct that coerces or requires a nonresponsible party to perform warranty service is a violation of this Part.

(e) Warranty service shall be performed at the site at which the manufactured home is initially delivered to the buyer, except for components which can be removed for service without substantial expense or inconvenience to the buyer.

(f) Any dealer, manufacturer or supplier may complain to the Board when warranty service obligations under this Part are not being enforced. (1981, c. 952, s. 2; 1987, c. 429, ss. 17, 19; 1999-393, s. 1; 2005-451, s. 1.)

§ 143-143.19. Dealer alterations.

(a) No alteration or modification shall be made to a manufactured home by a dealer after shipment from the manufacturer's plant, unless such alteration or modification is authorized by this Part or the manufacturer. The dealer shall ensure that all authorized alterations and modifications are performed, if so required, by qualified persons as defined in subsection (d). An unauthorized alteration or modification performed by a dealer or his agent or employee shall place primary warranty responsibility for the altered or modified item upon the dealer. If the manufacturer fulfills or is required to fulfill the warranty on the altered or modified item, he shall be entitled to recover damages in the amount of his cost and attorney's fee from the dealer.

(b) An unauthorized alteration or modification of a manufactured home by the owner or his agent shall relieve the manufacturer of responsibility to remedy defects caused by such alteration or modification. A statement to this effect, together with a warning specifying those alterations or modifications which should be performed only by qualified personnel in order to preserve warranty protection, shall be displayed clearly and conspicuously on the face of the warranty. Failure to display such statement shall result in warranty responsibility on the manufacturer.

(c) The Board is authorized to adopt rules in accordance with Chapter 150B of the General Statutes that define the alterations or modifications which must be made by qualified personnel. NC General Statutes - Chapter 143 Article 9A 13 The Board may require qualified personnel only for those alterations and modifications which could substantially impair the structural integrity or safety of the manufactured home.

(d) In order to be designated as a person qualified to alter or modify a manufactured home, a person must comply with State licensing or competency requirements in skills relevant to performing alterations or modifications on manufactured homes. (1981, c. 952, s. 2; 1987, c. 429, s. 19; c. 827, s. 1; 1999-393, s. 1; 2005-451, s. 1.)

§ 143-143.20. Disclosure of manner used in determining length of manufactured homes.

In any advertisement or other communication regarding the length of a manufactured home, a manufacturer or dealer shall not include the coupling mechanism in describing the length of the home. (1981, c. 952, s. 2; 2005-451, s. 1.)

§ 143-143.20A. Display of pricing on manufactured homes.

- (a) If the manufacturer of a manufactured home publishes a manufacturer's suggested retail price, that price shall be displayed near the front entrance of the manufactured home.
- (b) Each manufactured home dealer shall prominently display a sign and provide to each buyer a notice, developed by the North Carolina Manufactured Housing Board, containing information about the Board, including how to file a consumer complaint with the Board and the warranties and protections provided for each new manufactured home under federal and State law. (2003-400, s. 6; 2005-451, s. 1.)

§ 143-143.21: Repealed by Session Laws 1993, c. 409, s. 6.

§ 143-143.21A. Purchase agreements; buyer cancellations.

- (a) A purchase agreement for a manufactured home shall include all of the following:
 - (1) A description of the manufactured home and all accessories included in the purchase.
 - (2) The purchase price for the home and all accessories.
 - (3) The amount of deposit or other payment toward or payment of the purchase price of the manufactured home and accessories that is made by the buyer.
 - (4) The date the retail purchase agreement is signed.
 - (5) The estimated terms of financing the purchase, if any, including the estimated interest rate, number of years financed, and monthly payment.
 - (6) The buyer's signature.
 - (7) The dealer's signature.
- (b) The purchase agreement shall contain, in immediate proximity to the space reserved for the signature of the buyer and in at least ten point, all upper-case Gothic type, the following statement:

"I UNDERSTAND THAT I HAVE THE RIGHT TO CANCEL THIS PURCHASE BEFORE MIDNIGHT OF THE THIRD BUSINESS DAY AFTER THE DATE THAT I HAVE SIGNED THIS AGREEMENT. I UNDERSTAND THAT THIS CANCELLATION MUST BE IN WRITING. IF I CANCEL THE PURCHASE AFTER THE THREE-DAY PERIOD, I UNDERSTAND THAT THE DEALER MAY NOT HAVE ANY OBLIGATION TO GIVE ME BACK ALL OF THE MONEY THAT I PAID THE DEALER. I UNDERSTAND ANY CHANGE TO THE TERMS OF THE PURCHASE AGREEMENT BY THE DEALER WILL CANCEL THIS AGREEMENT." NC General Statutes - Chapter 143 Article 9A 14
- (c) At the time the deposit or other payment toward or payment for the purchase price is received by the dealer, the dealer shall give the buyer a copy of the purchase agreement and a completed form in duplicate, captioned "Notice of Cancellation," which shall be attached to the purchase agreement, be easily detachable, and explain the buyer's right to cancel the purchase and how that right can be exercised.
- (d) The dealer shall return the deposit or other payment toward or payment for the purchase price to the buyer if the buyer cancels the purchase before midnight of the third business day after the date the buyer signed the purchase agreement or if any of the material terms of the purchase agreement are changed by the dealer. To make the cancellation effective, the buyer shall give the dealer written notice of the buyer's cancellation of the purchase. The dealer shall return the deposit or other payment toward or payment for the purchase price to the buyer within seven business days, or 15 business days when payment is by personal check, after receipt of the notice of cancellation or within three business days of any change by the dealer of the purchase agreement. For purposes of this section, "business day" means any day except Sunday and legal holidays. Each time the dealer gives the buyer a new set of financing terms, unless the financing terms are more favorable to the buyer, the buyer shall be given another three-

day cancellation period. The dealer shall not commence setup procedures until after the final three-day cancellation period has expired.

(e) If the buyer cancels the purchase after the three-day cancellation period, but before the sale is completed, and if:

(1) The manufactured home is in the dealer's inventory, the dealer may retain from the deposit or other payment received from the buyer actual damages up to a maximum of ten percent (10%) of the purchase price; or

(2) The manufactured home is specially ordered from the manufacturer for the buyer, the dealer may retain actual damages up to the full amount of the buyer's deposit or other payment received from the buyer.

(f) Repealed by Session Laws 2005-451, s. 5, effective April 1, 2006. (1993, c. 409, s. 7; 1999-393, s. 1; 2003-400, s. 7; 2005-451, ss. 1, 5; 2006-259, s. 24.5.)

§ 143-143.21B. Dealer cancellation; deposit refund.

A dealer shall refund to a buyer the full amount of a deposit on the purchase of a manufactured home if the buyer has fulfilled his obligations under the purchase agreement and the dealer cancels the purchase at any time. (1998-211, s. 37; 2005-451, s. 1.)

§ 143-143.22. Inspection of service records.

The Board may inspect the service records of a manufacturer, dealer, supplier or set-up contractor relating to a written warranty claim or complaint made to the Board against the manufacturer, dealer, supplier, or set-up contractor. Every licensee shall send to the Board upon request within 10 days a copy of every document or record pertinent to any complaint or claim for service. (1981, c. 952, s. 2; 1999-393, s. 1; 2005-451, s. 1.)

§ 143-143.23. Other remedies not excluded.

Nothing in this Part, rules adopted by the Board, or any action of the Board shall limit any right or remedy available to the buyer or any power or duty of the Attorney General. (1981, c. 952, s. 2; 1987, c. 429, s. 19; 1999-393, s. 1; 2005-451, s. 1.)

§ 143-143.24. Engaging in business without license a Class 1 misdemeanor. NC General Statutes - Chapter 143 Article 9A 15 If any person shall unlawfully act as a manufactured home manufacturer, dealer, salesperson, or set-up contractor without first obtaining a license from the Board, as provided in this Part, he shall be guilty of a Class 1 misdemeanor. (1985, c. 487, s. 6; 1987, c. 429, s. 19; 1993, c. 539, s. 1010; 1994, Ex. Sess., c. 24, s. 14(c); 1999-393, s. 1; 2005-451, s. 1.)

§ 143-143.25. Staff support for Board.

The Manufactured Building Division of the Department shall provide clerical and other staff services required by the Board; and shall administer and enforce all provisions of this Part and all rules adopted under this Part, subject to the direction of the Board; except for powers and duties delegated by this Part to local units of government, other State agencies, or to any persons. (1991, c. 644, s. 36; 1999-393, s. 1; 2005-451, s. 1.)

§§ 143-143.26 through 143-143.49: Reserved for future codification purposes.

Part 2. Buyer Deposit, Escrow or Trust Accounts.

§ 143-143.50. Escrow or trust account required.

(a) Dealers shall maintain buyers' deposits in an escrow or trust account with a bank. A dealer shall not commingle any other funds with buyers' deposits in the escrow or trust account.

(b) Dealers shall notify the Board in writing when the escrow or trust account is established. The notification shall include the name and number of the account and the name and location of the bank holding the account.

(c) All buyer funds shall be placed in the escrow or trust account no later than the close of the third banking business day after receipt.

(d) Dealers shall provide buyers with a receipt for all buyer deposits received by the dealer. The receipt shall include the amount of the buyer deposit, the date the deposit was provided to the dealer, and the name and address of the bank where the buyer's funds will be deposited. (2005-451, s. 6.)

§ 143-143.51. Use of escrow or trust funds; penalty for violations.

(a) Buyer funds in the dealer's escrow or trust account shall be held for the benefit of the buyer and may only be used for purposes authorized under the contractual obligations of the dealer to the buyer. No buyer funds in the dealer's escrow or trust account may be used by the dealer until after all the terms set forth in G.S. 143-143.21A are finalized and after the three-day right of cancellation period as set forth in G.S. 143-143.21A has expired. The dealer may use buyer funds to complete the steps necessary for site preparation of property, when approved in writing in advance by the buyer. Buyer funds in the dealer's escrow or trust account shall be promptly returned to the buyers when the buyer is entitled to return of the funds in accordance with G.S. 143-143.21A.

(b) Notwithstanding any other provision of law and in addition to any other sanction the Board may impose under this Article, if the Board finds that a dealer has used a buyer's funds for a purpose that is not authorized under subsection (a) of this section or if the Board finds that a dealer has failed to place deposits in the dealer's escrow or trust account, the Board may fine the dealer or order restitution to the buyer in an amount up to the amount that the dealer misappropriated or failed to place in the account. (2005-451, s. 6.) NC General Statutes - Chapter 143 Article 9A 16

§ 143-143.52. Minimum requirements for dealer records for escrow or trust accounts at banks.

The records required for escrow or trust accounts maintained at a bank shall consist of the following and be maintained for a period of five years from the date of purchase:

(1) All bank receipts or deposit slips listing the source and date of receipt of all funds deposited in the account and the name of the buyer to whom the funds belong.

(2) All cancelled checks or other instruments drawn on the account, or printed digital images thereof furnished by the bank, showing the amount, date, and recipient of the disbursement.

(3) All instructions or authorizations to transfer, disburse, or withdraw funds from the escrow or trust account.

(4) All bank statements and other documents received from the bank with respect to the escrow or trust account, including notices of return or dishonor of any instrument drawn on the account against insufficient funds.

(5) A ledger containing a record of receipts and disbursements for each buyer from whom and for whom funds are received and showing the current balance of funds held in the escrow or trust account for each buyer. (2005-451, s. 6.)

§ 143-143.53. Accountings for escrow or trust funds.

Upon the request of the buyer, the dealer shall provide to the buyer a written accounting of the receipts and disbursements of all escrow or trust funds upon the complete disbursement of the escrow or trust accounts. (2005-451, s. 6.)

§ 143-143.54. Audits and record inspection.

All financial records required by this Part shall be subject to audit for cause and to random audit at the discretion of and by the Board, the Commissioner, or the Attorney General. The Board may inspect these records periodically, without prior notice and may also inspect these records whenever the Board determines that the records are pertinent to an investigation of any complaint against a licensee. The dealer shall provide written authorization to the bank that holds the escrow or trust account to release any and all requested information relative to the account to the parties authorized under this section to inspect those records. (2005-451, s. 6.)

NC General Statutes - Chapter 143 Article 9B

Article 9B.

Uniform Standards Code for Manufactured Homes.

§ 143-144. Short title.

This Article shall be known and may be cited as "The Uniform Standards for Manufactured Homes Act." (1969, c. 961, s. 1; 1985, c. 487, s. 7; 1987, c. 429, s. 19; 1999-393, s. 2.)

§ 143-145. Definitions.

The following definitions apply in this Article:

(1) Act. – The National Manufactured Housing Construction and Safety Standards Act of 1974, 42 U.S.C. § 5401, et seq., federal regulations adopted under the Act, and any laws enacted by the United States Congress that supersede or supplement the Act.

(2) Commissioner. – The Commissioner of Insurance of the State of North Carolina or an authorized designee of the Commissioner.

(3) Repealed by Session Laws 1999-393, s. 2.

(4) HUD. – The United States Department of Housing and Urban Development or any successor agency.

(5) Inspection department. – A North Carolina city or county building inspection department authorized by Chapter 160A or Chapter 153A of the General Statutes.

(6) Label. – The form of certification required by HUD to be permanently affixed to each transportable section of each manufactured home manufactured for sale to a purchaser in the United States to indicate that the manufactured home conforms to all applicable federal construction and safety standards.

(7) Manufactured home. – A structure, transportable in one or more sections, which in the traveling mode is eight body feet or more in width, or 40 body feet or more in length, or, when erected on site, is 320 or more square feet; and which is built on a permanent chassis and designed to be used as a dwelling, with or without permanent foundation when connected to the required utilities, including the plumbing, heating, air conditioning and electrical systems contained therein. "Manufactured home" includes any structure that meets all of the requirements of this subsection except the size requirements and with respect to which the manufacturer voluntarily files a certification required by the Secretary of HUD and complies with the standards established under the Act.

For manufactured homes built before June 15, 1976, "manufactured home" means a portable manufactured housing unit designed for transportation on its own chassis and placement on a temporary or semipermanent foundation having a measurement of over 32 feet in length and over eight feet in width. "Manufactured home" also means a double-wide manufactured home, which is two or more portable manufactured housing units designed for transportation on their own chassis that connect on site for placement on a temporary or semipermanent foundation having a measurement of over 32 feet in length and over eight feet in width. NC General Statutes - Chapter 143 Article 9B 2

(8) Repealed by Session Laws 1999-393, s. 2. (1969, c. 961, s. 2; 1971, c. 1172, s. 1; 1985, c. 487, s. 7; 1987, c. 429, ss. 10, 19; 1999-393, s. 2.)

§ 143-146. Statement of policy; rule-making power.

(a) Manufactured homes, because of the manner of their construction, assembly and use and that of their systems, components and appliances (including heating, plumbing and electrical systems) like other finished products having concealed vital parts may present hazards to the health, life and safety of persons and to the safety of property unless properly manufactured. In the sale of manufactured homes, there is also the possibility of defects not readily ascertainable when inspected by purchasers. It is the policy and purpose of this State to provide protection to the public against those possible hazards, and for that purpose to forbid the manufacture and sale of new manufactured homes, which are not so constructed as to provide reasonable safety and protection to their owners and users. This Article provides to the Commissioner all necessary authority to enable the State to obtain approval as a State Administrative Agency under the provisions of the Act.

(b) through (d) Repealed by Session Laws 1999-393, s. 2.

(e) The Commissioner may adopt rules to carry out the provisions of the Act and this Article, including rules for consumer complaint procedures and rules for the enforcement of the standards and regulations established and adopted by HUD under the Act. (1969, c. 961, s. 3; 1971, c. 1172, s. 2; 1979, c. 558, ss. 5, 6; 1985, c. 487, s. 7; 1987, c. 429, ss. 11, 12, 18, 19; 1999-393, s. 2.)

§ 143-147. Structures built under previous standards.

The legal status of any structure built before the effective date of the Act shall not be affected by any changes made in this Article by the General Assembly. (1969, c. 961, s. 4; 1971, c. 1172, s. 3; 1985, c. 487, s. 7; 1987, c. 429, s. 19; 1999-393, s. 2.)

§ 143-148. Certain structures excluded from coverage.

The Commissioner may by rule provide for the exclusion of certain structures by certification in accordance with the Act. (1969, c. 961, s. 5; 1971, c. 1172, s. 4; 1979, c. 558, s. 3; 1987, c. 429, s. 13; 1999-393, s. 2.)

§ 143-149. Necessity for obtaining label for purposes of sale.

No person shall sell or offer for sale any manufactured home in this State that does not have a label. It is a defense to any prosecution for a violation of this section if a person shows that a certificate of title for the manufactured home as required by G.S. 20-52 was obtained before June 15, 1976, or produces other satisfactory evidence on file with the North Carolina Division of Motor Vehicles that the manufactured home was manufactured before June 15, 1976. (1971, c. 1172, s. 5; 1985, c. 487, s. 7; 1999-393, s. 2.)

§ 143-150. No electricity to be furnished units not in compliance.

It is unlawful for any person to furnish electricity for use in any manufactured home without first ascertaining that the manufactured home and its electrical supply has been inspected pursuant NC General Statutes - Chapter 143 Article 9B 3 to G.S. 143-139 by the inspection authority having jurisdiction and found to comply with the requirements of the State Electrical Code. The certificate of compliance issued by the inspection jurisdiction shall be accepted as evidence of compliance. (1971, c. 1172, s. 6; 1985, c. 487, s. 7; 1993, c. 504, s. 35; 1999-393, s. 2.)

§ 143-151. Penalties.

(a) Any person who is found by the Commissioner to have violated the provisions of the Act, this Article, or any rules adopted under this Article, shall be liable for a civil penalty not to exceed one thousand dollars (\$1,000) for each violation. Each violation shall constitute a separate violation for each manufactured home or for each failure or refusal to allow or perform an act required by the Act, this Article, or any rules adopted under this Article. The maximum civil penalty may not exceed one million dollars (\$1,000,000) for any related series of violations occurring within one year after the date of the first violation. In determining the amount of the penalty, the Commissioner shall consider the degree and extent of harm caused by the violation, the amount of money that inured to the benefit of the violator as a result of the violation, whether the violation was willful, and the prior record of the violator in complying or failing to comply with laws, rules, or orders applicable to the violator. The clear proceeds of civil penalties provided for in this section shall be remitted to the Civil Penalty and Forfeiture Fund in accordance with G.S. 115C-457.2.

(b) Any individual, or a director, officer (or agent of a corporation who knowingly and willfully violates the Act, this Article, or any rules adopted under this Article in a manner that threatens the health or safety of any purchaser is guilty of a Class I felony. (1971, c. 1172, s. 7; 1979, c. 558, s. 1; 1985, c. 487, s. 7; 1987, c. 429, s. 19; 1993, c. 539, s. 1011; 1994, Ex. Sess., c. 24, s. 14(c); 1998-215, s. 93; 1999-393, s. 2.)

§ 143-151.1. Enforcement.

The Commissioner may initiate any appropriate action or proceeding to prevent, restrain, or correct any violation of the Act, this Article, or any rules adopted under this Article. The Commissioner, or any of his deputies or employees, upon showing proper credentials and in the discharge of their duties under this Article, or the Act, is authorized at reasonable hours and without advance notice to enter and inspect all factories, warehouses, or establishments in this State in which manufactured homes are manufactured, stored or held for sale. (1971, c. 1172, s. 8; 1979, c. 558, s. 2; 1985, c. 487, s. 7; 1987, c. 429, ss. 15, 18, 19; 1999-393, s. 2.)

§ 143-151.2. Fees.

(a) The Commissioner shall establish a monitoring inspection fee in an amount required by the Secretary of HUD. This monitoring inspection fee shall be an amount paid by each manufactured home manufacturer in this State for each manufactured home produced by the manufacturer in this State.

(b) The monitoring inspection fee shall be paid by the manufacturer to the Secretary of HUD or the Secretary's agent. (1979, c. 558, s. 4; 1985, c. 487, s. 7; 1987, c. 429, s. 18; 1999-393, s. 2.)

§ 143-151.3. Reports. NC General Statutes - Chapter 143 Article 9B 4

Each manufacturer, distributor, and dealer of manufactured homes shall establish and maintain such records, make such reports, and provide such information as the Commissioner or the Secretary of HUD may reasonably require to be able to determine whether the manufacturer, distributor, or dealer has acted or is acting in compliance with this Article, or the Act and shall, upon request of a person designated by the Commissioner or the Secretary of HUD, permit the person to inspect appropriate books, papers, records and documents relevant to determining whether the manufacturer, distributor, or dealer has acted or is acting in compliance with this Article or the Act, and any rules adopted by the Commissioner under this Article. (1979, c. 558, s. 4; 1985, c. 487, s. 7; 1987, c. 429, ss. 18, 19; 1999-393, s. 2.)

§ 143-151.4. Notification of defects and correction procedures.

Every manufacturer of manufactured homes shall provide for notification and correction procedures in any manufactured home produced by the manufacturer in accordance with the Act, this Article, and any rules adopted by the Commissioner. (1979, c. 558, s. 4; 1985, c. 487, s. 7; 1987, c. 429, s. 14; 1999-393, s. 2.)

§ 143-151.5. Prohibited acts.

(a) No person shall:

(1) Manufacture for sale, lease, sell, offer for sale or lease, or introduce or deliver, or import into the United States, any manufactured home that is manufactured on or after the effective date of any applicable manufactured home construction and safety standard under the Act or this Article and that does not comply with the standard, except as provided in subsections (b), (c), and (d) of this section.

(2) Fail or refuse to permit access to or copying of records, or fail to make reports or provide information, or fail or refuse to permit entry or inspection, as required under the Act or this Article.

(3) Fail to furnish notification of any defect as required by the Act or this Article.

(4) Fail to issue a label or issue a label if the person in the exercise of due care has reason to know that the label is false or misleading in a material respect.

(5) Fail to comply with a rule adopted or an order issued by the Commissioner under this Article.

(6) Issue a certification pursuant to G.S. 143-148 if the person in the exercise of due care has reason to know that the certification is false or misleading in a material respect.

(b) (1) Subdivision (a)(1) of this section does not apply to the sale, the offer for sale, or the introduction or delivery of any manufactured home after the first purchase of it in good faith for purposes other than resale.

(2) Subdivision (a)(1) of this section does not apply to any person who establishes that he did not have reason to know in the exercise of due care that the manufactured home was not in conformity with applicable manufactured home construction and safety standards.

(c) Subdivision (a)(1) of this section shall not apply to any person who, before the first purchase, holds a certificate of compliance issued by the manufacturer or importer of the manufactured home to the effect that the manufactured home conforms to all applicable manufactured home construction and safety standards, unless the person knows that the NC General Statutes - Chapter 143 Article 9B 5 manufactured home does not so conform. (1979, c. 558, s. 4; 1985, c. 487, s. 7; 1987, c. 429, ss. 16, 19; 1999-393, s. 2.)

§ 143-151.6. Reserved for future codification purposes.

§ 143-151.7. Reserved for future codification purposes.

APPENDIX K

APA Rules

NORTH CAROLINA ADMINISTRATIVE CODE

SECTION .0900 - MANUFACTURED HOUSING BOARD 11 NCAC 08 .0901 MANUFACTURED HOUSING BOARD

The North Carolina Manufactured Housing Board is established to provide for a comprehensive framework for regulation of all segments of the manufactured housing industry. The Commissioner of Insurance or his designee shall serve as chairman of a nine member board representing the industry and the public.

History Note: Authority G.S. 143-143.8; 143-143.10;

Eff. January 1, 1983;

Amended Eff. April 1, 1989;

Pursuant to G.S. 150B-21.3A, rule is necessary without substantive public interest Eff. January 9, 2018.

11 NCAC 08 .0902 ADDRESS

The mailing address for the North Carolina Manufactured Housing Board is: North Carolina Manufactured Housing Board, c/o North Carolina Department of Insurance, 1202 Mail Service Center, Raleigh, NC 27699-1202.

History Note: Authority G.S. 143-143.8; 143-143.10; 143-143.17;

Eff. January 1, 1983;

Amended Eff. June 1, 2005; April 1, 1989;

Pursuant to G.S. 150B-21.3A, rule is necessary without substantive public interest Eff. January 9, 2018.

11 NCAC 08 .0903 RULE-MAKING AND HEARING PROCEDURES

Copies of Standards and rules adopted by the Manufactured Housing Board or the Commissioner of Insurance may be obtained by writing or calling:

North Carolina Manufactured Housing Board

Manufactured Building Division

1202 Mail Service Center

Raleigh, North Carolina 27699-1202

Phone (919) 647-0000

The Manufactured Building Division is located at:

325 North Salisbury Street

Raleigh, North Carolina 27603.

History Note: Legislative Objection Lodged Eff. December 22, 1982;

Authority G.S. 143-143.10; 143-143.11; 143-143.11B; 143-143.12; 143-143.14; 143-143.19;

Eff. January 1, 1983;

Amended Eff. March 1, 1988 at ARRC request to cure referenced Legislative Objection;

Amended Eff. January 1, 2018; June 1, 2005;

Pursuant to G.S. 150B-21.3A, rule is necessary without substantive public interest Eff. January 9, 2018.

11 NCAC 08 .0904 FORMS

(a) An application for a license as a manufactured housing manufacturer or manufactured housing dealer shall include the following:

(1) the name of the person or business applicant;

(2) the business address of the applicant;

(3) the state under whose laws the applicant firm or corporation is organized or incorporated;

(4) a resume of each owner, partner, and officer of the applicant firm or corporation. Each resume shall state his or her education and a complete job history, as well as a listing of residences for the last seven years;

(5) the type of license applied for;

(6) a signature of the person with authority to legally obligate the applicant; and

- (7) a statement that the appropriate bond is attached.
- (b) An application for a license as a manufactured set-up contractor shall include the following:
 - (1) the name of the person or business applicant;
 - (2) the business address of the applicant;
 - (3) the state under whose laws the applicant firm or corporation is organized or incorporated;
 - (4) a resume of each owner, partner, or officer of the applicant firm or corporation. Each resume shall state his or her education and a complete job history, as well as a listing of residences for the last seven years;
 - (5) the type of license applied for;
 - (6) a signature of the person with authority to legally obligate the applicant;
 - (7) a statement that the appropriate bond is attached;
 - (8) a criminal history record check consent form signed by each owner, partner, and officer of the applicant firm or corporation with their initial application and other documentation or materials required by G.S. 143-143.10A; and
 - (9) the social security number for each owner.
- (c) An application for a license as a manufactured housing salesperson shall include the following:
 - (1) the name of the applicant;
 - (2) the applicant's address;
 - (3) the name and business address of the dealer employing the applicant;
 - (4) the name and address of previous employers of the applicant for the past three years;
 - (5) three personal references;
 - (6) a wallet size photograph;
 - (7) a criminal history record check consent form signed by each applicant with their initial application and other documentation or materials required by G.S. 143-143.10A; and
 - (8) The applicant's social security number.
- (d) Corporate surety bonds, as specified in 11 NCAC 08 .0905, shall include the name of the applicant, the name of the surety, the amount of the bond, and the terms of cancellation.
- (e) The Board shall provide applications for renewal of licenses, which shall include the name and address of the applicant, the type of license, the date the license expires, the amount of the license renewal fee, and instructions for completion.
- (f) A request for cancellation of license shall include the name and address of the licensee, the effective date of the cancellation, the specific reason for the cancellation, and the signature of the person with authority to legally obligate the licensee.
- (g) All applications pursuant to this Rule shall use a form provided by the Manufactured Housing Board. Each application and form required by this Rule may be obtained from the North Carolina Manufactured Housing Board, c/o North Carolina Department of Insurance, Manufactured Building Division, 1202 Mail Service Center, Raleigh, NC 27699-1202.

History Note: Authority G.S. 110-142.1; 132-1.10; 143-143.10; 143-143.10A; 143-143.11; 143-143.12; Eff. January 1, 1983;

Amended Eff. July 1, 2017; February 1, 2006; March 1, 1988;

Pursuant to G.S. 150B-21.3A, rule is necessary without substantive public interest Eff. January 9, 2018.

11 NCAC 08 .0905 LICENSING

- (a) Any person employed by a dealer whose occupational activity is that of selling on behalf of the retail dealership shall be licensed as a salesperson. Each salesperson's license shall be conspicuously displayed at all times by the dealership employing the salesperson.
- (b) The following shall not be required to be licensed as a manufactured housing dealer:
 - (1) Receivers, trustees, administrators, executors, guardians or other persons appointed by or acting under the judgment or order of any court;
 - (2) Public officials while performing their official duties;
 - (3) Persons disposing of manufactured homes acquired for their own use, provided that said home is not used for the purpose of avoiding the provisions of G.S. 143-143.11;
 - (4) Licensed real estate salesmen or brokers who negotiate or sell a manufactured home for any individual who is the owner of not more than three manufactured homes;

- (5) Banks and finance companies who sell repossessed manufactured homes who do not maintain a sales lot or building with one or more employed retail salespersons.
- (c) Licenses shall be issued by the Board whenever the application is in compliance with the applicable laws and regulations. Such license shall entitle the licensee to conduct the specified business for a period of one year from date of issuance or the first day of July, whichever is earlier. The Board may, if it deems necessary, cause an investigation to be made to ascertain if all the requirements set forth in the application are true and shall not issue a license to the applicant until it is satisfied as to the accuracy of the application.
- (d) Manufactured housing manufacturers, dealers, and set-up contractors shall conspicuously display their licenses at all times at their place of business.
- (e) Whenever a bond is required by G.S. 143-143.12, before any license shall be issued by the Board, the applicant shall deliver to the Board a corporate surety bond, cash bond or fixed value equivalent. The bond shall be to the Board and in favor of any person who shall suffer any loss as a result of any violation of the law or administrative rules governing manufactured housing. The bond shall be for the license period and a new bond or proper continuation certificate shall be delivered to the Board at the beginning of each license period. The bond for one type of license may not be considered as the bond for another type of license.
- (f) License fees are as follows:
- (1) three hundred dollars (\$300.00) per Certificate of Origin plant for manufactured housing manufacturers;
 - (2) two hundred fifty dollars (\$250.00) per county of operation for manufactured housing dealers;
 - (3) one hundred dollars (\$100.00) per county for supplemental manufactured housing dealer locations;
 - (4) twenty-five dollars (\$25.00) for retail manufactured housing salesperson; and
 - (5) two hundred fifty dollars (\$250.00) per business location for set-up contractors.

History Note: Authority G.S. 143-143.10; 143-143.11;

*Legislative Objection Lodged Eff. December 22, 1982;
Eff. January 1, 1983;*

Amended Eff. January 4, 1994; June 1, 1990; April 1, 1990; April 1, 1989;

Pursuant to G.S. 150B-21.3A, rule is necessary without substantive public interest Eff. January 9, 2018.

11 NCAC 08 .0906 DUTIES AND RESPONSIBILITIES OF BOARD

- (a) The Board shall be required to keep minutes and records of all its transactions, proceedings and meetings, and duly certified copies thereof shall be sufficient to comply with the rules of evidence.
- (b) The Board may investigate on its own initiative or upon receipt of inquiries or complaints (See 11 NCAC 8 .0910) any allegation of a wrongful act or acts involving manufactured housing manufacturers, suppliers, dealers, salesmen, or set-up contractors. Violation of the laws or administrative rules governing the manufactured housing industry shall be grounds for revocation or suspension of licenses issued by the Board or for the civil penalties prescribed by G.S. 143-143.13.

History Note: Authority G.S. 143-143.10; 143-143.13; 143-143.14; 143-143.17; 143-143.18; 143-143.22;

*Legislative Objection Lodged Eff. December 22, 1982;
Eff. January 1, 1983;*

Amended Eff. March 1, 1988 at ARRC request to cure referenced Legislative Objection;

Pursuant to G.S. 150B-21.3A, rule is necessary without substantive public interest Eff. January 9, 2018.

11 NCAC 08 .0907 UNFAIR COMPETITION AND DECEPTIVE PRACTICES

Unfair methods of competition or unfair or deceptive commercial acts or practices shall include, but not be limited to:

- (1) Failure to perform repairs, alterations and/or additions completely or in a workmanlike and competent manner.
- (2) Repeated failure to give timely notice of inability to appear for a scheduled repair.
- (3) Representing used manufactured homes, appliances, or fixtures as new or failure to identify used appliances, fixtures and/or equipment in new manufactured homes.
- (4) Repeated failure to respond promptly to consumer complaints and inquiries.
- (5) Failure to give clear and conspicuous notice that the wheels, axles, and/or tongue are not included in the sales price, when such is the case. An example of clear and conspicuous notice is a sticker or printed notice in bold face type stating "The purchase price does not include the wheels, axles, and tongue of this manufactured home."

(6) Failure to give clear and conspicuous notice of the significance of leveling a manufactured home and when releveling becomes the customer's responsibility. An example of clear and conspicuous notice is a sticker or printed notice in bold face type stating "Proper set-up, leveling and anchoring of your manufactured home is necessary in order to assure proper functioning and safe operation of your manufactured home."

(7) Misrepresenting the model year or size of a manufactured home. Size shall be calculated as follows:

(a) length means the distance from the exterior of the front wall (nearest to the drawbar and coupling mechanism) to the exterior of the rear wall (at the opposite end of the home) where such walls enclose living or other interior space, but not bay windows, porches, drawbars, couplings, hitches, wall and roof extensions, or other attachments;

(b) width means the distance from the exterior of one side wall to the exterior of the opposite side wall where such walls enclose living or other interior space, but not bay windows, porches, wall and roof extensions, or other attachments;

(c) measurements may be represented to the nearest foot.

History Note: Authority G.S. 143-143.10; 143-143.13;

Legislative Objection Lodged Eff. December 22, 1982;

Eff. January 1, 1983;

Amended Eff. March 1, 1988 at ARRC request to cure referenced Legislative Objection;

Pursuant to G.S. 150B-21.3A, rule is necessary without substantive public interest Eff. January 9, 2018.

11 NCAC 08 .0908 SUSPENSION OF IMMINENT SAFETY HAZARD PERIOD

(a) Suspension of the five day period to remedy imminent safety hazards in the event of widespread defects or damages resulting from adverse weather conditions or other natural catastrophes authorized by G.S. 143-143.18 may be ordered by the Board in emergency meeting or telephone conference by a quorum of the Board.

(b) Such suspension order shall be in writing and shall specify an expiration date for the suspension.

History Note: Authority G.S. 143-143.18;

Eff. January 1, 1983;

Pursuant to G.S. 150B-21.3A, rule is necessary without substantive public interest Eff. January 9, 2018.

11 NCAC 08 .0909 MAINTENANCE OF RECORDS

(a) Every manufactured housing manufacturer, supplier, dealer, and set-up contractor shall maintain for at least five years all service records.

(b) Every manufactured housing manufacturer, supplier, dealer, or set-up contractor shall maintain a record of all written complaints listing the name and address of the complainant, the nature of the complaint, and the disposition of the complaint. This record shall be retained for at least five years.

(c) Nothing in this Rule shall be construed to prohibit use of electronic or photographic processes to store such records.

History Note: Authority G.S. 143-143.10 through 143-143.13; 143-143.17; 143-143.18; 143-143.22;

Eff. January 1, 1983;

Pursuant to G.S. 150B-21.3A, rule is necessary without substantive public interest Eff. January 9, 2018.

11 NCAC 08 .0910 COMPLAINT HANDLING AND INSPECTION PROCEDURE

(a) Complaints received by telephone shall be confirmed in writing over the signature of the owner or his or her agent; however, this shall not delay any action to resolve the complaint. Complaints shall be processed as follows:

(1) The Manufactured Building Division shall forward complaints to the manufactured housing manufacturer, dealer, or set-up contractor as appropriate.

(2) If the complaint is not resolved, the Manufactured Building Division shall schedule an on-site inspection or the deputy commissioner shall arrange a conference to discuss the problem. Unless otherwise agreed, concerned parties shall be given at least 72 hours notice, orally, in writing, or electronically, of the time and place of the inspection or conference and the opportunity to attend the inspection or conference.

(3) If the complaint is not resolved, the deputy commissioner shall refer the complaint to the Board. The secretary of the Board may recommend legal action be taken to ensure compliance with the applicable statutes and rules. Such action may include the convening of a public hearing.

(b) The Manufactured Building Division shall not knowingly attempt to resolve a complaint which is also the subject matter of a pending lawsuit filed by the complainant or on the complainant's behalf by the complainant's attorney

unless authorized by the Board, which authorization shall occur upon mutual assent of all parties to the lawsuit, whether through the parties themselves or attorneys for the parties. If no lawsuit has been filed but the complainant has retained an attorney, the Manufactured Building Division shall, upon request by the complainant or the complainant's attorney, investigate a complaint, which investigation shall consist of inspecting the home for violations of the Code, as defined in G.S. 143-143.9, providing a copy of the inspection report to all the parties, and attempting to resolve the matter between the parties.

History Note: Authority G.S. 143-143.10; 143-143.13; 143-143.14; 143-143.17;

Eff. January 1, 1983;

Amended Eff. June 1, 2005;

Pursuant to G.S. 150B-21.3A, rule is necessary without substantive public interest Eff. January 9, 2018.

11 NCAC 08 .0911 SALESMAN EXAM; TEMPORARY LICENSE; LICENSE TRANSFER; FEES

(a) A salesman's license shall be issued to any applicant after the Board has approved the applicant's criminal history record check upon receipt by the Board of a properly executed application, receipt of the applicant of a passing grade (70 percent of a possible 100 percent) on a written examination administered by the Board, and qualification of the applicant for licensure, except as follows:

(1) Those persons holding a Registered Housing Specialist certification from the North Carolina Manufactured Housing Institute on or before June 30, 1992, are exempt from the examination requirement.

(2) Any salesman who has been tested and licensed under this Section and whose license has lapsed is not required to be re-tested if he re-applies for licensing within 12 months after the expiration of the lapsed license.

(b) A temporary salesman's license shall be issued prior to the Board's approval of the applicant's criminal history record check for a period of 90 days to a person upon request of the employing dealer. The holder of a valid salesman's or temporary salesman's license may sell manufactured homes only for the dealer with whom he is employed as shown on the application. A temporary salesman's license shall not be renewed.

(c) A salesman's license is valid only as long as the person remains employed with the dealer shown on the application. A salesman must apply for a new salesman's license if he changes or transfers from one dealer to another. In lieu of applying for a new license, the salesman may transfer his license from one dealership to another upon application from the new dealer and the salesman and approval of the Board. When a salesman leaves employment with a dealer, the dealer shall report this fact to the Board within 10 days thereafter.

(d) The fee for a salesman's or temporary salesman's license shall be twenty five dollars (\$25.00). The temporary salesman's license fee shall apply toward the salesman's license fee if both licenses are issued in the same license year. The fee for a salesman's license transfer application shall be fifteen dollars (\$15.00).

(e) A criminal history record check fee in the amount of fifty five dollars (\$55.00) shall be submitted with each applicant application.

History Note: Authority G.S. 143-143.10; 143-143.10A; 143-143.11;

Eff. July 1, 1992;

Amended Eff. February 1, 2006;

Pursuant to G.S. 150B-21.3A, rule is necessary without substantive public interest Eff. January 9, 2018.

11 NCAC 08 .0912 SET-UP CONTRACTOR EXAMS

(a) Definitions. The definitions contained in G.S. 143-143.9 are incorporated into this Rule by reference. As used in this Rule, "qualifier" means an individual taking the examination on behalf of an applicant that is not an individual.

(b) Examination Required. Each applicant for a set-up contractor's license shall pass a written examination administered by the Board before the Board will issue a license to the applicant. Every applicant shall pass the examination with a grade of at least 70 percent. An applicant who does not pass the examination shall be allowed to retake the examination.

(c) Time and Place of Examinations. The Board shall administer examinations in its offices in Raleigh. The Board shall announce the time and place for each examination at least 10 days before the date of the examination.

(d) Application Process. Each applicant shall complete an application on a form provided by the Board. If the applicant is not an individual, the applicant shall identify on the application any individuals who will take the examination for the applicant. In order to take an examination on a particular date, an applicant shall file a completed application no later than 30 days before the scheduled date of the examination.

(e) Person Taking Examination. A qualifier shall be associated with the applicant, and shall be actively engaged in the work of the applicant for a minimum of 20 hours per week, or a majority of the hours operated by the applicant, whichever is less. Each licensee shall notify the Board in writing within 10 days after any qualifier no longer meets the preceding requirements. If one qualifier fails, and another passes, the license shall be granted to that applicant. An individual shall not serve as a qualifier for more than one license. The applicant may have more than one individual serve as a qualifier.

(f) General Requirements. All applicants scheduled for an examination shall bring a form of identification with a current picture. No visitors shall be allowed in the testing room.

(g) Special Arrangements for the Disabled. If an applicant has a disability which will require special arrangements to take an examination, the applicant shall request in writing that appropriate special arrangements be made. The Board shall make reasonable accommodations for applicants requesting assistance pursuant to this Rule.

(h) Cheating and Related Misconduct. Applicants shall not cheat or attempt to cheat on an examination by any means, including both giving and receiving assistance, and shall not communicate in any manner for any purpose with any person other than staff members for the Board during an examination.

(i) Notification of Results. The examination results shall be mailed to the applicant at the address on the application form within 30 days after the examination. Passing applicants shall receive only a grade of "pass."

(j) Review of Examinations. Upon the applicant's written request, made within 30 days after the written notification of the examination results, an applicant who did not pass the examination shall be allowed to review his examination. The review shall be at the Board's offices, at a time schedule by the Board's staff. An applicant shall review his examination in the presence of a staff member of the Board and shall not be accompanied by any other individual at a review session. No other individual shall review an examination on behalf of the applicant. An applicant shall not be permitted to copy a question or answer contained in the examination report or alter an examination paper in any way. An applicant who has passed the examination shall not be permitted to review his examination. If the applicant is not an individual, the review of the examination shall be made by the applicant's qualifier.

History Note: Authority G.S. 143-143.10(b)(4); 143-143.11(h);

Eff. April 1, 1999;

Pursuant to G.S. 150B-21.3A, rule is necessary without substantive public interest Eff. January 9, 2018.

SECTION .1400 - MANUFACTURED HOUSING BOARD CONTINUING EDUCATION

SECTION .1400 - MANUFACTURED HOUSING BOARD CONTINUING EDUCATION

11 NCAC 08 .1401 DEFINITIONS

As used in this Section:

(1) "Board" means the North Carolina Manufactured Housing Board, as defined in G.S. 143-143.9(1).

(2) "CE Administrator" means a person designated by the Board to receive all applications for course approval, course reports, course application and renewal fees, on behalf of the Board for the CE program.

(3) "Continuing education" or "CE" means any educational activity approved by the Board to be a continuing education activity.

(4) "Course" means a continuing education course directly related to manufactured housing principles and practices or a course designed and approved for licensees.

(5) "Credit hour" means at least 50 minutes of continuing education instruction.

(6) "Distance education course" or "distance learning course" means a continuing education course approved by the Board in which instruction is accomplished through the use of media whereby teacher and student are separated by distance and sometimes by time.

(7) "Licensee" means a manufactured housing salesperson or set-up contractor who holds a license issued by the Board in accordance with G.S. 143-143.11, but does not include a licensed manufacturer or dealer.

(8) "Qualifier" means the person or persons having passed the written Set-Up Contractor's Examination as administered by the Board and authorized in G.S. 143-143.11(h), and as defined in 11 NCAC 08 .0912(e), or a person who meets the requirements of 11 NCAC 08 .0912(e) and is designated by a licensee to obtain CE credits.

(9) "Sponsor" means an organization or individual who has submitted information to the Board as specified in this Section and has been approved by the Board to provide instruction for the purpose of CE.

(10) "Staff" means designated employees of the Manufactured Building Division of the Department of Insurance who are authorized to act on behalf of the Board with regard to continuing education matters.

History Note: Authority G.S. 143-143.10; 143-143.11B;

Eff. August 1, 2002;

Amended Eff. May 1, 2004;

Pursuant to G.S. 150B-21.3A, rule is necessary without substantive public interest Eff. January 9, 2018.

11 NCAC 08 .1402 CE COURSES -- GENERAL

(a) Credit shall be given only for courses that have been approved by the Board. No other continuing education hours for other State occupational licenses shall be used by a licensee to satisfy the continuing education requirements in this Section.

(b) The Board may award CE credit for a course or related educational activity that has not been approved in accordance with 11 NCAC 08 .1405(c). Licensees who wish to have the Board consider an unapproved course or educational activity for possible CE credit shall provide documentation to the Board consisting of not less than the information required in 11 NCAC 08 .1405(a), together with a fee of fifty dollars (\$50.00) for each course or educational activity to be reviewed. Fees shall be paid by check, money order, VISA, or MasterCard, made payable to the North Carolina Manufactured Housing Board, and are nonrefundable.

(c) The minimum credit hours that a licensee must obtain during the license year before renewal are as follows:

Salespersons -- six credit hours;

Set-up Contractors -- four credit hours.

History Note: Authority G.S. 143-143.10; 143-143.11B;

Eff. August 1, 2002;

Pursuant to G.S. 150B-21.3A, rule is necessary without substantive public interest Eff. January 9, 2018.

11 NCAC 08 .1403 SPONSOR ADVANCE APPROVAL REQUIRED

A prospective sponsor of a CE course shall obtain written approval from the Board according to these Rules to conduct the course before offering or conducting the course and before advertising or otherwise representing that the course is or may be approved for continuing education credit in North Carolina. No retroactive approval to conduct a CE course shall be granted by the Board for any reason.

History Note: Authority G.S. 143-143.10; 143-143.11B;

Eff. August 1, 2002;

Pursuant to G.S. 150B-21.3A, rule is necessary without substantive public interest Eff. January 9, 2018.

11 NCAC 08 .1404 SPONSOR NAME

(a) The official name to be used by any course sponsor in connection with the offering of an approved CE course shall clearly distinguish the sponsor from any other previously approved CE course sponsor.

(b) Any advertisement or promotional material used by an approved course sponsor shall include the course sponsor's official name only.

(c) Violations of this Section may result in revocation of course approval.

History Note: Authority G.S. 143-143.10; 143-143.11B;

Eff. August 1, 2002;

Pursuant to G.S. 150B-21.3A, rule is necessary without substantive public interest Eff. January 9, 2018.

11 NCAC 08 .1405 ACCREDITATION STANDARDS

(a) Prospective sponsors of CE courses shall apply for approval from the Board by submitting the following information to the Board for consideration:

(1) The nature and purpose of the course;

(2) The course objectives or goals;

(3) The outline of the course, including the number of training hours for each segment;

(4) Copies of all handouts and materials to be furnished to students;

- (5) The identity, qualifications, and experience of each instructor; and
- (6) Inclement weather policies for courses conducted outdoors.
- (b) A nonrefundable fee of one hundred fifty dollars (\$150.00), in the form of check, money order, VISA, or MasterCard, payable to the North Carolina Manufactured Housing Board, must be received by the Board for each course submitted for approval. The Board will not review a prospective course application before receiving the fee.
- (c) To determine if a course will receive approval, the Board shall complete the following review:
 - (1) The course shall be referred to the staff for review;
 - (2) The staff shall review the course to determine if the course is pertinent to the industry, if the course meets its stated objectives, and if the instructor(s) meets the requirements of 11 NCAC 08 .1418; and
 - (3) The staff shall issue written documentation of approval to the course sponsor, with copies to the Board, for all courses deemed to be acceptable. A written report shall be issued to the course sponsor for all courses found not to be acceptable, documenting specific reasons for the disapproval. A course sponsor may appeal the staff's disapproval of a course to the Board and be heard at the next scheduled meeting of the Board.
- (d) Once a course has been approved, neither the content of the course nor any handouts or any teaching aids may be changed without prior written approval from the staff.

History Note: Authority G.S. 143-143.10; 143-143.11B; 143-143.25;

Eff. August 1, 2002;

Pursuant to G.S. 150B-21.3A, rule is necessary without substantive public interest Eff. January 9, 2018.

11 NCAC 08 .1406 CE COURSE SUBJECT MATTER

- (a) CE courses shall help assure that licensees possess the knowledge, skills, and competence necessary to function as manufactured home salespersons or set-up contractors in a manner that protects and serves the public interest. The knowledge or skills taught in a CE course shall enable licensees to better serve manufactured home consumers and the subject matter shall be directly related to manufactured home sales and set-up operations.
- (b) If there are unique North Carolina laws, codes, rules, customary practices, or approved methods that are relevant to a topic being addressed in a CE course, and if the course is to be conducted in North Carolina or primarily for the benefit of North Carolina licensees, then the course shall accurately and completely address such North Carolina laws, codes, rules, customary practices, or approved methods.
- (c) Instructors shall not communicate any misinformation about or contradiction of any statute, court decision, administrative rule, or order that has been issued by the Board.

History Note: Authority G.S. 143-143.10; 143-143.11B;

Eff. August 1, 2002;

Pursuant to G.S. 150B-21.3A, rule is necessary without substantive public interest Eff. January 9, 2018.

11 NCAC 08 .1407 SCHEDULING

Courses shall be scheduled and conducted in a manner that limits class sessions to a maximum of eight classroom hours in any given day, including breaks for each class session. The maximum permissible class session without a break is 90 minutes. Courses scheduled for more than four hours in any given day shall include a meal break of at least one hour. The provisions of this rule do not apply to distance learning courses.

History Note: Authority G.S. 143-143.10; 143-143.11B;

Eff. August 1, 2002;

Amended Eff. May 1, 2004;

Pursuant to G.S. 150B-21.3A, rule is necessary without substantive public interest Eff. January 9, 2018.

11 NCAC 08 .1408 NOTICE OF SCHEDULED COURSES

- (a) A sponsor shall provide the Board with written notice of each scheduled course offering not later than 10 days before a scheduled course date. The notice shall include the name and assigned number for the sponsor, the name and assigned number for the course, the scheduled date and time, specific location, and name of the instructor(s).
- (b) A sponsor shall notify the Board of any schedule changes or course cancellations at least five calendar days before the original scheduled course date. If a change or cancellation is necessary because of some unforeseen circumstance, the sponsor shall notify the Board as soon as the sponsor effects the change or cancellation.
- (c) A sponsor shall notify the Board as soon as it becomes apparent to the sponsor that enrollment in a planned class session will exceed 100 students.

(d) Distance learning courses shall be advertised in accordance with 11 NCAC 08 .1409 and shall be posted on the North Carolina Department of Insurance website.

History Note: Authority G.S. 143-143.10; 143-143.11B;

Eff. August 1, 2002;

Amended Eff. May 1, 2004;

Pursuant to G.S. 150B-21.3A, rule is necessary without substantive public interest Eff. January 9, 2018.

11 NCAC 08 .1409 ADVERTISING AND PROVIDING COURSE INFORMATION

(a) Course sponsors shall not use advertising of any type that is false or misleading. If the number of CE credit hours awarded by the Board for an approved CE course is less than the number of scheduled hours for the course, any course advertisement or promotional materials that indicate the course is approved for CE credit shall specify the number of CE credit hours awarded by the Board for the course.

(b) Any flyers, brochures, or other medium used to promote a CE course shall clearly describe the fee to be charged and the sponsor's cancellation and fee refund policies. Such policies shall be in accordance with 11 NCAC 08 .1411.

(c) A sponsor of a CE course shall, upon request, provide any prospective student with a description of the course content.

History Note: Authority G.S. 143-143.10; 143-143.11B;

Eff. August 1, 2002; Pursuant to G.S. 150B-21.3A, rule is necessary without substantive public interest Eff. January 9, 2018.

11 NCAC 08 .1410 SOLICITATION OF STUDENTS

Sponsors and instructors may make available for purchase by students unapproved materials, pamphlets, and brochures that belong to the sponsor, instructor, or some other person. However, class time shall not be used to promote or sell any materials or to solicit affiliation or membership in any business or organization. Unapproved materials shall not be used as teaching aids during the class.

History Note: Authority G.S. 143-143.10; 143-143.11B;

Eff. August 1, 2002;

Pursuant to G.S. 150B-21.3A, rule is necessary without substantive public interest Eff. January 9, 2018.

11 NCAC 08 .1411 CANCELLATION AND REFUND POLICIES

Course sponsors shall administer course cancellation and fee refund policies in a non-discriminatory manner. Such policies shall be clearly defined in course advertising and information as outlined in 11 NCAC 08 .1409. If a scheduled course is canceled, a sponsor shall notify preregistered students of the cancellation. All prepaid fees received from preregistered students shall be refunded within 30 days after the date of cancellation or, with the student's permission, applied toward the fees for another course.

History Note: Authority G.S. 143-143.10; 143-143.11B;

Eff. August 1, 2002;

Pursuant to G.S. 150B-21.3A, rule is necessary without substantive public interest Eff. January 9, 2018.

11 NCAC 08 .1412 DENIAL OR WITHDRAWAL OF APPROVAL OF COURSE OR COURSE SPONSOR

The Board shall deny or withdraw approval of any course or course sponsor upon finding that:

(1) The course sponsor has made any false statements or presented any false information in connection with an application for course or sponsor approval or renewal of the approval.

(2) The course sponsor or any official or instructor employed by or under contract with the course sponsor has refused or failed to comply with any of the provisions of this Section.

(3) The course sponsor or any official or instructor employed by or under contract with the course sponsor has provided false or incorrect information in connection with any reports the course sponsor is required to submit to the Board.

(4) The course sponsor has engaged in a pattern of consistently canceling scheduled courses.

(5) The course sponsor has knowingly paid fees to the Board with a check that was dishonored by a bank.

(6) An instructor employed by or under contract with the course sponsor fails to conduct approved courses in a manner that demonstrates compliance with the instructor requirements described in 11 NCAC 08 .1418.

(7) Any court of competent jurisdiction has found the course sponsor to have violated, in connection with the offering of CE courses, any applicable federal or state law or regulation prohibiting discrimination on the basis of disability, requiring places of public accommodation to be in compliance with prescribed accessibility standards, or requiring that courses related to licensing or certification for professional or trade purposes be offered in a place and manner accessible to persons with disabilities.

(8) The course sponsor has failed to comply with cancellation and refund policies as outlined in 11 NCAC 08 .1411.

History Note: Authority G.S. 143-143.10; 143-143.11B;

Eff. August 1, 2002;

Pursuant to G.S. 150B-21.3A, rule is necessary without substantive public interest Eff. January 9, 2018.

11 NCAC 08 .1413 RENEWAL OF COURSE AND SPONSOR APPROVAL

(a) Board approval of all CE courses and course sponsors shall expire one year following the date of approval. In order to assure continuous approval, renewal applications shall be accompanied by the prescribed renewal fee and filed with the Board not later than 30 days prior to the date of expiration. Any incomplete renewal application received 30 days or more prior to the date of expiration that is not completed within 10 days after notice of the deficiency, as well as any renewal application received less than 30 days prior to the date of expiration, shall not be accepted. For renewal applications received less than 30 days prior to the date of expiration, the sponsor shall file an application for original approval in accordance with 11 NCAC 08 .1405 on or after July 1 in order to be reapproved. Fees as prescribed in 11 NCAC 08 .1405 shall apply for all such reapprovals.

(b) The fee for renewal of Board approval shall be seventy-five dollars (\$75.00) for each CE course for sponsors meeting the deadlines specified in Paragraph (a) of this Rule. Fees shall be paid by check, money order, or Visa / MasterCard made payable to the North Carolina Manufactured Housing Board and are nonrefundable.

History Note: Authority G.S. 143-143.10; 143-143.11B;

Eff. August 1, 2002;

Pursuant to G.S. 150B-21.3A, rule is necessary without substantive public interest Eff. January 9, 2018.

11 NCAC 08 .1414 SPONSOR CHANGES DURING APPROVAL PERIOD

(a) Course sponsors shall give prior written notice to the Board in writing of any change in business name, Continuing Education Coordinator, address, or business telephone number.

(b) Course sponsors shall obtain prior approval from the Board for any proposed changes in the content or number of hours for CE courses. The Board shall approve the changes if they satisfy the accreditation requirements of 11 NCAC 08 .1405. Changes in course content that are solely for the purpose of assuring that information provided in a course is current, such as code amendments, changes in regulations, etc., need not be reported until the time the sponsor requests renewal of course approval as specified in 11 NCAC 08 .1413. Requests for approval of changes shall be in writing.

History Note: Authority G.S. 143-143.10; 143-143.11B;

Eff. August 1, 2002;

Pursuant to G.S. 150B-21.3A, rule is necessary without substantive public interest Eff. January 9, 2018.

11 NCAC 08 .1415 CE REQUIREMENTS

(a) In order to renew an active manufactured housing salesperson or set-up contractor license for license periods beginning on or after July 1, 2003, and in accordance with G.S. 143-143.11B(a), a licensee shall have completed the number of credit hours specified in this Paragraph, by June 30 of the previous license year. Salespersons shall complete six credit hours and set-up contractors shall complete four credit hours. If a licensee exceeds the number of credit hours specified in this Paragraph, the excess credit hours may be carried forward into the next license year, but the number of carry over credit hours may not exceed the number specified in this Paragraph. In addition to the specific requirements stated in this Rule, a Law and Administration course consisting of at least six hours of continuing education for salespersons and at least four hours of continuing education for set-up contractors shall be required to be taken for continuing education credit at least once in every five year period beginning July 1, 2004. In license periods in which a salesperson or set-up contractor takes an approved Law and Administration course, no additional courses shall be required during that license period. All Law and Administration courses taken for credit shall be submitted to and approved by the Board in accordance with 11 NCAC 08 .1405 and 11 NCAC 08 .1433.

(b) For set-up contractors originally licensed on or after July 15, 1999, the person obtaining the required credit hours must be a qualifier. If a set-up contractor licensed on or after July 15, 1999 has more than one qualifier, each qualifier must obtain the required number of CE credits for the license period. For set-up contractors originally licensed prior to July 15, 1999, the licensee shall designate an individual, known as the "qualifier," who is associated with the licensee and is actively engaged in the work of the licensee for a minimum of 20 hours per week or a majority of the hours operated by the licensee, whichever is less. The qualifier shall be the person who obtains CE credits on behalf of the licensee. Each licensee shall notify the Board in writing within 10 days after the qualifier no longer meets the preceding requirements. If a qualifier has obtained excess credit hours which may be carried over into the subsequent license year, and no longer meets the requirements of this Section, the carry over credits shall not apply to the licensee. If the qualifier becomes employed by another licensee and meets the requirements of this Section, the qualifier's carry over credit hours may be applied to the licensee with whom the qualifier is newly employed for the current license year. A licensee whose qualifier no longer meets the requirements of this Section must designate another qualifier who shall obtain the required credit hours for the subsequent license year.

(c) A licensee who is initially licensed on or after January 1 in any license year is exempt from this Section for the license period expiring on the next June 30.

(d) A licensee who is qualified as an instructor in accordance with 11 NCAC 08 .1418 and who serves as an instructor for an approved CE course shall receive the maximum credits for the course taught by the instructor that are awarded to a student for the course. However, teaching credit is valid for teaching an approved CE course or seminar for the first time only.

History Note: Authority G.S. 143-143.10; 143-143.11B;

Eff. August 1, 2002;

Amended Eff. May 1, 2004;

Pursuant to G.S. 150B-21.3A, rule is necessary without substantive public interest Eff. January 9, 2018.

11 NCAC 08 .1416 CONTINUING EDUCATION COORDINATOR

Every sponsor of a CE course shall designate one person to serve as the Continuing Education Coordinator for all Board-approved continuing education courses offered by the sponsor. The designated Coordinator shall serve as the official contact person for the sponsor and shall be responsible for the following:

(1) Monitoring the attendance and conduct of students in accordance with 11 NCAC 08 .1417 and 11 NCAC 08 .1419 at the sponsor's Board-approved CE courses;

(2) Signing the course completion certificates provided by the sponsor to licensees completing courses; and

(3) Submitting to the Board all required fees, rosters, reports, and other information.

History Note: Authority G.S. 143-143.10; 143-143.11B;

Eff. August 1, 2002;

Pursuant to G.S. 150B-21.3A, rule is necessary without substantive public interest Eff. January 9, 2018.

11 NCAC 08 .1417 MONITORING ATTENDANCE

(a) Continuing Education Coordinators, or their designees, shall monitor attendance for the duration of each class session to assure that all students reported as satisfactorily completing a course have attended at least 90 percent of the scheduled classroom hours, regardless of the length of the course. Students shall not be admitted to a class session after 10 percent of the scheduled classroom hours have been conducted. A student shall not be allowed to sign a course attendance roster report, shall not be issued a course completion certificate, and shall not be reported to the Board as having completed a course unless the student fully satisfies the attendance requirement. Sponsors and instructors shall not make any exceptions to the attendance requirement for any reason.

(b) Sponsors shall assure that, if necessary, adequate personnel in addition to the instructor are present during all class sessions to assist the instructor in monitoring attendance and performing the administrative tasks associated with conducting a course. Sponsors shall assure that time required for administrative tasks does not interfere with designated minimum instruction time.

History Note: Authority G.S. 143-143.10; 143-143.11B;

Eff. August 1, 2002;

Pursuant to G.S. 150B-21.3A, rule is necessary without substantive public interest Eff. January 9, 2018.

11 NCAC 08 .1418 INSTRUCTOR REQUIREMENTS

(a) Instructors shall assure that class sessions are started on time and are conducted for the full amount of time that is scheduled. Instructors shall also assure that each CE course is taught according to the course outline and plan that was approved by the Board, including the furnishing of approved student materials.

(b) Instructors shall possess the ability to:

(1) Communicate through speech, with the ability to speak clearly, and with voice inflection, using proper grammar, and vocabulary;

(2) Present instruction in a thorough, accurate, logical, orderly and understandable manner;

(3) Use varied instructional techniques in addition to straight lecture, such as class discussion, role-playing, or other techniques; and

(4) Use instructional aids, such as the overhead projector, to enhance learning.

History Note: Authority G.S. 143-143.10; 143-143.11B;

Eff. August 1, 2002;

Pursuant to G.S. 150B-21.3A, rule is necessary without substantive public interest Eff. January 9, 2018.

11 NCAC 08 .1419 STUDENT PARTICIPATION STANDARDS

(a) In addition to requiring student compliance with the attendance requirement, sponsors and instructors shall require that students comply with the following student participation standards:

(1) A student shall direct his or her attention to the instruction being provided and refrain from engaging in activities unrelated to the instruction.

(2) A student shall refrain from engaging in any activities that are distracting to other students or the instructor, or that otherwise disrupt the orderly conduct of a class.

(3) A student shall comply with all instructions provided by the sponsor or instructor related to providing information needed to properly report completion of a course by the student.

(b) Instructors and sponsors may dismiss from a class session any student who fails to comply with the student participation standards prescribed in Paragraph (a) of this Rule.

(c) Sponsors shall not issue a course completion certificate to any student who fails to comply with the student participation standards set forth in Paragraph (a) of this Rule, nor shall a sponsor include the name of that student on a report verifying completion of a CE course. A sponsor shall submit to the Board with the report for the class session a written statement that includes the name and license number of each student for whom the sponsor does not report course credit, details concerning the student's failure to comply with the student participation standards, and names of other persons in attendance at the class who witnessed the student's conduct.

History Note: Authority G.S. 143-143.10; 143-143.11B;

Eff. August 1, 2002;

Pursuant to G.S. 150B-21.3A, rule is necessary without substantive public interest Eff. January 9, 2018.

11 NCAC 08 .1420 STUDENT FEE FOR CE COURSES

The sponsor of an approved CE course may establish the amount of the fee to be charged to students taking the course. The established fee shall be an all-inclusive fee, and no separate or additional fee may be charged to students for providing course materials as described in 11 NCAC 08 .1405(a)(4), providing course completion certificates, reporting course completion to the Board, or for recouping similar routine administrative expenses. The total amount of any fees to be charged shall be included in any advertising or promotional materials for the course.

History Note: Authority G.S. 143-143.10; 143-143.11B;

Eff. August 1, 2002;

Pursuant to G.S. 150B-21.3A, rule is necessary without substantive public interest Eff. January 9, 2018.

11 NCAC 08 .1421 MINIMUM CLASS SIZE

The minimum class size for any session of an approved CE course shall be five students, as determined by the sponsor's preregistration records. The minimum class size requirement shall not apply to class sessions when the sponsor notifies the Board in writing of the scheduled class session as provided in 11 NCAC 08 .1408 and advertises in advance the scheduled class session in the community where the class session is to be held. A sponsor who conducts a class session for fewer than five students shall submit a copy of the advertisement for the class session

with the reports verifying completion of the course plus a statement or other documentation indicating the date of the advertisement and the advertising method.

History Note: Authority G.S. 143-143.10; 143-143.11B;

Eff. August 1, 2002;

Pursuant to G.S. 150B-21.3A, rule is necessary without substantive public interest Eff. January 9, 2018.

11 NCAC 08 .1422 CLASSES OPEN TO ALL LICENSEES

All class sessions of approved CE courses shall be open to all licensees on a first-come, first-served basis. The sponsor of a course that has a bona fide education or experience prerequisite may refuse admission to a licensee who does not satisfy the prerequisite. A sponsor may contract with an organization such as a manufactured home set-up company, dealership, or trade organization to conduct approved CE courses for licensees affiliated with the organization.

History Note: Authority G.S. 143-143.10; 143-143.11B;

Eff. August 1, 2002;

Pursuant to G.S. 150B-21.3A, rule is necessary without substantive public interest Eff. January 9, 2018.

11 NCAC 08 .1423 CLASSROOM FACILITIES

A classroom in which a course is provided shall:

- (1) Accommodate all enrolled students;
- (2) Be equipped with student desks, worktables with chairs, or other seating arrangement which provides a surface whereby each student can sit and write;
- (3) Have light, heat, cooling, and ventilation;
- (4) Have, if required, a public address system such that all students can hear the instructor clearly;
- (5) Provide a direct, unobstructed line of sight from each student to the instructor and all teaching aids; and
- (6) Be free of distractions that would disrupt class sessions. Items (2) and (3) of this Rule are not required if the course is conducted in a field setting.

History Note: Authority G.S. 143-143.10; 143-143.11B;

Eff. August 1, 2002;

Pursuant to G.S. 150B-21.3A, rule is necessary without substantive public interest Eff. January 9, 2018.

11 NCAC 08 .1424 STUDENT CHECK-IN

Upon initially checking in for a class session, sponsors and instructors shall require licensees to provide their manufactured housing salesperson license number or set-up contractor license number and qualifier number. Student identity shall be verified by a photo identification issued to the student by a federal, state or local government agency. The CE Administrator shall verify information reported in accordance with 11 NCAC 08 .1426(a) regarding each student's license number, qualifier number, and current license status. Any student providing false information to a course sponsor shall not receive CE credits for the course, shall not be entitled to a refund of course fees, and may be subject to disciplinary action by the Board.

History Note: Authority G.S. 143-143.10; 143-143.11B;

Eff. August 1, 2002;

Pursuant to G.S. 150B-21.3A, rule is necessary without substantive public interest Eff. January 9, 2018.

11 NCAC 08 .1425 ACCOMMODATIONS FOR PERSONS WITH DISABILITIES

Course sponsors may deviate from Board rules concerning the conduct of CE courses, such as rules addressing classroom facilities, minimum class size, and instructional methods, as may be necessary in order for the sponsor to comply with the Americans with Disabilities Act or other laws requiring sponsors to accommodate persons with disabilities. A sponsor providing a special accommodation for a licensee with a disability that requires the sponsor to deviate from Board rules shall notify the Board in writing of the accommodation at the time reports are submitted for the class session attended by the licensee.

History Note: Authority G.S. 143-143.10; 143-143.11B;

Eff. August 1, 2002;

Pursuant to G.S. 150B-21.3A, rule is necessary without substantive public interest Eff. January 9, 2018.

11 NCAC 08 .1426 COURSE COMPLETION REPORTING

(a) The Continuing Education Coordinator designated by the sponsor in accordance with 11 NCAC 08 .1416 shall prepare and submit to the Board reports verifying completion of a CE course for each licensee who satisfactorily completes the course according to the criteria in 11 NCAC 08 .1417 and 11 NCAC 08 .1419. The reports shall be submitted in the manner and format as prescribed by this Rule. Sponsors shall submit these reports to the attention of the CE Administrator such that receipt by the Board within 15 calendar days following the course is assured, but in no case later than June 1 for courses conducted before that date. The report shall be submitted to the attention of the CE Administrator. For each course taken, such report shall include a certificate of course completion that is signed by at least one course instructor and shall indicate the name and license number of the licensee who completed the course, the date of course completion, and the number of credit hours granted to the licensee. A fee of five dollars (\$5.00) per credit hour per licensee must be provided by the sponsor with this information, and shall be by check, money order, or Visa / MasterCard made payable to the North Carolina Manufactured Housing Board. The same course shall not be repeated and reported for credit by a licensee within any three year period. No refund of required fees shall be issued for any course credits that are rejected for this reason. The sponsor shall make a separate fee payment for each separate class session.

(b) Course sponsors shall provide licensees enrolled in each CE course an opportunity to complete an evaluation of each approved CE course. Sponsors shall submit the completed evaluation forms to the Board along with the reports that verify completion of a CE course. Evaluation forms shall be reviewed to determine course problem areas and to verify compliance with these Rules.

(c) Course sponsors shall provide each licensee who satisfactorily completes an approved CE course according to the criteria in 11 NCAC 08 .1417 and 11 NCAC 08 .1419 a course completion certificate. Sponsors shall provide the certificates to licensees within 15 calendar days following the course, but in no case later than June 1 for any course completed before that date. The certificate may be retained by the licensee as proof of having completed the course.

(d) When a licensee does not comply with the participation standards in 11 NCAC 08 .1419, the course sponsor shall advise the Board of this matter in writing at the time the sponsor submits the reports verifying completion of the course as specified in Paragraph (a) of this Rule. The sponsor who determines that a licensee failed to comply with either the Board's attendance or student participation standards in 11 NCAC 08 .1417 and 11 NCAC 08 .1419 shall not provide the licensee with a course completion certificate nor shall the sponsor include the licensee's name on the reports verifying completion of continuing education. Such persons shall be reported to the CE Administrator as specified in 11 NCAC 08 .1419(c).

History Note: Authority G.S. 143-143.10; 143-143.11B;

Eff. August 1, 2002;

Pursuant to G.S. 150B-21.3A, rule is necessary without substantive public interest Eff. January 9, 2018.

11 NCAC 08 .1427 RETENTION OF COURSE RECORDS

All course sponsors shall retain records of student registration, attendance, and course completion for each session of a CE course for five years. All course sponsors shall make these records available to the Board upon request.

History Note: Authority G.S. 143-143.10; 143-143.11B;

Eff. August 1, 2002;

Pursuant to G.S. 150B-21.3A, rule is necessary without substantive public interest Eff. January 9, 2018.

11 NCAC 08 .1428 REQUEST FOR VIDEO OF AN ELECTIVE COURSE

If concerns about the quality of a course or instructor are made known to the Board, the Board shall, through written request, require that the sponsor of an approved CE course submit to the Board a video depicting the course being taught by a particular instructor or instructors specified by the Board. If not already available, the video shall be produced at the next scheduled course offering. A video produced within a 12-month period preceding the date of submittal shall be acceptable. All videos shall include a label that clearly identifies the instructor and the date of the video presentation, and shall be 45-60 minutes in length. The video shall depict a continuous block of instruction concerning manufactured home salesperson requirements or set-up contractor operations, shall be unedited, shall show at least a portion of the audience, and shall have visual and sound quality sufficient to enable reviewers to clearly see and hear the instructor. Videos requested by the Board shall be shipped within 10 calendar days of

receiving the request or within two weeks after course completion. The cost of producing and shipping such videos shall be borne solely by the course sponsor.

History Note: Authority G.S. 143-143.10; 143-143.11B;

Eff. August 1, 2002;

Pursuant to G.S. 150B-21.3A, rule is necessary without substantive public interest Eff. January 9, 2018.

11 NCAC 08 .1429 CHANGE IN SPONSOR OWNERSHIP

The approval granted to a course sponsor may be transferred to a new or different person, firm, or corporation only with the prior approval of the Board. The Board shall approve the transfer if the transferee satisfies the accreditation requirements as specified in 11 NCAC 08 .1405. If the ownership of an approved course sponsor is to be sold or otherwise changed, the sponsor shall obtain Board approval of the ownership change. The Board shall approve the ownership change if the proposed new owner satisfies the requirements of the Rules in this Section. All requests for Board approval of transfers or changes in ownership shall be in writing and shall be accompanied by a fee of one hundred fifty dollars (\$150.00). Fees shall be paid by check, money order, or Visa / MasterCard made payable to the North Carolina Manufactured Housing Board and are nonrefundable.

History Note: Authority G.S. 143-143.10; 143-143.11B;

Eff. August 1, 2002;

Pursuant to G.S. 150B-21.3A, rule is necessary without substantive public interest Eff. January 9, 2018.

11 NCAC 08 .1430 COURSE MONITORS

A course sponsor shall admit authorized representatives of the Board to monitor any CE class without prior notice. Board representatives shall not be required to register or pay any fee and shall not be reported as having completed the course.

History Note: Authority G.S. 143-143.10; 143-143.11B;

Eff. August 1, 2002;

Pursuant to G.S. 150B-21.3A, rule is necessary without substantive public interest Eff. January 9, 2018.

11 NCAC 08 .1431 NON-RESIDENT LICENSEES AND CE CREDITS

A non-resident licensee may obtain required CE credits as set forth in this section. If a non-resident licensee resides in a state requiring continuing education for a manufactured housing license, the courses or educational activities offered in the state of residence may be considered by the Board for sanctioning in North Carolina on an individual course basis. Licensees who wish to have the Board consider courses or educational activities offered in states other than North Carolina for possible CE credit shall provide documentation to the Board consisting of not less than the information required in 11 NCAC 08 .1405(a), together with a fee of fifty dollars (\$50.00) for each course or educational activity to be reviewed. Fees shall be paid by check, money order, or Visa/MasterCard made payable to the North Carolina Manufactured Housing Board and are nonrefundable.

History Note: Authority G.S. 143-143.10; 143-143.11B;

Eff. August 1, 2002;

Pursuant to G.S. 150B-21.3A, rule is necessary without substantive public interest Eff. January 9, 2018.

11 NCAC 08 .1432 NON-COMPLIANCE

If a licensee fails to complete the CE requirements specified in these Rules by June 30 of a given license year, his or her license shall not be renewed. A licensee may renew at any time prior to the following June 30, but may not operate as either a manufactured housing salesperson or set-up contractor until such time as documentation of having completed the CE requirements is furnished to the Board and the license has been renewed. A licensee who has not completed the CE requirements within one year of the original expiration shall be required to pass written State examinations in order to be re-licensed.

History Note: Authority G.S. 143-143.10; 143-143.11B;

Eff. August 1, 2002;

Pursuant to G.S. 150B-21.3A, rule is necessary without substantive public interest Eff. January 9, 2018.

11 NCAC 08 .1433 DISTANCE EDUCATION COURSES

A sponsor requesting approval of a distance education course shall comply with 11 NCAC 08 .1405. Additionally, the proposed distance education course shall satisfy the following criteria, as applicable:

- (1) The course shall be designed to assure that students have defined learning objectives. If the nature of the subject matter is such that the learning objectives cannot be reasonably accomplished without some direct interaction between the instructor and students, then the course shall be designed to provide for such interaction.
- (2) A course that does not provide the opportunity for continuous audio and visual communication between instructor and all students during the course presentation shall utilize testing processes that assure student mastery of the subject material.
- (3) A course that involves students completing the course on a self-paced study basis shall be designed so that the time required for a student of average ability to complete the course will be not less than six hours for salespersons and four hours for set-up contractors. The sponsor shall utilize a system that assures that students have actually performed all tasks required for completion and mastery of the subject material.
- (4) The sponsor shall provide technical support to enable students to satisfactorily complete the course.
- (5) The approved course instructor(s) shall be available to respond in a timely manner to student questions about the subject matter of the course. Instructors shall have training in the proper use of the instructional delivery method utilized in the course, including the use of computer hardware and software or other applicable equipment and systems.
- (6) The sponsor shall provide students an orientation or information package containing all pertinent information regarding requirements unique to completing a distance education course, including any requirements with regard to computer hardware and software or other equipment, and outlining in detail the instructor and technical support that will be available when taking the course.
- (7) The sponsor shall utilize procedures that provide reasonable assurance that the student receiving continuing education credit for completing the course actually performed, on his or her own, all the work required to complete the course. For courses that involve independent study by students, certification that the student personally completed all required course work shall be provided by the student to the sponsor, either by a signed statement (on a form provided by the sponsor) or, in the case of Internet or computer based courses, by electronic means that are indicated in the software or on the website. Signed course completion statements or records of electronic certification shall be retained by the sponsor together with any other course records required by this Section.
- (8) In addition to the information required in 11 NCAC 08 .1405, sponsors seeking approval of distance education courses must submit to the Board a complete copy of the course in the medium that is to be utilized, including all computer software that will be used in presenting the course and administering tests. If the course is to be Internet based, the Board must be provided access to the course via the Internet and shall not be charged a fee for such access.
- (9) All reporting of completed distance education courses shall be in full accordance with 11 NCAC 08 .1426. Students shall not be reported for continuing education credit for distance education courses until the signed form from the student or electronic certification, as described in Item (7) of this Rule, has been received.

History Note: Authority G.S. 143-143.10; 143-143.11B;

Eff. May 1, 2004;

Pursuant to G.S. 150B-21.3A, rule is necessary without substantive public interest Eff. January 9, 2018.

APPENDIX L

24 CFR PART 3282 MANUFACTURED HOME PROCEDURAL AND ENFORCEMENT REGULATIONS

NORTH CAROLINA STATE PLAN

North Carolina Department of Insurance State Administrative Agency

Approved by the Department of Housing and Urban Development: 03/19/2019

SP.1 The North Carolina Department of Insurance, Manufactured Building Division, hereinafter known as the State Administrative Agency, will handle consumer complaints concerning standards-related problems in manufactured homes. Complaint Hearings in the resolution of complaints will be heard before the NC Manufactured Housing Board in accordance the *General Statutes of North Carolina 143-143.8 through 143-151.7*, the *North Carolina Administrative Procedures Act*, the *North Carolina Administrative Code, Title 11 Sections C8.0900 Manufactured Housing Board and C8.1400 Manufactured Housing Board Continuing Education*, the *State of North Carolina Regulations for Manufactured Homes, 2019 Edition* and *24 CFR 3288 Manufactured Home Dispute Resolution Program*. Presentation of Views, if necessary, will be administered by the Manufactured Building Division in accordance with *24 CFR 3282 Subpart I Section of Manufactured Home Procedural Rules and Enforcement Regulations*

SP.2 The North Carolina Department of Insurance, Manufactured Building Division, the State Administrative Agency for HUD Manufactured Homes in North Carolina will inspect and initiate any appropriate action or proceedings to prevent, restrain or correct any violation of the *24 CFR 3282 Manufactured Home Procedural Rules and Enforcement Regulations and the State of North Carolina Regulations for Manufactured Homes, 2019 Edition*. Such authority being given by the *General Statutes of the State of North Carolina 143-143.8 through 143-151.7* and such additional authority as granted by HUD as the State Administrative Agency for Manufactured Homes in North Carolina per *24 CFR 3282 Subpart G Manufactured Home Procedural Rules and Enforcement Regulations*.

SP.3 All warranty complaints concerning manufactured housing will be handled by the North Carolina Manufactured Housing Board in accordance with provisions *North Carolina General Statutes 143.143.8 through 143-151.7* entitled *Article 9A, North Carolina Manufactured Housing Board -- Manufactured Home Warranties, Article 9B Uniform Standards Code For Manufactured Homes and 24 CFR 3288 Manufactured Home Dispute Resolution Program*.

SP.4 Notification and correction procedures will be followed by the State Administrative Agency as set forth in *Subpart I – Consumer Complaint Handling and Remedial Actions* of the *24 CFR 3282 Manufactured Home Procedural Rules and Enforcement Regulations*.

SP.5 The State Administrative Agency will monitor the remedial action carried out by manufacturers where State Administrative Agency has approved plans for correction or notification and for which State Administrative Agency will also monitor periodically the manufacturers' handling of consumer complaints by checking his records against State Administrative Agency records in each plant or home office in accordance with *Subpart I – Consumer Complaint Handling and Remedial Actions* of the *24 CFR 3282 Manufactured Home Procedural Rules and Enforcement Regulations*.

SP.6 Monitoring inspection fees will be established in the amount as required by the Secretary of HUD in accordance with *24 CFR 3282.307 – Monitoring Inspection Fee Establishment and Distribution*. Additional reasonable inspection fees may be imposed by the State to offset expensed incurred by the State in conducting inspections. Such fees shall be part of the State Plan and shall be subject to approval by the Secretary.

SP.7 We have legal authority necessary to carry out the State Plan as per *24 CFR 3282 Subpart G Manufactured Home Procedural Rules and Enforcement Regulations, North Carolina General Statutes 143-144 through 143-151.7, the North Carolina Administrative Procedures Act, The North Carolina Administrative Code, Title 11C8-.0900* and the *State of North Carolina Regulations for Manufactured Homes, 2019 Edition*.

SP.8 HUD will be furnished a list of staff of the North Carolina Department of Insurance and their qualifications who are available to carry out the State Plan. As personnel are added, this list will be updated. (See Attached)

SP.9 HUD will be furnished resumes of administrative personnel in policy making positions and resumes of all inspectors and engineers utilized in carrying out State Plan. (See Attached)

SP.10 HUD will be furnished a Conflict of Interest certification for SAA staff members involved in carrying out the State Plan. The Conflict of Interest Certification shall indicate that no staff member involved in carrying out the State Plan will have a conflict of interest as of the type described in 24 CFR 3282 Section 3282.359. North Carolina does hereby certify that all of its current staff members involved in carrying out the State Plan are not in any way subject to a conflict of interest of the type discussed in 24 CFR 3282 Section 3282.359 or otherwise. North Carolina will provide HUD with an Individual Conflict of Interest Certification statement upon the hiring of any new staff members involved in carrying out the State Plan.

SP.11

The estimated cost of the State of North Carolina for carrying out the activities called for the State Plan is as follows:

| | |
|--------------------|--------------|
| Consumer Complaint | \$400,000.00 |
| Monitoring | \$350,000.00 |

SP.12 The State of North Carolina is presently allocating necessary funds and personnel to the administration and enforcement of regulations of manufactured homes and the State Administrative Agency will continue to make all efforts to the end that adequate State funds are available for carrying out the State Plan.

SP.13 Manufacturers and dealers will maintain and submit reports as required by HUD in accordance *24 CFR 3282 Subpart L Manufactured Home Procedural Rules and Enforcement Regulations* and with *North Carolina General Statutes 143-151.3*.

SP.14 The State Administrative Agency will submit reports as required by *24 CFR 3282 Subpart L Manufactured Home Procedural Rules and Enforcement Regulations*.

SP.15 STATE PLAN - ADDITIONAL PROVISIONS

SP.15.1 Inspections on Dealer Lots - State officials will make inspections of dealer lots periodically for these purposes:

SP.15.1.1 Inspection of Dealer’s Lots for Dealers’ General Performance - State officials will inspect dealer lots in order to verify dealers compliances with Dealer Responsibilities as indicated in NC General Statutes 143-143.8 through 143-151.7 *NC APA Rules Section 11-NCAC 08.900-Manufactured Housing Board and Section 11 NCAC 08.1400 – Manufactured Housing Board Continuing Education* and Federal Responsibilities as indicated in *24 CFR 3282 Manufactured Home Procedural Rules and Enforcement Regulations*.

SP.15.1.2 Inspection of Dealer Lots to insure Dealers and Salespersons are properly licensed - State officials will inspect dealer lots in order to verify dealers and salespersons compliance with licensing requirements in accordance with *NC General Statutes 143-143.8 – 143-143.49 – North Carolina Manufactured Housing Board – Manufactured Home Warranties* and *NC APA Rules Section 11-NCAC 08.900-Manufactured Housing Board and Section 11 NCAC 08.1400 – Manufactured Housing Board Continuing Education*

SP.15.1.3 Inspection of Dealer Lots to insure compliance with Escrow Account requirements - State officials will inspect dealer lots in order to verify Dealers and Salespersons are complying with Escrow Account requirements for handling consumer deposits in accordance with *NC General Statutes 143-143.50 – 143-143.54 – Buyer Deposit, Escrow or Trust Accounts*

SP.15.1.4 Inspection of Dealer Lots for Transit Damage, Seal Tampering, and Non-Conformance with the Federal Regulations - State officials will inspect homes located on dealer lots in order to verify:

SP.15.1.4.1 Used manufactured homes, manufactured between September 1, 1971 and June 15, 1976, will be checked to insure home has a North Carolina Approved Inspection Agency “Validating Stamp” applied thereon as required by *NC General Statutes 143-149*.

SP.15.1.4.2 Used manufactured homes, manufactured under the HUD Federal Manufactured Home Program on or after June 15, 1976, will be checked to insure home has a HUD Certification Label applied thereon as required by the in *24 CFR Section 3280.11 Manufactured Home Construction and Safety Standards and dealer lot installations in accordance the State of North Carolina Regulations for Manufactured Homes, 2019 Edition or Section 24 CFR 3285.2 Model Manufactured Home Installation Standards*.

SP.15.1.4.3 New HUD manufactured homes, manufactured under the HUD Federal Manufactured Home Program will be checked for compliance with the following in accordance with *24 CFR 3282 Manufactured Home Procedural Rules and Enforcement Regulations, 24 CFR 3280 Manufactured Home Construction and Safety Standards* for the following:

- Seal Tampering
- Transit and/or dealer lot installation damage
- Dealer lot installations in accordance in accordance with *Section 24 CFR 3285.2 Model Manufactured Home Installation Standards*.
- Obvious code violations with the Federal Regulations as indicated in *24 CFR 3280 Manufactured Home Construction and Safety Standards*

Note: Obvious code violations with the Federal Standards found in new homes by inspectors during dealer lot inspections will be reported in writing to the manufacturer, the State Administrative Agency of the state of manufacturer and to the dealer who will be informed that the home cannot be sold until all code violations with Federal Standards has been corrected. The State Administrative Agency will keep records of serial number and label number of new homes which have been found on dealer lots to contain code violations with the Federal Standard.

SP.15.1.5 Monitoring Dealers' Lots for Alterations. State officials will periodically conduct monitoring inspections of dealers' lots as follows:

SP.15.1.5.1 New HUD Labeled homes will be inspected for unauthorized field alterations.

Unauthorized field alterations found will be noted. The dealer, manufacturer, and State Administrative Agency of the state of manufacturer will be informed in writing that they cannot sell homes with unauthorized field alterations which are not in conformance with Federal Standards until such time as all unauthorized field alterations have been inspected and approved as being in compliance with the Federal Regulations. The State Administrative Agency will keep records of serial number and label number of new homes which have been found on dealer lots to contain unauthorized field alterations with the Federal Standards.

SP.15.6 Monitoring of New and Used Manufactured Home Installations. The State Administrative Agency will monitor inspections made by local inspection departments to assure that foundations, utility connections, connections between units and tie-downs of all manufactured homes are in compliance with State and Federal Regulations as indicated in the *24 CFR 3286 Subpart I-State Program* as approved by HUD, *State of North Carolina Regulations for Manufactured Homes, 2019 Edition* or *Section 24 CFR 3285.2 Model Manufactured Home Installation Standards* and *Section 24 CFR 3282.14 Alternative Construction of Manufactured Homes* or *24 CFR 3282 Subpart M – On-Site Completion of Construction of Manufactured Homes*

SP.15.7 Monitoring Repairs of New and Used Manufactured Homes - The State Administrative Agency will monitor repairs on new and used manufactured homes in accordance with the following:

SP.15.7.1 Monitoring Repairs of New Manufactured Homes - The State Administrative Agency will monitor repairs on new manufactured homes to insure all repairs are made and inspected for compliance with *24 CFR 3280 Manufactured Home Construction and Safety Standards*. Dealers will be informed that any new home in need of repair cannot be sold until all repairs have been corrected and certified as in compliance with the Federal Standards. The State Administrative Agency will keep records of serial number and label number of new homes in need of repairs which have been found on dealer lots containing code violations with the Federal Standard.

SP.15.7.2 Monitoring Repairs of Used Manufactured Homes - The State Administrative Agency will monitor repairs on used manufactured homes to insure all repairs are made and inspected for compliance with *Appendix C, Repair of Damaged Homes and Homes Sold for Salvage, State of North Carolina Regulations for Manufactured Homes, 2019 Edition*.

SP.15.7.3 Manufactured homes sold by dealers after they have been sold to the first purchaser may be inspected by local inspectors for alterations, additions, etc., for compliance with *Appendix C, Repair of Damaged Homes and Homes Sold for Salvage, State of North Carolina Regulations for Manufactured Homes, 2019 Edition*.