

## MEMO

**Date: October 27, 2023**

**To: Bridget Herring, Chair, NCBCC  
Jason Shepherd, Chair, Fire Committee**

**From: Charlie Johnson,  
Staff, Chief Fire Code Consultant**

**Re: GS 143-138(e) NC State Building Code  
Local Fire Prevention Regulations**

---

**Request is for approval to adopt the Brunswick County Fire Prevention Ordinance**

**The ordinance was approved by Brunswick County Board of Commissioners in October 2019 but was never submitted to the Building Code Council as required by GS 143-138 €**

Staff has reviewed the ordinance for the following statutory requirements and identified items that are:

1. More stringent than the adopted statewide fire prevention code, and
2. Which are found to regulate only activities and conditions in buildings, structures, and premises, and
3. That pose dangers of fire, explosion or related hazards, and
4. Are not matters in conflict with the State Building Code.

**Staff has reviewed and recommends approval of this ordinance.**

**§ 143-138. North Carolina State Building Code.**

(e) Effect upon Local Codes. - Except as otherwise provided in this section, the North Carolina State Building Code shall apply throughout the State, from the time of its adoption. Approved rules shall become effective in accordance with G.S. 150B-21.3. However, any political subdivision of the State may adopt a fire prevention code and floodplain management regulations within its jurisdiction. The territorial jurisdiction of any municipality or county for this purpose, unless otherwise specified by the General Assembly, shall be as follows: Municipal jurisdiction shall include all areas within the corporate limits of the municipality and extraterritorial jurisdiction areas established as provided in G.S. 160D-202 or a local act; county jurisdiction shall include all other areas of the county. No such code or regulations, other than floodplain management regulations and those permitted by G.S. 160D-1128, shall be effective until they have been officially approved by the Building Code Council as providing adequate minimum standards to preserve and protect health and safety, in accordance with the provisions of subsection (c)

above. Local floodplain regulations may regulate all types and uses of buildings or structures located in flood hazard areas identified by local, State, and federal agencies, and include provisions governing substantial improvements, substantial damage, cumulative substantial improvements, lowest floor elevation, protection of mechanical and electrical systems, foundation construction, anchorage, acceptable flood resistant materials, and other measures the political subdivision deems necessary considering the characteristics of its flood hazards and vulnerability. In the absence of approval by the Building Code Council, or in the event that approval is withdrawn, local fire prevention codes and regulations shall have no force and effect. Provided any local regulations approved by the local governing body which are found by the Council to be more stringent than the adopted statewide fire prevention code and which are found to regulate only activities and conditions in buildings, structures, and premises that pose dangers of fire, explosion or related hazards, and are not matters in conflict with the State Building Code, may be approved. Local governments may enforce the fire prevention code of the State Building Code using civil remedies authorized under G.S. 143-139, 153A-123, and 160A-175. If the Commissioner of Insurance or other State official with responsibility for enforcement of the Code institutes a civil action pursuant to G.S. 143-139, a local government may not institute a civil action under G.S. 143-139, 153A-123, or 160A-175 based upon the same violation. Appeals from the assessment or imposition of such civil remedies shall be as provided in G.S. 160D-1127.

A local government may not adopt any ordinance in conflict with the exemption provided by subsection (c1) of this section. No local ordinance or regulation shall be construed to limit the exemption provided by subsection (c1) of this section.



**Brunswick County Board of Commissioners**  
**ACTION AGENDA ITEM**  
**October 21, 2019**

**Action Item # ~~VII.-1.~~ IX-1**

**From:**  
Michael Slate, Director Code  
Administration

Code Administration - Brunswick County Fire Prevention  
Ordinance (Michael Slate-Director Code Administration)

**Issue/Action Requested:**

Request that the Board of Commissioners approve and adopt the Brunswick County Fire Prevention Ordinance.

**Background/Purpose of Request:**

Brunswick County is tasked with the duty to protect the safety and lives of its citizens. The intent of the Brunswick County Fire Prevention Ordinance is to prescribe regulations consistent with nationally-recognized good practices for the safeguarding, to a reasonable degree, of life and property, from hazards of fire and explosion arising from the storage, handling, and use of hazardous substances, materials and devices, from conditions hazardous to life and property in the use or occupancy of buildings or premises. Compliance with standards of the American Insurance Association or National Fire Protection Association or other approved nationally-recognized safety standards shall be deemed to be prima facie evidence of compliance with this intent. Nothing in these regulations is intended to limit or prescribe any authority derived from the North Carolina Fire Prevention Code or North Carolina General Statutes.

**Fiscal Impact:**

Reviewed By Director of Fiscal Operations

**Approved By County Attorney:**

Yes

**County Manager's Recommendation:**

Recommend that the Board of Commissioners approve and adopt the Brunswick County Fire Prevention Ordinance.

**ATTACHMENTS:**

Description

- Fire Prevention Ordinance-Word
- Fire Prevention Ordinance-PDF

# BRUNSWICK COUNTY FIRE PREVENTION ORDINANCE

## **Divisions**

Division 1. – Administration

Division 2. – Inspections Schedule for Existing Buildings

Division 3. – Permits, Plan Review, and Fees

Division 4. – Civil Penalties

Division 5. – Collection of Fees

Division 6. – Programs

Division 7. – Fire Prevention Specifications

## **Division 1. – Administration**

### Sec. 1. Title

These regulations shall be known and may be cited as the “Fire Prevention Code of Brunswick County” and referenced herein as the “code.”

### Sec. 2. Intent

The intent of this article is to prescribe regulations consistent with nationally-recognized good practices for the safeguarding, to a reasonable degree of life and property, from hazards of fire and explosion arising from the storage, handling, and use of hazardous substances, materials and devices, from conditions hazardous to life and property in the use or occupancy of buildings or premises. Compliance with standards of the American Insurance Association or National Fire Protection Association or other approved nationally-recognized safety standards shall be deemed to be prima facie evidence of compliance with this intent. Nothing in these regulations is intended to limit or prescribe any authority derived from the North Carolina Fire Prevention Code or North Carolina General Statutes.

### Sec. 3. Jurisdiction

This article is effective in unincorporated areas of Brunswick County. It is the responsibility of the Brunswick County Code Administration Department to issue all mandatory fire operational permits, fire construction permits, and, as adopted, optional fire operational permits, conduct all fire inspections for the County, and enforce the provisions of the North Carolina State Building Code: Fire Prevention Code, as adopted by the North Carolina Building Code Council and as amended. The North Carolina State Building Code: Fire Prevention Code is hereby adopted by reference as if fully set forth herein, to the extent such code is applicable for safe and stable design, methods of construction, minimum standards, and use of materials in building or structures hereafter erected, enlarged, altered, repaired, or otherwise constructed or reconstructed.

Amendments to the regulatory codes adopted by reference herein, which are from time to time adopted and published by the North Carolina Building Code Council referred to herein, shall be effective in the County at the time such amendments are filed with the County Chief Building Inspector or his or her designee. An official copy of the North Carolina Fire Prevention Code shall be kept within the Code Administration Department.

#### Sec. 4. Application of Article

- A. The provisions of this article shall apply equally to new and existing conditions, except that existing conditions not in strict compliance with the terms of this article shall be permitted to continue where the exceptions do not constitute a distinct hazard to life or property in the opinion of the Director of Code Administration or his or her acting agent.
- B. Nothing contained in this article shall be construed as applying to the transportation of any article or thing shipped under the jurisdiction of and in compliance with the regulations prescribed by the State Department of Transportation (DOT), nor as applying to the military forces of the United States.
- C. The North Carolina Fire Prevention Code definition of a residential occupancy is a multi-family building. It does not apply to one- and two-family dwellings.
- D. Foster Care Homes shall be operated by the Foster Care Parent in accordance with Chapter 131D of the North Carolina General Statutes and all North Carolina Division of Social Services guidelines and directions.

#### Sec. 5. Appointment and duties of Fire Code Official

- A. *Appointment of Fire Marshal.* The Board of Commissioners shall appoint the Fire Marshal or his or her designee to serve at the pleasure of the Board.
  - (1) Conducting fire prevention inspections of schools as required by Chapter 115C of the North Carolina General Statutes and of day care facilities as authorized by Chapter 110 of the North Carolina General Statutes;
  - (2) Conducting inspections of places of public gathering relative to fire protection and fire prevention;
  - (3) Administering this article.
- B. *Electrical Inspections.* Neither the fire code official nor his or her assistants shall make electrical inspections unless they are qualified to do so under NCGS § 153A-351.

#### Sec. 6. Inspection of buildings and premises

It shall be the duty of a fire code official to inspect, or cause to be inspected, all buildings and premises except the interiors of dwellings, as often as may be necessary, for the purpose of ascertaining and causing to be corrected any conditions liable to cause fire, endanger life from fire, or any violations of the provisions or intent of this article affecting the fire hazard.

## Sec. 7. Orders to eliminate dangerous or hazardous conditions

Whenever the fire code official shall find in any building or upon any premises dangerous or hazardous conditions, he or she shall order the dangerous conditions or materials to be removed or remedied.

If buildings or other premises are owned by one person and occupied by another under lease or otherwise, the orders issued in connection with the enforcing of this article shall apply to the occupants thereof, except where the rules or orders require the making of additions to or changes in the premises themselves, as such would immediately become real estate and be the property of the owner of the premises. In those cases, the rules or orders shall apply to the owner and not the occupant unless it is otherwise agreed between the owner and the occupant.

Dangerous or hazardous conditions include, but are not limited to, the following:

- A. Dangerous or unlawful amounts of combustible, explosive or otherwise hazardous materials;
- B. Hazardous conditions arising from defective or improperly installed equipment for handling or using combustible, explosive or otherwise hazardous materials;
- C. Dangerous accumulations of rubbish, waste paper, boxes, shavings or other highly combustible materials;
- D. Accumulations of dust or waste material in air conditioning or ventilation systems or of grease in kitchen or other exhaust ducts or inadequate clearances to unprotected combustible materials from hoods, grease extractors and ducts; or
- E. Obstructions to or on fire escapes, designated access openings in exterior walls for Fire Department use, stairs, passageways, doors or windows, liable to interfere with the operations of the Fire Department or egress of occupants in case of fire.

## Sec. 8. Service of orders

The service of orders for the correction of violations of this article shall be made upon the owner, occupant or other person responsible for the conditions in any manner allowed by law.

### **Division 2. Inspection Schedule for Existing Buildings**

#### Sec. 1. Fire Inspection and permit fees

Fire inspection and permit fees shall be as set by the Brunswick County Board of Commissioners.

#### Sec. 2. Frequency of Inspection

The minimum frequency of inspections for existing buildings shall be in accordance with the North Carolina State Building Code: Fire Prevention Code, as adopted by the North Carolina Building Code Council and as amended.

### **Division 3. Permits, Plan Review and Fees**

#### Sec. 1. Permits required

*Fire construction permit.* No person shall commence or proceed with the installation, extension, alteration or general repair of any fire protection system without obtaining a permit

from the fire code official. Permits do not apply to one- or two-family dwellings. A construction permit shall be obtained from the Brunswick County Code Administration Department in the following situations or activities:

105.7.1	Automatic fire-extinguishing Systems
105.7.2	Battery Systems (greater than 50 gallons)
105.7.3	Compressed Gases
105.7.4	Cryogenic Fluids
105.7.5	Fire Alarm and Detection Systems and Related equipment
105.7.6	Fire Pumps and Related Equipment
105.7.7	Flammable and Combustible Liquids
105.7.8	Hazardous Materials
105.7.9	Industrial Ovens
105.7.10	LP Gas Installation and modification (Applies only to occupancies covered by the NC Fire Prevention Code)
105.7.11	Private Fire Hydrants
105.7.12	Spraying and Dipping
105.7.13	Standpipe Systems with Sprinkler System
105.7.13	Standpipe Systems without a Sprinkler System
105.7.14	Temporary Membrane structures, tents, and canopies

*Operational Permit.* A mandatory operational permit shall be obtained for all existing and new buildings for the below situations or activities. All operation permit fees are included in the mandatory inspection fees. These permits do not apply to one- or two-family dwellings.

105.6.2	Amusement Buildings
105.6.4	Carnivals and fairs
105.6.6	Combustible dust-producing operations
105.6.9	Covered Malls, Buildings
105.6.13	Exhibits and trade shows
105.6.14	Explosives [Manufacturing, Storage, Handling, & Sale or use of explosives, fireworks, explosive material (60-day permit)]
105.6.16	Flammable and Combustible Liquids: Production, processing, transportation, storage, dispensed, used
105.6.16	Flammable and Combustible Liquids: Tank out of service (More than 90 days)
105.6.16	Flammable and Combustible Liquids: Install, alter, remove, or abandon flammable or combustible liquid tanks
105.6.16	Flammable and Combustible Liquids: Change the contents of a flammable or combustible liquid tank
105.6.16	Manufacture, process, blend, or refine flammable or combustible liquids
105.6.16	To engage in the dispensing of liquids fuels into the fuel tanks of motor vehicles at commercial, industrial, governmental or manufacturing establishments.

105.6.16	To utilize a site for the dispensing of liquid fuels from tank vehicles into the fuel tanks of motor vehicles at commercial, industrial, governmental, or manufacturing establishments
105.6.19	Fumigation and thermal insecticidal fogging
105.6.35	Private fire hydrants (Removal from service, use or operation)
105.6.36	Pyrotechnic special effect's materials
105.6.41	Spraying and dipping
105.6.43	Temporary Membrane structures, tents, and canopies

#### **Division 4. Civil Penalties**

##### **Sec. 1. Civil Penalties**

Any person who violates any of the provisions of the North Carolina State Building Code: Fire Prevention Code or the Fire Prevention Code of Brunswick County or who violates or fails to comply with any order made thereunder, or who shall build in violation of any detailed statement of specifications or plans submitted and approved thereunder, or any certificate or permit issued thereunder, shall be subject to penalties as listed in this article.

These penalties shall be recovered by the County in a civil action in the nature of a debt if the offender does not pay the penalties within a period of thirty (30) days after the issuance of the notice of violation. The notice of violation shall be in writing and served as allowed by law. Each day's continuing violation shall be a separate and distinct offense. Any action to recover such penalties may be joined in an action for appropriate equitable remedy, including injunctions and orders of abatement and including an action to recover damages by the County in abating, correcting, limiting, and otherwise dealing with the harmful effects of the offending action.

<b>Fire Code Reference</b>	<b>Violation Description</b>	<b>Penalty Amount</b>
Civil Penalties for non-compliant conditions or activities are as follows:		
105.3.5	Permit not posted or kept on premises	\$50.00
307.2	Unpermitted open burning (Immediate)	\$50.00
308.1.2	Careless use of ignited object (Immediate)	\$50.00
603.7	Use of non-approved heating appliance	\$50.00
703.1	Breach in fire wall/fire stops	\$50.00
703.2	Fire or exit door inoperative	\$100.00
703.2	Fire tower door open (Immediate)	\$100.00
703.2	Opening protectives not maintained per NFPA 80	\$50.00
310.3	"No Smoking" signs not posted where appropriate	\$50.00
310.2	Smoking in prohibited areas (Immediate)	\$100.00
901.4	Sprinkler or fire alarm inoperable	\$100.00
507.5.2	Fire hydrants not complying with code	\$50.00
903.1	Sprinkler system not complying with code	\$50.00
905.1	Standpipe system not complying with code	\$50.00
315.2.1	Sprinkler head(s) blocked/covered (Immediate)	\$50.00
505.1	Street address numbers not posted	\$50.00



505.1	Street address numbers not visible	\$50.00
901	Sprinkler/standpipe needs testing	\$100.00
901	Fire alarm system needs testing	\$100.00
1005.1	Storage in or on fire escape (Immediate)	\$100.00
1005.1	Blocked egress (Immediate)	\$100.00
1005.1	Locked exit doors (Immediate)	\$100.00
1005.1	Overcrowding (Immediate)	\$500.00
1003.6	Fire exit or aisle blocked (Immediate)	\$100.00
315.2.2	Storage in or on fire escape (Immediate)	\$100.00
1003.6	Exit or egress door needs repair	\$50.00
315.2.2	Blocked stairwells or stairways (Immediate)	\$100.00
1006.1	Exit illumination and marking	\$50.00
1011.1	Absence of required exit directional signs	\$50.00
404.2	Approved fire evacuation plan required	\$50.00
405.5	Fire drill performance not acceptable	\$50.00
405.2	No monthly fire drill reported	\$50.00
3405.3	Improper use of flammable liquids (Immediate)	\$100.00
3404.3.5	Flammable liquid not stored according to code	\$50.00
3405.2.5	Improper dispensing of flammable liquid (Immediate)	\$100.00
3404.4.3	Above-ground tanks not diked	\$50.00
2703.2.4	Tank installation not according to code	\$50.00
3404	Tank storage not according to code	\$50.00
1504.1	Spray painting in non-approved area	\$100.00
1504.1.2	Spray booth not complying to code	\$100.00
3003.5.3	Compressed gas cylinders not secured	\$50.00
105.1.2	No hazardous materials permit	\$50.00
2704	Chemical storage is not according to code	\$100.00
1004.3	Maximum occupancy not posted	\$50.00
308.1.4	Use of open flame cooking device	\$50.00
105.1.1	Failure to get tank work permit prior to work	\$200.00
105.2	Failure to obtain permits required by code	\$200.00
906.2	Portable fire extinguisher needing serving, tags, maintenance	\$50.00
904.4	Alternative Automatic Fire-Extinguishing Systems needs testing	\$100.00
112.1	All other violations of the code	\$50.00

*NOTE: The term "Immediate" as it appears above means that the fire code official may issue a citation immediately and the violation must be corrected by the violating party immediately.*

## **Division 5. Collection of Fees**

### **Sec. 1. Collection of fees**

- A. *Plan review fees.* Plan review fees shall be collected by Brunswick County Central Permitting prior to issuance of any building or fire permits.
- B. *Inspection fees (new construction).* In the event additional fees are required to be assessed during a construction project, any and all fees must be paid in full prior to the issuance of the certificate of occupancy. Occupying a building that has not been issued a certificate of occupancy will constitute a civil penalty for each day of the continued offense.
- C. *Inspection fees (existing buildings).* The fee for an inspection of an existing building shall be assessed and an invoice will be supplied to the owner, occupant, or designee. The responsible party will have thirty (30) days to remit payment. After thirty (30) days, the bill will be placed in a past due status and a second invoice will be sent to the responsible party. After a period of sixty (60) days of non-payment, the account will be subject to a ten percent (10%) late fee. The County will pursue legal action after a period of ninety (90) days of non-payment. Debts in excess of \$50.00 dollars that have been delinquent sixty (60) days or more will be recovered through the North Carolina Government Debt Setoff Clearinghouse in accordance with Chapter 105A of the North Carolina General Statutes, known as the “Setoff Debt Collection Act.”

## **Division 6. Programs**

### **Sec. 1. Rural Water Supply Sites Program**

- A. When a rural water supply point is used to meet minimum fire flow requirements, the project applicant or agent shall provide the following supporting documentation at the time of application to Brunswick County Code Administration:
  - (1) A completed North Carolina Office of the State Fire Marshal RRS agreement form to grant permission by the property owner to the fire department and mutual aid departments for all emergencies as deemed necessary by the fire chief officer or as approved by the fire code official.
  - (2) A completed North Carolina Office of the State Fire Marshal RSS verification of engineer form completed by a North Carolina licensed engineer or other approved designee by the fire code official.
- B. The water supply site shall have identification signage in accordance with the North Carolina DOT policy for erection of fire department water point location signs.
- C. Any approved water supply points shall have an approved dry hydrant installed in accordance with NFPA 1142 or other approved alternative equipment in place prior to bringing construction materials to the site.

Sec. 2. Knox Box Program

- A. The Knox Box Program provides fire departments within Brunswick County with a quick and easy means to access a secured building or area during an emergency. It also minimizes potential costly repairs caused by forcible entry and allows the building to be re-secured quickly and easily.
- B. The Knox Box program coordinator shall be the Brunswick County Code Administration Director or his or her designee. The Code Administration Director or his or her designee will review and authorize each order.
- C. For all new construction and existing remodel, renovation or upfit projects and/or where the fire hazard increases to a hazardous occupancy type, the requirement for a Knox Box will be determined by the fire code official in accordance with the North Carolina State Building Code: Fire Prevention Code.
- D. Knox Box Series and key sets should be as followed:

<b>Size of Building</b>	<b>Number of Key Sets</b>	<b>Model Knox Box</b>
1-2 Story	1 set of keys	3200 Series*
3-4 Stories	2 sets of keys	3200 Series*
5-8 Stories	3 sets of keys	4400 Series**
9 Stories and above	4 sets of keys	4400 Series**
Shopping Center less than 10 tenant spaces	1 set of keys	3200 Series*
Shopping Center more than 10 tenant spaces	2 sets of keys	4400 Series**

*\*Capacity less than 10 keys total. \*\*Capacity less than 50 keys total.*

- E. A Brunswick County Code Administration fire code official will assist the owner or operator with tagging and labeling individual keys. Keys should include, but are not limited to, a gate, main entrance, grand master, elevator control, mechanical room, fire alarm panel, sprinkler riser room, electrical room, and roof access.
- F. Knox boxes should be installed within ten (10) feet of the main entrance to a building at a height not to exceed five (5) feet above finished grade measured from the top of box. Other locations may be considered by the fire code official on a case-by-case basis.
- G. When the North Carolina State Building Code: Fire Prevention Code requires a group H hazardous occupancy operator to provide a Hazardous Materials Management Plan and/or Hazardous Materials Inventory Statement(s), said plans shall be provided by the facility operator on a flash drive that will be stored in an approved plastic bag or similar enclosure within the Knox Box for first responders. The facility operator shall notify the fire code official whenever there is a change or revision to the Hazardous Materials Plan and/or Hazardous Materials Inventory Statement so that current information is available to first responders.

- H. When a commercial occupant re-keys and/or replaces current lock cores or door hardware, it shall be the responsibility of the owner or operator to notify the fire code official and provide an updated key(s) to be placed in the fire department Knox Box on site.
- I. Knox Caps, Plugs, and Padlock Systems:
  - (1) A Knox Cap, Knox Plug, or Knox Padlock provides fire departments in Brunswick County with a means to protect fire sprinkler or fire standpipe systems fire department connections (FDCs) from tampering and malicious damage.
  - (2) A Knox Padlock provides fire departments in Brunswick County with a means to access a locked gate preventing damage associated with cutting padlocks or chains.
  - (3) Knox Caps and Knox Plugs are to be installed by a Brunswick County Code Administration fire code official on new construction and renovated fire sprinkler systems.

### Sec. 3. Fire Hydrants Storz Converter Program

- A. A Storz hydrant converter permanently converts a 4 ½” fire hydrant outlet from NST threads to a Storz connection. Set screws are on the collar of the Storz to ensure its permanent fixture to a fire hydrant. The conversion device reduces the typical connection time for emergency responders versus traditional threaded connections.
- B. A 5” Storz x 4 ½ F NST conversion kit will be required on all new fire hydrants and existing fire hydrants having NST threads within 1,000 feet (via a fire department hose lay method) of new commercial buildings and multi-family buildings occupancies and additions, change of use, or renovations to existing commercial occupancy buildings.

### Sec. 4. Fire Department Connections (FDC) for Fire Sprinkler Systems and Standpipe System Program

- A. Fire Department Connections are used for fire sprinkler systems and fire standpipe systems utilized to connect fire hoses to either maintain pressure where a building is equipped with a fire sprinkler system or to supply water to remote fire standpipe systems utilized by firefighters to connect prepared fire hoses for suppression efforts for fire ground operations.
  - (1) When a Fire Department Connection is required by the North Carolina State Building Code: Fire Prevention Code for a fire sprinkler system or standpipe system, the FDCs shall be of compatible size and type for local responding fire apparatus as indicated by the local fire district Fire Chief to the fire code official with Brunswick County Code Administration.
  - (2) When a Fire Department Connection is required by the North Carolina State Building Code: Fire Prevention Code for a fire sprinkler system or standpipe system, the FDCs shall be located within a maximum of 50’ feet from a fire hydrant.

## Sec. 5. Fireworks, Blasting, and Pyrotechnic Events Program

- A. Fireworks classified as 1.3G are explosives classified as display fireworks. These explosives require an active display operator license issued by the Office of the State Fire Marshal (OSFM), North Carolina Department of Insurance (NCDOI), pursuant to NCGS § 14-410.
- (1) An application for an explosives, blasting, or pyrotechnic event shall be submitted to Brunswick County Code Administration a minimum of three (3) weeks prior to the event to allow adequate time to complete a fire plan review and pre-site inspection, to include, but not limited to, the discharge site, spectator viewing, parking, and fallout areas prior to the fire code official issuing or denying a mandatory explosives permit.
  - (2) A post-display inspection and accounting for unexploded devices is required by the NCDOI licensed operator and must be witnessed by the fire code official. All mortars shall be painted orange, red, or similar color approved by the fire code official. The intent is to readily identify a “dud” mortar that failed to explode during a display show within the fallout area.
  - (3) A pre-display inspection where fireworks are placed on a barge. Once in position, the distance should be verified by a Brunswick County Sheriff’s Office radar device or other approved calibrated measuring device by the fire code official related to the pre-approved fallout zone site plan.

## Division 7. Fire Prevention Specifications

In addition to the current edition of the North Carolina State Building Code: Fire Prevention Code as adopted by the North Carolina Building Code Council and as amended, portions of Appendices B, C, and D are adopted as shown herein:

### Appendix B “Fire Flow Requirements For Buildings”

#### Section B101.1 General

B101.1 *Scope*. The procedure for determining fire-flow requirements for buildings or portions of buildings hereafter constructed shall be in accordance with this appendix. This appendix does not apply to structures other than buildings.

#### Section B102.1 Definitions

B102.1 *Definitions*. For the purpose of this appendix, certain terms are defined as follows:

**FIRE-FLOW**. The flow rate of a water supply, measured at 20 pounds per square inch (psi) (138 kPa) residual pressure, that is available for firefighting.

**FIRE-FLOW CALCULATION AREA**. The floor area, in square feet (m<sup>2</sup>), used to determine the required fire flow.

#### Section B103 Modifications

B103.1 *Decreases*. The fire chief is authorized to reduce the fire-flow requirements for isolated buildings or a group of buildings in rural areas or small communities where the development of full fire-flow requirements is impractical.

B103.2 *Increases*. The fire chief is authorized to increase the fire-flow requirements where conditions indicate an unusual susceptibility to group fires or conflagrations. An increase shall not be more than twice that required for the building under consideration.

B103.3 *Areas without water supply systems*. For information regarding water supplies for fire-fighting purposes in rural and suburban areas in which adequate and reliable water supply systems do not exist, the fire code official is authorized to utilize NFPA 1142 or the International Wildland-Urban Interface Code.

#### Section B104 Fire-Flow Calculation Area

B104.1 *General*. The fire-flow calculation area shall be the total floor area of all floor levels within the exterior walls, and under the horizontal projections of the roof of a building, except as modified in Section B104.3.

B104.2 *Area separation*. Portions of buildings which are separated by fire walls without openings, constructed in accordance with the International Building Code, are allowed to be considered as separate fire-flow calculation areas.

B104.3 *Type IA and Type IB construction*. The fire-flow calculation area of buildings constructed of Type IA and Type IB construction shall be the area of the three largest successive floors. Exception: Fire-flow calculation area for open parking garages shall be determined by the area of the largest floor.

#### Section B105 Fire-Flow Requirements For Buildings

B105.1 *One- and two-family dwellings*. The minimum fire-flow and flow duration requirements for one- and two-family dwellings having a fire-flow calculation area that does not exceed 3,600 square feet (344.5 m<sup>2</sup>) shall be 1,000 gallons per minute (3785.4 L/min) for 1 hour. Fire-flow and flow duration for dwellings having a fire-flow calculation area in excess of 3,600 square feet (344.5m<sup>2</sup>) shall not be less than that specified in Table B105.1. Exception: A reduction in required fire-flow of 50 percent, as approved, is allowed when the building is equipped with an approved automatic sprinkler system.

B105.2 *Buildings other than one- and two-family dwellings*. The minimum fire-flow and flow duration for buildings other than one- and two-family dwellings shall be as specified in Table B105.1. Exception: A reduction in required fire-flow of up to 75 percent, as approved, is allowed when the building is provided with an approved automatic sprinkler system installed in accordance with Section 903.3.1.1 or 903.3.1.2. The resulting fire-flow shall not be less than 1,500 gallons per minute (5678 L/min) for the prescribed duration as specified in Table B105.1

**A. TABLE B105.1 MINIMUM REQUIRED FIRE-FLOW AND FLOW DURATION FOR BUILDINGS**

FIRE-FLOW CALCULATION AREA (square feet)					FIRE-FLOW (gallons per minute) <sup>b</sup>	FLOW DURATION (hours)
Type IA and IB <sup>a</sup>	Type IIA and IIIA <sup>a</sup>	Type IV and V-A <sup>a</sup>	Type IIB and IIIB <sup>a</sup>	Type V-B <sup>a</sup>		
0-22,700	0-12,700	0-8,200	0-5,900	0-3,600	1,500	2
22,701-30,200	12,701-17,000	8,201-10,900	5,901-7,900	3,601-4,800	1,750	
30,201-38,700	17,001-21,800	10,901-12,900	7,901-9,800	4,801-6,200	2,000	
38,701-48,300	21,801-24,200	12,901-17,400	9,801-12,600	6,201-7,700	2,250	
48,301-59,000	24,201-33,200	17,401-21,300	12,601-15,400	7,701-9,400	2,500	
59,001-70,900	33,201-39,700	21,301-25,500	15,401-18,400	9,401-11,300	2,750	
70,901-83,700	39,701-47,100	25,501-30,100	18,401-21,800	11,301-13,400	3,000	3
83,701-97,700	47,101-54,900	30,101-35,200	21,801-25,900	13,401-15,600	3,250	
97,701-112,700	54,901-63,400	35,201-40,600	25,901-29,300	15,601-18,000	3,500	
112,701-128,700	63,401-72,400	40,601-46,400	29,301-33,500	18,001-20,600	3,750	
128,701-145,900	72,401-82,100	46,401-52,500	33,501-37,900	20,601-23,300	4,000	4
145,901-164,200	82,101-92,400	52,501-59,100	37,901-42,700	23,301-26,300	4,250	
164,201-183,400	92,401-103,100	59,101-66,000	42,701-47,700	26,301-29,300	4,500	
183,401-203,700	103,101-114,600	66,001-73,300	47,701-53,000	29,301-32,600	4,750	
203,701-225,200	114,601-126,700	73,301-81,100	53,001-58,600	32,601-36,000	5,000	
225,201-247,700	126,701-139,400	81,101-89,200	58,601-65,400	36,001-39,600	5,250	
247,701-271,200	139,401-152,600	89,201-97,700	65,401-70,600	39,601-43,400	5,500	
271,201-295,900	152,601-166,500	97,701-106,500	70,601-77,000	43,401-47,400	5,750	
295,901-Greater	166,501-Greater	106,501-115,800	77,001-83,700	47,401-51,500	6,000	
—	—	115,801-125,500	83,701-90,600	51,501-55,700	6,250	
—	—	125,501-135,500	90,601-97,900	55,701-60,200	6,500	
—	—	135,501-145,800	97,901-106,800	60,201-64,800	6,750	
—	—	145,801-156,700	106,801-113,200	64,801-69,600	7,000	
—	—	156,701-167,900	113,201-121,300	69,601-74,600	7,250	
—	—	167,901-179,400	121,301-129,600	74,601-79,800	7,500	
—	—	179,401-191,400	129,601-138,300	79,801-85,100	7,750	
—	—	191,401-Greater	138,301-Greater	85,101-Greater	8,000	

For SI: 1 square foot = 0.0929 m<sup>2</sup>, 1 gallon per minute = 3.785 L/m, 1 pound per square inch = 6.895 kPa.

<sup>a</sup>Types of construction are based on the *International Building Code*.

Measured at 20 psi residual pressure.

<sup>b</sup>Or as approved by the fire code official.

## Appendix C Fire Hydrant Locations and Distribution

### Section C101 General

C101.1 *Scope*. Fire hydrants shall be provided in accordance with this appendix for the protection of buildings, or portions of buildings, hereafter constructed.

### Section C102 Location

C102.1 *Fire hydrant locations*. Fire hydrants shall be provided along required fire apparatus access roads and adjacent public streets.

### Section C103 Number of Fire Hydrants

C103.1 *Fire hydrants available*. The minimum number of fire hydrants available to a building shall not be less than that listed in Table C105.1. The number of fire hydrants available to a complex or subdivision shall not be less than that determined by spacing requirements listed in Table C105.1 when applied to fire apparatus access roads and perimeter public streets from which fire operations could be conducted.

### Section C104 Consideration of Existing Fire Hydrants

C104.1 *Existing fire hydrants*. Existing fire hydrants on public streets are allowed to be considered as available. Existing fire hydrants on adjacent properties shall not be considered available unless fire apparatus access roads extend between properties and easements are established to prevent obstruction of such roads.

### Section C105 Distribution of Fire Hydrants

C105.1 *Hydrant spacing*. The average spacing between fire hydrants shall not exceed that listed in Table C105.1. Exception: The fire chief is authorized to accept a deficiency of up to 10 percent where existing fire hydrants provide all or a portion of the required fire hydrant service. Regardless of the average spacing, fire hydrants shall be located such that all points on streets and access roads adjacent to a building are within the distances listed in Table C105.1. or as approved by the fire code official.

#### A. Table C105.1 Number and Distribution of Fire Hydrants

**TABLE C105.1  
NUMBER AND DISTRIBUTION OF FIRE HYDRANTS**

<b>FIRE-FLOW REQUIREMENT (gpm)</b>	<b>MINIMUM NUMBER OF HYDRANTS</b>	<b>AVERAGE SPACING BETWEEN HYDRANTS<sup>a, b, c</sup> (feet)</b>	<b>MAXIMUM DISTANCE FROM ANY POINT ON STREET OR ROAD FRONTAGE TO A HYDRANT<sup>d</sup></b>
1,750 or less	1	500	250
2,000-2,250	2	450	225
2,500	3	450	225
3,000	3	400	225



3,500-4,000	4	350	210
4,500-5,000	5	300	180
5,500	6	300	180
6,000	6	250	150
6,500-7,000	7	250	150
7,500 or more	8 or more <sup>e</sup>	200	120

For SI: 1 foot = 304.8 mm, 1 gallon per minute = 3.785 L/m.

<sup>a</sup>Reduce by 100 feet for dead-end streets or roads.

<sup>b</sup>Where streets are provided with median dividers which cannot be crossed by fire fighters pulling hose lines, or where arterial streets are provided with four or more traffic lanes and have a traffic count of more than 30,000 vehicles per day, hydrant spacing shall average 500 feet on each side of the street and be arranged on an alternating basis up to a fire-flow requirement of 7,000 gallons per minute and 400 feet for higher fire-flow requirements.

<sup>c</sup>Where new water mains are extended along streets where hydrants are not needed for protection of structures or similar fire problems, fire hydrants shall be provided at spacing not to exceed 1,000 feet to provide for transportation hazards.

<sup>d</sup>Reduce by 50 feet for dead-end streets or roads.

<sup>e</sup>One hydrant for each 1,000 gallons per minute or fraction thereof.

## Appendix D Fire Apparatus Access Roads

### Section D101 General

D101.1 *Scope*. Fire apparatus access roads shall be in accordance with this appendix and all other applicable requirements of the *International Fire Code*.

### Section D102 Required Access

D102.1 *Access and loading*. Facilities, buildings or portions of buildings hereafter constructed shall be accessible to fire department apparatus by way of an approved fire apparatus access road with an asphalt, concrete or other approved driving surface capable of supporting the imposed load of fire apparatus weighing at least 75,000 pounds (34 050 kg).

### Section D103 Minimum Specifications

D103.3 *Turning radius*. The minimum turning radius shall be determined by the fire code official.

D103.4 *Dead ends*. Dead-end fire apparatus access roads in excess of 150 feet (45 720 mm) shall be provided with width and turnaround provisions in accordance with Table D103.4.

**TABLE D103.4 REQUIREMENTS FOR DEAD-END FIRE APPARATUS ACCESS ROADS**

LENGTH (feet)	WIDTH (feet)	TURNAROUNDS REQUIRED
0–150	20	None required
151–500	20	120-foot Hammerhead, 60-foot “Y” or 96-foot-diameter cul-de-sac in accordance with Figure D103.1
501–750	26	120-foot Hammerhead, 60-foot “Y” or 96-foot-diameter cul-de-sac in accordance with Figure D103.1
Over 750		Special approval required

For SI: 1 foot = 304.8 mm.

**FIGURE D103.1  
DEAD-END FIRE APPARATUS ACCESS ROAD  
TURNAROUND**

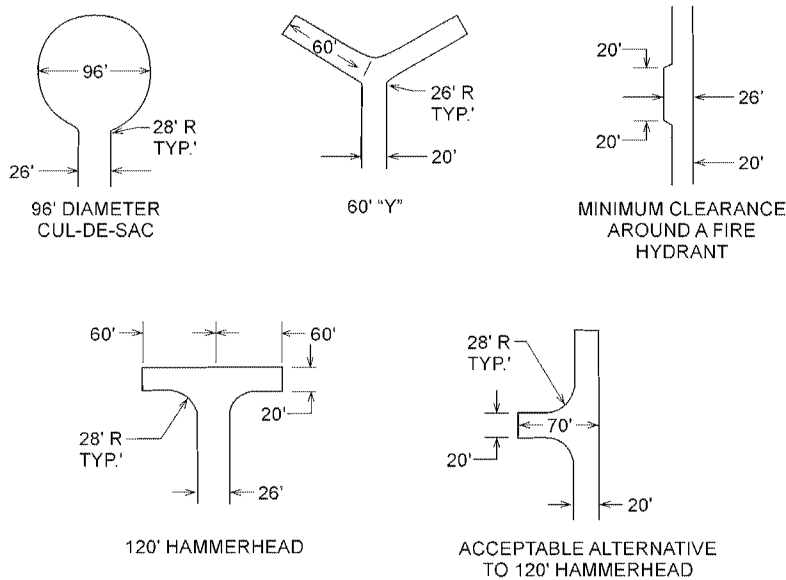

D103.5 *Fire apparatus access road gates.* Gates securing the fire apparatus access roads shall comply with all of the following criteria:

- A. The minimum gate width shall be 20 feet (6096 mm).
- B. Gates shall be of the swinging or sliding type.
- C. Construction of gates shall be of materials that allow manual operation by one *person*.

- D. Gate components shall be maintained in an operative condition at all times and replaced or repaired when defective.
- E. Electric gates shall be equipped with a means of opening the gate by fire department personnel for emergency access. Emergency opening devices shall be *approved* by the *fire code official*.
- F. Manual opening gates shall not be locked with a padlock or chain and padlock unless they are capable of being opened by means of forcible entry tools or when a key box containing the key(s) to the lock is installed at the gate location.
- G. Locking device specifications shall be submitted for approval by the *fire code official*.
- H. Electric gate operators, where provided, shall be *listed* in accordance with UL 325.
- I. Gates intended for automatic operation shall be designed, constructed and installed to comply with the requirements of ASTM F 2200.

D103.6 *Signs*. Where required by the *fire code official* fire apparatus fire lanes shall be marked with permanent NO PARKING—FIRE LANE marking affixed to the pavement and/or face of curbing shall meet the Brunswick County Fire Lane Marking Specification or as approved by the fire code official.

#### Section D104 Commercial and Industrial Developments

D104.1 Commercial and Multi-Family Structures exceeding 30 feet or three stories in height shall provide at least two means of fire apparatus access.

D104.2 Commercial Structures having a gross enclosed floor area of over 62,000 square feet shall be provided with two separate and approved fire apparatus access roads. However, when equipped throughout with an approved automatic sprinkler system, projects may be allowed to have a gross floor area of up to 124,000 square feet and provide access through one approved access road.

#### Section D105 Fire Department Aerial Apparatus Access Roads

Where fire department aerial apparatus access roads are required in accordance with North Carolina State Building Code: Fire Prevention Code, roads shall meet the Brunswick County aerial apparatus turning radius specification.

D105.1 *Where required*. Commercial and Multi-Family Structures or portions of structures exceeding 30 feet in height above the lowest level of fire department vehicle access shall be provided with approved fire apparatus access roads capable of accommodating fire department aerial apparatus. Overhead utility and power lines shall not be located within the aerial fire apparatus access roadway.

D105.2 *Width*. Fire apparatus access roads shall have a minimum unobstructed width of 26 feet in the immediate vicinity of any building or portion of a commercial or multi-family building more than 30 feet in height.

D105.3 *Proximity to building*. At least one of the required access routes shall be located at least 15 feet, but no more than 30 feet from the structure and shall be parallel to one entire side of the building.

# BRUNSWICK COUNTY FIRE PREVENTION ORDINANCE

## **Divisions**

Division 1. – Administration

Division 2. – Inspections Schedule for Existing Buildings

Division 3. – Permits, Plan Review, and Fees

Division 4. – Civil Penalties

Division 5. – Collection of Fees

Division 6. – Programs

Division 7. – Fire Prevention Specifications

## **Division 1. – Administration**

### Sec. 1. Title

These regulations shall be known and may be cited as the “Fire Prevention Code of Brunswick County” and referenced herein as the “code.”

### Sec. 2. Intent

The intent of this article is to prescribe regulations consistent with nationally-recognized good practices for the safeguarding, to a reasonable degree of life and property, from hazards of fire and explosion arising from the storage, handling, and use of hazardous substances, materials and devices, from conditions hazardous to life and property in the use or occupancy of buildings or premises. Compliance with standards of the American Insurance Association or National Fire Protection Association or other approved nationally-recognized safety standards shall be deemed to be prima facie evidence of compliance with this intent. Nothing in these regulations is intended to limit or prescribe any authority derived from the North Carolina Fire Prevention Code or North Carolina General Statutes.

### Sec. 3. Jurisdiction

This article is effective in unincorporated areas of Brunswick County. It is the responsibility of the Brunswick County Code Administration Department to issue all mandatory fire operational permits, fire construction permits, and, as adopted, optional fire operational permits, conduct all fire inspections for the County, and enforce the provisions of the North Carolina State Building Code: Fire Prevention Code, as adopted by the North Carolina Building Code Council and as amended. The North Carolina State Building Code: Fire Prevention Code is hereby adopted by reference as if fully set forth herein, to the extent such code is applicable for safe and stable design, methods of construction, minimum standards, and use of materials in building or structures hereafter erected, enlarged, altered, repaired, or otherwise constructed or reconstructed.

Amendments to the regulatory codes adopted by reference herein, which are from time to time adopted and published by the North Carolina Building Code Council referred to herein, shall be effective in the County at the time such amendments are filed with the County Chief Building Inspector or his or her designee. An official copy of the North Carolina Fire Prevention Code shall be kept within the Code Administration Department.

#### Sec. 4. Application of Article

- A. The provisions of this article shall apply equally to new and existing conditions, except that existing conditions not in strict compliance with the terms of this article shall be permitted to continue where the exceptions do not constitute a distinct hazard to life or property in the opinion of the Director of Code Administration or his or her acting agent.
- B. Nothing contained in this article shall be construed as applying to the transportation of any article or thing shipped under the jurisdiction of and in compliance with the regulations prescribed by the State Department of Transportation (DOT), nor as applying to the military forces of the United States.
- C. The North Carolina Fire Prevention Code definition of a residential occupancy is a multi-family building. It does not apply to one- and two-family dwellings.
- D. Foster Care Homes shall be operated by the Foster Care Parent in accordance with Chapter 131D of the North Carolina General Statutes and all North Carolina Division of Social Services guidelines and directions.

#### Sec. 5. Appointment and duties of Fire Code Official

- A. *Appointment of Fire Marshal.* The Board of Commissioners shall appoint the Fire Marshal or his or her designee to serve at the pleasure of the Board.
  - (1) Conducting fire prevention inspections of schools as required by Chapter 115C of the North Carolina General Statutes and of day care facilities as authorized by Chapter 110 of the North Carolina General Statutes;
  - (2) Conducting inspections of places of public gathering relative to fire protection and fire prevention;
  - (3) Administering this article.
- B. *Electrical Inspections.* Neither the fire code official nor his or her assistants shall make electrical inspections unless they are qualified to do so under NCGS § 153A-351.

#### Sec. 6. Inspection of buildings and premises

It shall be the duty of a fire code official to inspect, or cause to be inspected, all buildings and premises except the interiors of dwellings, as often as may be necessary, for the purpose of ascertaining and causing to be corrected any conditions liable to cause fire, endanger life from fire, or any violations of the provisions or intent of this article affecting the fire hazard.

## Sec. 7. Orders to eliminate dangerous or hazardous conditions

Whenever the fire code official shall find in any building or upon any premises dangerous or hazardous conditions, he or she shall order the dangerous conditions or materials to be removed or remedied.

If buildings or other premises are owned by one person and occupied by another under lease or otherwise, the orders issued in connection with the enforcing of this article shall apply to the occupants thereof, except where the rules or orders require the making of additions to or changes in the premises themselves, as such would immediately become real estate and be the property of the owner of the premises. In those cases, the rules or orders shall apply to the owner and not the occupant unless it is otherwise agreed between the owner and the occupant.

Dangerous or hazardous conditions include, but are not limited to, the following:

- A. Dangerous or unlawful amounts of combustible, explosive or otherwise hazardous materials;
- B. Hazardous conditions arising from defective or improperly installed equipment for handling or using combustible, explosive or otherwise hazardous materials;
- C. Dangerous accumulations of rubbish, waste paper, boxes, shavings or other highly combustible materials;
- D. Accumulations of dust or waste material in air conditioning or ventilation systems or of grease in kitchen or other exhaust ducts or inadequate clearances to unprotected combustible materials from hoods, grease extractors and ducts; or
- E. Obstructions to or on fire escapes, designated access openings in exterior walls for Fire Department use, stairs, passageways, doors or windows, liable to interfere with the operations of the Fire Department or egress of occupants in case of fire.

## Sec. 8. Service of orders

The service of orders for the correction of violations of this article shall be made upon the owner, occupant or other person responsible for the conditions in any manner allowed by law.

### **Division 2. Inspection Schedule for Existing Buildings**

#### Sec. 1. Fire Inspection and permit fees

Fire inspection and permit fees shall be as set by the Brunswick County Board of Commissioners.

#### Sec. 2. Frequency of Inspection

The minimum frequency of inspections for existing buildings shall be in accordance with the North Carolina State Building Code: Fire Prevention Code, as adopted by the North Carolina Building Code Council and as amended.

### **Division 3. Permits, Plan Review and Fees**

#### Sec. 1. Permits required

*Fire construction permit.* No person shall commence or proceed with the installation, extension, alteration or general repair of any fire protection system without obtaining a permit

from the fire code official. Permits do not apply to one- or two-family dwellings. A construction permit shall be obtained from the Brunswick County Code Administration Department in the following situations or activities:

105.7.1	Automatic fire-extinguishing Systems
105.7.2	Battery Systems (greater than 50 gallons)
105.7.3	Compressed Gases
105.7.4	Cryogenic Fluids
105.7.5	Fire Alarm and Detection Systems and Related equipment
105.7.6	Fire Pumps and Related Equipment
105.7.7	Flammable and Combustible Liquids
105.7.8	Hazardous Materials
105.7.9	Industrial Ovens
105.7.10	LP Gas Installation and modification (Applies only to occupancies covered by the NC Fire Prevention Code)
105.7.11	Private Fire Hydrants
105.7.12	Spraying and Dipping
105.7.13	Standpipe Systems with Sprinkler System
105.7.13	Standpipe Systems without a Sprinkler System
105.7.14	Temporary Membrane structures, tents, and canopies

*Operational Permit.* A mandatory operational permit shall be obtained for all existing and new buildings for the below situations or activities. All operation permit fees are included in the mandatory inspection fees. These permits do not apply to one- or two-family dwellings.

105.6.2	Amusement Buildings
105.6.4	Carnivals and fairs
105.6.6	Combustible dust-producing operations
105.6.9	Covered Malls, Buildings
105.6.13	Exhibits and trade shows
105.6.14	Explosives [Manufacturing, Storage, Handling, & Sale or use of explosives, fireworks, explosive material (60-day permit)]
105.6.16	Flammable and Combustible Liquids: Production, processing, transportation, storage, dispensed, used
105.6.16	Flammable and Combustible Liquids: Tank out of service (More than 90 days)
105.6.16	Flammable and Combustible Liquids: Install, alter, remove, or abandon flammable or combustible liquid tanks
105.6.16	Flammable and Combustible Liquids: Change the contents of a flammable or combustible liquid tank
105.6.16	Manufacture, process, blend, or refine flammable or combustible liquids
105.6.16	To engage in the dispensing of liquids fuels into the fuel tanks of motor vehicles at commercial, industrial, governmental or manufacturing establishments.

105.6.16	To utilize a site for the dispensing of liquid fuels from tank vehicles into the fuel tanks of motor vehicles at commercial, industrial, governmental, or manufacturing establishments
105.6.19	Fumigation and thermal insecticidal fogging
105.6.35	Private fire hydrants (Removal from service, use or operation)
105.6.36	Pyrotechnic special effect's materials
105.6.41	Spraying and dipping
105.6.43	Temporary Membrane structures, tents, and canopies

#### Division 4. Civil Penalties

##### Sec. 1. Civil Penalties

Any person who violates any of the provisions of the North Carolina State Building Code: Fire Prevention Code or the Fire Prevention Code of Brunswick County or who violates or fails to comply with any order made thereunder, or who shall build in violation of any detailed statement of specifications or plans submitted and approved thereunder, or any certificate or permit issued thereunder, shall be subject to penalties as listed in this article.

These penalties shall be recovered by the County in a civil action in the nature of a debt if the offender does not pay the penalties within a period of thirty (30) days after the issuance of the notice of violation. The notice of violation shall be in writing and served as allowed by law. Each day's continuing violation shall be a separate and distinct offense. Any action to recover such penalties may be joined in an action for appropriate equitable remedy, including injunctions and orders of abatement and including an action to recover damages by the County in abating, correcting, limiting, and otherwise dealing with the harmful effects of the offending action.

Fire Code Reference	Violation Description	Penalty Amount
Civil Penalties for non-compliant conditions or activities are as follows:		
105.3.5	Permit not posted or kept on premises	\$50.00
307.2	Unpermitted open burning (Immediate)	\$50.00
308.1.2	Careless use of ignited object (Immediate)	\$50.00
603.7	Use of non-approved heating appliance	\$50.00
703.1	Breach in fire wall/fire stops	\$50.00
703.2	Fire or exit door inoperative	\$100.00
703.2	Fire tower door open (Immediate)	\$100.00
703.2	Opening protectives not maintained per NFPA 80	\$50.00
310.3	"No Smoking" signs not posted where appropriate	\$50.00
310.2	Smoking in prohibited areas (Immediate)	\$100.00
901.4	Sprinkler or fire alarm inoperable	\$100.00
507.5.2	Fire hydrants not complying with code	\$50.00
903.1	Sprinkler system not complying with code	\$50.00
905.1	Standpipe system not complying with code	\$50.00
315.2.1	Sprinkler head(s) blocked/covered (Immediate)	\$50.00
505.1	Street address numbers not posted	\$50.00



505.1	Street address numbers not visible	\$50.00
901	Sprinkler/standpipe needs testing	\$100.00
901	Fire alarm system needs testing	\$100.00
1005.1	Storage in or on fire escape (Immediate)	\$100.00
1005.1	Blocked egress (Immediate)	\$100.00
1005.1	Locked exit doors (Immediate)	\$100.00
1005.1	Overcrowding (Immediate)	\$500.00
1003.6	Fire exit or aisle blocked (Immediate)	\$100.00
315.2.2	Storage in or on fire escape (Immediate)	\$100.00
1003.6	Exit or egress door needs repair	\$50.00
315.2.2	Blocked stairwells or stairways (Immediate)	\$100.00
1006.1	Exit illumination and marking	\$50.00
1011.1	Absence of required exit directional signs	\$50.00
404.2	Approved fire evacuation plan required	\$50.00
405.5	Fire drill performance not acceptable	\$50.00
405.2	No monthly fire drill reported	\$50.00
3405.3	Improper use of flammable liquids (Immediate)	\$100.00
3404.3.5	Flammable liquid not stored according to code	\$50.00
3405.2.5	Improper dispensing of flammable liquid (Immediate)	\$100.00
3404.4.3	Above-ground tanks not diked	\$50.00
2703.2.4	Tank installation not according to code	\$50.00
3404	Tank storage not according to code	\$50.00
1504.1	Spray painting in non-approved area	\$100.00
1504.1.2	Spray booth not complying to code	\$100.00
3003.5.3	Compressed gas cylinders not secured	\$50.00
105.1.2	No hazardous materials permit	\$50.00
2704	Chemical storage is not according to code	\$100.00
1004.3	Maximum occupancy not posted	\$50.00
308.1.4	Use of open flame cooking device	\$50.00
105.1.1	Failure to get tank work permit prior to work	\$200.00
105.2	Failure to obtain permits required by code	\$200.00
906.2	Portable fire extinguisher needing serving, tags, maintenance	\$50.00
904.4	Alternative Automatic Fire-Extinguishing Systems needs testing	\$100.00
112.1	All other violations of the code	\$50.00

*NOTE: The term "Immediate" as it appears above means that the fire code official may issue a citation immediately and the violation must be corrected by the violating party immediately.*

## **Division 5. Collection of Fees**

### **Sec. 1. Collection of fees**

- A. *Plan review fees.* Plan review fees shall be collected by Brunswick County Central Permitting prior to issuance of any building or fire permits.
- B. *Inspection fees (new construction).* In the event additional fees are required to be assessed during a construction project, any and all fees must be paid in full prior to the issuance of the certificate of occupancy. Occupying a building that has not been issued a certificate of occupancy will constitute a civil penalty for each day of the continued offense.
- C. *Inspection fees (existing buildings).* The fee for an inspection of an existing building shall be assessed and an invoice will be supplied to the owner, occupant, or designee. The responsible party will have thirty (30) days to remit payment. After thirty (30) days, the bill will be placed in a past due status and a second invoice will be sent to the responsible party. After a period of sixty (60) days of non-payment, the account will be subject to a ten percent (10%) late fee. The County will pursue legal action after a period of ninety (90) days of non-payment. Debts in excess of \$50.00 dollars that have been delinquent sixty (60) days or more will be recovered through the North Carolina Government Debt Setoff Clearinghouse in accordance with Chapter 105A of the North Carolina General Statutes, known as the "Setoff Debt Collection Act."

## **Division 6. Programs**

### **Sec. 1. Rural Water Supply Sites Program**

- A. When a rural water supply point is used to meet minimum fire flow requirements, the project applicant or agent shall provide the following supporting documentation at the time of application to Brunswick County Code Administration:
  - (1) A completed North Carolina Office of the State Fire Marshal RRS agreement form to grant permission by the property owner to the fire department and mutual aid departments for all emergencies as deemed necessary by the fire chief officer or as approved by the fire code official.
  - (2) A completed North Carolina Office of the State Fire Marshal RSS verification of engineer form completed by a North Carolina licensed engineer or other approved designee by the fire code official.
- B. The water supply site shall have identification signage in accordance with the North Carolina DOT policy for erection of fire department water point location signs.
- C. Any approved water supply points shall have an approved dry hydrant installed in accordance with NFPA 1142 or other approved alternative equipment in place prior to bringing construction materials to the site.

Sec. 2. Knox Box Program

- A. The Knox Box Program provides fire departments within Brunswick County with a quick and easy means to access a secured building or area during an emergency. It also minimizes potential costly repairs caused by forcible entry and allows the building to be re-secured quickly and easily.
- B. The Knox Box program coordinator shall be the Brunswick County Code Administration Director or his or her designee. The Code Administration Director or his or her designee will review and authorize each order.
- C. For all new construction and existing remodel, renovation or upfit projects and/or where the fire hazard increases to a hazardous occupancy type, the requirement for a Knox Box will be determined by the fire code official in accordance with the North Carolina State Building Code: Fire Prevention Code.
- D. Knox Box Series and key sets should be as followed:

<b>Size of Building</b>	<b>Number of Key Sets</b>	<b>Model Knox Box</b>
1-2 Story	1 set of keys	3200 Series*
3-4 Stories	2 sets of keys	3200 Series*
5-8 Stories	3 sets of keys	4400 Series**
9 Stories and above	4 sets of keys	4400 Series**
Shopping Center less than 10 tenant spaces	1 set of keys	3200 Series*
Shopping Center more than 10 tenant spaces	2 sets of keys	4400 Series**

*\*Capacity less than 10 keys total. \*\*Capacity less than 50 keys total.*

- E. A Brunswick County Code Administration fire code official will assist the owner or operator with tagging and labeling individual keys. Keys should include, but are not limited to, a gate, main entrance, grand master, elevator control, mechanical room, fire alarm panel, sprinkler riser room, electrical room, and roof access.
- F. Knox boxes should be installed within ten (10) feet of the main entrance to a building at a height not to exceed five (5) feet above finished grade measured from the top of box. Other locations may be considered by the fire code official on a case-by-case basis.
- G. When the North Carolina State Building Code: Fire Prevention Code requires a group H hazardous occupancy operator to provide a Hazardous Materials Management Plan and/or Hazardous Materials Inventory Statement(s), said plans shall be provided by the facility operator on a flash drive that will be stored in an approved plastic bag or similar enclosure within the Knox Box for first responders. The facility operator shall notify the fire code official whenever there is a change or revision to the Hazardous Materials Plan and/or Hazardous Materials Inventory Statement so that current information is available to first responders.

- H. When a commercial occupant re-keys and/or replaces current lock cores or door hardware, it shall be the responsibility of the owner or operator to notify the fire code official and provide an updated key(s) to be placed in the fire department Knox Box on site.
- I. Knox Caps, Plugs, and Padlock Systems:
  - (1) A Knox Cap, Knox Plug, or Knox Padlock provides fire departments in Brunswick County with a means to protect fire sprinkler or fire standpipe systems fire department connections (FDCs) from tampering and malicious damage.
  - (2) A Knox Padlock provides fire departments in Brunswick County with a means to access a locked gate preventing damage associated with cutting padlocks or chains.
  - (3) Knox Caps and Knox Plugs are to be installed by a Brunswick County Code Administration fire code official on new construction and renovated fire sprinkler systems.

### Sec. 3. Fire Hydrants Storz Converter Program

- A. A Storz hydrant converter permanently converts a 4 ½” fire hydrant outlet from NST threads to a Storz connection. Set screws are on the collar of the Storz to ensure its permanent fixture to a fire hydrant. The conversion device reduces the typical connection time for emergency responders versus traditional threaded connections.
- B. A 5” Storz x 4 ½ F NST conversion kit will be required on all new fire hydrants and existing fire hydrants having NST threads within 1,000 feet (via a fire department hose lay method) of new commercial buildings and multi-family buildings occupancies and additions, change of use, or renovations to existing commercial occupancy buildings.

### Sec. 4. Fire Department Connections (FDC) for Fire Sprinkler Systems and Standpipe System Program

- A. Fire Department Connections are used for fire sprinkler systems and fire standpipe systems utilized to connect fire hoses to either maintain pressure where a building is equipped with a fire sprinkler system or to supply water to remote fire standpipe systems utilized by firefighters to connect prepared fire hoses for suppression efforts for fire ground operations.
  - (1) When a Fire Department Connection is required by the North Carolina State Building Code: Fire Prevention Code for a fire sprinkler system or standpipe system, the FDCs shall be of compatible size and type for local responding fire apparatus as indicated by the local fire district Fire Chief to the fire code official with Brunswick County Code Administration.
  - (2) When a Fire Department Connection is required by the North Carolina State Building Code: Fire Prevention Code for a fire sprinkler system or standpipe system, the FDCs shall be located within a maximum of 50’ feet from a fire hydrant.

## Sec. 5. Fireworks, Blasting, and Pyrotechnic Events Program

A. Fireworks classified as 1.3G are explosives classified as display fireworks. These explosives require an active display operator license issued by the Office of the State Fire Marshal (OSFM), North Carolina Department of Insurance (NCDOI), pursuant to NCGS § 14-410.

- (1) An application for an explosives, blasting, or pyrotechnic event shall be submitted to Brunswick County Code Administration a minimum of three (3) weeks prior to the event to allow adequate time to complete a fire plan review and pre-site inspection, to include, but not limited to, the discharge site, spectator viewing, parking, and fallout areas prior to the fire code official issuing or denying a mandatory explosives permit.
- (2) A post-display inspection and accounting for unexploded devices is required by the NCDOI licensed operator and must be witnessed by the fire code official. All mortars shall be painted orange, red, or similar color approved by the fire code official. The intent is to readily identify a “dud” mortar that failed to explode during a display show within the fallout area.
- (3) A pre-display inspection where fireworks are placed on a barge. Once in position, the distance should be verified by a Brunswick County Sheriff’s Office radar device or other approved calibrated measuring device by the fire code official related to the pre-approved fallout zone site plan.

## **Division 7. Fire Prevention Specifications**

In addition to the current edition of the North Carolina State Building Code: Fire Prevention Code as adopted by the North Carolina Building Code Council and as amended, portions of Appendices B, C, and D are adopted as shown herein:

### **Appendix B “Fire Flow Requirements For Buildings”**

#### Section B101.1 General

B101.1 *Scope*. The procedure for determining fire-flow requirements for buildings or portions of buildings hereafter constructed shall be in accordance with this appendix. This appendix does not apply to structures other than buildings.

#### Section B102.1 Definitions

B102.1 *Definitions*. For the purpose of this appendix, certain terms are defined as follows:

**FIRE-FLOW**. The flow rate of a water supply, measured at 20 pounds per square inch (psi) (138 kPa) residual pressure, that is available for firefighting.

**FIRE-FLOW CALCULATION AREA**. The floor area, in square feet (m<sup>2</sup>), used to determine the required fire flow.

#### Section B103 Modifications

B103.1 *Decreases*. The fire chief is authorized to reduce the fire-flow requirements for isolated buildings or a group of buildings in rural areas or small communities where the development of full fire-flow requirements is impractical.

B103.2 *Increases*. The fire chief is authorized to increase the fire-flow requirements where conditions indicate an unusual susceptibility to group fires or conflagrations. An increase shall not be more than twice that required for the building under consideration.

B103.3 *Areas without water supply systems*. For information regarding water supplies for fire-fighting purposes in rural and suburban areas in which adequate and reliable water supply systems do not exist, the fire code official is authorized to utilize NFPA 1142 or the International Wildland-Urban Interface Code.

#### Section B104 Fire-Flow Calculation Area

B104.1 *General*. The fire-flow calculation area shall be the total floor area of all floor levels within the exterior walls, and under the horizontal projections of the roof of a building, except as modified in Section B104.3.

B104.2 *Area separation*. Portions of buildings which are separated by fire walls without openings, constructed in accordance with the International Building Code, are allowed to be considered as separate fire-flow calculation areas.

B104.3 *Type IA and Type IB construction*. The fire-flow calculation area of buildings constructed of Type IA and Type IB construction shall be the area of the three largest successive floors. Exception: Fire-flow calculation area for open parking garages shall be determined by the area of the largest floor.

#### Section B105 Fire-Flow Requirements For Buildings

B105.1 *One- and two-family dwellings*. The minimum fire-flow and flow duration requirements for one- and two-family dwellings having a fire-flow calculation area that does not exceed 3,600 square feet (344.5 m<sup>2</sup>) shall be 1,000 gallons per minute (3785.4 L/min) for 1 hour. Fire-flow and flow duration for dwellings having a fire-flow calculation area in excess of 3,600 square feet (344.5m<sup>2</sup>) shall not be less than that specified in Table B105.1. Exception: A reduction in required fire-flow of 50 percent, as approved, is allowed when the building is equipped with an approved automatic sprinkler system.

B105.2 *Buildings other than one- and two-family dwellings*. The minimum fire-flow and flow duration for buildings other than one- and two-family dwellings shall be as specified in Table B105.1. Exception: A reduction in required fire-flow of up to 75 percent, as approved, is allowed when the building is provided with an approved automatic sprinkler system installed in accordance with Section 903.3.1.1 or 903.3.1.2. The resulting fire-flow shall not be less than 1,500 gallons per minute (5678 L/min) for the prescribed duration as specified in Table B105.1

**A. TABLE B105.1 MINIMUM REQUIRED FIRE-FLOW AND FLOW DURATION FOR BUILDINGS**

FIRE-FLOW CALCULATION AREA (square feet)					FIRE-FLOW (gallons per minute) <sup>b</sup>	FLOW DURATION (hours)
Type IA and IB <sup>a</sup>	Type IIA and IIIA <sup>a</sup>	Type IV and V-A <sup>a</sup>	Type IIB and IIIB <sup>a</sup>	Type V-B <sup>a</sup>		
0-22,700	0-12,700	0-8,200	0-5,900	0-3,600	1,500	2
22,701-30,200	12,701-17,000	8,201-10,900	5,901-7,900	3,601-4,800	1,750	
30,201-38,700	17,001-21,800	10,901-12,900	7,901-9,800	4,801-6,200	2,000	
38,701-48,300	21,801-24,200	12,901-17,400	9,801-12,600	6,201-7,700	2,250	
48,301-59,000	24,201-33,200	17,401-21,300	12,601-15,400	7,701-9,400	2,500	
59,001-70,900	33,201-39,700	21,301-25,500	15,401-18,400	9,401-11,300	2,750	
70,901-83,700	39,701-47,100	25,501-30,100	18,401-21,800	11,301-13,400	3,000	3
83,701-97,700	47,101-54,900	30,101-35,200	21,801-25,900	13,401-15,600	3,250	
97,701-112,700	54,901-63,400	35,201-40,600	25,901-29,300	15,601-18,000	3,500	
112,701-128,700	63,401-72,400	40,601-46,400	29,301-33,500	18,001-20,600	3,750	
128,701-145,900	72,401-82,100	46,401-52,500	33,501-37,900	20,601-23,300	4,000	4
145,901-164,200	82,101-92,400	52,501-59,100	37,901-42,700	23,301-26,300	4,250	
164,201-183,400	92,401-103,100	59,101-66,000	42,701-47,700	26,301-29,300	4,500	
183,401-203,700	103,101-114,600	66,001-73,300	47,701-53,000	29,301-32,600	4,750	
203,701-225,200	114,601-126,700	73,301-81,100	53,001-58,600	32,601-36,000	5,000	
225,201-247,700	126,701-139,400	81,101-89,200	58,601-65,400	36,001-39,600	5,250	
247,701-271,200	139,401-152,600	89,201-97,700	65,401-70,600	39,601-43,400	5,500	
271,201-295,900	152,601-166,500	97,701-106,500	70,601-77,000	43,401-47,400	5,750	
295,901-Greater	166,501-Greater	106,501-115,800	77,001-83,700	47,401-51,500	6,000	
—	—	115,801-125,500	83,701-90,600	51,501-55,700	6,250	
—	—	125,501-135,500	90,601-97,900	55,701-60,200	6,500	
—	—	135,501-145,800	97,901-106,800	60,201-64,800	6,750	
—	—	145,801-156,700	106,801-113,200	64,801-69,600	7,000	
—	—	156,701-167,900	113,201-121,300	69,601-74,600	7,250	
—	—	167,901-179,400	121,301-129,600	74,601-79,800	7,500	
—	—	179,401-191,400	129,601-138,300	79,801-85,100	7,750	
—	—	191,401-Greater	138,301-Greater	85,101-Greater	8,000	

For SI: 1 square foot = 0.0929 m<sup>2</sup>, 1 gallon per minute = 3.785 L/m, 1 pound per square inch = 6.895 kPa.

<sup>a</sup>Types of construction are based on the *International Building Code*.

Measured at 20 psi residual pressure.

<sup>b</sup>Or as approved by the fire code official.

## Appendix C Fire Hydrant Locations and Distribution

### Section C101 General

C101.1 *Scope*. Fire hydrants shall be provided in accordance with this appendix for the protection of buildings, or portions of buildings, hereafter constructed.

### Section C102 Location

C102.1 *Fire hydrant locations*. Fire hydrants shall be provided along required fire apparatus access roads and adjacent public streets.

### Section C103 Number of Fire Hydrants

C103.1 *Fire hydrants available*. The minimum number of fire hydrants available to a building shall not be less than that listed in Table C105.1. The number of fire hydrants available to a complex or subdivision shall not be less than that determined by spacing requirements listed in Table C105.1 when applied to fire apparatus access roads and perimeter public streets from which fire operations could be conducted.

### Section C104 Consideration of Existing Fire Hydrants

C104.1 *Existing fire hydrants*. Existing fire hydrants on public streets are allowed to be considered as available. Existing fire hydrants on adjacent properties shall not be considered available unless fire apparatus access roads extend between properties and easements are established to prevent obstruction of such roads.

### Section C105 Distribution of Fire Hydrants

C105.1 *Hydrant spacing*. The average spacing between fire hydrants shall not exceed that listed in Table C105.1. Exception: The fire chief is authorized to accept a deficiency of up to 10 percent where existing fire hydrants provide all or a portion of the required fire hydrant service. Regardless of the average spacing, fire hydrants shall be located such that all points on streets and access roads adjacent to a building are within the distances listed in Table C105.1. or as approved by the fire code official.

#### A. Table C105.1 Number and Distribution of Fire Hydrants

**TABLE C105.1  
NUMBER AND DISTRIBUTION OF FIRE HYDRANTS**

<b>FIRE-FLOW REQUIREMENT (gpm)</b>	<b>MINIMUM NUMBER OF HYDRANTS</b>	<b>AVERAGE SPACING BETWEEN HYDRANTS<sup>a, b, c</sup> (feet)</b>	<b>MAXIMUM DISTANCE FROM ANY POINT ON STREET OR ROAD FRONTAGE TO A HYDRANT<sup>d</sup></b>
1,750 or less	1	500	250
2,000-2,250	2	450	225
2,500	3	450	225
3,000	3	400	225



3,500-4,000	4	350	210
4,500-5,000	5	300	180
5,500	6	300	180
6,000	6	250	150
6,500-7,000	7	250	150
7,500 or more	8 or more <sup>e</sup>	200	120

For SI: 1 foot = 304.8 mm, 1 gallon per minute = 3.785 L/m.

<sup>a</sup>Reduce by 100 feet for dead-end streets or roads.

<sup>b</sup>Where streets are provided with median dividers which cannot be crossed by fire fighters pulling hose lines, or where arterial streets are provided with four or more traffic lanes and have a traffic count of more than 30,000 vehicles per day, hydrant spacing shall average 500 feet on each side of the street and be arranged on an alternating basis up to a fire-flow requirement of 7,000 gallons per minute and 400 feet for higher fire-flow requirements.

<sup>c</sup>Where new water mains are extended along streets where hydrants are not needed for protection of structures or similar fire problems, fire hydrants shall be provided at spacing not to exceed 1,000 feet to provide for transportation hazards.

<sup>d</sup>Reduce by 50 feet for dead-end streets or roads.

<sup>e</sup>One hydrant for each 1,000 gallons per minute or fraction thereof.

## Appendix D Fire Apparatus Access Roads

### Section D101 General

D101.1 *Scope*. Fire apparatus access roads shall be in accordance with this appendix and all other applicable requirements of the *International Fire Code*.

### Section D102 Required Access

D102.1 *Access and loading*. Facilities, buildings or portions of buildings hereafter constructed shall be accessible to fire department apparatus by way of an approved fire apparatus access road with an asphalt, concrete or other approved driving surface capable of supporting the imposed load of fire apparatus weighing at least 75,000 pounds (34 050 kg).

### Section D103 Minimum Specifications

D103.3 *Turning radius*. The minimum turning radius shall be determined by the fire code official.

D103.4 *Dead ends*. Dead-end fire apparatus access roads in excess of 150 feet (45 720 mm) shall be provided with width and turnaround provisions in accordance with Table D103.4.

**TABLE D103.4 REQUIREMENTS FOR DEAD-END FIRE APPARATUS ACCESS ROADS**

LENGTH (feet)	WIDTH (feet)	TURNAROUNDS REQUIRED
0-150	20	None required
151-500	20	120-foot Hammerhead, 60-foot "Y" or 96-foot-diameter cul-de-sac in accordance with Figure D103.1
501-750	26	120-foot Hammerhead, 60-foot "Y" or 96-foot-diameter cul-de-sac in accordance with Figure D103.1
Over 750		Special approval required

For SI: 1 foot = 304.8 mm.

**FIGURE D103.1  
DEAD-END FIRE APPARATUS ACCESS ROAD  
TURNAROUND**

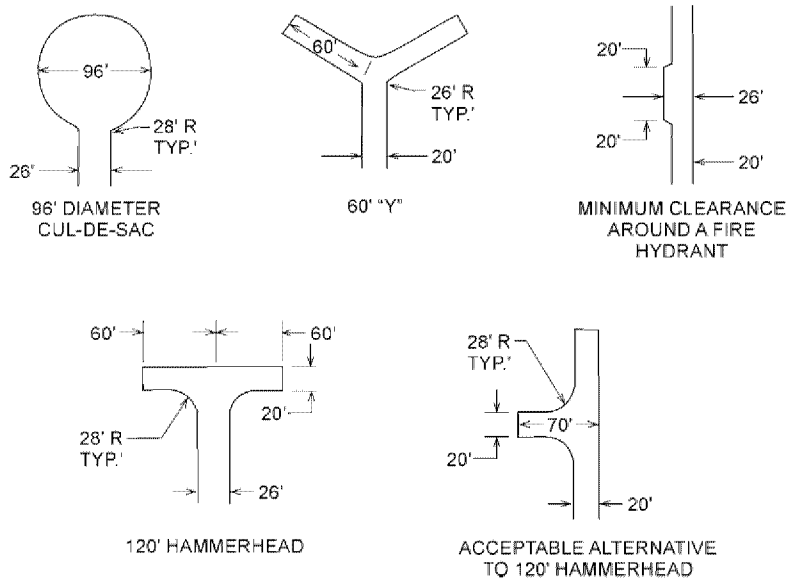

D103.5 *Fire apparatus access road gates.* Gates securing the fire apparatus access roads shall comply with all of the following criteria:

- A. The minimum gate width shall be 20 feet (6096 mm).
- B. Gates shall be of the swinging or sliding type.
- C. Construction of gates shall be of materials that allow manual operation by one person.

- D. Gate components shall be maintained in an operative condition at all times and replaced or repaired when defective.
- E. Electric gates shall be equipped with a means of opening the gate by fire department personnel for emergency access. Emergency opening devices shall be *approved* by the *fire code official*.
- F. Manual opening gates shall not be locked with a padlock or chain and padlock unless they are capable of being opened by means of forcible entry tools or when a key box containing the key(s) to the lock is installed at the gate location.
- G. Locking device specifications shall be submitted for approval by the *fire code official*.
- H. Electric gate operators, where provided, shall be *listed* in accordance with UL 325.
- I. Gates intended for automatic operation shall be designed, constructed and installed to comply with the requirements of ASTM F 2200.

D103.6 *Signs*. Where required by the *fire code official* fire apparatus fire lanes shall be marked with permanent NO PARKING—FIRE LANE marking affixed to the pavement and/or face of curbing shall meet the Brunswick County Fire Lane Marking Specification or as approved by the fire code official.

#### Section D104 Commercial and Industrial Developments

D104.1 Commercial and Multi-Family Structures exceeding 30 feet or three stories in height shall provide at least two means of fire apparatus access.

D104.2 Commercial Structures having a gross enclosed floor area of over 62,000 square feet shall be provided with two separate and approved fire apparatus access roads. However, when equipped throughout with an approved automatic sprinkler system, projects may be allowed to have a gross floor area of up to 124,000 square feet and provide access through one approved access road.

#### Section D105 Fire Department Aerial Apparatus Access Roads

Where fire department aerial apparatus access roads are required in accordance with North Carolina State Building Code: Fire Prevention Code, roads shall meet the Brunswick County aerial apparatus turning radius specification.

D105.1 *Where required*. Commercial and Multi-Family Structures or portions of structures exceeding 30 feet in height above the lowest level of fire department vehicle access shall be provided with approved fire apparatus access roads capable of accommodating fire department aerial apparatus. Overhead utility and power lines shall not be located within the aerial fire apparatus access roadway.

D105.2 *Width*. Fire apparatus access roads shall have a minimum unobstructed width of 26 feet in the immediate vicinity of any building or portion of a commercial or multi-family building more than 30 feet in height.

D105.3 *Proximity to building*. At least one of the required access routes shall be located at least 15 feet, but no more than 30 feet from the structure and shall be parallel to one entire side of the building.

# BRUNSWICK COUNTY FIRE PREVENTION ORDINANCE

## **Divisions**

Division 1. – Administration

Division 2. – Inspections Schedule for Existing Buildings

Division 3. – Permits, Plan Review, and Fees

Division 4. – Civil Penalties

Division 5. – Collection of Fees

Division 6. – Programs

Division 7. – Fire Prevention Specifications

## **Division 1. – Administration**

### Sec. 1. Title

These regulations shall be known and may be cited as the “Fire Prevention Code of Brunswick County” and referenced herein as the “code.”

### Sec. 2. Intent

The intent of this article is to prescribe regulations consistent with nationally-recognized good practices for the safeguarding, to a reasonable degree of life and property, from hazards of fire and explosion arising from the storage, handling, and use of hazardous substances, materials and devices, from conditions hazardous to life and property in the use or occupancy of buildings or premises. Compliance with standards of the American Insurance Association or National Fire Protection Association or other approved nationally-recognized safety standards shall be deemed to be prima facie evidence of compliance with this intent. Nothing in these regulations is intended to limit or prescribe any authority derived from the North Carolina Fire Prevention Code or North Carolina General Statutes.

### Sec. 3. Jurisdiction

This article is effective in unincorporated areas of Brunswick County. It is the responsibility of the Brunswick County Code Administration Department to issue all mandatory fire operational permits, fire construction permits, and, as adopted, optional fire operational permits, conduct all fire inspections for the County, and enforce the provisions of the North Carolina State Building Code: Fire Prevention Code, as adopted by the North Carolina Building Code Council and as amended. The North Carolina State Building Code: Fire Prevention Code is hereby adopted by reference as if fully set forth herein, to the extent such code is applicable for safe and stable design, methods of construction, minimum standards, and use of materials in building or structures hereafter erected, enlarged, altered, repaired, or otherwise constructed or reconstructed.

Amendments to the regulatory codes adopted by reference herein, which are from time to time adopted and published by the North Carolina Building Code Council referred to herein, shall be effective in the County at the time such amendments are filed with the County Chief Building Inspector or his or her designee. An official copy of the North Carolina Fire Prevention Code shall be kept within the Code Administration Department.

#### Sec. 4. Application of Article

- A. The provisions of this article shall apply equally to new and existing conditions, except that existing conditions not in strict compliance with the terms of this article shall be permitted to continue where the exceptions do not constitute a distinct hazard to life or property in the opinion of the Director of Code Administration or his or her acting agent.
- B. Nothing contained in this article shall be construed as applying to the transportation of any article or thing shipped under the jurisdiction of and in compliance with the regulations prescribed by the State Department of Transportation (DOT), nor as applying to the military forces of the United States.
- C. The North Carolina Fire Prevention Code definition of a residential occupancy is a multi-family building. It does not apply to one- and two-family dwellings.
- D. Foster Care Homes shall be operated by the Foster Care Parent in accordance with Chapter 131D of the North Carolina General Statutes and all North Carolina Division of Social Services guidelines and directions.

#### Sec. 5. Appointment and duties of Fire Code Official

- A. *Appointment of Fire Marshal.* The Board of Commissioners shall appoint the Fire Marshal or his or her designee to serve at the pleasure of the Board.
  - (1) Conducting fire prevention inspections of schools as required by Chapter 115C of the North Carolina General Statutes and of day care facilities as authorized by Chapter 110 of the North Carolina General Statutes;
  - (2) Conducting inspections of places of public gathering relative to fire protection and fire prevention;
  - (3) Administering this article.
- B. *Electrical Inspections.* Neither the fire code official nor his or her assistants shall make electrical inspections unless they are qualified to do so under NCGS § 153A-351.

#### Sec. 6. Inspection of buildings and premises

It shall be the duty of a fire code official to inspect, or cause to be inspected, all buildings and premises except the interiors of dwellings, as often as may be necessary, for the purpose of ascertaining and causing to be corrected any conditions liable to cause fire, endanger life from fire, or any violations of the provisions or intent of this article affecting the fire hazard.

## Sec. 7. Orders to eliminate dangerous or hazardous conditions

Whenever the fire code official shall find in any building or upon any premises dangerous or hazardous conditions, he or she shall order the dangerous conditions or materials to be removed or remedied.

If buildings or other premises are owned by one person and occupied by another under lease or otherwise, the orders issued in connection with the enforcing of this article shall apply to the occupants thereof, except where the rules or orders require the making of additions to or changes in the premises themselves, as such would immediately become real estate and be the property of the owner of the premises. In those cases, the rules or orders shall apply to the owner and not the occupant unless it is otherwise agreed between the owner and the occupant.

Dangerous or hazardous conditions include, but are not limited to, the following:

- A. Dangerous or unlawful amounts of combustible, explosive or otherwise hazardous materials;
- B. Hazardous conditions arising from defective or improperly installed equipment for handling or using combustible, explosive or otherwise hazardous materials;
- C. Dangerous accumulations of rubbish, waste paper, boxes, shavings or other highly combustible materials;
- D. Accumulations of dust or waste material in air conditioning or ventilation systems or of grease in kitchen or other exhaust ducts or inadequate clearances to unprotected combustible materials from hoods, grease extractors and ducts; or
- E. Obstructions to or on fire escapes, designated access openings in exterior walls for Fire Department use, stairs, passageways, doors or windows, liable to interfere with the operations of the Fire Department or egress of occupants in case of fire.

## Sec. 8. Service of orders

The service of orders for the correction of violations of this article shall be made upon the owner, occupant or other person responsible for the conditions in any manner allowed by law.

### **Division 2. Inspection Schedule for Existing Buildings**

#### Sec. 1. Fire Inspection and permit fees

Fire inspection and permit fees shall be as set by the Brunswick County Board of Commissioners.

#### Sec. 2. Frequency of Inspection

The minimum frequency of inspections for existing buildings shall be in accordance with the North Carolina State Building Code: Fire Prevention Code, as adopted by the North Carolina Building Code Council and as amended.

### **Division 3. Permits, Plan Review and Fees**

#### Sec. 1. Permits required

*Fire construction permit.* No person shall commence or proceed with the installation, extension, alteration or general repair of any fire protection system without obtaining a permit

from the fire code official. Permits do not apply to one- or two-family dwellings. A construction permit shall be obtained from the Brunswick County Code Administration Department in the following situations or activities:

105.7.1	Automatic fire-extinguishing Systems
105.7.2	Battery Systems (greater than 50 gallons)
105.7.3	Compressed Gases
105.7.4	Cryogenic Fluids
105.7.5	Fire Alarm and Detection Systems and Related equipment
105.7.6	Fire Pumps and Related Equipment
105.7.7	Flammable and Combustible Liquids
105.7.8	Hazardous Materials
105.7.9	Industrial Ovens
105.7.10	LP Gas Installation and modification (Applies only to occupancies covered by the NC Fire Prevention Code)
105.7.11	Private Fire Hydrants
105.7.12	Spraying and Dipping
105.7.13	Standpipe Systems with Sprinkler System
105.7.13	Standpipe Systems without a Sprinkler System
105.7.14	Temporary Membrane structures, tents, and canopies

*Operational Permit.* A mandatory operational permit shall be obtained for all existing and new buildings for the below situations or activities. All operation permit fees are included in the mandatory inspection fees. These permits do not apply to one- or two-family dwellings.

105.6.2	Amusement Buildings
105.6.4	Carnivals and fairs
105.6.6	Combustible dust-producing operations
105.6.9	Covered Malls, Buildings
105.6.13	Exhibits and trade shows
105.6.14	Explosives [Manufacturing, Storage, Handling, & Sale or use of explosives, fireworks, explosive material (60-day permit)]
105.6.16	Flammable and Combustible Liquids: Production, processing, transportation, storage, dispensed, used
105.6.16	Flammable and Combustible Liquids: Tank out of service (More than 90 days)
105.6.16	Flammable and Combustible Liquids: Install, alter, remove, or abandon flammable or combustible liquid tanks
105.6.16	Flammable and Combustible Liquids: Change the contents of a flammable or combustible liquid tank
105.6.16	Manufacture, process, blend, or refine flammable or combustible liquids
105.6.16	To engage in the dispensing of liquids fuels into the fuel tanks of motor vehicles at commercial, industrial, governmental or manufacturing establishments.

105.6.16	To utilize a site for the dispensing of liquid fuels from tank vehicles into the fuel tanks of motor vehicles at commercial, industrial, governmental, or manufacturing establishments
105.6.19	Fumigation and thermal insecticidal fogging
105.6.35	Private fire hydrants (Removal from service, use or operation)
105.6.36	Pyrotechnic special effect's materials
105.6.41	Spraying and dipping
105.6.43	Temporary Membrane structures, tents, and canopies

#### Division 4. Civil Penalties

##### Sec. 1. Civil Penalties

Any person who violates any of the provisions of the North Carolina State Building Code: Fire Prevention Code or the Fire Prevention Code of Brunswick County or who violates or fails to comply with any order made thereunder, or who shall build in violation of any detailed statement of specifications or plans submitted and approved thereunder, or any certificate or permit issued thereunder, shall be subject to penalties as listed in this article.

These penalties shall be recovered by the County in a civil action in the nature of a debt if the offender does not pay the penalties within a period of thirty (30) days after the issuance of the notice of violation. The notice of violation shall be in writing and served as allowed by law. Each day's continuing violation shall be a separate and distinct offense. Any action to recover such penalties may be joined in an action for appropriate equitable remedy, including injunctions and orders of abatement and including an action to recover damages by the County in abating, correcting, limiting, and otherwise dealing with the harmful effects of the offending action.

Fire Code Reference	Violation Description	Penalty Amount
Civil Penalties for non-compliant conditions or activities are as follows:		
105.3.5	Permit not posted or kept on premises	\$50.00
307.2	Unpermitted open burning (Immediate)	\$50.00
308.1.2	Careless use of ignited object (Immediate)	\$50.00
603.7	Use of non-approved heating appliance	\$50.00
703.1	Breach in fire wall/fire stops	\$50.00
703.2	Fire or exit door inoperative	\$100.00
703.2	Fire tower door open (Immediate)	\$100.00
703.2	Opening protectives not maintained per NFPA 80	\$50.00
310.3	"No Smoking" signs not posted where appropriate	\$50.00
310.2	Smoking in prohibited areas (Immediate)	\$100.00
901.4	Sprinkler or fire alarm inoperable	\$100.00
507.5.2	Fire hydrants not complying with code	\$50.00
903.1	Sprinkler system not complying with code	\$50.00
905.1	Standpipe system not complying with code	\$50.00
315.2.1	Sprinkler head(s) blocked/covered (Immediate)	\$50.00
505.1	Street address numbers not posted	\$50.00



505.1	Street address numbers not visible	\$50.00
901	Sprinkler/standpipe needs testing	\$100.00
901	Fire alarm system needs testing	\$100.00
1005.1	Storage in or on fire escape (Immediate)	\$100.00
1005.1	Blocked egress (Immediate)	\$100.00
1005.1	Locked exit doors (Immediate)	\$100.00
1005.1	Overcrowding (Immediate)	\$500.00
1003.6	Fire exit or aisle blocked (Immediate)	\$100.00
315.2.2	Storage in or on fire escape (Immediate)	\$100.00
1003.6	Exit or egress door needs repair	\$50.00
315.2.2	Blocked stairwells or stairways (Immediate)	\$100.00
1006.1	Exit illumination and marking	\$50.00
1011.1	Absence of required exit directional signs	\$50.00
404.2	Approved fire evacuation plan required	\$50.00
405.5	Fire drill performance not acceptable	\$50.00
405.2	No monthly fire drill reported	\$50.00
3405.3	Improper use of flammable liquids (Immediate)	\$100.00
3404.3.5	Flammable liquid not stored according to code	\$50.00
3405.2.5	Improper dispensing of flammable liquid (Immediate)	\$100.00
3404.4.3	Above-ground tanks not diked	\$50.00
2703.2.4	Tank installation not according to code	\$50.00
3404	Tank storage not according to code	\$50.00
1504.1	Spray painting in non-approved area	\$100.00
1504.1.2	Spray booth not complying to code	\$100.00
3003.5.3	Compressed gas cylinders not secured	\$50.00
105.1.2	No hazardous materials permit	\$50.00
2704	Chemical storage is not according to code	\$100.00
1004.3	Maximum occupancy not posted	\$50.00
308.1.4	Use of open flame cooking device	\$50.00
105.1.1	Failure to get tank work permit prior to work	\$200.00
105.2	Failure to obtain permits required by code	\$200.00
906.2	Portable fire extinguisher needing serving, tags, maintenance	\$50.00
904.4	Alternative Automatic Fire-Extinguishing Systems needs testing	\$100.00
112.1	All other violations of the code	\$50.00

*NOTE: The term "Immediate" as it appears above means that the fire code official may issue a citation immediately and the violation must be corrected by the violating party immediately.*

## **Division 5. Collection of Fees**

### **Sec. 1. Collection of fees**

- A. *Plan review fees.* Plan review fees shall be collected by Brunswick County Central Permitting prior to issuance of any building or fire permits.
- B. *Inspection fees (new construction).* In the event additional fees are required to be assessed during a construction project, any and all fees must be paid in full prior to the issuance of the certificate of occupancy. Occupying a building that has not been issued a certificate of occupancy will constitute a civil penalty for each day of the continued offense.
- C. *Inspection fees (existing buildings).* The fee for an inspection of an existing building shall be assessed and an invoice will be supplied to the owner, occupant, or designee. The responsible party will have thirty (30) days to remit payment. After thirty (30) days, the bill will be placed in a past due status and a second invoice will be sent to the responsible party. After a period of sixty (60) days of non-payment, the account will be subject to a ten percent (10%) late fee. The County will pursue legal action after a period of ninety (90) days of non-payment. Debts in excess of \$50.00 dollars that have been delinquent sixty (60) days or more will be recovered through the North Carolina Government Debt Setoff Clearinghouse in accordance with Chapter 105A of the North Carolina General Statutes, known as the "Setoff Debt Collection Act."

## **Division 6. Programs**

### **Sec. 1. Rural Water Supply Sites Program**

- A. When a rural water supply point is used to meet minimum fire flow requirements, the project applicant or agent shall provide the following supporting documentation at the time of application to Brunswick County Code Administration:
  - (1) A completed North Carolina Office of the State Fire Marshal RRS agreement form to grant permission by the property owner to the fire department and mutual aid departments for all emergencies as deemed necessary by the fire chief officer or as approved by the fire code official.
  - (2) A completed North Carolina Office of the State Fire Marshal RSS verification of engineer form completed by a North Carolina licensed engineer or other approved designee by the fire code official.
- B. The water supply site shall have identification signage in accordance with the North Carolina DOT policy for erection of fire department water point location signs.
- C. Any approved water supply points shall have an approved dry hydrant installed in accordance with NFPA 1142 or other approved alternative equipment in place prior to bringing construction materials to the site.

Sec. 2. Knox Box Program

- A. The Knox Box Program provides fire departments within Brunswick County with a quick and easy means to access a secured building or area during an emergency. It also minimizes potential costly repairs caused by forcible entry and allows the building to be re-secured quickly and easily.
- B. The Knox Box program coordinator shall be the Brunswick County Code Administration Director or his or her designee. The Code Administration Director or his or her designee will review and authorize each order.
- C. For all new construction and existing remodel, renovation or upfit projects and/or where the fire hazard increases to a hazardous occupancy type, the requirement for a Knox Box will be determined by the fire code official in accordance with the North Carolina State Building Code: Fire Prevention Code.
- D. Knox Box Series and key sets should be as followed:

<b>Size of Building</b>	<b>Number of Key Sets</b>	<b>Model Knox Box</b>
1-2 Story	1 set of keys	3200 Series*
3-4 Stories	2 sets of keys	3200 Series*
5-8 Stories	3 sets of keys	4400 Series**
9 Stories and above	4 sets of keys	4400 Series**
Shopping Center less than 10 tenant spaces	1 set of keys	3200 Series*
Shopping Center more than 10 tenant spaces	2 sets of keys	4400 Series**

*\*Capacity less than 10 keys total. \*\*Capacity less than 50 keys total.*

- E. A Brunswick County Code Administration fire code official will assist the owner or operator with tagging and labeling individual keys. Keys should include, but are not limited to, a gate, main entrance, grand master, elevator control, mechanical room, fire alarm panel, sprinkler riser room, electrical room, and roof access.
- F. Knox boxes should be installed within ten (10) feet of the main entrance to a building at a height not to exceed five (5) feet above finished grade measured from the top of box. Other locations may be considered by the fire code official on a case-by-case basis.
- G. When the North Carolina State Building Code: Fire Prevention Code requires a group H hazardous occupancy operator to provide a Hazardous Materials Management Plan and/or Hazardous Materials Inventory Statement(s), said plans shall be provided by the facility operator on a flash drive that will be stored in an approved plastic bag or similar enclosure within the Knox Box for first responders. The facility operator shall notify the fire code official whenever there is a change or revision to the Hazardous Materials Plan and/or Hazardous Materials Inventory Statement so that current information is available to first responders.

- H. When a commercial occupant re-keys and/or replaces current lock cores or door hardware, it shall be the responsibility of the owner or operator to notify the fire code official and provide an updated key(s) to be placed in the fire department Knox Box on site.
- I. Knox Caps, Plugs, and Padlock Systems:
  - (1) A Knox Cap, Knox Plug, or Knox Padlock provides fire departments in Brunswick County with a means to protect fire sprinkler or fire standpipe systems fire department connections (FDCs) from tampering and malicious damage.
  - (2) A Knox Padlock provides fire departments in Brunswick County with a means to access a locked gate preventing damage associated with cutting padlocks or chains.
  - (3) Knox Caps and Knox Plugs are to be installed by a Brunswick County Code Administration fire code official on new construction and renovated fire sprinkler systems.

### Sec. 3. Fire Hydrants Storz Converter Program

- A. A Storz hydrant converter permanently converts a 4 ½” fire hydrant outlet from NST threads to a Storz connection. Set screws are on the collar of the Storz to ensure its permanent fixture to a fire hydrant. The conversion device reduces the typical connection time for emergency responders versus traditional threaded connections.
- B. A 5” Storz x 4 ½ F NST conversion kit will be required on all new fire hydrants and existing fire hydrants having NST threads within 1,000 feet (via a fire department hose lay method) of new commercial buildings and multi-family buildings occupancies and additions, change of use, or renovations to existing commercial occupancy buildings.

### Sec. 4. Fire Department Connections (FDC) for Fire Sprinkler Systems and Standpipe System Program

- A. Fire Department Connections are used for fire sprinkler systems and fire standpipe systems utilized to connect fire hoses to either maintain pressure where a building is equipped with a fire sprinkler system or to supply water to remote fire standpipe systems utilized by firefighters to connect prepared fire hoses for suppression efforts for fire ground operations.
  - (1) When a Fire Department Connection is required by the North Carolina State Building Code: Fire Prevention Code for a fire sprinkler system or standpipe system, the FDCs shall be of compatible size and type for local responding fire apparatus as indicated by the local fire district Fire Chief to the fire code official with Brunswick County Code Administration.
  - (2) When a Fire Department Connection is required by the North Carolina State Building Code: Fire Prevention Code for a fire sprinkler system or standpipe system, the FDCs shall be located within a maximum of 50’ feet from a fire hydrant.

## Sec. 5. Fireworks, Blasting, and Pyrotechnic Events Program

- A. Fireworks classified as 1.3G are explosives classified as display fireworks. These explosives require an active display operator license issued by the Office of the State Fire Marshal (OSFM), North Carolina Department of Insurance (NCDOI), pursuant to NCGS § 14-410.
- (1) An application for an explosives, blasting, or pyrotechnic event shall be submitted to Brunswick County Code Administration a minimum of three (3) weeks prior to the event to allow adequate time to complete a fire plan review and pre-site inspection, to include, but not limited to, the discharge site, spectator viewing, parking, and fallout areas prior to the fire code official issuing or denying a mandatory explosives permit.
  - (2) A post-display inspection and accounting for unexploded devices is required by the NCDOI licensed operator and must be witnessed by the fire code official. All mortars shall be painted orange, red, or similar color approved by the fire code official. The intent is to readily identify a “dud” mortar that failed to explode during a display show within the fallout area.
  - (3) A pre-display inspection where fireworks are placed on a barge. Once in position, the distance should be verified by a Brunswick County Sheriff’s Office radar device or other approved calibrated measuring device by the fire code official related to the pre-approved fallout zone site plan.

## Division 7. Fire Prevention Specifications

In addition to the current edition of the North Carolina State Building Code: Fire Prevention Code as adopted by the North Carolina Building Code Council and as amended, portions of Appendices B, C, and D are adopted as shown herein:

### Appendix B “Fire Flow Requirements For Buildings”

#### Section B101.1 General

B101.1 *Scope*. The procedure for determining fire-flow requirements for buildings or portions of buildings hereafter constructed shall be in accordance with this appendix. This appendix does not apply to structures other than buildings.

#### Section B102.1 Definitions

B102.1 *Definitions*. For the purpose of this appendix, certain terms are defined as follows:

**FIRE-FLOW**. The flow rate of a water supply, measured at 20 pounds per square inch (psi) (138 kPa) residual pressure, that is available for firefighting.

**FIRE-FLOW CALCULATION AREA**. The floor area, in square feet (m<sup>2</sup>), used to determine the required fire flow.

#### Section B103 Modifications

B103.1 *Decreases*. The fire chief is authorized to reduce the fire-flow requirements for isolated buildings or a group of buildings in rural areas or small communities where the development of full fire-flow requirements is impractical.

B103.2 *Increases*. The fire chief is authorized to increase the fire-flow requirements where conditions indicate an unusual susceptibility to group fires or conflagrations. An increase shall not be more than twice that required for the building under consideration.

B103.3 *Areas without water supply systems*. For information regarding water supplies for fire-fighting purposes in rural and suburban areas in which adequate and reliable water supply systems do not exist, the fire code official is authorized to utilize NFPA 1142 or the International Wildland-Urban Interface Code.

#### Section B104 Fire-Flow Calculation Area

B104.1 *General*. The fire-flow calculation area shall be the total floor area of all floor levels within the exterior walls, and under the horizontal projections of the roof of a building, except as modified in Section B104.3.

B104.2 *Area separation*. Portions of buildings which are separated by fire walls without openings, constructed in accordance with the International Building Code, are allowed to be considered as separate fire-flow calculation areas.

B104.3 *Type IA and Type IB construction*. The fire-flow calculation area of buildings constructed of Type IA and Type IB construction shall be the area of the three largest successive floors. Exception: Fire-flow calculation area for open parking garages shall be determined by the area of the largest floor.

#### Section B105 Fire-Flow Requirements For Buildings

B105.1 *One- and two-family dwellings*. The minimum fire-flow and flow duration requirements for one- and two-family dwellings having a fire-flow calculation area that does not exceed 3,600 square feet (344.5 m<sup>2</sup>) shall be 1,000 gallons per minute (3785.4 L/min) for 1 hour. Fire-flow and flow duration for dwellings having a fire-flow calculation area in excess of 3,600 square feet (344.5m<sup>2</sup>) shall not be less than that specified in Table B105.1. Exception: A reduction in required fire-flow of 50 percent, as approved, is allowed when the building is equipped with an approved automatic sprinkler system.

B105.2 *Buildings other than one- and two-family dwellings*. The minimum fire-flow and flow duration for buildings other than one- and two-family dwellings shall be as specified in Table B105.1. Exception: A reduction in required fire-flow of up to 75 percent, as approved, is allowed when the building is provided with an approved automatic sprinkler system installed in accordance with Section 903.3.1.1 or 903.3.1.2. The resulting fire-flow shall not be less than 1,500 gallons per minute (5678 L/min) for the prescribed duration as specified in Table B105.1

**A. TABLE B105.1 MINIMUM REQUIRED FIRE-FLOW AND FLOW DURATION FOR BUILDINGS**

FIRE-FLOW CALCULATION AREA (square feet)					FIRE-FLOW (gallons per minute) <sup>b</sup>	FLOW DURATION (hours)
Type IA and IB <sup>a</sup>	Type IIA and IIIA <sup>a</sup>	Type IV and V-A <sup>a</sup>	Type IIB and IIIB <sup>a</sup>	Type V-B <sup>a</sup>		
0-22,700	0-12,700	0-8,200	0-5,900	0-3,600	1,500	2
22,701-30,200	12,701-17,000	8,201-10,900	5,901-7,900	3,601-4,800	1,750	
30,201-38,700	17,001-21,800	10,901-12,900	7,901-9,800	4,801-6,200	2,000	
38,701-48,300	21,801-24,200	12,901-17,400	9,801-12,600	6,201-7,700	2,250	
48,301-59,000	24,201-33,200	17,401-21,300	12,601-15,400	7,701-9,400	2,500	
59,001-70,900	33,201-39,700	21,301-25,500	15,401-18,400	9,401-11,300	2,750	
70,901-83,700	39,701-47,100	25,501-30,100	18,401-21,800	11,301-13,400	3,000	3
83,701-97,700	47,101-54,900	30,101-35,200	21,801-25,900	13,401-15,600	3,250	
97,701-112,700	54,901-63,400	35,201-40,600	25,901-29,300	15,601-18,000	3,500	
112,701-128,700	63,401-72,400	40,601-46,400	29,301-33,500	18,001-20,600	3,750	
128,701-145,900	72,401-82,100	46,401-52,500	33,501-37,900	20,601-23,300	4,000	4
145,901-164,200	82,101-92,400	52,501-59,100	37,901-42,700	23,301-26,300	4,250	
164,201-183,400	92,401-103,100	59,101-66,000	42,701-47,700	26,301-29,300	4,500	
183,401-203,700	103,101-114,600	66,001-73,300	47,701-53,000	29,301-32,600	4,750	
203,701-225,200	114,601-126,700	73,301-81,100	53,001-58,600	32,601-36,000	5,000	
225,201-247,700	126,701-139,400	81,101-89,200	58,601-65,400	36,001-39,600	5,250	
247,701-271,200	139,401-152,600	89,201-97,700	65,401-70,600	39,601-43,400	5,500	
271,201-295,900	152,601-166,500	97,701-106,500	70,601-77,000	43,401-47,400	5,750	
295,901-Greater	166,501-Greater	106,501-115,800	77,001-83,700	47,401-51,500	6,000	
—	—	115,801-125,500	83,701-90,600	51,501-55,700	6,250	
—	—	125,501-135,500	90,601-97,900	55,701-60,200	6,500	
—	—	135,501-145,800	97,901-106,800	60,201-64,800	6,750	
—	—	145,801-156,700	106,801-113,200	64,801-69,600	7,000	
—	—	156,701-167,900	113,201-121,300	69,601-74,600	7,250	
—	—	167,901-179,400	121,301-129,600	74,601-79,800	7,500	
—	—	179,401-191,400	129,601-138,300	79,801-85,100	7,750	
—	—	191,401-Greater	138,301-Greater	85,101-Greater	8,000	

For SI: 1 square foot = 0.0929 m<sup>2</sup>, 1 gallon per minute = 3.785 L/m, 1 pound per square inch = 6.895 kPa.

<sup>a</sup>Types of construction are based on the *International Building Code*.

Measured at 20 psi residual pressure.

<sup>b</sup>Or as approved by the fire code official.

## Appendix C Fire Hydrant Locations and Distribution

### Section C101 General

C101.1 *Scope.* Fire hydrants shall be provided in accordance with this appendix for the protection of buildings, or portions of buildings, hereafter constructed.

### Section C102 Location

C102.1 *Fire hydrant locations.* Fire hydrants shall be provided along required fire apparatus access roads and adjacent public streets.

### Section C103 Number of Fire Hydrants

C103.1 *Fire hydrants available.* The minimum number of fire hydrants available to a building shall not be less than that listed in Table C105.1. The number of fire hydrants available to a complex or subdivision shall not be less than that determined by spacing requirements listed in Table C105.1 when applied to fire apparatus access roads and perimeter public streets from which fire operations could be conducted.

### Section C104 Consideration of Existing Fire Hydrants

C104.1 *Existing fire hydrants.* Existing fire hydrants on public streets are allowed to be considered as available. Existing fire hydrants on adjacent properties shall not be considered available unless fire apparatus access roads extend between properties and easements are established to prevent obstruction of such roads.

### Section C105 Distribution of Fire Hydrants

C105.1 *Hydrant spacing.* The average spacing between fire hydrants shall not exceed that listed in Table C105.1. Exception: The fire chief is authorized to accept a deficiency of up to 10 percent where existing fire hydrants provide all or a portion of the required fire hydrant service. Regardless of the average spacing, fire hydrants shall be located such that all points on streets and access roads adjacent to a building are within the distances listed in Table C105.1. or as approved by the fire code official.

#### A. Table C105.1 Number and Distribution of Fire Hydrants

**TABLE C105.1  
NUMBER AND DISTRIBUTION OF FIRE HYDRANTS**

<b>FIRE-FLOW REQUIREMENT (gpm)</b>	<b>MINIMUM NUMBER OF HYDRANTS</b>	<b>AVERAGE SPACING BETWEEN HYDRANTS<sup>a, b, c</sup> (feet)</b>	<b>MAXIMUM DISTANCE FROM ANY POINT ON STREET OR ROAD FRONTAGE TO A HYDRANT<sup>d</sup></b>
1,750 or less	1	500	250
2,000-2,250	2	450	225
2,500	3	450	225
3,000	3	400	225



3,500-4,000	4	350	210
4,500-5,000	5	300	180
5,500	6	300	180
6,000	6	250	150
6,500-7,000	7	250	150
7,500 or more	8 or more <sup>e</sup>	200	120

For SI: 1 foot = 304.8 mm, 1 gallon per minute = 3.785 L/m.

<sup>a</sup>Reduce by 100 feet for dead-end streets or roads.

<sup>b</sup>Where streets are provided with median dividers which cannot be crossed by fire fighters pulling hose lines, or where arterial streets are provided with four or more traffic lanes and have a traffic count of more than 30,000 vehicles per day, hydrant spacing shall average 500 feet on each side of the street and be arranged on an alternating basis up to a fire-flow requirement of 7,000 gallons per minute and 400 feet for higher fire-flow requirements.

<sup>c</sup>Where new water mains are extended along streets where hydrants are not needed for protection of structures or similar fire problems, fire hydrants shall be provided at spacing not to exceed 1,000 feet to provide for transportation hazards.

<sup>d</sup>Reduce by 50 feet for dead-end streets or roads.

<sup>e</sup>One hydrant for each 1,000 gallons per minute or fraction thereof.

## Appendix D Fire Apparatus Access Roads

### Section D101 General

D101.1 *Scope.* Fire apparatus access roads shall be in accordance with this appendix and all other applicable requirements of the *International Fire Code*.

### Section D102 Required Access

D102.1 *Access and loading.* Facilities, buildings or portions of buildings hereafter constructed shall be accessible to fire department apparatus by way of an approved fire apparatus access road with an asphalt, concrete or other approved driving surface capable of supporting the imposed load of fire apparatus weighing at least 75,000 pounds (34 050 kg).

### Section D103 Minimum Specifications

D103.3 *Turning radius.* The minimum turning radius shall be determined by the fire code official.

D103.4 *Dead ends.* Dead-end fire apparatus access roads in excess of 150 feet (45 720 mm) shall be provided with width and turnaround provisions in accordance with Table D103.4.

**TABLE D103.4 REQUIREMENTS FOR DEAD-END FIRE APPARATUS ACCESS ROADS**

LENGTH (feet)	WIDTH (feet)	TURNAROUNDS REQUIRED
0–150	20	None required
151–500	20	120-foot Hammerhead, 60-foot “Y” or 96-foot-diameter cul-de-sac in accordance with Figure D103.1
501–750	26	120-foot Hammerhead, 60-foot “Y” or 96-foot-diameter cul-de-sac in accordance with Figure D103.1
Over 750		Special approval required

For SI: 1 foot = 304.8 mm.

**FIGURE D103.1  
DEAD-END FIRE APPARATUS ACCESS ROAD  
TURNAROUND**

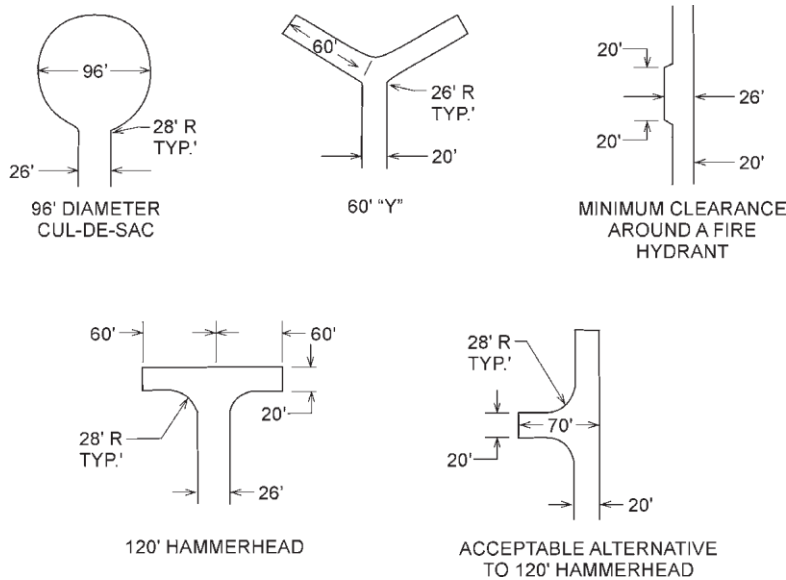

D103.5 *Fire apparatus access road gates.* Gates securing the fire apparatus access roads shall comply with all of the following criteria:

- A. The minimum gate width shall be 20 feet (6096 mm).
- B. Gates shall be of the swinging or sliding type.
- C. Construction of gates shall be of materials that allow manual operation by one person.

- D. Gate components shall be maintained in an operative condition at all times and replaced or repaired when defective.
- E. Electric gates shall be equipped with a means of opening the gate by fire department personnel for emergency access. Emergency opening devices shall be *approved* by the *fire code official*.
- F. Manual opening gates shall not be locked with a padlock or chain and padlock unless they are capable of being opened by means of forcible entry tools or when a key box containing the key(s) to the lock is installed at the gate location.
- G. Locking device specifications shall be submitted for approval by the *fire code official*.
- H. Electric gate operators, where provided, shall be *listed* in accordance with UL 325.
- I. Gates intended for automatic operation shall be designed, constructed and installed to comply with the requirements of ASTM F 2200.

D103.6 *Signs*. Where required by the *fire code official* fire apparatus fire lanes shall be marked with permanent NO PARKING—FIRE LANE marking affixed to the pavement and/or face of curbing shall meet the Brunswick County Fire Lane Marking Specification or as approved by the fire code official.

#### Section D104 Commercial and Industrial Developments

D104.1 Commercial and Multi-Family Structures exceeding 30 feet or three stories in height shall provide at least two means of fire apparatus access.

D104.2 Commercial Structures having a gross enclosed floor area of over 62,000 square feet shall be provided with two separate and approved fire apparatus access roads. However, when equipped throughout with an approved automatic sprinkler system, projects may be allowed to have a gross floor area of up to 124,000 square feet and provide access through one approved access road.

#### Section D105 Fire Department Aerial Apparatus Access Roads

Where fire department aerial apparatus access roads are required in accordance with North Carolina State Building Code: Fire Prevention Code, roads shall meet the Brunswick County aerial apparatus turning radius specification.

D105.1 *Where required*. Commercial and Multi-Family Structures or portions of structures exceeding 30 feet in height above the lowest level of fire department vehicle access shall be provided with approved fire apparatus access roads capable of accommodating fire department aerial apparatus. Overhead utility and power lines shall not be located within the aerial fire apparatus access roadway.

D105.2 *Width*. Fire apparatus access roads shall have a minimum unobstructed width of 26 feet in the immediate vicinity of any building or portion of a commercial or multi-family building more than 30 feet in height.

D105.3 *Proximity to building*. At least one of the required access routes shall be located at least 15 feet, but no more than 30 feet from the structure and shall be parallel to one entire side of the building.

## ARTICLE VII. - FIRE PREVENTION AND PROTECTION<sup>[8]</sup>

Footnotes:

--- (8) ---

**Editor's note**— Printed herein is the Brunswick County Fire Prevention Ordinance, as revised by Ord. of October 21, 2019. Formerly, said article pertained to similar subject matter and derived from Ord. of April 1, 2002; Ord. of October 21, 2002.

### DIVISION 1. - TITLE

Sec. 1-9-286. - Title.

These regulations shall be known and may be cited as the "Fire Prevention Code of Brunswick County" and referenced herein as the "code."

( [Ord. of 10-21-19](#) )

Sec. 1-9-287. - Intent.

The intent of this article is to prescribe regulations consistent with nationally-recognized good practices for the safeguarding, to a reasonable degree of life and property, from hazards of fire and explosion arising from the storage, handling, and use of hazardous substances, materials and devices, from conditions hazardous to life and property in the use or occupancy of buildings or premises. Compliance with standards of the American Insurance Association or National Fire Protection Association or other approved nationally-recognized safety standards shall be deemed to be prima facie evidence of compliance with this intent. Nothing in these regulations is intended to limit or prescribe any authority derived from the North Carolina Fire Prevention Code or North Carolina General Statutes.

( [Ord. of 10-21-19](#) )

Sec. 1-9-288. - Jurisdiction.

This article is effective in unincorporated areas of Brunswick County. It is the responsibility of the Brunswick County Code Administration Department to issue all mandatory fire operational permits, fire construction permits, and, as adopted, optional fire operational permits, conduct all fire inspections for the county, and enforce the provisions of the North Carolina State Building Code: Fire Prevention Code, as adopted by the North Carolina Building Code Council and as amended. The North Carolina State Building Code: Fire Prevention Code is hereby adopted by reference as if fully set forth herein, to the extent such code is applicable for safe and stable design, methods of construction, minimum standards, and use of materials in building or structures hereafter erected, enlarged, altered, repaired, or otherwise constructed or reconstructed.

Amendments to the regulatory codes adopted by reference herein, which are from time to time adopted and published by the North Carolina Building Code Council referred to herein, shall be effective in the county at the time such amendments are filed with the county chief building inspector or his or her designee. An official copy of the North Carolina Fire Prevention Code shall be kept within the code administration department.

( [Ord. of 10-21-19](#) )

Sec. 1-9-289. - Application of article.

- (a) The provisions of this article shall apply equally to new and existing conditions, except that existing conditions not in strict compliance with the terms of this article shall be permitted to continue where the exceptions do not constitute a distinct hazard to life or property in the opinion of the director of code administration or his or her acting agent.
- (b) Nothing contained in this article shall be construed as applying to the transportation of any article or thing shipped under the jurisdiction of and in compliance with the regulations prescribed by the State Department of Transportation (DOT), nor as applying to the military forces of the United States.
- (c) The North Carolina Fire Prevention Code definition of a residential occupancy is a multi-family building. It does not apply to one- and two-family dwellings.
- (d) Foster care homes shall be operated by the foster care parent in accordance with chapter 131D of the North Carolina General Statutes and all North Carolina Division of Social Services guidelines and directions.

( [Ord. of 10-21-19](#) )

Sec. 1-9-290. - Appointment and duties of fire code official.

- (a) *Appointment of fire marshal.* The board of commissioners shall appoint the fire marshal or his or her designee to serve at the pleasure of the board.
  - (1) Conducting fire prevention inspections of schools as required by G.S. Ch.115C and of day care facilities as authorized by G.S. Ch. 110;
  - (2) Conducting inspections of places of public gathering relative to fire protection and fire prevention;
  - (3) Administering this article.
- (b) *Electrical inspections.* Neither the fire code official nor his or her assistants shall make electrical inspections unless they are qualified to do so under G.S. § 153A-351.

( [Ord. of 10-21-19](#) )

Sec. 1-9-291. - Inspection of buildings and premises.

It shall be the duty of a fire code official to inspect, or cause to be inspected, all buildings and premises except the interiors of dwellings, as often as may be necessary, for the purpose of ascertaining and causing to be corrected any conditions liable to cause fire, endanger life from fire, or any violations of the provisions or intent of this article affecting the fire hazard.

( [Ord. of 10-21-19](#) )

Sec. 1-9-292. - Orders to eliminate dangerous or hazardous conditions.

Whenever the fire code official shall find in any building or upon any premises dangerous or hazardous conditions, he or she shall order the dangerous conditions or materials to be removed or remedied.

If buildings or other premises are owned by one (1) person and occupied by another under lease or otherwise, the orders issued in connection with the enforcing of this article shall apply to the occupants thereof, except where the rules or orders require the making of additions to or changes in the premises themselves, as such would immediately become real estate and be the property of the owner of the premises. In those cases, the rules or orders shall apply to the owner and not the occupant unless it is otherwise agreed between the owner and the occupant.

Dangerous or hazardous conditions include, but are not limited to, the following:

- (1) Dangerous or unlawful amounts of combustible, explosive or otherwise hazardous materials;
- (2) Hazardous conditions arising from defective or improperly installed equipment for handling or using combustible, explosive or otherwise hazardous materials;
- (3) Dangerous accumulations of rubbish, waste paper, boxes, shavings or other highly combustible materials;
- (4) Accumulations of dust or waste material in air conditioning or ventilation systems or of grease in kitchen or other exhaust ducts or inadequate clearances to unprotected combustible materials from hoods, grease extractors and ducts; or
- (5) Obstructions to or on fire escapes, designated access openings in exterior walls for fire department use, stairs, passageways, doors or windows, liable to interfere with the operations of the fire department or egress of occupants in case of fire.

( [Ord. of 10-21-19](#) )

Sec. 1-9-293. - Service of orders.

The service of orders for the correction of violations of this article shall be made upon the owner, occupant or other person responsible for the conditions in any manner allowed by law.

( [Ord. of 10-21-19](#) )

Secs. 1-9-294—1-9-330. - Reserved.

## DIVISION 2. - INSPECTION SCHEDULE FOR EXISTING BUILDINGS

Sec. 1-9-331. - Fire inspection and permit fees.

Fire inspection and permit fees shall be as set by the Brunswick County Board of Commissioners.

( [Ord. of 10-21-19](#) )

Sec. 1-9-332. - Frequency of inspection.

The minimum frequency of inspections for existing buildings shall be in accordance with the North Carolina State Building Code: Fire Prevention Code, as adopted by the North Carolina Building Code Council and as amended.

( [Ord. of 10-21-19](#) )

Secs. 1-9-333—1-9-375. - Reserved.

## DIVISION 3. - PERMITS, PLAN REVIEW AND FEES

Sec. 1-9-376. - Permits required.

*Fire construction permit.* No person shall commence or proceed with the installation, extension, alteration or general repair of any fire protection system without obtaining a permit from the fire code official. Permits do not apply to one- or two-family dwellings. A construction permit shall be obtained from the Brunswick County Code Administration Department in the following situations or activities:

105.7.1	Automatic fire-extinguishing systems
105.7.2	Battery systems (greater than 50 gallons)
105.7.3	Compressed gases
105.7.4	Cryogenic fluids
105.7.5	Fire alarm and detection systems and related equipment
105.7.6	Fire pumps and related equipment
105.7.7	Flammable and combustible liquids
105.7.8	Hazardous materials
105.7.9	Industrial ovens
105.7.10	LP gas installation and modification (applies only to occupancies covered by the NC Fire Prevention Code)
105.7.11	Private fire hydrants
105.7.12	Spraying and dipping
105.7.13	Standpipe systems with sprinkler system
105.7.13	Standpipe systems without a sprinkler system
105.7.14	Temporary membrane structures, tents, and canopies

*Operational permit.* A mandatory operational permit shall be obtained for all existing and new buildings for the below situations or activities. All operation permit fees are included in the mandatory inspection fees. These permits do not apply to one- or two-family dwellings.

105.6.2	Amusement buildings
105.6.4	Carnivals and fairs

105.6.6	Combustible dust-producing operations
105.6.9	Covered malls, buildings
105.6.13	Exhibits and trade shows
105.6.14	Explosives [Manufacturing, storage, Handling, and sale or use of explosives, fireworks, explosive material (60-day permit)]
105.6.16	Flammable and combustible liquids: Production, processing, transportation, storage, dispended, used
105.6.16	Flammable and combustible liquids: Tank out of service (More than 90 days)
105.6.16	Flammable and combustible liquids: Install, alter, remove, or abandon flammable or combustible liquid tanks
105.6.16	Flammable and combustible liquids: Change the contents of a flammable or combustible liquid tank
105.6.16	Manufacture, process, blend, or refine flammable or combustible liquids
105.6.16	To engage in the dispensing of liquids fuels into the fuel tanks of motor vehicles at commercial, industrial, governmental or manufacturing establishments.
105.6.16	To utilize a site for the dispensing of liquid fuels from tank vehicles into the fuel tanks of motor vehicles at commercial, industrial, governmental, or manufacturing establishments
105.6.19	Fumigation and thermal insecticidal fogging
105.6.35	Private fire hydrants (Removal from service, use or operation)
105.6.36	Pyrotechnic special effect's materials
105.6.41	Spraying and dipping
105.6.43	Temporary membrane structures, tents, and canopies



( [Ord. of 10-21-19](#) )

Secs. 1-9-377—1-9-420. - Reserved.

DIVISION 4. - CIVIL PENALTIES

Sec. 1-9-421. - Civil penalties.

Any person who violates any of the provisions of the North Carolina State Building Code: Fire Prevention Code or the Fire Prevention Code of Brunswick County or who violates or fails to comply with any order made thereunder, or who shall build in violation of any detailed statement of specifications or plans submitted and approved thereunder, or any certificate or permit issued thereunder, shall be subject to penalties as listed in this article.

These penalties shall be recovered by the county in a civil action in the nature of a debt if the offender does not pay the penalties within a period of thirty (30) days after the issuance of the notice of violation. The notice of violation shall be in writing and served as allowed by law. Each day's continuing violation shall be a separate and distinct offense. Any action to recover such penalties may be joined in an action for appropriate equitable remedy, including injunctions and orders of abatement and including an action to recover damages by the county in abating, correcting, limiting, and otherwise dealing with the harmful effects of the offending action.

Fire Code Reference	Violation Description	Penalty Amount
Civil Penalties for non-compliant conditions or activities are as follows:		
105.3.5	Permit not posted or kept on premises	\$50.00
307.2	Unpermitted open burning (Immediate)	\$50.00
308.1.2	Careless use of ignited object (Immediate)	\$50.00
603.7	Use of non-approved heating appliance	\$50.00
703.1	Breach in fire wall/fire stops	\$50.00
703.2	Fire or exit door inoperative	\$100.00
703.2	Fire tower door open (Immediate)	\$100.00
703.2	Opening protectives not maintained per NFPA 80	\$50.00
310.3	"No Smoking" signs not posted where appropriate	\$50.00

310.2	Smoking in prohibited areas (Immediate)	\$100.00
901.4	Sprinkler or fire alarm inoperable	\$100.00
507.5.2	Fire hydrants not complying with code	\$50.00
903.1	Sprinkler system not complying with code	\$50.00
905.1	Standpipe system not complying with code	\$50.00
315.2.1	Sprinkler head(s) blocked/covered (Immediate)	\$50.00
505.1	Street address numbers not posted	\$50.00
505.1	Street address numbers not visible	\$50.00
901	Sprinkler/standpipe needs testing	\$100.00
901	Fire alarm system needs testing	\$100.00
1005.1	Storage in or on fire escape (Immediate)	\$100.00
1005.1	Blocked egress (Immediate)	\$100.00
1005.1	Locked exit doors (Immediate)	\$100.00
1005.1	Overcrowding (Immediate)	\$500.00
1003.6	Fire exit or aisle blocked (Immediate)	\$100.00
315.2.2	Storage in or on fire escape (Immediate)	\$100.00
1003.6	Exit or egress door needs repair	\$50.00
315.2.2	Blocked stairwells or stairways (Immediate)	\$100.00
1006.1	Exit illumination and marking	\$50.00

1011.1	Absence of required exit directional signs	\$50.00
404.2	Approved fire evacuation plan required	\$50.00
405.5	Fire drill performance not acceptable	\$50.00
405.2	No monthly fire drill reported	\$50.00
3405.3	Improper use of flammable liquids (Immediate)	\$100.00
3404.3.5	Flammable liquid not stored according to code	\$50.00
3405.2.5	Improper dispensing of flammable liquid (Immediate)	\$100.00
3404.4.3	Above-ground tanks not diked	\$50.00
2703.2.4	Tank installation not according to code	\$50.00
3404	Tank storage not according to code	\$50.00
1504.1	Spray painting in non-approved area	\$100.00
1504.1.2	Spray booth not complying to code	\$100.00
3003.5.3	Compressed gas cylinders not secured	\$50.00
105.1.2	No hazardous materials permit	\$50.00
2704	Chemical storage is not according to code	\$100.00
1004.3	Maximum occupancy not posted	\$50.00
308.1.4	Use of open flame cooking device	\$50.00
105.1.1	Failure to get tank work permit prior to work	\$200.00
105.2	Failure to obtain permits required by code	\$200.00

906.2	Portable fire extinguisher needing serving, tags, maintenance	\$50.00
904.4	Alternative automatic fire-extinguishing systems needs testing	\$100.00
112.1	All other violations of the code	\$50.00
<p><i>NOTE: The term "Immediate" as it appears above means that the fire code official may issue a citation immediately and the violation must be corrected by the violating party immediately.</i></p>		

( [Ord. of 10-21-19](#) )

Secs. 1-9-422—1-9-465. - Reserved.

#### DIVISION 5. - COLLECTION OF FEES

Sec. 1-9-466. - Collection of fees.

- (a) *Plan review fees.* Plan review fees shall be collected by Brunswick County Central Permitting prior to issuance of any building or fire permits.
- (b) *Inspection fees (new construction).* In the event additional fees are required to be assessed during a construction project, any and all fees must be paid in full prior to the issuance of the certificate of occupancy. Occupying a building that has not been issued a certificate of occupancy will constitute a civil penalty for each day of the continued offense.
- (c) *Inspection fees (existing buildings).* The fee for an inspection of an existing building shall be assessed and an invoice will be supplied to the owner, occupant, or designee. The responsible party will have thirty (30) days to remit payment. After thirty (30) days, the bill will be placed in a past due status and a second invoice will be sent to the responsible party. After a period of sixty (60) days of non-payment, the account will be subject to a ten (10) percent late fee. The county will pursue legal action after a period of ninety (90) days of non-payment. Debts in excess of fifty dollars (\$50.00) that have been delinquent sixty (60) days or more will be recovered through the North Carolina Government Debt Setoff Clearinghouse in accordance with G.S. Ch.105A, known as the "Setoff Debt Collection Act."

( [Ord. of 10-21-19](#) )

Secs. 1-9-467—1-9-510. - Reserved.

#### DIVISION 6. - PROGRAMS

Sec. 1-9-511. - Rural water supply sites program.

- (a) When a rural water supply point is used to meet minimum fire flow requirements, the project applicant or agent shall provide the following supporting documentation at the time of application to Brunswick County Code Administration:

- (1) A completed North Carolina Office of the State Fire Marshal RRS agreement form to grant permission by the property owner to the fire department and mutual aid departments for all emergencies as deemed necessary by the fire chief officer or as approved by the fire code official.
- (2) A completed North Carolina Office of the State Fire Marshal RRS verification of engineer form completed by a North Carolina licensed engineer or other approved designee by the fire code official.
- (b) The water supply site shall have identification signage in accordance with the North Carolina DOT policy for erection of fire department water point location signs.
- (c) Any approved water supply points shall have an approved dry hydrant installed in accordance with NFPA 1142 or other approved alternative equipment in place prior to bringing construction materials to the site.

( [Ord. of 10-21-19](#) )

Sec. 1-9-512. - Knox Box Program.

- (a) The Knox Box Program provides fire departments within Brunswick County with a quick and easy means to access a secured building or area during an emergency. It also minimizes potential costly repairs caused by forcible entry and allows the building to be re-secured quickly and easily.
- (b) The Knox Box program coordinator shall be the Brunswick County Code Administration Director or his or her designee. The code administration director or his or her designee will review and authorize each order.
- (c) For all new construction and existing remodel, renovation or upfit projects and/or where the fire hazard increases to a hazardous occupancy type, the requirement for a Knox Box will be determined by the fire code official in accordance with the North Carolina State Building Code: Fire Prevention Code.
- (d) Knox Box Series and key sets should be as followed:

Size of Building	Number of Key Sets	Model Knox Box
1-2 Story	1 set of keys	3200 Series*
3-4 Stories	2 sets of keys	3200 Series*
5-8 Stories	3 sets of keys	4400 Series**
9 Stories and above	4 sets of keys	4400 Series**
Shopping Center less than 10 tenant spaces	1 set of keys	3200 Series*
Shopping Center more than 10 tenant spaces	2 sets of keys	4400 Series**

\*Capacity less than 10 keys total. \*\*Capacity less than 50 keys total.

- (e) A Brunswick County Code Administration fire code official will assist the owner or operator with tagging and labeling individual keys. Keys should include, but are not limited to, a gate, main entrance, grand master, elevator control, mechanical room, fire alarm panel, sprinkler riser room, electrical room, and roof access.
- (f) Knox boxes should be installed within ten (10) feet of the main entrance to a building at a height not to exceed five (5) feet above finished grade measured from the top of box. Other locations may be considered by the fire code official on a case-by-case basis.
- (g) When the North Carolina State Building Code: Fire Prevention Code requires a group H hazardous occupancy operator to provide a Hazardous Materials Management Plan and/or Hazardous Materials Inventory Statement(s), said plans shall be provided by the facility operator on a flash drive that will be stored in an approved plastic bag or similar enclosure within the Knox Box for first responders. The facility operator shall notify the fire code official whenever there is a change or revision to the Hazardous Materials Plan and/or Hazardous Materials Inventory Statement so that current information is available to first responders.
- (h) When a commercial occupant re-keys and/or replaces current lock cores or door hardware, it shall be the responsibility of the owner or operator to notify the fire code official and provide an updated key(s) to be placed in the fire department Knox Box on site.
- (i) Knox caps, plugs, and padlock systems:
  - (1) A Knox Cap, Knox Plug, or Knox Padlock provides fire departments in Brunswick County with a means to protect fire sprinkler or fire standpipe systems fire department connections (FDCs) from tampering and malicious damage.
  - (2) A Knox Padlock provides fire departments in Brunswick County with a means to access a locked gate preventing damage associated with cutting padlocks or chains.
  - (3) Knox Caps and Knox Plugs are to be installed by a Brunswick County Code Administration fire code official on new construction and renovated fire sprinkler systems.

( [Ord. of 10-21-19](#) )

Sec. 1-9-513. - Fire hydrants Storz Converter Program.

- (a) A Storz hydrant converter permanently converts a four and one-half (4 ½") fire hydrant outlet from NST threads to a Storz connection. Set screws are on the collar of the Storz to ensure its permanent fixture to a fire hydrant. The conversion device reduces the typical connection time for emergency responders versus traditional threaded connections.
- (b) A five (5) inch Storz by four and one-half (4 ½) F NST conversion kit will be required on all new fire hydrants and existing fire hydrants having NST threads within one thousand (1,000) feet (via a fire department hose lay method) of new commercial buildings and multi-family buildings occupancies and additions, change of use, or renovations to existing commercial occupancy buildings.

( [Ord. of 10-21-19](#) )

Sec. 1-9-514. - Fire Department Connections (FDC) for fire sprinkler systems and Standpipe System Program.

- (a) Fire Department Connections are used for fire sprinkler systems and fire standpipe systems utilized to connect fire hoses to either maintain pressure where a building is equipped with a fire sprinkler system or to supply water to remote fire standpipe systems utilized by firefighters to connect prepared fire hoses for suppression efforts for fire ground operations.

- (1) When a Fire Department Connection is required by the North Carolina State Building Code: Fire Prevention Code for a fire sprinkler system or standpipe system, the FDCs shall be of compatible size and type for local responding fire apparatus as indicated by the local fire district Fire Chief to the fire code official with Brunswick County Code Administration.
- (2) When a Fire Department Connection is required by the North Carolina State Building Code: Fire Prevention Code for a fire sprinkler system or standpipe system, the FDCs shall be located within a maximum of fifty (50) feet from a fire hydrant.

( [Ord. of 10-21-19](#) )

Sec. 1-9-515. - Fireworks, Blasting, and Pyrotechnic Events Program.

- (a) Fireworks classified as 1.3G are explosives classified as display fireworks. These explosives require an active display operator license issued by the Office of the State Fire Marshal (OSFM), North Carolina Department of Insurance (NCDI), pursuant to G.S. § 14-410.
  - (1) An application for an explosives, blasting, or pyrotechnic event shall be submitted to Brunswick County Code Administration a minimum of three (3) weeks prior to the event to allow adequate time to complete a fire plan review and pre-site inspection, to include, but not limited to, the discharge site, spectator viewing, parking, and fallout areas prior to the fire code official issuing or denying a mandatory explosives permit.
  - (2) A post-display inspection and accounting for unexploded devices is required by the NCDI licensed operator and must be witnessed by the fire code official. All mortars shall be painted orange, red, or similar color approved by the fire code official. The intent is to readily identify a "dud" mortar that failed to explode during a display show within the fallout area.
  - (3) A pre-display inspection where fireworks are placed on a barge. Once in position, the distance should be verified by a Brunswick County Sheriff's Office radar device or other approved calibrated measuring device by the fire code official related to the pre-approved fallout zone site plan.

( [Ord. of 10-21-19](#) )

Secs. 1-9-516—1-9-555. - Reserved.

#### DIVISION 7. - FIRE PREVENTION SPECIFICATIONS

Sec. 1-9-556. - Fire prevention specifications.

In addition to the current edition of the North Carolina State Building Code: Fire Prevention Code as adopted by the North Carolina Building Code Council and as amended, portions of Appendices B, C, and D are adopted as shown herein:

( [Ord. of 10-21-19](#) )

Secs. 1-9-557—1-9-560. - Reserved.

#### Appendix B. - Fire Flow Requirements for Buildings

Sec. B101. - General.

B101.1 *Scope.* The procedure for determining fire-flow requirements for buildings or portions of buildings hereafter constructed shall be in accordance with this appendix. This appendix does not apply to structures other than buildings.

( [Ord. of 10-21-19](#) )

Sec. B102.1. - Definitions.

B102.1 *Definitions.* For the purpose of this appendix, certain terms are defined as follows:

*Fire-flow.* The flow rate of a water supply, measured at twenty (20) pounds per square inch (psi) (138 kPa) residual pressure, that is available for firefighting.

*Fire-flow calculation area.* The floor area, in square feet (m<sup>2</sup>), used to determine the required fire flow.

( [Ord. of 10-21-19](#) )

Sec. B103. - Modifications.

B103.1 *Decreases.* The fire chief is authorized to reduce the fire-flow requirements for isolated buildings or a group of buildings in rural areas or small communities where the development of full fire-flow requirements is impractical.

B103.2 *Increases.* The fire chief is authorized to increase the fire-flow requirements where conditions indicate an unusual susceptibility to group fires or conflagrations. An increase shall not be more than twice that required for the building under consideration.

B103.3. *Areas without water supply systems.* For information regarding water supplies for fire-fighting purposes in rural and suburban areas in which adequate and reliable water supply systems do not exist, the fire code official is authorized to utilize NFPA 1142 or the International Wildland-Urban Interface Code.

( [Ord. of 10-21-19](#) )

Sec. B104. - Fire-flow calculation area.

B104.1. *General.* The fire-flow calculation area shall be the total floor area of all floor levels within the exterior walls, and under the horizontal projections of the roof of a building, except as modified in section B104.3.

B104.2. *Area separation.* Portions of buildings which are separated by fire walls without openings, constructed in accordance with the International Building Code, are allowed to be considered as separate fire-flow calculation areas.

B104.3. *Type IA and Type IB construction.* The fire-flow calculation area of buildings constructed of Type IA and Type IB construction shall be the area of the three (3) largest successive floors. Exception: Fire-flow calculation area for open parking garages shall be determined by the area of the largest floor.

( [Ord. of 10-21-19](#) )

Sec. B105. - Fire-flow requirements for buildings.

B105.1. *One- and two-family dwellings.* The minimum fire-flow and flow duration requirements for one- and two-family dwellings having a fire-flow calculation area that does not exceed three thousand six



hundred (3,600) square feet (344.5 m<sup>2</sup>) shall be one thousand (1,000) gallons per minute (3785.4 L/min) for one (1) hour. Fire-flow and flow duration for dwellings having a fire-flow calculation area in excess of three thousand six hundred (3,600) square feet (344.5m<sup>2</sup>) shall not be less than that specified in table B105.1. Exception: A reduction in required fire-flow of fifty (50) percent, as approved, is allowed when the building is equipped with an approved automatic sprinkler system.

B105.2. *Buildings other than one- and two-family dwellings.* The minimum fire-flow and flow duration for buildings other than one- and two-family dwellings shall be as specified in table B105.1. Exception: A reduction in required fire-flow of up to seventy-five (75) percent, as approved, is allowed when the building is provided with an approved automatic sprinkler system installed in accordance with section 903.3.1.1 or 903.3.1.2. The resulting fire-flow shall not be less than one thousand five hundred (1,500) gallons per minute (5678 L/min) for the prescribed duration as specified in table B105.1.

TABLE B105.1 MINIMUM REQUIRED FIRE-FLOW AND FLOW DURATION FOR BUILDINGS

FIRE-FLOW CALCULATION AREA (square feet)					FIRE-FLOW (gallons per minute) <sup>b</sup>	FLOW DURATION (hours)
Type IA and IB <sup>a</sup>	Type IIA and IIIA <sup>a</sup>	Type IV and V-A <sup>a</sup>	Type IIB and IIIB <sup>a</sup>	Type V-B <sup>a</sup>		
0-22,700	0-12,700	0-8,200	0-5,900	0-3,600	1,500	2
22,701-30,200	12,701-17,000	8,201-10,900	5,901-7,900	3,601-4,800	1,750	
30,201-38,700	17,001-21,800	10,901-12,900	7,901-9,800	4,801-6,200	2,000	
38,701-48,300	21,801-24,200	12,901-17,400	9,801-12,600	6,201-7,700	2,250	
48,301-59,000	24,201-33,200	17,401-21,300	12,601-15,400	7,701-9,400	2,500	
59,001-70,900	33,201-39,700	21,301-25,500	15,401-18,400	9,401-11,300	2,750	
70,901-83,700	39,701-47,100	25,501-30,100	18,401-21,800	11,301-13,400	3,000	3
83,701-97,700	47,101-54,900	30,101-35,200	21,801-25,900	13,401-15,600	3,250	
97,701-112,700	54,901-63,400	35,201-40,600	25,901-29,300	15,601-18,000	3,500	
112,701-128,700	63,401-72,400	40,601-46,400	29,301-33,500	18,001-20,600	3,750	
128,701-145,900	72,401-82,100	46,401-52,500	33,501-37,900	20,601-23,300	4,000	4
145,901-164,200	82,101-92,400	52,501-59,100	37,901-42,700	23,301-26,300	4,250	

164,201-183,400	92,401-103,100	59,101-66,000	42,701-47,700	26,301-29,300	4,500
183,401-203,700	103,101-114,600	66,001-73,300	47,701-53,000	29,301-32,600	4,750
203,701-225,200	114,601-126,700	73,301-81,100	53,001-58,600	32,601-36,000	5,000
225,201-247,700	126,701-139,400	81,101-89,200	58,601-65,400	36,001-39,600	5,250
247,701-271,200	139,401-152,600	89,201-97,700	65,401-70,600	39,601-43,400	5,500
271,201-295,900	152,601-166,500	97,701-106,500	70,601-77,000	43,401-47,400	5,750
295,901- Greater	166,501- Greater	106,501-115,800	77,001-83,700	47,401-51,500	6,000
—	—	115,801-125,500	83,701-90,600	51,501-55,700	6,250
—	—	125,501-135,500	90,601-97,900	55,701-60,200	6,500
—	—	135,501-145,800	97,901-106,800	60,201-64,800	6,750
—	—	145,801-156,700	106,801-113,200	64,801-69,600	7,000
—	—	156,701-167,900	113,201-121,300	69,601-74,600	7,250
—	—	167,901-179,400	121,301-129,600	74,601-79,800	7,500
—	—	179,401-191,400	129,601-138,300	79,801-85,100	7,750
—	—	191,401- Greater	138,301- Greater	85,101- Greater	8,000

For SI: 1 square foot = 0.0929 m, 1 gallon per minute = 3.785 L/m, 1 pound per square inch = 6.895 kPa.

<sup>a</sup> Types of construction are based on the *International Building Code*.

Measured at 20 psi residual pressure.

<sup>b</sup> Or as approved by the fire code official.

( [Ord. of 10-21-19](#) )

## Appendix C. - Fire Hydrant Locations and Distribution

### Sec. C101. - General.

C101.1. *Scope.* Fire hydrants shall be provided in accordance with this appendix for the protection of buildings, or portions of buildings, hereafter constructed.

( [Ord. of 10-21-19](#) )

### Sec. C102. - Location.

C102.1. *Fire hydrant locations.* Fire hydrants shall be provided along required fire apparatus access roads and adjacent public streets.

( [Ord. of 10-21-19](#) )

### Sec. C103. - Number of fire hydrants.

C103.1. *Fire hydrants available.* The minimum number of fire hydrants available to a building shall not be less than that listed in table C105.1. The number of fire hydrants available to a complex or subdivision shall not be less than that determined by spacing requirements listed in table C105.1 when applied to fire apparatus access roads and perimeter public streets from which fire operations could be conducted.

( [Ord. of 10-21-19](#) )

### Sec. C104. - Consideration of existing fire hydrants.

C104.1. *Existing fire hydrants.* Existing fire hydrants on public streets are allowed to be considered as available. Existing fire hydrants on adjacent properties shall not be considered available unless fire apparatus access roads extend between properties and easements are established to prevent obstruction of such roads.

( [Ord. of 10-21-19](#) )

### Sec. C105. - Distribution of fire hydrants.

C105.1. *Hydrant spacing.* The average spacing between fire hydrants shall not exceed that listed in table C105.1. Exception: The fire chief is authorized to accept a deficiency of up to ten (10) percent where existing fire hydrants provide all or a portion of the required fire hydrant service. Regardless of the average spacing, fire hydrants shall be located such that all points on streets and access roads

adjacent to a building are within the distances listed in table C105.1. or as approved by the fire code official.

TABLE C105.1 NUMBER AND DISTRIBUTION OF FIRE HYDRANTS

FIRE-FLOW REQUIREMENT (gpm)	MINIMUM NUMBER OF HYDRANTS	AVERAGE SPACING BETWEEN HYDRANTS <sup>a, b, c</sup> (feet)	MAXIMUM DISTANCE FROM ANY POINT ON STREET OR ROAD FRONTAGE TO A HYDRANT <sup>d</sup>
1,750 or less	1	500	250
2,000-2,250	2	450	225
2,500	3	450	225
3,000	3	400	225
3,500-4,000	4	350	210
4,500-5,000	5	300	180
5,500	6	300	180
6,000	6	250	150
6,500-7,000	7	250	150
7,500 or more	8 or more <sup>e</sup>	200	120

For SI: One (1) foot = 304.8 mm, one (1) gallon per minute = 3.785 L/m.

<sup>a</sup> Reduce by one hundred (100) feet for dead-end streets or roads.

<sup>b</sup> Where streets are provided with median dividers which cannot be crossed by fire fighters pulling hose lines, or where arterial streets are provided with four (4) or more traffic lanes and have a traffic count of more than thirty thousand (30,000) vehicles per day, hydrant spacing shall average five hundred (500) feet on each side of the street and be arranged on an alternating basis up to a fire-flow requirement of seven thousand (7,000) gallons per minute and four hundred (400) feet for higher fire-flow requirements.

<sup>c</sup> Where new water mains are extended along streets where hydrants are not needed for protection of structures or similar fire problems, fire hydrants shall be provided at spacing not to exceed one thousand (1,000) feet to provide for transportation hazards.

ᵈ Reduce by fifty (50) feet for dead-end streets or roads.

ᵉ One (1) hydrant for each one thousand (1,000) gallons per minute or fraction thereof.

( [Ord. of 10-21-19](#) )

Appendix D. - Fire Apparatus Access Roads

Sec. D101. - General.

D101.1. *Scope.* Fire apparatus access roads shall be in accordance with this appendix and all other applicable requirements of the *International Fire Code*.

( [Ord. of 10-21-19](#) )

Sec. D102. - Required access.

D102.1. *Access and loading.* Facilities, buildings or portions of buildings hereafter constructed shall be accessible to fire department apparatus by way of an approved fire apparatus access road with an asphalt, concrete or other approved driving surface capable of supporting the imposed load of fire apparatus weighing at least seventy-five thousand (75,000) pounds (34 050 kg).

( [Ord. of 10-21-19](#) )

Sec. D103. - Minimum specifications.

D103.3. *Turning radius.* The minimum turning radius shall be determined by the fire code official.

D103.4. *Dead ends.* Dead-end fire apparatus access roads in excess of one hundred fifty (150) feet (45,720 mm) shall be provided with width and turnaround provisions in accordance with table D103.4.

TABLE D103.4 REQUIREMENTS FOR DEAD-END FIRE APPARATUS ACCESS ROADS

LENGTH (feet)	WIDTH (feet)	TURNAROUNDS REQUIRED
0-150	20	None required
151-500	20	120-foot Hammerhead, 60-foot "Y" or 96-foot-diameter cul-de-sac in accordance with figure D103.1
501-750	26	120-foot Hammerhead, 60-foot "Y" or 96-foot-diameter cul-de-sac in accordance with figure D103.1
Over 750		Special approval required

For SI: One (1) foot = 304.8 mm.

FIGURE D103.1. DEAD-END FIRE APPARATUS ACCESS ROAD TURNAROUND

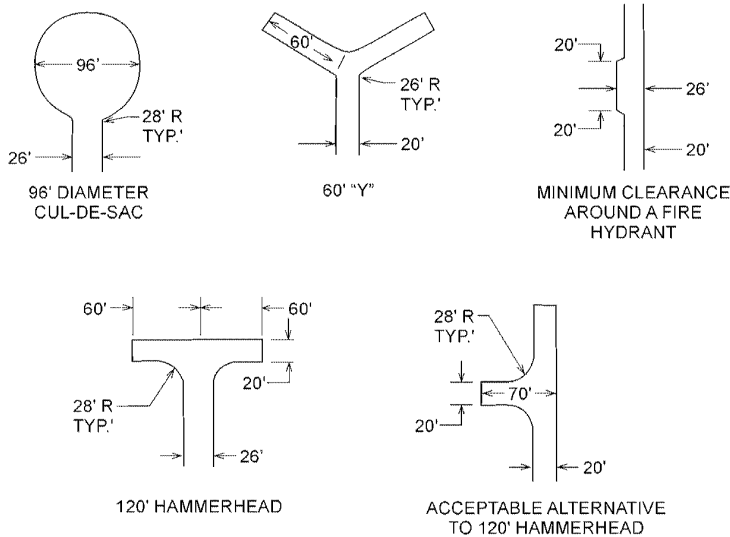

D103.5. *Fire apparatus access road gates.* Gates securing the fire apparatus access roads shall comply with all of the following criteria:

- A. The minimum gate width shall be twenty (20) feet (6096 mm).
- B. Gates shall be of the swinging or sliding type.
- C. Construction of gates shall be of materials that allow manual operation by one (1) person.
- D. Gate components shall be maintained in an operative condition at all times and replaced or repaired when defective.
- E. Electric gates shall be equipped with a means of opening the gate by fire department personnel for emergency access. Emergency opening devices shall be approved by the fire code official.
- F. Manual opening gates shall not be locked with a padlock or chain and padlock unless they are capable of being opened by means of forcible entry tools or when a key box containing the key(s) to the lock is installed at the gate location.
- G. Locking device specifications shall be submitted for approval by the fire code official.
- H. Electric gate operators, where provided, shall be listed in accordance with UL 325.
- I. Gates intended for automatic operation shall be designed, constructed and installed to comply with the requirements of ASTM F 2200.

D103.6. *Signs.* Where required by the fire code official fire apparatus fire lanes shall be marked with permanent NO PARKING—FIRE LANE marking affixed to the pavement and/or face of curbing shall meet the Brunswick County Fire Lane Marking Specification or as approved by the fire code official.

( [Ord. of 10-21-19](#) )

Sec. D104. - Commercial and industrial developments.

D104.1. Commercial and multi-family structures exceeding thirty (30) feet or three (3) stories in height shall provide at least two (2) means of fire apparatus access.

D104.2. Commercial structures having a gross enclosed floor area of over sixty-two thousand (62,000) square feet shall be provided with two (2) separate and approved fire apparatus access roads. However, when equipped throughout with an approved automatic sprinkler system, projects may be allowed to have a gross floor area of up to one hundred twenty-four thousand (124,000) square feet and provide access through one (1) approved access road.

( [Ord. of 10-21-19](#) )

Sec. D105. - Fire department aerial apparatus access roads.

Where fire department aerial apparatus access roads are required in accordance with North Carolina State Building Code: Fire Prevention Code, roads shall meet the Brunswick County aerial apparatus turning radius specification.

D105.1. *Where required.* Commercial and multi-family structures or portions of structures exceeding thirty (30) feet in height above the lowest level of fire department vehicle access shall be provided with approved fire apparatus access roads capable of accommodating fire department aerial apparatus. Overhead utility and power lines shall not be located within the aerial fire apparatus access roadway.

105.2. *Width.* Fire apparatus access roads shall have a minimum unobstructed width of twenty-six (26) feet in the immediate vicinity of any building or portion of a commercial or multi-family building more than thirty (30) feet in height.

D105.3. *Proximity to building.* At least one (1) of the required access routes shall be located at least fifteen (15) feet, but no more than thirty (30) feet from the structure and shall be parallel to one (1) entire side of the building.

( [Ord. of 10-21-19](#) )